

Sensors

Proximity, Photoelectric, and Ultrasonic Sensors, Limit Switches, Pressure Sensors, Machine Safety, Encoders, RFID, and Machine Cabling



3—OsiSense® XT

Capacitive proximity sensors

Selection guide **page 3/2**

- Overview *page 3/4*
- Metal case, cylindrical, flush mountable *page 3/8*
- Plastic case, cylindrical, non-flush mountable *page 3/12*
- Limit switch style, plastic case, plug-in *page 3/16*

OsiSense® XT

Capacitive proximity sensors

Detection of insulated or conductive materials

Applications: detection of any object irrespective of material or conductivity: for example, metals, minerals, wood, plastic, glass, cardboard, fluids.

Cylindrical sensors, flush mountable, metal case

Detection of insulated or conductive materials: for example, presence, passage of paper, cardboard, glass.



3

Form	Cylindrical	Threaded: M12 x 1	Threaded: M18 x 1	Threaded: M30 x 1.5	Plain: Ø 32
	Block, dimensions (w x h x d) in mm	-			
Case		Stainless steel	Nickel-plated brass	Nickel-plated brass	Nickel-plated brass
Sensing distance Sn, mm (in.)	Flush mountable in metal sensors	2 (0.08)	5 (0.20)	10 (0.39)	15 (0.59)
	Non-flush mountable in metal sensors	-			
Degree of protection		IP 67 IP 65 for sensors with connector			
Supply	---	•	•	•	-
	~	-	•	•	•
Connection	Pre-cabled	•			
	Connector	•	•	•	-
	Screw terminals	-			
Catalog Number		XT112S1●	XT118B1●	XT130B1●	XT132B1●
Pages		8			

OsiSense® XT

Capacitive proximity sensors

Detection of insulated or conductive materials

Cylindrical sensors, non-flush mountable, plastic case	Block type sensors, flush mountable in a support, plastic case
Detection of insulated or conductive materials Liquid level control	Detection of insulated materials: for example, presence, passage of paper, cardboard, glass.



3

Threaded: M18 x 1	Threaded: M30 x 1.5	Plain: Ø 32	–
–	–	–	40 x 117 x 41
Plastic	–	–	Plastic, turret head
–	–	–	15 (0.59)
8 (0.31)	15 (0.59)	20 (0.79)	–
IP 67, double insulation	–	–	IP 67
•	•	–	•
•	–	–	•
•	–	–	–
•	•	–	–
–	–	–	•
XT218A1●	XT230A1●	XT232A1●	XT7C40●
12	–	–	16

OsiSense® XT Capacitive proximity sensors

Detection of insulated or conductive materials

Presentation

3

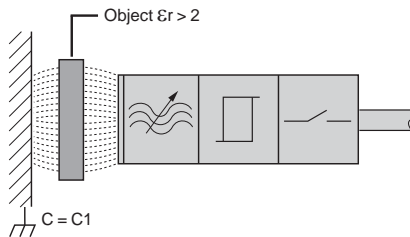
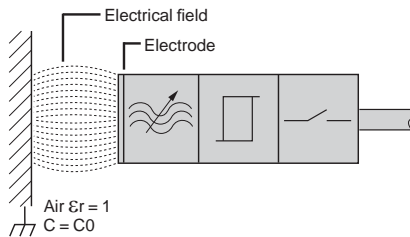

Types of sensor

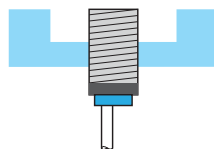
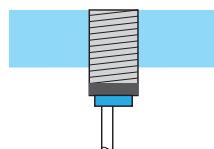
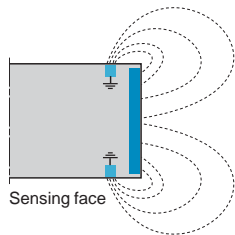
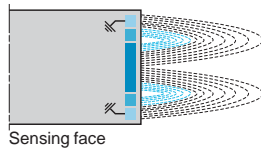

Advantages

- No physical contact with the object to be detected.
- High operating rates.
- Solid-state product, no moving parts (service life not related to number of operating cycles).
- Detection of any object, irrespective of material or conductivity: for example, metals, minerals, wood, plastic, glass, cardboard, leather, ceramic, fluids.

Operating principle

An electrical field is created between 2 electrodes on the front face of the sensor. These electrodes constitute a capacitor with a capacitance of:
 $C = \epsilon_0 * \epsilon_r * A/d$ where:
 $\epsilon_0 = 8.854187 \text{ pF/m}$ (permittivity [dielectric constant] in free space)
 ϵ_r : relative permittivity (dielectric constant) of the material present between the two electrodes
 A: dimensions of electrodes
 d: distance between electrodes

All materials where $\epsilon_r > 2$ will be detected.

When an object of any material ($\epsilon_r > 2$) passes the sensing face of the sensor, it modifies the coupling capacitance (C_1). This variation in capacitance ($C_1 > C_0$) starts the oscillator, which in turn causes the output driver to operate and provides an output signal.

Sensors, flush mountable in a support

The special feature of these versions is the shape of the electrical field, which is rectilinear and confined within the dimensions of the product. Cylindrical and block type models are used for the detection of insulated materials (wood, plastic, cardboard, glass), conductive materials (metal), or liquid through an insulated partition (glass, plastic) with a maximum thickness of 4 mm (0.16 in.).

These products are recommended for:

- comparatively short detection distances,
- applications requiring flush mounting of the sensor,
- detection through a partition (example: detection of glass through cardboard),
- side by side mounting.

Sensors, non-flush mountable in a support

Cylindrical models (plastic case).

The spherical shape of the electrical field permits the detection of any type of material whether it be solid, liquid, or granular (metal, water, oil, plastic pellets, powder, flour). Detection can be achieved through a partition or by direct contact (immersion) of the active surface with the object to be detected.

For clearances around the sensing face, see page 11.

Mounting precautions

Non-flush mountable models cannot be flush mounted in their support. The non-flush mountable models require a free zone around the active head. (See page 11).

OsiSense® XT

Capacitive proximity sensors

Detection of insulated or conductive materials

Terminology

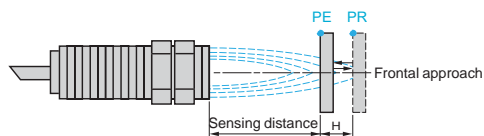
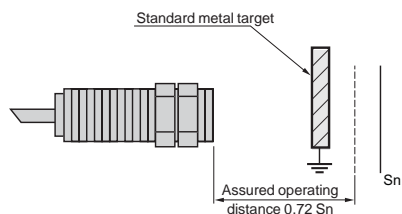
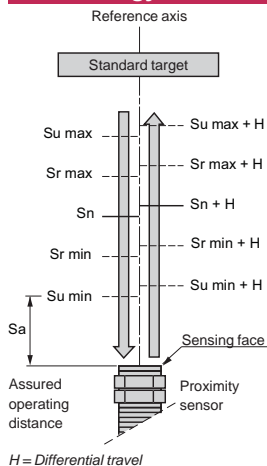

PE = pick-up point: the target is detected
PR = drop-out point: the target is no longer detected

Definitions

To ensure that customers can make reliable product comparisons and selection, the IEC 60947-5-2 standard defines various sensing distances, such as:

Nominal sensing distance (S_n)

The rated operating distance for which the sensor is designed. It does not take into account any variations such as manufacturing tolerances, temperature, voltage).

Effective sensing distance (S_r)

The effective sensing distance is measured at the rated voltage (U_n) and the rated ambient temperature ($23 \pm 5 \text{ }^\circ\text{C}$ [$73.40 \pm 9 \text{ }^\circ\text{F}$]). The range must be between 90% and 110% of S_n .

Usable sensing distance (S_u)

The usable sensing distance is measured at the limits of the permissible variations in the ambient temperature, and at a supply voltage equal to 85% and 110% of the rated voltage.

The range must be between 80% and 120% of S_r .

Assured operating distance (S_a)

This is the operating zone of the sensor.

The assured operating distance range is between 0 and 72% of S_n .

Standard metal target

The IEC 60947-5-2 standard defines the standard metal target as a square mild steel plate (Fe 360), 1 mm (0.04 in.) thick.

The side dimension of the plate is equal to either the diameter of the circle engraved on the sensing face of the sensor or three times the nominal sensing distance (S_n).

Repeat accuracy

The repeat accuracy (R) is the repeatability of the sensing distance between successive operations. Readings are taken over a period of time while the sensor is subjected to voltage and temperature variations: 8 hours, 10 to $30 \text{ }^\circ\text{C}$ (50 to $86 \text{ }^\circ\text{F}$), $U_n \pm 5\%$.

Repeat accuracy is expressed as a percentage of the effective sensing distance, S_r .

Differential travel

The differential travel (H), or hysteresis, is the distance between the pick-up point, as the standard metal target moves towards the sensor, and the drop-out point, as it moves away.

This hysteresis is essential for the stable operation of the sensor.

OsiSense® XT Capacitive proximity sensors

Detection of insulated or conductive materials

Terminology (continued)

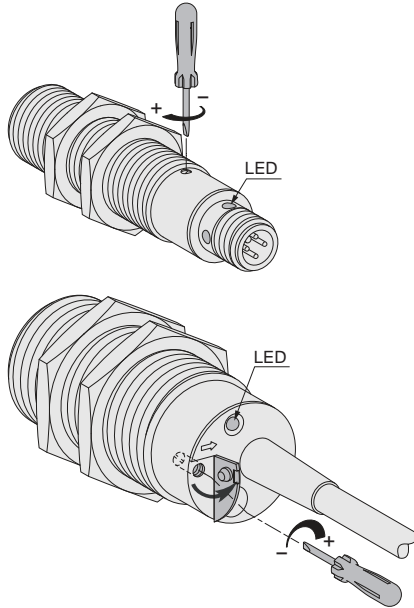

3

Sensitivity of the sensor

All Schneider Electric capacitive sensors incorporate a sensitivity adjustment potentiometer. This allows you to adjust the sensitivity of the sensor to suit the type of object to be detected.

Depending on the sensor version, the sensitivity adjustment potentiometer is mounted on either the side or the rear.

The sensors are factory preset for nominal sensitivity.

Depending on the application, you may need to adjust the sensitivity as follows:

- increase the sensitivity for objects which have a weak influence (low ϵ_r): paper, cardboard, glass, plastic,
- decrease the sensitivity for objects which have a strong influence (strong ϵ_r): metals, liquids.

However, where severe variations in the ambient conditions occur, do not increase the sensitivity of the sensor to its maximum operating limits.

An increase in sensitivity causes an increase in the switching hysteresis.

Operating distances

The operating distance of the sensor is related to the dielectric constant (ϵ_r) of the object material to be detected.

The higher the value of ϵ_r , the easier it is to detect the object.

The assured operating distance depends on the object material: $St = Sn \times Fc$

St = assured operating distance,

Sn = nominal sensing distance of the sensor,

Fc = correction factor related to the object material.

Example: sensor XT130B1PAL2 is used to detect a rubber object.

$Sn = 10 \text{ mm (0.39 in.)}$, $Fc = 0.3$.

Assured operating distance $St = 10 \times 0.3 \text{ mm (0.39} \times 0.31 \text{ in.)}$.

The list below indicates the dielectric constant values of the most common object materials, along with their correction factors (Fc) for the nominal sensing distance of the sensor.

Material	ϵ_r	Fc	Material	ϵ_r	Fc
Air	1	0	Gasoline	2.2	0.2
Acetone	20	0.8	Plexiglass	3.2	0.3
Alcohol	24	0.85	Polyester resin	2.8–8	0.2–0.6
Ammonia	15–25	0.75–0.85	Polystyrene	3	0.3
Cement (powder)	4	0.35	Porcelain	5–7	0.4–0.5
Cereals	3–5	0.3–0.4	Powdered milk	3.5–4	0.3–0.4
Epoxy resin	4	0.36	Rubber	2.5–3	0.3
Ethylene glycol	38	0.95	Salt	6	0.5
Flour	2.5–3	0.2–0.3	Sand	3–5	0.3–0.4
Glass	3–10	0.3–0.7	Sugar	3	0.3
Marble	6–7	0.5–0.6	Teflon	2	0.2
Mica	6–7	0.5–0.6	Petroleum jelly	2–3	0.2–0.3
Nylon	4–5	0.3–0.4	Water	80	1
Oil	2.2	0.2	Wood (damp)	10–30	0.7–0.9
Paper	2–4	0.2–0.3	Wood (dry)	2–7	0.2–0.6
Paraffin	2–2.5	0.2			

OsiSense® XT Capacitive proximity sensors

Detection of insulated or conductive materials

Environment

■ Electromagnetic interference

The sensors undergo electromagnetic interference testing in accordance with the recommendations of the IEC 60947-5-2 standard (electrostatic discharges, radiated electromagnetic fields, fast transients, impulse voltages).

■ Thermal influences

To avoid sensing distance drift and possible incorrect operation of the sensor, observe the values stated on the specification pages.

■ Chemical agents

To ensure a long service life, it is essential that any chemicals coming into contact with the case of the sensor are non-corrosive.

■ Grounding

Grounding an object that has a high conductivity increases the sensing distance.

Additional information relating to outputs

Refer to the corresponding pages relating to inductive proximity sensors for:

- Terminology
- Details and specific aspects of 2-wire and 3-wire type connections
- Connecting several sensors in series or parallel

3

Application example: Bottle filling

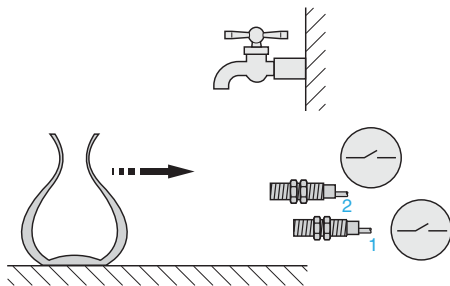

■ Bottle arrival

Bottles are fed on a conveyor for filling.

Sensors 1 and 2 are in an unoperated state.

Adjustment:

- sensor 1 is adjusted to detect the bottle
- sensor 2 is adjusted to detect the water in the bottle

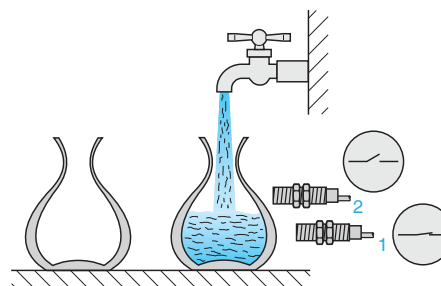

■ Bottle filling

As soon as the bottle enters the detection zone of sensor 1, the filling operation commences.

Sensor 2 remains in the unoperated state.

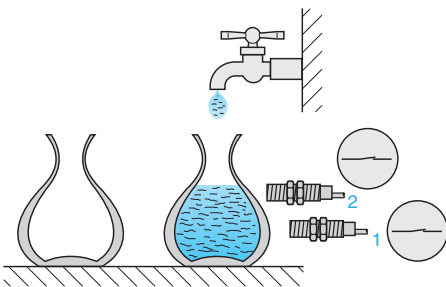

■ Filling complete

Sensor 2 detects that the required level has been reached and stops further filling.

Reminder: the wall of the container must be non-metallic and its thickness ≤ 4 mm (0.16 in.)

OsiSense® XT Capacitive proximity sensors

Cylindrical, flush mountable, metal case
AC or DC supply

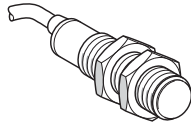

XT112S1●●L2

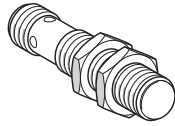

XT112S1PCM12

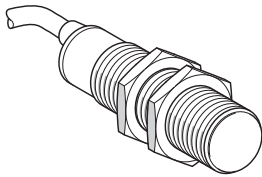

XT118B1●●L2

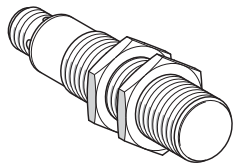

XT118B1PCM12

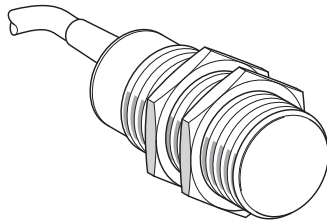

XT130B1●●L2

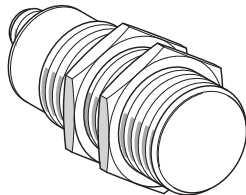

XT130B1PCM12

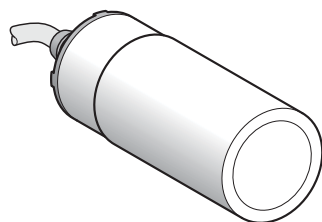

XT132B1F●L2

Ø 12, threaded M12 x 1, stainless steel

Sensing distance Sn, mm (in.)	Function	Output	Connection	Catalog Number	Weight kg (lb)
Four-wire --- 24 V					
2 (0.08)	NO/NC	PNP	Pre-cabled	XT112S1PCL2	0.070 (0.15)
			M12 connector	XT112S1PCM12	0.040 (0.09)

Three-wire --- 24 V					
2 (0.08)	NO	PNP	Pre-cabled	XT112S1PAL2	0.070 (0.15)
			NPN	Pre-cabled	XT112S1NAL2

Ø 18, threaded M18 x 1, nickel-plated brass

Sensing distance Sn, mm (in.)	Function	Output	Connection	Catalog Number	Weight kg (lb)
Four-wire --- 24 V					
5 (0.20)	NO/NC	PNP	Pre-cabled	XT118B1PCL2	0.150 (0.33)
			M12 connector	XT118B1PCM12	0.075 (0.17)

Three-wire --- 24 V					
5 (0.20)	NO	PNP	Pre-cabled	XT118B1PAL2	0.150 (0.33)
			NPN	Pre-cabled	XT118B1NAL2

Two-wire ~ 24-240 V					
5 (0.20)	NO	-	Pre-cabled	XT118B1FAL2	0.150 (0.33)
			NC	Pre-cabled	XT118B1FBL2

Ø 30, threaded M30 x 1.5, nickel-plated brass

Sensing distance Sn, mm (in.)	Function	Output	Connection	Catalog Number	Weight kg (lb)
Four-wire --- 24 V					
10 (0.39)	NO/NC	PNP	Pre-cabled	XT130B1PCL2	0.270 (0.60)
			M12 connector	XT130B1PCM12	0.150 (0.33)

Three-wire --- 24 V					
10 (0.39)	NO	PNP	Pre-cabled	XT130B1PAL2	0.270 (0.60)
			NPN	Pre-cabled	XT130B1NAL2

Two-wire ~ 24-240 V					
10 (0.39)	NO	-	Pre-cabled	XT130B1FAL2	0.270 (0.60)
			NC	Pre-cabled	XT130B1FBL2

Ø 32, plain, nickel-plated brass (1)

Sensing distance Sn, mm (in.)	Function	Output	Connection	Catalog Number	Weight kg (lb)
Two-wire ~ 24-240 V					
15 (0.59)	NO		Pre-cabled	XT132B1FAL2	0.400 (0.88)
			NC	Pre-cabled	XT132B1FBL2

(1) Mounting accessory included with sensor.

Accessories

For mounting and protection accessories, fuses, and fuse terminal block, see page 11.

OsiSense® XT

Capacitive proximity sensors

Cylindrical, flush mountable, metal case
AC or DC supply

Specifications							
Sensor type		M12 XT112●	M18 XT118●	M30 XT130●	Ø 32 XT132●		
		3-wire ⎓ 4-wire ⎓	3-wire ⎓ 4-wire ⎓	2-wire ~	3-wire ⎓ 4-wire ⎓	2-wire ~	2-wire ~
Product certifications		CE, c ETL us					
Conformity to standards		IEC 60947-5-2					
Connection		Pre-cabled, length 2 m					
		Connector, M12					
		●	●	●	●	●	●
		●	●	–	●	–	–
Main specifications							
Nominal sensing distance Sn	Conforming to IEC 60947-5-2	mm	2 (0.08 in.)	5 (0.20 in.)	10 (0.39 in.)	15 (0.59 in.)	
Assured operating distance Sa	Conforming to IEC 60947-5-2	mm	0–1.44 (0–0.06 in.)	0–3.60 (0–0.14 in.)	0–3.60 (0–0.14 in.)	0–7.2 (0–0.28 in.)	0–7.2 (0–0.28 in.)
Adjustment zone		mm	0.5–5 (0.02– 0.20 in.)	1–8 (0.04– 0.31 in.)	1–5 (0.04– 0.20 in.)	2–20 (0.08– 0.79 in.)	2–15 (0.08– 0.59 in.)
Repeat accuracy			< 0.1 Sr				< 0.15 Sr
Differential travel			< 0.2 Sr				< 0.2 Sr
Output specifications							
Output state indication		Yellow LED					
Switching capacity		mA	200	200	330	200	330
Maximum switching frequency		Hz	300	200	25	150	25
Protection against short-circuits			●	●	– (1)	●	– (1)
Voltage drop		V	≤ 2	≤ 2	≤ 6	≤ 2	≤ 6
Residual current, open state		mA	< 0.1	< 0.1	< 5	< 0.1	< 5
Delays							
		First-up	ms	≤ 30	≤ 30	≤ 100	≤ 30
		Response	ms	≤ 5	≤ 5	≤ 20	≤ 5
		Recovery	ms	≤ 5	≤ 5	≤ 20	≤ 5
Supply							
Rated supply voltage		V	⎓ 24	⎓ 24	~ 24–240 50/60 Hz	⎓ 24	~ 24–240 50/60 Hz
Voltage limits (including ripple)		V	⎓ 12–30	⎓ 12–30	~ 20–264 50/60 Hz	⎓ 12–30	~ 20–264 50/60 Hz
Current consumption, no-load		mA	< 15	< 15	< 3	< 15	< 3
Protection against reverse polarity			Yes	Yes	–	Yes	–
Environment							
Materials							
		Case	Stainless steel 303	Nickel-plated brass			
		Cable	PVC				
		Number and c.s.a. of wires	3 x 0.14 mm ² (26 AWG) or 4 x 0.14 mm ² (26 AWG)	3 x 0.34 mm ² (22 AWG) or 4 x 0.34 mm ² (22 AWG)	3 x 0.34 mm ² (22 AWG)	3 x 0.75 mm ² (18 AWG) or 4 x 0.5 mm ² (20 AWG)	3 x 0.75 mm ² (18 AWG)
							3 x 0.34 mm ² (22 AWG)
Degree of protection		Conforming to IEC 60529 and IEC 60947-5-2	IP 67 (2) IP 65 for sensors XT112S1PCM12 and XT118B1PCM12				IP 67
Storage and operating temperature		°C	-25 to +70 (-13 to +158 °F)				
Vibration resistance		Conforming to IEC 60068-2-6	10 gn, ± 1 mm				
Shock resistance		Conforming to IEC 60068-2-27	30 gn, 11 ms				30 gn, 6 ms
Resistance to electromagnetic interference							
Electrostatic discharges		Conforming to IEC 61000-4-2	kV				
			8 (air) / 4 (contact)				
Radiated electromagnetic fields		Conforming to IEC 61000-4-3	V/m				
			3				
Fast transients		Conforming to IEC 61000-4-4	kV				
			2				

(1) These sensors do not incorporate overload or short-circuit protection. A fast-acting fuse must be connected in series with the load (see page 11).
(2) With adjustment potentiometer sealing screw.



OsiSense® XT Capacitive proximity sensors

Cylindrical, flush mountable, metal case
AC or DC supply

Dimensions (mm)

M12, pre-cabled
XT112S1●●L2

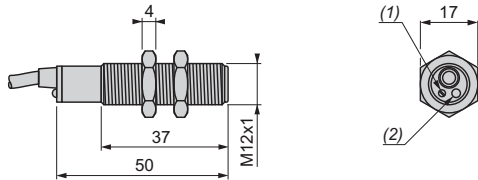

M12, M12 connector
XT112S1PCM12

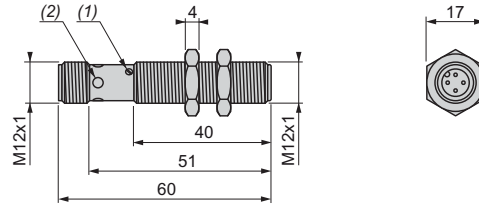

M18, pre-cabled
XT118B1●●L2

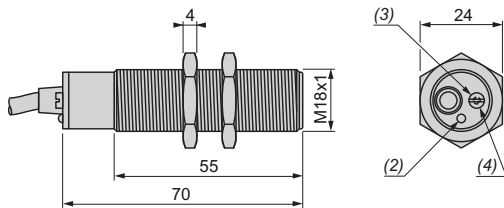

M18, M12 connector
XT118B1PCM12

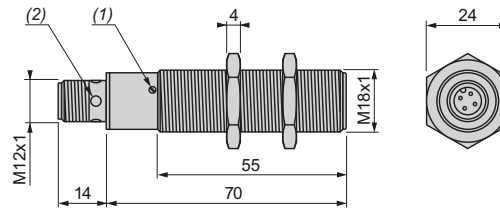

M30, pre-cabled
XT130B1●●L2

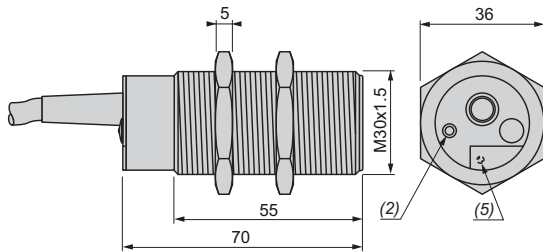

M30, M12 connector
XT130B1PCM12

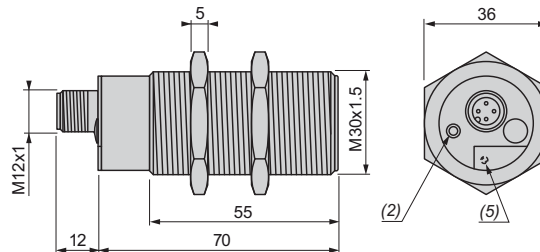

Ø 32, plain, pre-cabled
XT132B1F●L2

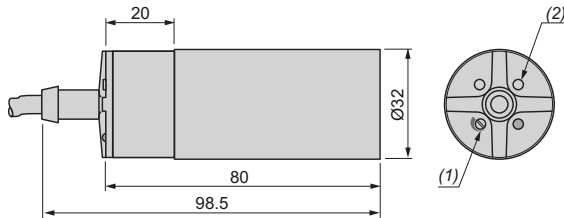

Mounting accessory (included with sensor XT132B1F●L2)

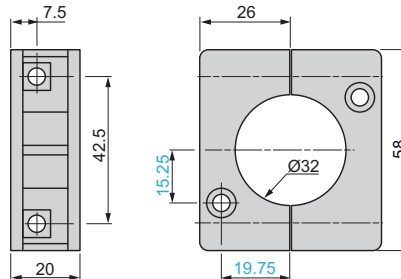

- (1) Adjustment potentiometer
- (2) LED
- (3) Sealing screw
- (4) Potentiometer beneath sealing screw
- (5) Potentiometer beneath protective flap

Wiring diagrams

Connector version

M12 connector



4-wire ~, PNP
NO + NC output, M12

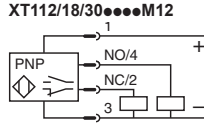

Pre-cabled version

Cable

4-wire ~, PNP
NO + NC output,
pre-cabled

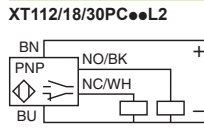

3-wire ~, PNP
NO output, pre-cabled

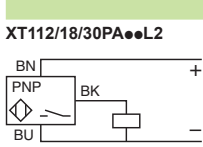

3-wire ~, NPN
NO output, pre-cabled

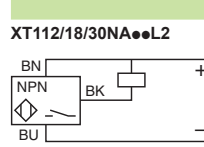

BU: Blue
BN: Brown
BK: Black
WH: White
YE/GN: Yellow/green

2-wire ~
NO output

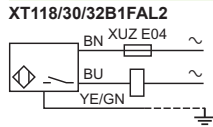

2-wire ~
NC output

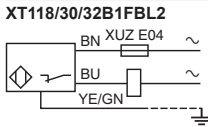

3

Adjustment

Sensitivity adjustment

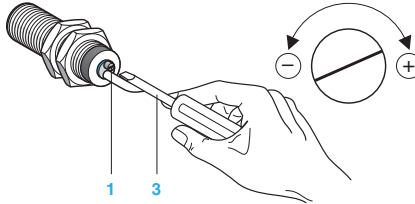
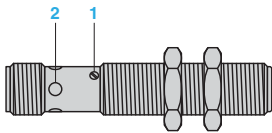

- 1 Adjustment potentiometer
- 2 LED
- 3 Adjustment using suitable screwdriver (included with sensor)

Adjustment from the side for	XT112●●●●M12 XT118●●●●M12
Adjustment from the rear for	XT1●●●●L2 XT130●●●●M12

Setup

Minimum mounting distances (mm)

Side by side

Face to face

Facing a metal object

Mounted in a support

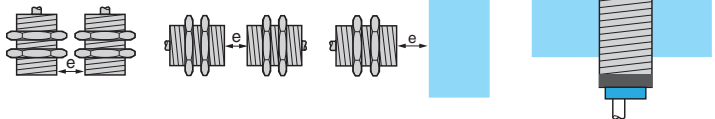

XT1 M12 flush mountable	$e \geq 0$	$e \geq 2.2 \times S_n$	$e \geq 2 \times S_n$	–
XT1 M18 flush mountable	$e \geq 0$	$e \geq 2.2 \times S_n$	$e \geq 2 \times S_n$	–
XT1 M30 flush mountable	$e \geq 0$	$e \geq 2.2 \times S_n$	$e \geq 2 \times S_n$	–

Mounting nut tightening torque: XT112: 10 N•m (88.50 lb-in), XT118: 28 N•m (247.80 lb-in), XT130: 40 N•m (354.00 lb-in)

OsiSense® XT

Capacitive proximity sensors

Cylindrical, non-flush mountable, plastic case
AC or DC supply

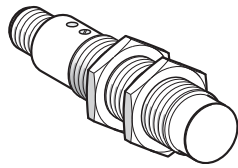

XT218A1PCM12

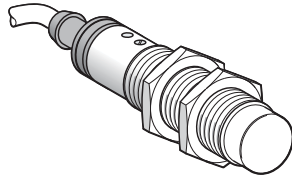

XT218A1●AL2

3

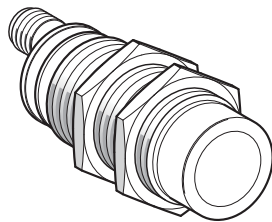

XT230A1PCM12

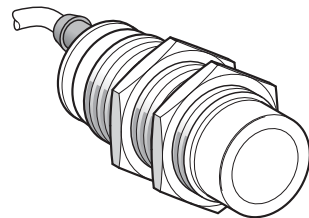

XT230A1●●L2

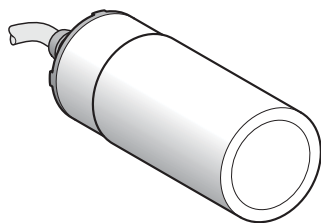

XT●32●1F●L2



XUZA118

Ø 18, threaded M18 x 1

Sensing distance Sn, mm (in.)	Function	Output	Connection	Catalog Number	Weight kg (lb)
----------------------------------	----------	--------	------------	----------------	-------------------

Four-wire ≡ 12–24 V

8 (0.31)	NO/NC	PNP	M12 connector	XT218A1PCM12	0.060 (0.13)
----------	-------	-----	---------------	--------------	--------------

Three-wire ≡ 12–24 V

8 (0.31)	NO	PNP	Pre-cabled	XT218A1PAL2	0.140 (0.31)
		NPN	Pre-cabled	XT218A1NAL2	0.140 (0.31)

Two-wire ~ 24–240 V

8 (0.31)	NO	–	Pre-cabled	XT218A1FAL2	0.140 (0.31)
----------	----	---	------------	-------------	--------------

Ø 30, threaded M30 x 1.5

Sensing distance Sn, mm (in.)	Function	Output	Connection	Catalog Number	Weight kg (lb)
----------------------------------	----------	--------	------------	----------------	-------------------

Four-wire ≡ 12–24 V

15 (0.59)	NO/NC	PNP	M12 connector	XT230A1PCM12	0.100 (0.22)
-----------	-------	-----	---------------	--------------	--------------

Three-wire ≡ 12–24 V

15 (0.59)	NO	PNP	Pre-cabled	XT230A1PAL2	0.200 (0.44)
		NPN	Pre-cabled	XT230A1NAL2	0.200 (0.44)

Two-wire ~ 24–240 V

15 (0.59)	NO	–	Pre-cabled	XT230A1FAL2	0.200 (0.44)
	NC	–	Pre-cabled	XT230A1FBL2	0.200 (0.44)

Ø 32, plain (1)

Sensing distance Sn, mm (in.)	Function	Output	Connection	Catalog Number	Weight kg (lb)
----------------------------------	----------	--------	------------	----------------	-------------------

Two-wire ~ 24–240 V

20 (0.79)	NO	–	Pre-cabled	XT232A1FAL2	0.350 (0.77)
	NC	–	Pre-cabled	XT232A1FBL2	0.350 (0.77)

(1) Mounting accessory included with the sensor.

Accessories for capacitive sensors XT1● and XT2●

Mounting accessories

Description	For use with sensor	Catalog Number	Weight kg (lb)
90° Mounting bracket	Ø 12	XXZ12	0.025 (0.06)
	Ø 18	XUZA118	0.045 (0.10)
	Ø 30	XXZ30	0.115 (0.25)

Protection accessories

Description	For use with sensor	Catalog Number	Weight kg (lb)
Threaded sleeve	Ø 30, threaded M30 x 1.5	XTAZ30	0.035 (0.08)
	Ø 32, threaded M32 x 1.5	XTAZ32	0.035 (0.08)

Fuses (for unprotected 2-wire ~ sensors)

Description	Type	Sold in lots of	Catalog Number	Weight kg (lb)
Cartridge fuses 5 x 20	0.4 A fast-acting	10	XUZE04	0.001 (0.001)
	0.63 A fast-acting	10	XUZE06	0.001 (0.001)
	0.8 A fast-acting	10	XUZE08	0.001 (0.001)

Fuse terminal block

Description	Sold in lots of	Catalog Number	Weight kg (lb)
Fuse terminal block for 5 x 20 fuses, gray	50	AB1FUSE435U5X	0.016 (0.04)

OsiSense® XT

Capacitive proximity sensors

Cylindrical, non-flush mountable, plastic case
AC or DC supply

Specifications								
Sensor type		M18			M30			Ø 32
		XT218			XT230			XT232
		4-wire ---	3-wire ---	2-wire ~	4-wire ---	3-wire ---	2-wire ~	2-wire ~
Product certifications		CE						
Conformity to standards		IEC 60947-5-2						
Connection		Pre-cabled, 2 m Connector, M12						
		-	•	•	-	•	•	•
		•	-	-	•	-	-	-
Main specifications								
Nominal sensing distance Sn	Conforming to IEC 60947-5-2	mm	8 (0.31 in.)			15 (0.59 in.)		20 (0.79 in.)
Assured operating distance Sa	Conforming to IEC 60947-5-2	mm	0–5.8 (0–0.23 in.)			0–11 (0–0.43 in.)		0–15 (0–0.59 in.)
Adjustment zone		mm	0–12 (0–0.47 in.)			0–17 (0–0.67 in.)		0–22 (0–0.87 in.)
Repeat accuracy			< 5% Sr					
Differential travel			< 1–20% Sr					
Output specifications								
Output state indication			Yellow LED					
Switching capacity		mA	2 x 200	200	300	2 x 200	200	300
Maximum switching frequency		Hz	30	30	15	50	50	15
Protection against short-circuits			•	•	– (1)	•	•	– (1)
Voltage drop, closed state		V	< 2.5	< 2.5	< 10	< 2.5	< 2.5	< 10
Residual current, open state		µA	≤ 100	≤ 100	–	≤ 100	≤ 100	–
Delays	First-up	ms	< 100	< 100	< 200	< 100	< 100	< 200
	Response	ms	< 15	< 15	< 30	< 15	< 10	< 30
	Recovery	ms	< 15	< 15	< 30	< 15	< 10	< 30
Supply								
Rated supply voltage		V	--- 12–24		~ 24–240 50/60 Hz	--- 12–24		~ 24–240 50/60 Hz
Voltage limits (including ripple)		V	--- 10–30		~ 20–265	--- 10–30		~ 20–265
Current consumption, no-load	24 V	mA	< 25	< 15	–	< 25	< 15	–
	240 V	mA	–	–	< 4	–	–	< 4
Protection against reverse polarity			Yes	Yes	–	Yes	Yes	–
Environment								
Materials		Case	Plastic					
		Cable	PVC					
		Number and c.s.a. of wires	–	3 x 0.34 mm ² (22 AWG)	2 x 0.5 mm ² (22 AWG)	–	3 x 0.34 mm ² (22 AWG)	2 x 0.5 mm ² (22 AWG)
								2 x 0.5 mm ² (20 AWG)
Degree of protection		Conforming to IEC 60529	IP 67, double insulation \square					
Storage and operating temperature		°C	-10 to +60 (-14 to +140 °F)					
Vibration resistance		Conforming to IEC 60068-2-6	10 gn, ± 1 mm					
Shock resistance		Conforming to IEC 60068-2-27	30 gn, 1/2 sine wave, 6 ms					
Resistance to electromagnetic interference								
Electrostatic discharges		Conforming to IEC 61000-4-2	kV 8 (air) / 4 (contact)					
Radiated electromagnetic fields		Conforming to IEC 61000-4-3	V/m 3					
Fast transients		Conforming to IEC 61000-4-4	kV 2					

(1) These sensors do not incorporate overload or short-circuit protection. A fast-acting fuse must be connected in series with the load.

3

OsiSense® XT

Capacitive proximity sensors

Cylindrical, non-flush mountable, plastic case
AC or DC supply

Dimensions (mm)

M18, pre-cabled
XT218A1●●L2

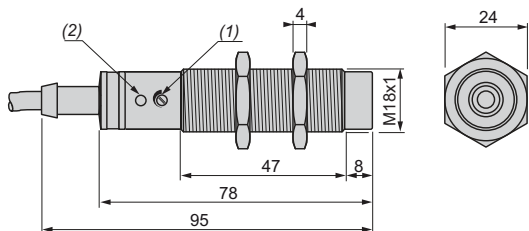

(1) Adjustment potentiometer
(2) LED

M18, M12 connector
XT218A1PCM12

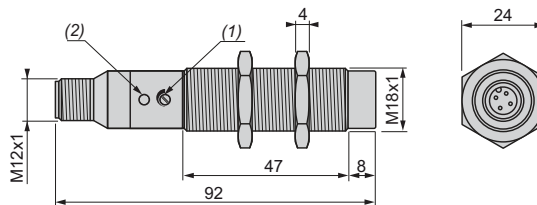

(1) Adjustment potentiometer
(2) LED

M30, pre-cabled
XT230A1●●L2

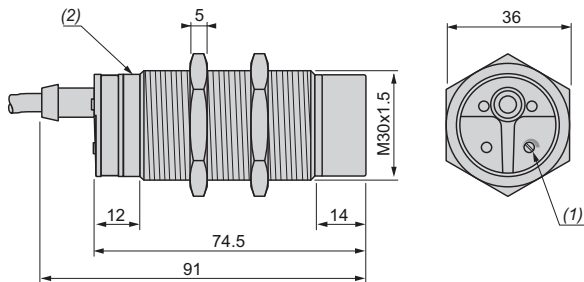

(1) Adjustment potentiometer
(2) LED

M30, M12 connector
XT230A1PCM12

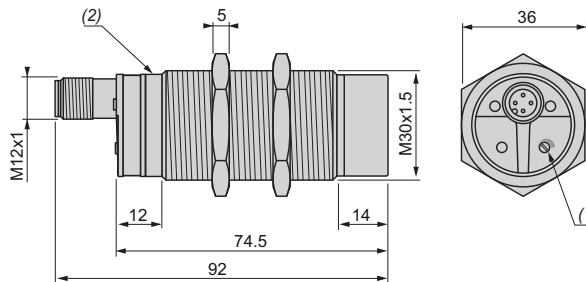

(1) Adjustment potentiometer
(2) LED

Ø 32, plain, pre-cabled
XT232A1F●L2

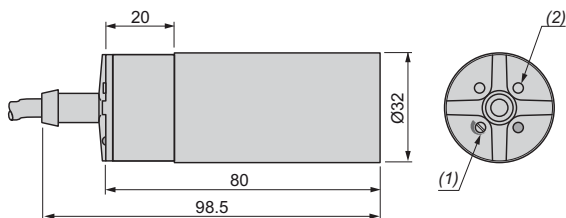

(1) Adjustment potentiometer
(2) LED

Mounting accessory (included with sensor XT232A1F●L2)

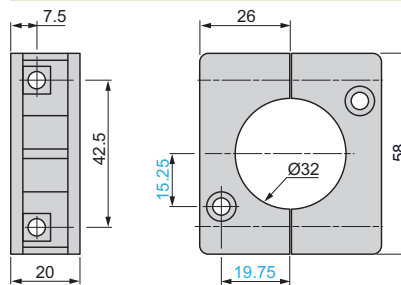

Accessories

XUZA118

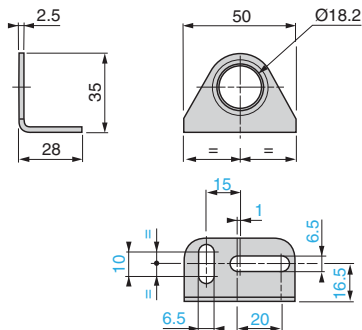

XXZ12, XXZ30

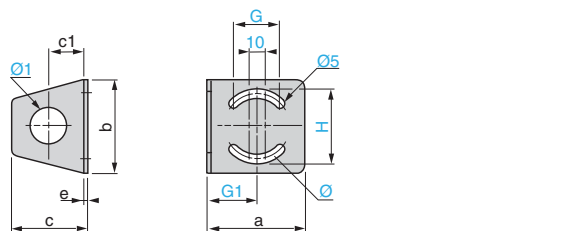

XXZ	a	b	c	c1	e	H	G	G1	Ø	Ø1
12	35	40	33	18	2	31	18	18	25	13
30	67	65	52	25	3	51	35	33	50	31

Dimensions, Wiring Diagrams, Adjustment, Setup

OsiSense® XT Capacitive proximity sensors

Cylindrical, non-flush mountable, plastic case
AC or DC supply

Dimensions (mm) (continued)

XTAZ30

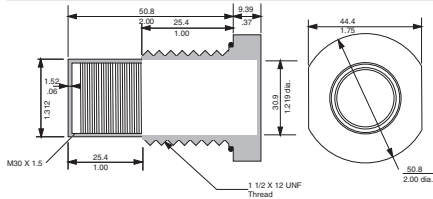

XTAZ32

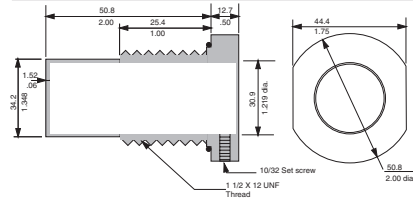

Wiring diagrams

Connector version

M12 connector

4-wire \sim , PNP
NO + NC output, M12

XT218/30●●●●M12

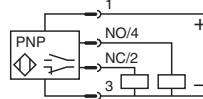

3

Pre-cabled version

Cable

3-wire \sim , PNP
NO output

XT218/30A1PAL2

3-wire \sim , NPN
NO output

XT218/30A1NAL2

2-wire \sim
NO output

XT218/30/32A1FAL2

2-wire \sim
NC output

XT230/32A1FBL2

BU: Blue
BN: Brown
BK: Black
WH: White

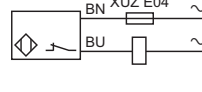
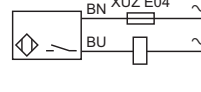
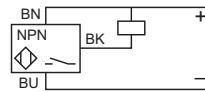
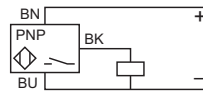

Adjustment

Sensitivity adjustment

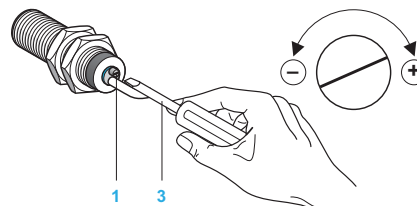
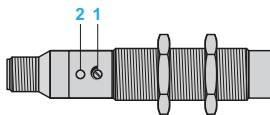

- 1 Adjustment potentiometer
- 2 LED
- 3 Adjustment using suitable screwdriver (included with sensor)

Adjustment from the side for **XT218A1**

Adjustment from the rear for **XT230A1**

XT232A1

Setup

Minimum mounting distances (mm)

Side by side

Face to face

Facing a metal object

Mounted in support

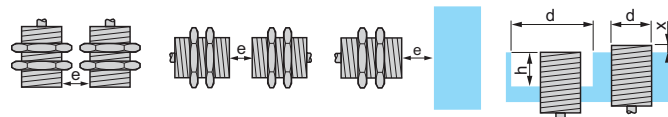

	Side by side	Face to face	Facing a metal object	Mounted in support
XT2 M18 non-flush mountable	$e \geq 40$	$e \geq 6 \text{ Sn}$	$e \geq 3 \text{ Sn}$	$d \geq 60$ $h \geq 20$
XT2 M30 non-flush mountable	$e \geq 60$	$e \geq 6 \text{ Sn}$	$e \geq 3 \text{ Sn}$	$d \geq 90$ $h \geq 30$
XT2 Ø 32 non-flush mountable	$e \geq 65$	$e \geq 6 \text{ Sn}$	$e \geq 3 \text{ Sn}$	$d \geq 100$ $h \geq 30$

Mounting nut tightening torque: **XT218**: 3 N•m (26.6 lb-in), **XT230**: 8 N•m (70.80 lb-in)

OsiSense® XT Capacitive proximity sensors

For detection of insulated materials
Limit-switch style
Plastic case, plug-in, turret head
AC or DC supply

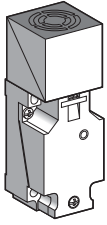

XT7C40●●C440H7

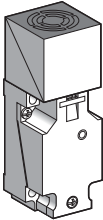

XT7C40●●●262H7

Sensors, flush mountable in a support

3-wire ~ 12–48 V flush mountable

Sensing distance Sn, mm (in.)	Function	Output	Catalog Number	Weight kg (lb)
15 (0.59)	NO + NC	PNP	XT7C40PC440H7	0.220 (0.49)
		NPN	XT7C40NC440H7	0.220 (0.49)

2-wire ~ 24–240 V (50/60 Hz) flush mountable

Sensing distance Sn, mm (in.)	Function	Catalog Number	Weight kg (lb)
15 (0.59)	NO or NC via programming	XT7C40FP262H7	0.220 (0.49)

Accessories

Fuses (for unprotected 2-wire ~ sensors)

Description	Type	Sold in lots of	Catalog Number	Weight kg (lb)
Cartridge fuses 5 x 20	0.4 A fast-acting	10	XUZE04	0.001 (0.001)
	0.63 A fast-acting	10	XUZE06	0.001 (0.001)
	0.8 A fast-acting	10	XUZE08	0.001 (0.001)

Fuse terminal block

Description	Sold in lots of	Catalog Number	Weight kg (lb)
Fuse terminal block for 5 x 20 fuses, gray	50	AB1FUSE435U5X	0.016 (0.04)

Dimensions (mm)

XT7C40●●●●●

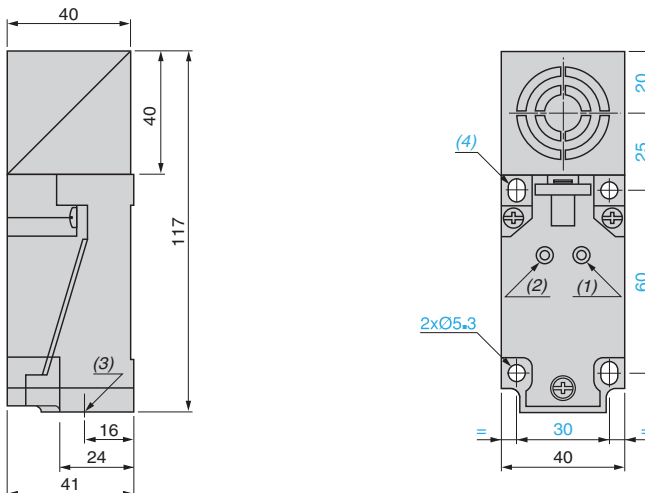

- (1) Output LED
- (2) Supply LED (depending on model)
- (3) 1 tapped entry for Pg 13 cable gland
- (4) 2 elongated holes \varnothing 5.3 x 7

OsiSense® XT Capacitive proximity sensors

For detection of insulated materials
Limit-switch style
Plastic case, plug-in, turret head
AC or DC supply

Specifications			
Sensor type		XT7C40●C440H7	XT7C40FP262H7
Connection		Screw terminals, clamping capacity 4 x 1.5 mm ² (4 x 16 AWG) (1)	Screw terminals, clamping capacity 3 x 1.5 mm ² (3 x 16 AWG) (1)
Degree of protection	Conforming to IEC 60529	IP 67	
Operating zone	mm	0–10.8 (0–0.43 in.)	
Repeat accuracy		≤ 0.1 Sr	
Product certifications		UL, CSA, CE	
Differential travel		≤ 0.2 Sr	
Operating temperature	°C	-25 to +70 (-13 to +158 °F)	
Output state indication		Yellow LED: output Green LED: supply	Yellow LED: output
Rated supply voltage	V	⋯ 12–48	~ 24–240 (50/60 Hz)
Voltage limits (including ripple)	V	⋯ 10–58	~ 20–264
Switching capacity	mA	0–200 with overload and short-circuit protection	5–350 (2 A inrush) (2)
Voltage drop, closed state	V	≤ 2	≤ 5.5
Residual current, open state	mA	–	≤ 1.5
Current consumption, no-load	mA	≤ 10	–
Maximum switching frequency	Hz	100	25
Delays	First-up	ms	≤ 30
	Response	ms	≤ 5
	Recovery	ms	≤ 5

3

(1) Cable gland not included with sensor. For suitable Pg 13 cable gland (XSZPE13), see page 2/133.

(2) These sensors do not incorporate overload or short-circuit protection. A fast-acting fuse must be connected in series with the load.

Wiring diagrams

3-wire ⋯
NO + NC output

2-wire ~ programmable
NO or NC output, depending on position of link

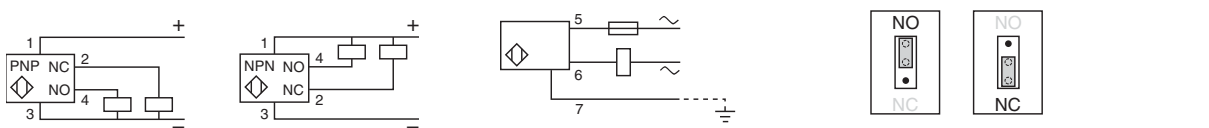

Setup

Minimum mounting distances (mm)

XT7 flush mountable

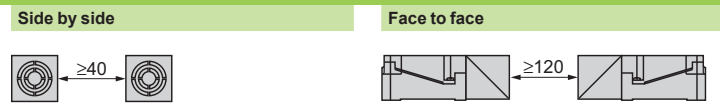

Flush mounting

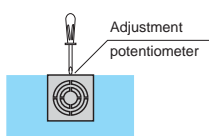

To avoid interference by the immediate surroundings, it may be necessary to reduce the sensitivity when flush mounting the sensor.