

Sensors

Proximity, Photoelectric, and Ultrasonic Sensors, Limit Switches, Pressure Sensors, Machine Safety, Encoders, RFID, and Machine Cabling



7—Machine Safety Light Curtains and Cable Pull Switches

Light curtains

Selection Guide: Light curtains 7/2

Overview 7/6

Light curtains, type 4

For finger or hand protection

- Optimum light curtains with solid state output, type XUSLB 7/8
- Universal light curtains with solid state output, type XUSLD 7/8
- Substitution table 7/20
- Muting module for XUSLDM universal light curtains, type XPSLCM1 7/22

For body protection

- Compact light curtains with solid-state output, type XUSLP
- with connector 7/28
- with terminal block 7/30

Light curtains, type 2

For hand protection

- Slim, compact light curtains with solid-state output, type XUSLN 7/36

For body protection

- Preventa® safety modules and single-beam photo-electric sensors, type XPSCM 7/48

Accessories for light curtains types 2 and 4 7/40

Light Curtain Application and Installation

Protection of personnel 7/56

Standards and basic requirements 7/57

Minimum safety distances 7/58

- United States 7/58
- Europe 7/60
- Special rules for presses 7/61

Prevention of access to hazardous area 7/62

Light curtain alignment 7/63

Using mirrors 7/64

Minimum object sensitivity (MOS) 7/65

Fixed and floating blanking 7/66

Test procedure for the United States 7/67



Cable pull switches

Selection Guide: Cable Pull Switches 7/68

Cable pull switches type XY2 C

- Specifications 7/70
- Selection 7/72
- Accessories 7/73

Safety detection solutions

Light curtains

Applications		Machine tool, material handling, automotive, etc.	
Functions		Finger protection: 0.55 in. (14 mm), or hand protection: 1.18 in. (30 mm)	
Device		Light curtains, type 4	
		Multi-beam, infrared transmission, light curtains (1 transmitter-receiver pair)	
		Optimum Type	Universal Type
			
Conformity		Product standards	
		ANSI/RIA R15.06, ANSI B11:19-1990, OSHA 1910.217(C), OSHA 1910.212, EN/IEC 61496-1 and EN/IEC 61496-2 and IEC 61508-1, 2 (Type 4 ESPE)	
		European directives	
		Machinery directive 98/37/EC, Work equipment directive 89/655/EEC and EMC directive 89/336 EEC ROHS directive 2002/95/EC	
Product certifications		CE, TUV, UL, CSA	
Degree of protection		IP 65	
Cross-section		1.50 x 1.97 in. (38 x 50 mm)	
Protected height		Conforming to EN 999	
		11 to 53.5 in. (280 to 1360 mm) (finger protection) 12.6 to 83.5 in. (320 to 2120 mm) (hand protection)	
Nominal sensing distance		1 to 23 ft (finger protection) 1 to 65 ft (hand protection)	
Response time		Depending on height protected: 23 to 41 ms (finger protection) Depending on height protected: 23 to 32 ms (hand protection)	
Type of outputs		Safety	
		2 solid-state PNP outputs (N.O.) --- 24 V, ≤ 625 mA Short-circuit protection	
		Auxiliary	
		1 solid-state 100 mA, --- 24 V, PNP or NPN output depending on the model	
Main functions		<ul style="list-style-type: none"> - Auto/manual - Test - EDM (External Devices Monitoring) - Light beam coding 	
Muting function (inhibition of the light curtain Detection function)		<ul style="list-style-type: none"> - Auto/manual - Test - EDM (External Devices Monitoring) - Light beam coding - Blanking (fixed and floating) - Cascadable (up to 4 segments) - Muting 	
Supply voltage		--- 24 V ± 20%, 2 A	
Catalog numbers		XUSLB	XUSLD
Pages		7/10	7/11

7

Applications		Packaging, conveyor systems, materials handling, warehousing, stocking, etc.
Functions		Body protection (300, 400, 500 and 600 mm)
Device		<p>Light curtains, type 4</p> <p>1 to 6 beam light curtains with infrared transmission (1 transmitter-receiver pair)</p> <p>Type 4 model, solid-state output</p>
		
Conformity	Product standards	ANSI/RIA R15.06, ANSI B11:19-1990, OSHA 1910.217(C), OSHA 1910.212, type 4 (ESPE) conforming to IEC 61496-1 and 2
	European directives	Machinery directive 98/37/EC, Work equipment directive 89/655/EEC and EMC directive 89/336/EEC
Product certifications		CE, TUV, UL, CSA
Degree of protection		IP 67
Cross-section		2.05 x 2.17 in. (52 x 55 mm)
Protected height	Conforming to EN 999	29.53–70.87 in. (750–1800 mm) (1 to 6 light beams)
Nominal sensing distance		0.8–20 m or 0.8–70 m dpg. on configuration 0.8–8 m for light curtains with passive receiver
Response time		< 16 to < 24 ms, depending on the light beam coding selected
Type of outputs	Safety	2 solid-state PNP outputs (N.O.) ~ 24 V, ≤ 650 mA Short-circuit protection
	Auxiliary	1 solid-state 100 mA, ~ 24 V PNP output
Main functions		Functions integrated in the light curtain: Auto/Manual start and manual 1st cycle, - EDM (external devices monitoring), - test input, - 3 light beam codings available, - Muting via external module
Muting function (inhibition of the light curtain Detection function)		
Supply voltage		~ 24 V ± 20%, 2 A
Catalog numbers		XUSLP●●●●
Pages		7/29

Applications	Packaging, conveyor systems, materials handling, warehousing, stocking, etc.	
Functions	Hand protection (30 mm)	
Device	Light curtains, type 2 Multi-beam light curtains with infrared transmission (1 transmitter-receiver pair) Slim, compact model, solid-state output Automatic or manual start	
		
Conformity	Product standards	IEC 61496-1 and IEC 61496-2 type 2 (ESPE)
	European directives	Machinery directive 98/37/EC, Work equipment directive 89/655/EEC and EMC directive 89/336/EEC
Product certifications	CE, TUV, UL, CSA	
Degree of protection	IP 65	
Cross-section	1.12 x 1.26 in. (28.5 x 32 mm)	
Protected height	Conforming to EN 999	5.91–59.06 in. (150–1500 mm) (hand protection)
Nominal sensing distance	0.98–49.21 ft (0.3–15 m)	
Response time	14–24 ms	
Type of outputs	Safety	2 solid-state PNP outputs (N.O.) $\bar{\text{---}}$ 24 V, \leq 500 mA Short-circuit protection
	Auxiliary	1 x 100 mA, $\bar{\text{---}}$ 24 V PNP alarm output
Main functions	Functions integrated in the light curtain: - automatic or manual start, depending on the version	
Muting function (inhibition of the light curtain Detection function)	- Muting via external module	
Supply voltage	$\bar{\text{---}}$ 24 V \pm 20%, 2 A	
Catalog numbers	XUSLNG5C●●●●, XUSLNG5D●●●●	
Pages	7/37	

7

Packaging, conveyor systems, materials handling, warehousing, stocking, etc.

Body protection

Light curtains, type 2

Single-beam, infrared transmission, light curtains (Preventa® safety monitoring module plus 1–4 thru-beam photoelectric sensors)

Type 2 model, relay outputs (N.O.)



IEC 60947-1, EN 61496-1, EN 60825-1, UL 508, type 2 (ESPE) conforming to IEC 61496-1 and 2

Machinery directive 98/37/EC, Work equipment directive 89/655/EEC and EMC directive 89/336/EEC EN 60825-1 (emission class 1)

CE type approval BIA/Cologne. UL, CSA

IP 67

Ø of sensors: 18 mm

29.5 to 47.2 in. (750 to 1200 mm) (1–4 light beams)

26.2 ft (8 m)

< 20 ms (sensors + safety module)

Solid-state PNP
Preventa® safety module XPSCM outputs
2 guided contact relays, each 1 N.O.
AC-15: C300, 1800 VA inrush, 180 VA maintained
DC-13: ∩ 24 V/1.5 A, L/R = 50 ms
Maximum thermal current = 2.5 A

∩ 24 V, 20 mA

Muting integrated in the safety monitoring module XPSCM

Safety module XPSCM: ∩ 24 V (19–29 V)
Sensors XU2S: ∩ 24 V (10–30 V)

XU2S●●●●●● + XPSCM

7/50

7

Introduction

Protection of personnel

Light curtains are electro-sensitive protection equipment (ESPE) designed to help protect persons operating or working in the vicinity of machinery, by stopping the dangerous movement of parts as soon as one of the light beams is broken. In particular, they help provide protection for personnel operating dangerous machinery (annex IV of 98/37/EC) but they are equally suitable for use with many other types of machines. They make it possible to help protect personnel while allowing free access to machines.

The absence of a door or guard reduces the time required for loading, inspection or adjustment operations, and makes access easier.

Directives and standards

Conformity to standards

These light curtains conform to the following:

- European Machinery Safety Directive 98/37/EC and European Work Equipment Directive 89/655/EEC,
- Low Voltage Directives 73/23/EEC and 93/68/EEC and also, the Electromagnetic Compatibility Directive 89/336/EEC,
- Standard EN/IEC 61496-1, EN/IEC 61496-2 (electro-sensitive protection equipment: ESPE),
- Standard EN 60825 (emission power),
- Standard EN 999/ISO 13855 (installation positioning).

These light curtains are UL, CSA and TÜV certified.

Applications

Main applications

- Applications for type 2 products:
 - assembly and packaging lines,
 - conveying and handling lines,
 - warehousing and storage systems,
 - waste disposal skips.
- Types of machine requiring the use of type 4 products:
 - presses (all types), shears and trimmers,
 - hoisting equipment,
 - saws (all types),
 - machine tools (lathes, milling machines, machining centers),
 - woodworking machines (planing machines, lathes, spindle molding machines, side and face milling cutters),
 - textile machinery (carding machines, weaving looms, steam rooms),
 - assembly machines,
 - assembly robots.

7

Safety requirements

Detection of anomalies

Detection of anomalies liable to compromise safety, and stopping of the machine

The design of the machine and its control system must be to the same level of safety as that of the light curtain in order to provide the immediate stopping of the machine's dangerous movement as soon as the hazardous zone (protected by the light curtain) is entered.

It must not be possible to enter the protected zone without breaking the protective light beams. The light curtain must therefore be installed in such a manner that the light beams cannot be avoided.

The machine can only be restarted if no danger exists and no personnel are present in the hazardous zone. The risk that persons might be inside the protected zone but out of the protective light beams must be addressed.

Functions

Protection mode

AUTO/MAN (automatic/manual): This is what standard EN/IEC 61496 calls start (or restart) interlock of the light curtain:

- In Auto mode: Upon power-up or after the beams have been cleared, the light curtain resets itself automatically (closing of the OSSD output safety circuits),
- In Manual mode: Upon power-up or after the beams have been cleared, the light curtain keeps its output safety circuits in the Open position. Pressing and releasing the reset button will reset the light curtain and close its OSSD output safety circuits.

Note: In all cases, a general start instruction for the machine will trigger its actual start-up.

Monitoring the external switching devices

Also called EDM (external device monitoring) by standard EN/IEC 61496, this consists of monitoring the state (open or closed) of the machine's power switching components, along with the time taken to reach that state.

Auxiliary output

Where configurable (XUSLM/XUSLP), this is a low power solid-state output for signaling to the automation system. This output closes when the light curtain switches to run mode.

Alarm

This is a low power solid-state output for signaling to the automation system. This output closes when the light curtain switches to alarm mode.

Signaling

LED display of operating modes and alarm.

Alignment aid

Display by visible infrared LED of each beam broken.

Muting (inhibition)

When activated, the Muting function inhibits the Detection function of the light curtain.

Activation (or deactivation) is achieved by means of standard sensors (photoelectric or other). When activated, a signal is sent to the automation system. This function is used to allow objects to access the hazardous zones during the process. Signaling informs the operator or operators that they are not protected.

Blanking

While the Muting function inhibits *all* beams in the light curtain from detecting objects, the Blanking function inhibits a *selected* group of light beams. This allows objects to be present during process operations. Blanking is adaptable to the size of the objects present.

Blanking effectively increases the Minimum Object Sensitivity (MOS). This imposes a greater safety distance, increasing the minimum distance between the light curtain and the hazard. Also, additional protection on each side of the object present must be provided, in order to prevent any intrusion into the free areas.

Floating blanking

This function makes it possible to inhibit one or two light beams (adjacent or otherwise), anywhere in the light curtain. This configuration is used, for example, for metal plate feeding applications on folding presses or shears.

Blanking plus floating blanking

The Blanking function (fixed inhibition of light beams) and Floating Blanking function (moving inhibition of one or two light beams) can be combined.

Safety detection solutions

Safety light curtains, type 4
Optimum XUSLB and Universal XUSLDM
with solid-state output

Light curtain type		XUSLBQ6A●●●● XUSLDMQ6A●●●● 0.55 in. (14 mm)	XUSLBR5A●●●● 1.18 in. (30 mm)	XUSLDMY5A●●●●● 1.18 in. (30 mm)
Environmental specifications				
Conformity to standards		ANSI/RIA R15.06, ANSI B11:19-1990, OSHA 1910.217(C), OSHA 1910.212, EN/IEC 61496-1 and EN/IEC 61496-2 and IEC 61508-1, 2 (Type 4 ESPE)		
Certifications		CE, TUV, UL, CSA		
European directives		Machinery directive 98/37/EC, Work equipment directive 89/655/EEC and EMC directive 89/336 EEC ROHS directive 2002/95/EC		
Maximum safety level (1)		Category 4 conforming to IEC 61496-1 and 2. PL = e, category 4 conforming to EN/ISO 13849-1 and EN/IEC 61508		
Reliability data B _{10d}		PFH _d = 4.9E ⁻⁶ 1/h conforming to EN/IEC 61508		
Ambient air temperature	Operating	°F (°C)	14 to +131 (-10 to +55)	
	Storage	°F (°C)	-13 to +167 (-25 to +75)	
Relative humidity		95% maximum, without condensation		
Degree of protection		IP 65		
Shock and vibration resistance	Conforming to IEC 61496-1	Shock resistance: 10 gn, impulse 16 ms Vibration resistance: 10–55 Hz, amplitude: 0.35 ± 0.05 mm		
Materials		Casing: aluminium with electrostatically applied red (RAL 3000) polyester paint finish; end caps: 20% fiberglass impregnated polycarbonate. Lens: PMMA (polymethyl methacrylate).		
Mounting		End brackets (included)		
Optical specifications				
Minimum detection capacity (MOS)		0.55 in. (14 mm) (finger)	1.18 in. (30 mm) (hand)	
Nominal sensing distance (Sn)	ft (m)	1–23 (0.3–7) or 9.8 (3) with PDM (2)	1–26.2 (0.3–8) or 65.6 (20) with PDM (2)	1–65.6 (0.3–20) or 26.2 (8) with PDM (2)
Protected height	in. (mm)	11–53.5 (280–1360)	12.6–83.5 (320–2120)	
Effective aperture angle (EAA)		2.5° at 9.8ft (3 m) (3° when used with IP 67 protection tube)		
Light source		GaAlAs LED, 880 nm		
Immunity to ambient light		Conforming to IEC/EN 61496-2		
Electrical specifications				
Response time	ms	23–41	23–32	
Power supply	Transmitter	--- 24 V ± 20% 2 A conforming to EN/IEC 61496 and EN/IEC 60204-1		
	Receiver	mA	285	
Maximum current consumption (no-load)	Transmitter	mA	285	
	Receiver	mA	450	
Immunity to interference		Conforming to EN 61496-1		
Safety outputs OSSD (Output Signal Switching Devices)		2 solid-state PNP (N/O) outputs ≤ 625 mA, --- 24 V (Short-circuit protected)		
Auxiliary output		1 solid-state output 100 mA, --- 24 V, PNP or NPN (depending on the model)		
Monitoring activation of output switching devices (MPCE/EDM)		50 mA, --- 24 V and start/restart 10 mA		
Signaling	Transmitter	1 LED (power supply)		
	Receiver	4 LEDs (stop, run, interlock, ECS/B Blanking or FB Floating Blanking)		
Connections (3)	Light curtains	Transmitter	M12, 5-pin, female connector	
		Receiver	M12, 8-pin, female connector	
	Segments XUSLDS XPSLCM1	Transmitter/Receiver	M12, 4-pin, female connector on flying lead	
		Receiver	M12, 4-pin, female connector	
Pre-wired connectors c.s.a.	Transmitter/Receiver	22 AWG (0.32 mm ²) conductors with M12, 5-pin, male connector		
	Receiver	22 AWG (0.32 mm ²) conductors with M12, 8-pin, male connector		
Jumper cables c.s.a.	Transmitter/receiver	22 AWG (0.32 mm ²) conductors with M12, 4-pin, male/female connectors		
Cable resistance of pre-wired connectors	Transmitter/receiver	Ω	0.1686 per ft (0.05531 per m)	
Cable lengths		Pre-wired connectors with cable lengths of 16.4, 32.8, 49.2, and 98.4 ft (5, 10, 15 and 30 m) are available separately. The maximum cable length is 196.9 ft (60 m), depending on the load current and power supply.		

(1) Using an appropriate and correctly connected control system.
(2) PDM: Programming and Diagnostic Module, available as an option. See page 7/14.
(3) Pre-wired connectors must be ordered separately. See page 7/14.

Safety detection solutions

Safety light curtains, type 4 Optimum XUSLB and Universal XUSLDM with solid-state output

Light curtain type		XUSLB●●●●●●	XUSLDM●●●●●●
Functions			
Functions	Accessible by cabling alone (1)	<input type="checkbox"/> Automatic start <input type="checkbox"/> Auxiliary output (PNP, status signaling) <input type="checkbox"/> Test (MTS: Monitoring Test Signal) <input type="checkbox"/> Alignment aid by display of each light beam broken <input type="checkbox"/> LED display of operating modes and anomalies	
	Accessible via programming and diagnostic module	<input type="checkbox"/> Auto/Manual <input type="checkbox"/> Monitoring of the external switching devices (EDM: external device monitoring) <input type="checkbox"/> Light beam coding (A or B) <input type="checkbox"/> Sensing distance (short, long) <input type="checkbox"/> Programming and downloading the configuration settings, via programming and diagnostic module (PDM) <input type="checkbox"/> Display of operating modes and anomalies by LED or PDM (2)	<input type="checkbox"/> Auto/Manual, manual 1st cycle <input type="checkbox"/> Monitoring of the external switching devices (EDM: external device monitoring) <input type="checkbox"/> Blanking (ECS/B) <input type="checkbox"/> Monitored Blanking <input type="checkbox"/> Floating Blanking (FB) <input type="checkbox"/> Reduction of resolution <input type="checkbox"/> Response time (normal, slow) <input type="checkbox"/> Light beam coding (A or B) <input type="checkbox"/> Sensing distance (short, long) <input type="checkbox"/> Auxiliary output (alarm or status signaling, PNP or NPN) <input type="checkbox"/> Start button (N/O or N/C, 0 V or 24 V) <input type="checkbox"/> Muting (see page 7/7) <input type="checkbox"/> Cascadable versions with up to 4 segments total (256 light beams max., modular finger/hand) using XUSLDS segments <input type="checkbox"/> Programming and downloading the configuration settings, via programming and diagnostic module (PDM) <input type="checkbox"/> Display of operating modes and anomalies by LED or PDM (2)
Monitoring the external switching devices (EDM: external device monitoring)		Monitoring of the function (open or closed) as well as the response time of the power components.	
Test function		Initiates the stop instruction of the light curtain by opening the contact (simulated intrusion)	
Muting function (inhibition)		<input type="checkbox"/> With external module XPSLCM1150	<input type="checkbox"/> Integrated when using connection module XPSLCM1 for connecting sensors and Muting indicator light <input type="checkbox"/> or with module XPSLCM1150

(1) Not requiring use of PDM.

(2) PDM: Programming and Diagnostic Module, available as an option. See page 7/14.

Safety detection solutions

Safety light curtains, type 4

Optimum XUSLB with solid-state output



XUSLBQ6A●●●●



XUSLBR5A●●●●

7

Transmitter-receiver pairs for finger protection (1)

Detection capacity: 0.55 in. (14 mm).

Sensing distance: 1 to 22.9 ft (0.3 to 7 m), or 9.8 ft (3 m) with PDM.

■ 2 PNP safety outputs

Protected height	Response time	Number of light beams	Auxiliary output	Catalog number (2)	Weight
in. (mm)	ms				lb (kg)
11 (280)	23	24	PNP	XUSLBQ6A0280	3.95 (1.790)
12.6 (320)	23	32	PNP	XUSLBQ6A0320	4.34 (1.970)
14.2 (360)	23	36	PNP	XUSLBQ6A0360	4.74 (2.150)
17.3 (440)	23	44	PNP	XUSLBQ6A0440	5.51 (2.500)
20.5 (520)	23	52	PNP	XUSLBQ6A0520	6.33 (2.870)
23.6 (600)	23	60	PNP	XUSLBQ6A0600	7.10 (3.220)
28.3 (720)	32	72	PNP	XUSLBQ6A0720	8.29 (3.760)
29.9 (760)	32	76	PNP	XUSLBQ6A0760	8.69 (3.940)
34.6 (880)	32	88	PNP	XUSLBQ6A0880	9.85 (4.470)
36.2 (920)	32	92	PNP	XUSLBQ6A0920	10.25 (4.650)
37.8 (960)	32	96	PNP	XUSLBQ6A0960	10.65 (4.830)
40.9 (1040)	32	104	PNP	XUSLBQ6A1040	11.44 (5.190)
44.1 (1120)	32	112	PNP	XUSLBQ6A1120	12.21 (5.540)
47.2 (1200)	32	120	PNP	XUSLBQ6A1200	13.01 (5.900)
53.5 (1360)	41	136	PNP	XUSLBQ6A1360	13.62 (6.180)

Transmitter-receiver pairs for hand protection (1)

Detection capacity: 1.18 in. (30 mm).

Sensing distance: 1 to 26.2 ft (0.3 to 8 m), or 65.6 ft (20 m) with PDM.

■ 2 PNP safety outputs

Protected height	Response time	Number of light beams	Auxiliary output	Catalog number (2)	Weight
in. (mm)	ms				lb (kg)
12.6 (320)	23	16	PNP	XUSLBR5A0320	4.34 (1.970)
14.2 (360)	23	18	PNP	XUSLBR5A0360	4.74 (2.150)
17.3 (440)	23	22	PNP	XUSLBR5A0440	5.51 (2.500)
20.5 (520)	23	26	PNP	XUSLBR5A0520	6.33 (2.870)
23.6 (600)	23	30	PNP	XUSLBR5A0600	7.10 (3.220)
26.8 (680)	23	34	PNP	XUSLBR5A0680	7.89 (3.580)
29.9 (760)	23	38	PNP	XUSLBR5A0760	8.69 (3.940)
34.6 (880)	23	44	PNP	XUSLBR5A0880	9.85 (4.470)
36.2 (920)	23	46	PNP	XUSLBR5A0920	10.25 (4.650)
40.9 (1040)	23	52	PNP	XUSLBR5A1040	11.44 (5.190)
47.2 (1200)	23	60	PNP	XUSLBR5A1200	13.01 (5.900)
53.5 (1360)	23	68	PNP	XUSLBR5A1360	14.59 (6.620)
55.1 (1400)	23	70	PNP	XUSLBR5A1400	14.99 (6.800)
59.8 (1520)	32	76	PNP	XUSLBR5A1520	16.16 (7.330)
61.4 (1560)	32	78	PNP	XUSLBR5A1560	16.53 (7.500)
64.6 (1640)	32	82	PNP	XUSLBR5A1640	17.35 (7.870)
67.7 (1720)	32	86	PNP	XUSLBR5A1720	18.14 (8.230)
70.9 (1800)	32	88	PNP	XUSLBR5A1800	18.94 (8.590)
75.6 (1920)	32	96	PNP	XUSLBR5A1920	20.11 (9.120)
83.5 (2120)	32	106	PNP	XUSLBR5A2120	22.09 (10.020)

(1) Includes a test rod, 2 sets of 2 brackets with mounting hardware, a user guide with the certificate of conformity on CD-ROM, and 1 arc suppressor set.

Programming and Diagnostic Module (if required) and pre-wired connectors must be ordered separately. See page 7/14.

(2) To order a receiver only, add the letter **R** to the end of the catalog number for the corresponding transmitter-receiver pair.

Example: XUSLBR5A0320 becomes **XUSLBR5A0320R** for the receiver only.

To order a transmitter only, add the letter **T** to the end of the catalog number for the corresponding transmitter-receiver pair.

Example: XUSLBR5A0320 becomes **XUSLBR5A0320T** for the transmitter only.

Other versions

Combining type 4 safety light curtains with external module for Muting function. See page 2/218 of the *Machine Safety Products* catalog, MKTED208051EN-US.

Separate components and accessories: page 7/14

Safety detection solutions

Safety light curtains, type 4

Universal XUSLDM with solid-state output



XUSLDMQ.....



XUSLDMY.....

Transmitter-receiver pairs for finger protection (1)

Detection capacity: 0.55 in. (14 mm).

Sensing distance: 1 to 22.9 ft (0.3 to 7 m) (or 9.8 ft (3 m) with PDM).

■ 2 PNP safety outputs

Protected height	Response time		Number of light beams	Auxiliary output	Catalog number (2)	Weight
	Normal	Slow				
in. (mm)	ms	ms				lb (kg)
11 (280)	23	38	24	PNP/NPN	XUSLDMQ6A0280	3.95 (1.790)
12.6 (320)	23	38	32	PNP/NPN	XUSLDMQ6A0320	4.34 (1.970)
14.2 (360)	23	38	36	PNP/NPN	XUSLDMQ6A0360	4.74 (2.150)
17.3 (440)	23	38	44	PNP/NPN	XUSLDMQ6A0440	5.51 (2.500)
20.5 (520)	23	38	52	PNP/NPN	XUSLDMQ6A0520	6.39 (2.900)
23.6 (600)	23	38	60	PNP/NPN	XUSLDMQ6A0600	7.10 (3.220)
28.3 (720)	32	53	72	PNP/NPN	XUSLDMQ6A0720	8.29 (3.760)
29.9 (760)	32	53	76	PNP/NPN	XUSLDMQ6A0760	8.69 (3.940)
34.6 (880)	32	53	88	PNP/NPN	XUSLDMQ6A0880	9.85 (4.470)
36.2 (920)	32	53	92	PNP/NPN	XUSLDMQ6A0920	10.25 (4.650)
37.8 (960)	32	53	96	PNP/NPN	XUSLDMQ6A0960	10.65 (4.830)
40.9 (1040)	32	53	104	PNP/NPN	XUSLDMQ6A1040	11.44 (5.190)
44.1 (1120)	32	53	112	PNP/NPN	XUSLDMQ6A1120	12.21 (5.540)
47.2 (1200)	32	53	120	PNP/NPN	XUSLDMQ6A1200	13.01 (5.900)
53.5 (1360)	41	68	136	PNP/NPN	XUSLDMQ6A1360	14.59 (6.620)

Transmitter-receiver pairs for hand protection (1)

Detection capacity: 1.18 in. (30 mm).

Sensing distance: 1 to 65.6 ft (0.3 to 20 m), or 26.2 ft (8 m) with PDM.

■ 2 PNP safety outputs

Protected height	Response time		Number of light beams	Auxiliary output	Catalog number (2)	Weight
	Normal	Slow				
in. (mm)	ms	ms				lb (kg)
12.6 (320)	23	38	16	PNP/NPN	XUSLDMY5A0320	4.34 (1.970)
14.2 (360)	23	38	18	PNP/NPN	XUSLDMY5A0360	4.74 (2.150)
17.3 (440)	23	38	22	PNP/NPN	XUSLDMY5A0440	5.51 (2.500)
20.5 (520)	23	38	26	PNP/NPN	XUSLDMY5A0520	6.33 (2.870)
23.6 (600)	23	38	30	PNP/NPN	XUSLDMY5A0600	7.10 (3.220)
26.8 (680)	23	38	34	PNP/NPN	XUSLDMY5A0680	7.89 (3.580)
29.9 (760)	23	38	38	PNP/NPN	XUSLDMY5A0760	8.69 (3.940)
34.6 (880)	23	38	44	PNP/NPN	XUSLDMY5A0880	9.85 (4.470)
36.2 (920)	23	38	46	PNP/NPN	XUSLDMY5A0920	10.25 (4.650)
40.9 (1040)	23	38	52	PNP/NPN	XUSLDMY5A1040	11.44 (5.190)
47.2 (1200)	23	38	60	PNP/NPN	XUSLDMY5A1200	13.01 (5.900)
53.5 (1360)	23	38	68	PNP/NPN	XUSLDMY5A1360	14.59 (6.620)
55.1 (1400)	23	38	70	PNP/NPN	XUSLDMY5A1400	14.99 (6.800)
59.8 (1520)	32	53	76	PNP/NPN	XUSLDMY5A1520	16.16 (7.330)
61.4 (1560)	32	53	78	PNP/NPN	XUSLDMY5A1560	16.53 (7.500)
64.6 (1640)	32	53	82	PNP/NPN	XUSLDMY5A1640	17.35 (7.870)
67.7 (1720)	32	53	86	PNP/NPN	XUSLDMY5A1720	18.14 (8.230)
70.9 (1800)	32	53	88	PNP/NPN	XUSLDMY5A1800	18.94 (8.590)
75.6 (1920)	32	53	96	PNP/NPN	XUSLDMY5A1920	20.11 (9.120)
83.5 (2120)	32	53	106	PNP/NPN	XUSLDMY5A2120	22.09 (10.020)

(1) Includes a test rod, 2 sets of 2 brackets with mounting hardware, user guide with certificate of conformity on CD-ROM and 1 arc suppressor set.

Programming and Diagnostic Module (if required) and pre-wired connectors must be ordered separately. See page 7/14.

(2) To order a receiver only, add the letter **R** to the end of the catalog number for the corresponding transmitter-receiver pair.

Example: XUSLDMY5A0320 becomes **XUSLDMY5A0320R** for the receiver only.

To order a transmitter only, add the letter **T** to the end of the catalog number for the corresponding transmitter-receiver pair.

Example: XUSLDMY5A0320 becomes **XUSLDMY5A0320T** for the transmitter only.

Other versions

Combining type 4 safety light curtains with external module for Muting function. See page 2/218 of the *Machine Safety Products* catalog, MKTED208051EN-US.

Separate components and accessories: page 7/14

Safety detection solutions

Safety light curtains, type 4

XUSLDS segments for Universal XUSLDM light curtains



XUSLDM + XUSLDS

Segments for cascadable Universal light curtains

Cascadable versions with up to 4 segments total (256 light beams max., modular finger/hand), using XUSLDS segments

Configuration of XUSLDS segments

Two segments

Number of light beams	Response time ms
0 to 65	23
66 to 120	32
121 to 174	41
175 to 229	50
230 to 256	59

Three segments

Number of light beams	Response time ms
0 to 59	23
60 to 114	32
115 to 168	41
169 to 223	50
224 to 256	59

Four segments

Number of light beams	Response time ms
0 to 53	23
54 to 108	32
109 to 162	41
163 to 217	50
218 to 256	59

Separate components and accessories: page 7/14

Safety detection solutions

Safety light curtains, type 4

XUSLDS segments for Universal XUSLDM light curtains



XUSLDSQ6A●●●●

Transmitter-receiver pairs for finger protection (1)

Detection capacity: 0.55 in. (14 mm).

Sensing distance: depends on XUSLDM light curtain used.

■ Segments for cascadable Universal light curtains (2)

Protected height	Number of light beams	Catalog number (3)	Weight
in. (mm)			lb (kg)
11 (280)	24	XUSLDSQ6A0280	3.95 (1.790)
12.6 (320)	32	XUSLDSQ6A0320	4.34 (1.970)
14.2 (360)	36	XUSLDSQ6A0360	4.74 (2.150)
17.3 (440)	44	XUSLDSQ6A0440	5.51 (2.500)
20.5 (520)	52	XUSLDSQ6A0520	6.33 (2.870)
23.6 (600)	60	XUSLDSQ6A0600	7.10 (3.220)
28.3 (720)	72	XUSLDSQ6A0720	8.29 (3.760)
29.9 (760)	76	XUSLDSQ6A0760	8.69 (3.940)
34.6 (880)	88	XUSLDSQ6A0880	9.85 (4.470)
36.2 (920)	92	XUSLDSQ6A0920	10.25 (4.650)
37.8 (960)	96	XUSLDSQ6A0960	10.65 (4.830)
40.9 (1040)	104	XUSLDSQ6A1040	11.44 (5.190)
44.1 (1120)	112	XUSLDSQ6A1120	12.21 (5.540)
47.2 (1200)	120	XUSLDSQ6A1200	13.01 (5.900)



XUSLDSY5A●●●●

Transmitter-receiver pairs for hand protection (1)

Detection capacity: 1.18 in. (30 mm).

Sensing distance: depends on XUSLDM light curtain used.

■ Segments for cascadable Universal light curtains (2)

Protected height	Number of light beams	Catalog number (3)	Weight
in. (mm)			lb (kg)
12.6 (320)	16	XUSLDSY5A0320	4.34 (1.970)
14.2 (360)	18	XUSLDSY5A0360	4.74 (2.150)
17.3 (440)	22	XUSLDSY5A0440	5.51 (2.500)
20.5 (520)	26	XUSLDSY5A0520	6.33 (2.870)
23.6 (600)	30	XUSLDSY5A0600	7.10 (3.220)
26.8 (680)	34	XUSLDSY5A0680	7.89 (3.580)
29.9 (760)	38	XUSLDSY5A0760	8.69 (3.940)
34.6 (880)	44	XUSLDSY5A0880	9.85 (4.470)
36.2 (920)	46	XUSLDSY5A0920	10.25 (4.650)
40.9 (1040)	52	XUSLDSY5A1040	11.44 (5.190)
47.2 (1200)	60	XUSLDSY5A1200	13.01 (5.900)
53.5 (1360)	68	XUSLDSY5A1360	14.59 (6.620)
55.1 (1400)	70	XUSLDSY5A1400	14.99 (6.800)
59.8 (1520)	76	XUSLDSY5A1520	16.16 (7.330)
61.4 (1560)	78	XUSLDSY5A1560	16.53 (7.500)
64.6 (1640)	82	XUSLDSY5A1640	17.35 (7.870)
67.7 (1720)	86	XUSLDSY5A1720	18.14 (8.230)
70.9 (1800)	88	XUSLDSY5A1800	18.94 (8.590)
75.6 (1920)	96	XUSLDSY5A1920	20.11 (9.120)
83.5 (2120)	106	XUSLDSY5A2120	22.09 (10.020)

(1) Includes 2 sets of 2 brackets and hardware.

Jumper cables must be ordered separately. See page 7/14.

(2) The segments are to be connected to the M12 4-pin connector on top of the XUSLDM light curtains.

(3) To order a receiver only, add the letter **R** to the end of the catalog number for the corresponding transmitter-receiver pair.

Example: XUSLDSY5A0320 becomes **XUSLDSY5A0320R** for the receiver only.

To order a transmitter only, add the letter **T** to the end of the catalog number for the corresponding transmitter-receiver pair.

Example: XUSLDSY5A0320 becomes **XUSLDSY5A0320T** for the transmitter only.

Separate components and accessories: page 7/14



Safety detection solutions

Safety light curtains, type 4

Optimum XUSLB and Universal XUSLDM/LDS

With solid-state output



XUSLPDM

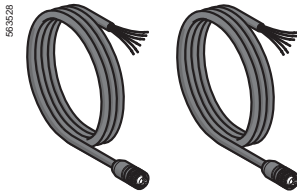

XSZBCT05

XSZBCR10

Separate components

Power supplies, 90° mirror adapters, protective covers, anti-vibration kit, mounting bases, laser alignment tool

See pages 7/15 and 7/40 to 7/47.

Accessories

Description	For use with	Length ft (m)	Catalog number	Weight lb (kg)		
Programming and Diagnostic Module (PDM)	XUSLB/LDM light curtains	–	XUSLPDM	0.62 (0.280)		
Holder mount	Programming and diagnostic module XUSLPDM	–	XUSLZPDM	0.09 (0.040)		
Pre-wired connectors for light curtains XUSLB/XUSLDM	Transmitter type	16.4 (5)	XSZBCT05	0.86 (0.390)		
		32.8 (10)	XSZBCT10	1.52 (0.690)		
		49.2 (15)	XSZBCT15	2.27 (1.030)		
		98.4 (30)	XSZBCT30	4.25 (1.930)		
	Receiver type	16.4 (5)	XSZBCR05	0.99 (0.450)		
		32.8 (10)	XSZBCR10	1.72 (0.780)		
Jumper cables for XUSLDS segments M12 male/female, 4-pin, straight	Transmitter type	1 (0.3)	XSZDCT003	0.11 (0.050)		
		1.6 (0.5)	XSZDCT005	0.15 (0.070)		
		3.3 (1)	XSZDCT010	0.24 (0.110)		
		6.6 (2)	XSZDCT020	0.46 (0.210)		
		9.9 (3)	XSZDCT030	0.66 (0.300)		
		16.4 (5)	XSZDCT050	1.08 (0.490)		
	Receiver type	32.8 (10)	XSZDCT100	2.09 (0.950)		
		1 (0.3)	XSZDCR003	0.11 (0.050)		
		1.6 (0.5)	XSZDCR005	0.15 (0.070)		
		3.3 (1)	XSZDCR010	0.24 (0.110)		
		6.6 (2)	XSZDCR020	0.46 (0.210)		
		9.9 (3)	XSZDCR030	0.66 (0.300)		
		16.4 (5)	XSZDCR050	1.08 (0.490)		
		32.8 (10)	XSZDCR100	2.12 (0.960)		
		Jumpers for replacing XUSLT light curtains with XUSLB or XUSLDM	Transmitter type Male/Female 5 pins	1 (0.3)	XSZTBDMCT003	0.13 (0.060)
			Receiver type Male/Female 8 pins	1 (0.3)	XSZTBDMCR003	0.13 (0.060)
		Replacement caps for M12 connector (Sold in lots of 10)	XUSLDM light curtains and XUSLDS segments		XUSLZ600	0.002 (0.001)
		Replacement caps for M8 connector (programming and diagnostic module XUSLPDM connection to light curtains) (Sold in lots of 10)	XUSLB/LDM light curtains and XUSLDS segments		XUSLZ610	0.02 (0.010)
Mounting kit (2 brackets)	XUSLB/LDM light curtains and XUSLDS segments		XUSLZ228	0.22 (0.100)		
Sliding nuts (4 nuts) for rear or side mounting with XUSLZ228	XUSLB/LDM light curtains		XUSLZ330	0.09 (0.040)		
Arc suppressor (pair)	All light curtain types		XUSLZ500	0.04 (0.020)		
IP 67 protection tube (see page 7/15)				–		
User guide on CD-ROM	All light curtain types		XUSLZ450	0.02 (0.010)		
Connection module for sensors and muting indicator light (see page 7/22)	XUSLDM light curtains		XPPLCM1	0.42 (0.190)		

Safety detection solutions

Safety light curtains, type 4
XUSLB/XUSLDM protection tubes for light curtains
with solid-state output and XUSLDS segments

IP 67 protection tubes for XUSLB/XUSLDM light curtains and XUSLDS segments		XUSLZD7●●●●	
Environmental specifications			
Air temperature	Operating	°F (°C)	32 to +104 (0 to +40)
	Storage	°F (°C)	-13 to +158 (-25 to +70)
Degree of protection			IP 67 conforming to IEC 60529
Material			Acrylic
Sensing distance (Sn) reduction coefficient			0.90

Environmental chemicals			
Chemical resistance	Aliphatic hydrocarbons		Resistant
	Alkalis		
	Aqueous solutions		
	Detergents and cleaners		
	Inorganic diluted acids		
	Chlorinated or aromatic hydrocarbons		Limited resistance
	Esters		
	Ketones		
Environmental resistance	Adverse weather, sunlight (UV)		Resistant
	Humidity		
	Immersion in water		

Catalog numbers of IP 67 protection tubes

100046



XUSLZD7●●●●

Description	For use with	Height in. (mm)	Catalog number	Weight lb (kg)
IP 67 protection tubes for XUSLB/LDM transmitter-receiver pair and XUSLDS●●●● segments (0.90 Sn) (1) (Sold in lots of 2)	XUSL●●●6A0280	11.2 (284.4)	XUSLZD70280	5.84 (2.650)
	XUSL●●●A0320	12.8 (324.8)	XUSLZD70320	6.19 (2.810)
	XUSL●●●A0360	14.4 (364.5)	XUSLZD70360	6.53 (2.960)
	XUSL●●●A0440	17.5 (443.9)	XUSLZD70440	7.21 (3.270)
	XUSL●●●A0520	20.6 (523.4)	XUSLZD70520	7.89 (3.580)
	XUSL●●●A0600	23.8 (604.1)	XUSLZD70600	8.58 (3.890)
	XUSL●●●5A0680	26.9 (683.6)	XUSLZD70680	9.24 (4.190)
	XUSL●●●6A0720	28.5 (724)	XUSLZD70720	9.59 (4.350)
	XUSL●●●A0760	30 (763)	XUSLZD70760	9.92 (4.500)
	XUSL●●●A0880	34.8 (882.8)	XUSLZD70880	10.93 (4.960)
	XUSL●●●A0920	36.3 (922.5)	XUSLZD70920	11.28 (5.120)
	XUSL●●●6A0960	37.9 (963.6)	XUSLZD70960	11.62 (5.270)
	XUSL●●●A1040	41.1 (1042.9)	XUSLZD71040	12.30 (5.580)
	XUSL●●●6A1120	44.2 (1122.3)	XUSLZD71120	12.99 (5.890)
	XUSL●●●A1200	47.4 (1203.8)	XUSLZD71200	13.67 (6.200)
	XUSL●●●A1360	53.6 (1362)	XUSLZD71360	15.01 (6.810)
	XUSL●●●5A1400	55.2 (1401.7)	XUSLZD71400	15.37 (6.970)
	XUSL●●●5A1520	59.9 (1521.5)	XUSLZD71520	16.38 (7.430)
	XUSL●●●5A1560	61.5 (1563.3)	XUSLZD71560	16.71 (7.580)
	XUSL●●●5A1640	64.6 (1641.3)	XUSLZD71640	17.89 (7.890)
XUSL●●●5A1720	67.7 (1720.8)	XUSLZD71720	18.08 (8.200)	
XUSL●●●5A1800	71 (1802.9)	XUSLZD71800	18.76 (8.510)	
XUSL●●●5A1920	75.7 (1922.8)	XUSLZD71920	19.78 (8.970)	
XUSL●●●5A2120	83.5 (2120.7)	XUSLZD72120	21.47 (9.740)	

(1) Sensing distance reduction coefficient must be taken into account for each pair of IP 67 protection tubes used.

7

Safety detection solutions

Preventa®

Safety light curtains, type 4
Optimum XUSLB and Universal XUSLDM
with solid-state output

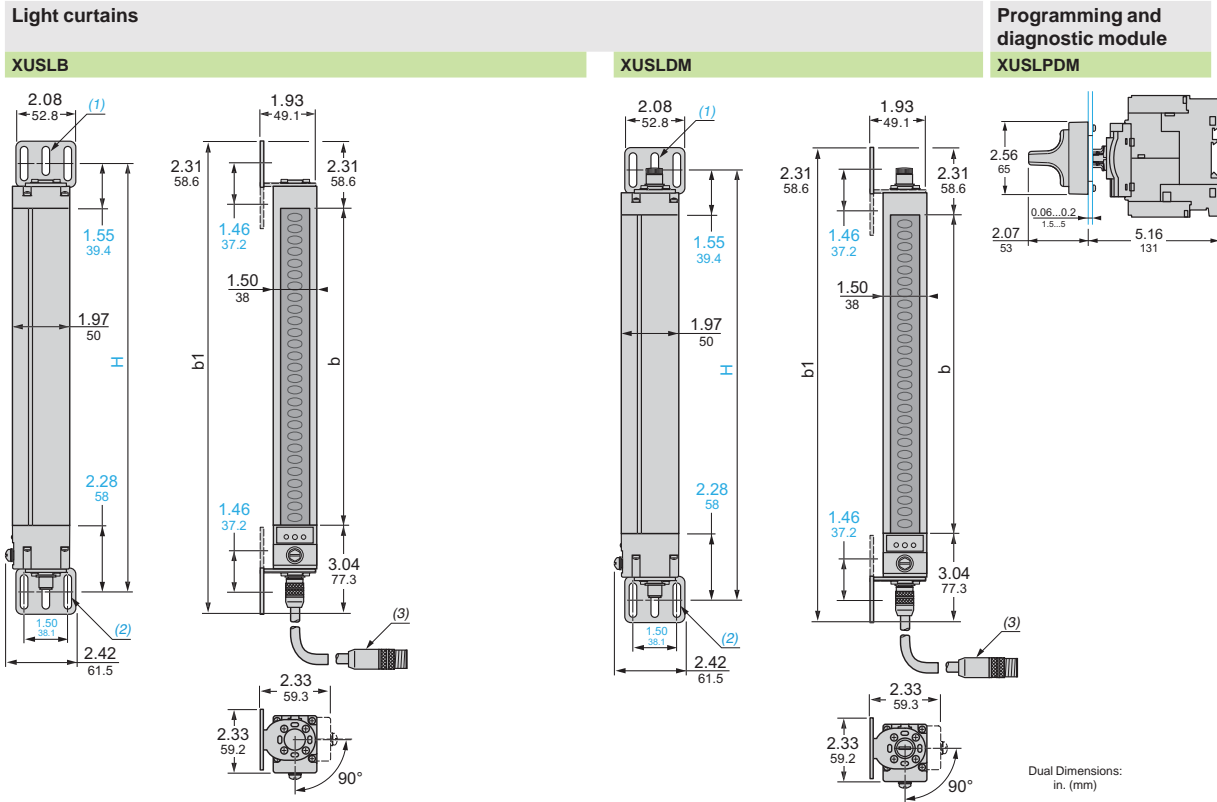

XUS	b	b1	H	Protected height
LB●●0280	11.2 (284.4)	16.6 (420.4)	15 (381.7)	11 (280)
LB●●0320	12.8 (324.8)	18.1 (460.8)	16.6 (422.1)	12.6 (320)
LB●●0360	14.4 (364.5)	19.7 (500.5)	18.2 (461.8)	14.2 (360)
LB●●0440	17.5 (443.9)	22.8 (579.9)	21.3 (541.2)	17.3 (440)
LB●●0520	20.6 (523.4)	26 (659.4)	24.4 (620.7)	20.5 (520)
LB●●0600	23.8 (604.1)	29.1 (740.1)	27.6 (701.4)	23.6 (600)
LB●●0680	26.9 (683.6)	32.3 (819.6)	30.7 (780.9)	26.8 (680)
LB●●0720	28.5 (724)	33.9 (860)	32.3 (821.3)	28.3 (720)
LB●●0760	30 (763)	35.4 (899)	33.9 (860.3)	29.9 (760)
LB●●0880	34.8 (882.8)	40.1 (1018.8)	38.6 (980.1)	34.6 (880)
LB●●0920	36.3 (922.5)	41.7 (1058.5)	40.1 (1019.8)	36.2 (920)
LB●●0960	37.9 (963.6)	43.3 (1099.6)	41.8 (1060.9)	37.8 (960)
LB●●1040	41.1 (1042.9)	46.4 (1178.9)	44.9 (1140.2)	40.9 (1040)
LB●●1120	44.2 (1122.3)	49.5 (1258.3)	48 (1219.6)	44.1 (1120)
LB●●1200	47.4 (1203.8)	52.7 (1339.8)	51.2 (1301.1)	47.2 (1200)
LB●●1360	53.6 (1362)	59 (1498)	57.5 (1459.3)	53.5 (1360)
LB●●1400	55.2 (1401.7)	60.5 (1537.7)	59 (1499)	55.1 (1400)
LB●●1520	59.9 (1521.5)	65.3 (1657.5)	63.7 (1618.8)	59.8 (1520)
LB●●1560	61.5 (1563.3)	66.9 (1699.3)	65.4 (1660.6)	61.4 (1560)
LB●●1640	64.6 (1641.3)	70 (1777.3)	68.4 (1738.6)	64.6 (1640)
LB●●1720	67.7 (1720.8)	73.1 (1856.8)	71.6 (1818.1)	67.7 (1720)
LB●●1800	71 (1802.9)	76.3 (1938.9)	74.8 (1900.2)	70.9 (1800)
LB●●1920	75.7 (1922.8)	81.1 (2058.8)	79.5 (2020.1)	75.6 (1920)
LB●●2120	83.5 (2120.7)	88.8 (2256.7)	87.3 (2217.3)	83.5 (2120)

XUS	b	b1	H	Protected height
LDM●●0280	11.2 (284.4)	16.6 (420.4)	15 (381.7)	11 (280)
LDM●●0320	12.8 (324.8)	18.1 (460.8)	16.6 (422.1)	12.6 (320)
LDM●●0360	14.4 (364.5)	19.7 (500.5)	18.2 (461.8)	14.2 (360)
LDM●●0440	17.5 (443.9)	22.8 (579.9)	21.3 (541.2)	17.3 (440)
LDM●●0520	20.6 (523.4)	26 (659.4)	24.4 (620.7)	20.5 (520)
LDM●●0600	23.8 (604.1)	29.1 (740.1)	27.6 (701.4)	23.6 (600)
LDM●●0680	26.9 (683.6)	32.3 (819.6)	30.7 (780.9)	26.8 (680)
LDM●●0720	28.5 (724)	33.9 (860)	32.3 (821.3)	28.3 (720)
LDM●●0760	30 (763)	35.4 (899)	33.9 (860.3)	29.9 (760)
LDM●●0880	34.8 (882.8)	40.1 (1018.8)	38.6 (980.1)	34.6 (880)
LDM●●0920	36.3 (922.5)	41.7 (1058.5)	40.1 (1019.8)	36.2 (920)
LDM●●0960	37.9 (963.6)	43.3 (1099.6)	41.8 (1060.9)	37.8 (960)
LDM●●1040	41.1 (1042.9)	46.4 (1178.9)	44.9 (1140.2)	40.9 (1040)
LDM●●1120	44.2 (1122.3)	49.5 (1258.3)	48 (1219.6)	44.1 (1120)
LDM●●1200	47.4 (1203.8)	52.7 (1339.8)	51.2 (1301.1)	47.2 (1200)
LDM●●1360	53.6 (1362)	59 (1498)	57.5 (1459.3)	53.5 (1360)
LDM●●1400	55.2 (1401.7)	60.5 (1537.7)	59 (1499)	55.1 (1400)
LDM●●1520	59.9 (1521.5)	65.3 (1657.5)	63.7 (1618.8)	59.8 (1520)
LDM●●1560	61.5 (1563.3)	66.9 (1699.3)	65.4 (1660.6)	61.4 (1560)
LDM●●1640	64.6 (1641.3)	70 (1777.3)	68.4 (1738.6)	64.6 (1640)
LDM●●1720	67.7 (1720.8)	73.1 (1856.8)	71.6 (1818.1)	67.7 (1720)
LDM●●1800	71 (1802.9)	76.3 (1938.9)	74.8 (1900.2)	70.9 (1800)
LDM●●1920	75.7 (1922.8)	81.1 (2058.8)	79.5 (2020.1)	75.6 (1920)
LDM●●2120	83.5 (2120.7)	88.8 (2256.7)	87.3 (2217.3)	83.5 (2120)

(1) 2 elongated holes, 0.73 x 0.27 in. (18.5 x 6.8 mm).

(2) 4 elongated holes, 0.91 x 0.27 in. (23.2 x 6.8 mm).

(3) M12 male connector on 10.6 in. (0.27 m) pigtail.

**Cascadable segments
XUSLDS**

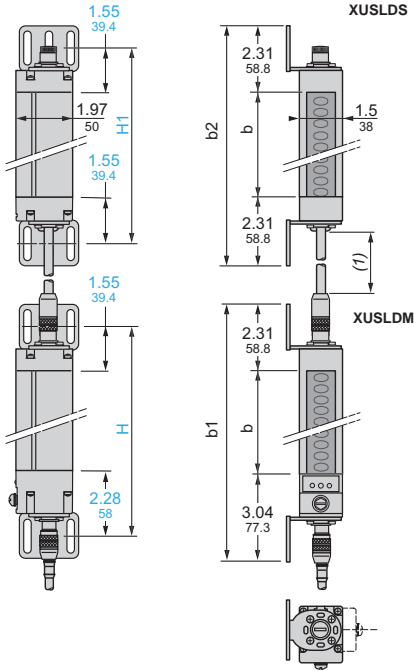

XUS	b	b1	b2	H	H1	Protected height
LDS●●●0280	11.2 (284.4)	16.6 (420.4)	15.8 (401.5)	15 (381.7)	14.3 (363.1)	11 (280)
LDS●●●0320	12.8 (324.8)	18.1 (460.8)	17.4 (442.3)	16.6 (422.1)	15.9 (403.5)	12.6 (320)
LDS●●●0360	14.4 (364.5)	19.7 (500.5)	19 (482)	18.2 (461.8)	17.4 (443.2)	14.2 (360)
LDS●●●0440	17.5 (443.9)	22.8 (579.9)	22.1 (561.4)	21.3 (541.2)	20.6 (522.6)	17.3 (440)
LDS●●●0520	20.6 (523.4)	26 (659.4)	25.2 (640.9)	24.4 (620.7)	23.7 (602.1)	20.5 (520)
LDS●●●0600	23.8 (604.1)	29.1 (740.1)	28.4 (721.6)	27.6 (701.4)	26.9 (682.8)	23.6 (600)
LDS●●●0680	26.9 (683.6)	32.3 (819.6)	31.5 (801.1)	30.7 (780.9)	30 (762.3)	26.8 (680)
LDS●●●0720	28.5 (724)	33.9 (860)	33.1 (841.5)	32.3 (821.3)	31.6 (802.7)	28.3 (720)
LDS●●●0760	30 (763)	35.4 (899)	34.7 (880.5)	33.9 (860.3)	33.1 (841.7)	29.9 (760)
LDS●●●0880	34.8 (882.8)	40.1 (1018.8)	39.4 (1000.3)	38.6 (980.1)	37.9 (961.5)	34.6 (880)
LDS●●●0920	36.3 (922.5)	41.7 (1058.5)	40.9 (1040)	40.1 (1019.8)	39.4 (1001.2)	36.2 (920)
LDS●●●0960	37.9 (963.6)	43.3 (1099.6)	42.6 (1081.1)	41.8 (1060.9)	41 (1042.3)	37.8 (960)
LDS●●●1040	41.1 (1042.9)	46.4 (1178.9)	45.7 (1160.4)	44.9 (1140.2)	44.2 (1121.6)	40.9 (1040)
LDS●●●1120	44.2 (1122.3)	49.5 (1258.3)	48.8 (1239.8)	48 (1219.6)	47.3 (1201)	44.1 (1120)
LDS●●●1200	47.4 (1203.8)	52.7 (1339.8)	52 (1321.3)	51.2 (1301.1)	50.5 (1282.5)	47.2 (1200)
LDS●●●1360	53.6 (1362)	59 (1498)	58.2 (1479.5)	57.5 (1459.3)	56.7 (1440.7)	53.5 (1360)
LDS●●●1400	55.2 (1401.7)	60.5 (1537.7)	59.8 (1519.2)	59 (1499)	58.3 (1480.4)	55.1 (1400)
LDS●●●1520	59.9 (1521.5)	65.3 (1657.5)	64.5 (1639)	63.7 (1618.8)	63 (1600.2)	59.8 (1520)
LDS●●●1560	61.5 (1563.3)	66.9 (1699.3)	66.2 (1680.8)	65.4 (1660.6)	66.1 (1679.2)	61.4 (1560)
LDS●●●1640	64.6 (1641.3)	70 (1777.3)	69.2 (1758.8)	68.4 (1738.6)	67.7 (1720)	64.6 (1640)
LDS●●●1720	67.7 (1720.8)	73.1 (1856.8)	72.4 (1838.3)	71.6 (1818.1)	70.8 (1799.5)	67.7 (1720)
LDS●●●1800	71 (1802.9)	76.3 (1938.9)	75.6 (1920.4)	74.8 (1900.2)	74.1 (1881.6)	70.9 (1800)
LDS●●●1920	75.7 (1922.8)	81.1 (2058.8)	80.3 (2040.3)	79.5 (2020.1)	78.8 (2001.5)	75.6 (1920)
LDS●●●2120	83.5 (2120.7)	88.8 (2256.7)	88.1 (2237.5)	87.3 (2217.3)	86.6 (2198.7)	83.5 (2120)

(1) Flexible 4.33 in. (0.11 m) cable.

Protection tube for XUSLB/XUSLDM light curtains and XUSLDS segments

XUSLZD7●●●●

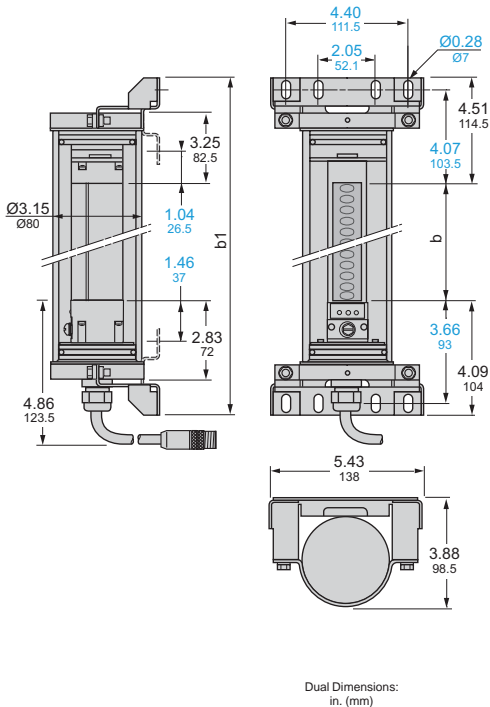

XUS	b	b1	XUS	b	b1
LZD70280	11.2 (284.4)	19.8 (502.8)	LZD71040	41.1 (1042.9)	49.7 (1261.3)
LZD70320	12.8 (324.8)	21.4 (543.2)	LZD71120	44.2 (1122.3)	52.8 (1340.7)
LZD70360	14.4 (364.5)	22.9 (582.9)	LZD71200	47.4 (1203.8)	56 (1422.2)
LZD70440	17.5 (443.9)	26.1 (662.3)	LZD71360	53.6 (1362)	62.2 (1580.4)
LZD70520	20.6 (523.4)	29.2 (741.8)	LZD71400	55.2 (1401.7)	63.8 (1620.1)
LZD70600	23.8 (604.1)	32.4 (822.5)	LZD71520	59.9 (1521.5)	68.5 (1739.9)
LZD70680	26.9 (683.6)	35.5 (902)	LZD71560	61.5 (1563.3)	70.1 (1781.7)
LZD70720	28.5 (724)	37.1 (942.4)	LZD71640	64.6 (1641.3)	73.2 (1859.2)
LZD70760	30 (763)	38.6 (981.4)	LZD71720	67.7 (1720.8)	76.3 (1939.2)
LZD70880	34.8 (882.8)	43.4 (1101.2)	LZD71800	71 (1802.9)	79.6 (2021.2)
LZD70920	36.3 (922.5)	44.9 (1140.9)	LZD71920	75.7 (1922.8)	84.3 (2141.2)
LZD70960	37.9 (963.6)	46.5 (1182)	LZD72120	83.5 (2120.7)	92.1 (2338.4)

Direct connection with XUSLB/LDM●●●

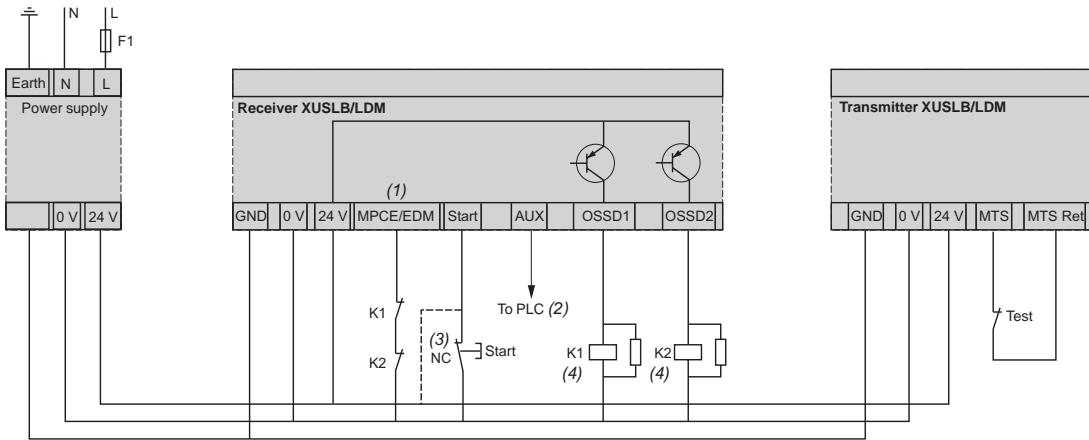

- (1) For testing prior to installation, you can select MPCE/EDM OFF (factory default setting). In that case, the MPCE/EDM line must be connected to the 0 V line of the system.
- (2) The auxiliary output connects to a PLC (optional).
- (3) If remote start is not used, connect the start line to the 0 V line.
- (4) The K1 and K2 coils must be protected using the arc suppressors included in the documentation kit.

Note: Relays K1 and K2 must have mechanically linked contacts.

Connection via a Preventa® XPSAFL module

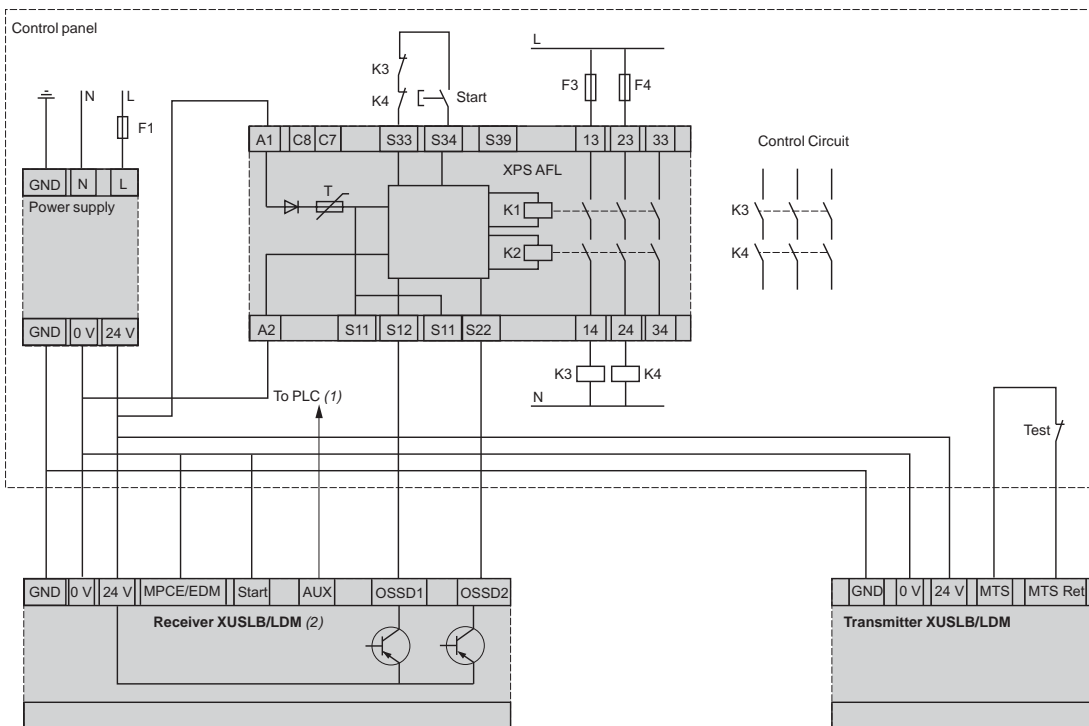

- (1) The auxiliary output connects to a PLC (optional).
- (2) The light curtain must be configured with MPCE/EDM OFF and with automatic start.

Note: Relays K3 and K4 must have mechanically linked contacts.

Safety detection solutions

Safety light curtains, type 4
Optimum XUSLB and Universal XUSLDM
with solid-state output

Transmitter

Transmitter connector

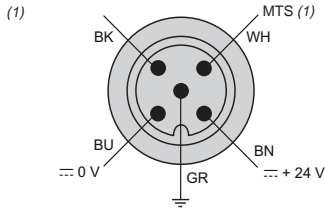

Transmitter status indicator



1 Yellow LED

(1) Light curtain test input.

Receiver

Receiver connector

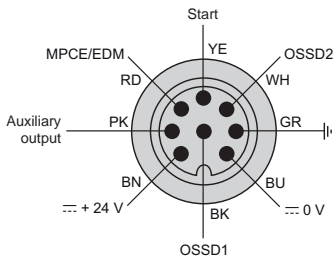

Receiver status indicator

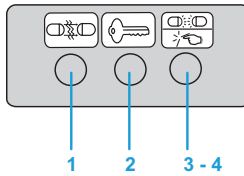

1 Blanking: Orange LED
2 Interlock or Alarm: Yellow LED
3-4 Machine run: Green LED
Machine stop: Red LED

Programming and diagnostic module

Description and connection to XUSLB/XUSLDM light curtains

XUSLPDM

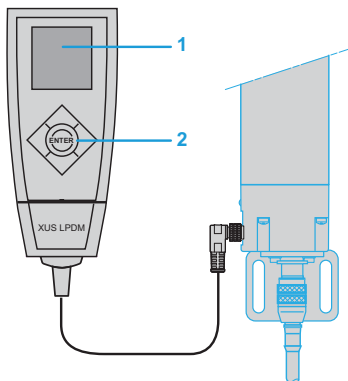

1 Screen
2 Navigation button for displaying menus and selecting functions

Substitution table

Light curtains with the closest functionalities

Safety detection solutions

Safety light curtains, type 4
Optimum XUSLB and Universal XUSLDM
with solid-state output

Optimum light curtains	
Detection capacity: 0.55 in. (14 mm).	
Old light curtain	New light curtain
XUSLTQ6A0260, XUSLTQ6B0260	XUSLBQ6A0280
XUSLTQ6A0350, XUSLTQ6B0350	XUSLBQ6A0320, XUSLBQ6A0360
XUSLTQ6A0435, XUSLTQ6B0435	XUSLBQ6A0440
XUSLTQ6A0520, XUSLTQ6B0520	XUSLBQ6A0520
XUSLTQ6A0610, XUSLTQ6B0610	XUSLBQ6A0600
XUSLTQ6A0700, XUSLTQ6B0700	XUSLBQ6A0720
XUSLTQ6A0785, XUSLTQ6B0785	XUSLBQ6A0760
XUSLTQ6A0870, XUSLTQ6B0870	XUSLBQ6A0880, XUSLBQ6A0920
XUSLTQ6A0955, XUSLTQ6B0955	XUSLBQ6A0960
XUSLTQ6A1045, XUSLTQ6B1045	XUSLBQ6A1040
XUSLTQ6A1130, XUSLTQ6B1130	XUSLBQ6A1120
XUSLTQ6A1215, XUSLTQ6B1215	XUSLBQ6A1200
XUSLTQ6A1305, XUSLTQ6B1390, XUSLTQ6A1390, XUSLTQ6B1390	XUSLBQ6A1360
Detection capacity: 1.18 in. (30 mm)	
Old light curtain	New light curtain
XUSLTR5A0350, XUSLTR5B0350	XUSLBR5A0320, XUSLBR5A0360, XUSLBR5A0440
XUSLTR5A0520, XUSLTR5B0520	XUSLBR5A0520, XUSLBR5A0600
XUSLTR5A0700, XUSLTR5B0700	XUSLBR5A0680, XUSLBR5A0760
XUSLTR5A0870, XUSLTR5A0870,	XUSLBR5A0880, XUSLBR5A0920
XUSLTR5A1045, XUSLTR5B1045	XUSLBR5A1040
XUSLTR5A1215, XUSLTR5B1215	XUSLBR5A1200, XUSLBR5A1360
XUSLTR5A1390, XUSLTR5B1390	XUSLBR5A1400, XUSLBR5A1520
XUSLTR5A1570, XUSLTR5B1570	XUSLBR5A1560, XUSLBR5A1640
XUSLTR5A1745, XUSLTR5B1745	XUSLBR5A1720, XUSLBR5A1800
XUSLTR5A1920, XUSLTR5B1920	XUSLBR5A1920
XUSLTR5A2095, XUSLTR5B2095	XUSLBR5A2120

Note: The characteristics of the ranges (optics, connections, dimensions, mounting, functions, etc.) are not exactly the same.

Please refer to the detailed characteristics of the XUSLB●●●●●● and XUSLD●●●●●● ranges and associated accessories when replacing a light curtain from the XUSLT●●●●●● range.



Substitution table

Light curtains with the
closest functionalities

Safety detection solutions

Safety light curtains, type 4
Optimum XUSLB and Universal XUSLDM
with solid-state output

Universal light curtains	
Detection capacity: 1.18 in. (30 mm)	
Old light curtain	New light curtain
XUSLTY5A0350, XUSLTY5B0350	XUSLDMY5A0320, XUSLDMY5A0360, XUSLDMY5A0440
XUSLTY5A0520, XUSLTY5B0520	XUSLDMY5A0520, XUSLDMY5A0600
XUSLTY5A0700, XUSLTY5B0700	XUSLDMY5A0680, XUSLDMY5A0760
XUSLTY5A0870, XUSLTY5B0870	XUSLDMY5A0880, XUSLDMY5A0920
XUSLTY5A1045, XUSLTY5B1045	XUSLDMY5A1040
XUSLTY5A1215, XUSLTY5B1215	XUSLDMY5A1200, XUSLDMY5A1360
XUSLTY5A1390, XUSLTY5B1390	XUSLDMY5A1400, XUSLDMY5A1520
XUSLTY5A1570, XUSLTY5B1570	XUSLDMY5A1560, XUSLDMY5A1640
XUSLTY5A1745, XUSLTY5B1745	XUSLDMY5A1720, XUSLDMY5A1800
XUSLTY5A1920, XUSLTY5B1920	XUSLDMY5A1920
XUSLTY5A2095, XUSLTY5B2095	XUSLDMY5A2120

Note: The characteristics of the ranges (optics, connections, dimensions, mounting, functions, etc.) are not exactly the same.

Please refer to the detailed characteristics of the XUSLB●●●●●● and XUSLD●●●●●● ranges and associated accessories when replacing a light curtain from the XUSLT●●●●●● range.

Safety detection solutions

Preventa® connection module XPSLCM1 for Muting function on XUSLDM light curtains

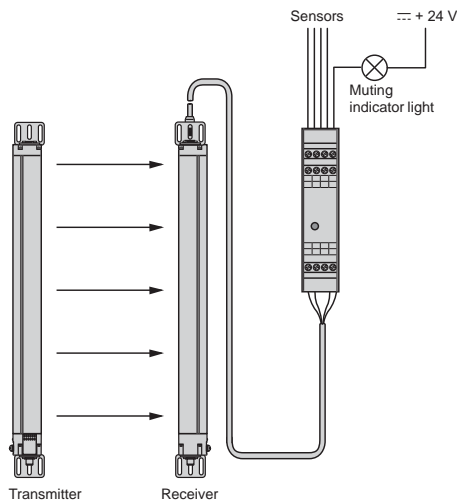

Operating principle

Universal XUSLDM light curtains have an integrated Muting function that is configurable using the XUSLPDM programming and diagnostic module. This function allows for the automatic passage of loaded pallets or parts for machining, without interrupting the transportation movement within the zone protected by the electro-sensitive protection equipment (ESPE) system. In addition to the safety light curtain, an XPSLCM1 connection module, which is connected directly to the top of the light curtain receiver, allows for the cabling of 2–4 muting sensors as well as an indicator light. In the event of a sequence error, the muting indicator light flashes (1 second interval); turning the Start key switch off and on restarts the system.

When the system is switched on by the start command, and the light curtain protection not interrupted, the main circuit is closed by the safety outputs of the XUSLDM light curtain (solid-state safety outputs). In addition to the safety outputs, the light curtain incorporates signaling LEDs and an auxiliary output (alarm or status signaling) for sending system status information to the PLC. Four LEDs on the light curtain and one on the front face of the XPSLCM1 connection module provide information on the safety circuit status.

An interruption of the protection field monitored by the electro-sensitive protection equipment causes instantaneous opening of the safety outputs; the process PLC receives a stop command, and the LED display mounted on the front face indicates the change of state of the safety circuits. The Open state is maintained until the light beams are unobstructed and, if included in the light curtain configuration, the Start key switch operated.

The Muting function cannot be activated by energizing the muting sensors unless the safety outputs have been closed beforehand. To trigger the Muting function, the muting devices must be activated within the configurable time interval (50 ms to 5 seconds, in increments of 50 ms). During the activated muting phase, materials can be transported through the protection field without deactivating the safety outputs. In the event of intrusion into the hazardous zone, a person cannot activate the muting sensors in the same way, and the system stops.

While the Muting function is activated, a muting status indicator light is controlled by the XPSLCM1 connection module. The indicator light illuminates only when a muting signal is generated, and indicates the inhibition of the protection function. An indicator light error (short-circuit, open circuit) is immediately recognized and deactivates the Muting function.

Conditions to be observed for the Muting function

- The muting sensors must either be
 - thru-beam: XUK 0ARCTL2 (sensing distance 98.4 ft / 30 m) + XUK 0ARCTL2T
 - polarized reflex: XUK 0ARCTL2 (sensing distance 16.4 ft / 5 m) + reflector XUZ C50 or mechanical limit switches with contacts.
- $dM \leq m$ to obtain continuous validation of the Muting function.
- Avoid the intrusion of persons during the muting phase. This phase is indicated by the indicator light connected to the muting indicator output of the XPSLCM1 connection module.
- A materials trolley must provide the muting signal before entering the protection field, and interrupt the muting signal on exiting once it has cleared all the sensors of the protection field.

7

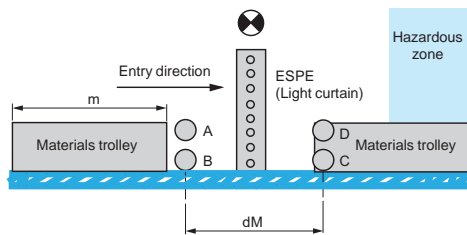

ESPE: electro-sensitive protection equipment (light curtain)
 A, B, D, C: muting sensors
 m: trolley length
 dM: distance between A, B and D, C

Safety detection solutions

Preventa® connection module XPSLCM1
for Muting function on
XUSLDM light curtains

Specifications		
Connection module type		XPSLCM1
Maximum achievable safety level (1)		PL e/Category 4 conforming to EN/ISO 13849-1, SILCL 3 conforming to EN/IEC 62061
Conformity to standards		EN/IEC 61496-1, EN/IEC 61496-2, EN/IEC 60204-1, EN/IEC 60947-1, EN/IEC 60947-5-1
Certifications		CE, TÜV, CSA, UL
Product designed for max. use in safety related parts of control systems	Conforming to EN 954-1/ISO 13849-1	Category 4
Ambient air temperature	Operating	°F (°C) 32 to +131 (0 to +55)
	Storage	°F (°C) -13 to +167 (-25 to +75)
Degree of protection conforming to IEC 529	Terminals	IP 20
	Enclosure	IP 20
Power supply by XUSLDM light curtain	Voltage	V --- 24 (±20%)
	Maximum current	mA 30
Maximum consumption		W 0.7
Rated insulation voltage (Ui)		V 500
Rated impulse withstand voltage (Uimp)		kV 1.1
Shock resistance	Conforming to IEC 68-2-6	gn 6 (10–55 Hz)
Vibration resistance	Conforming to IEC 68-2-29	gn 10 (16 ms)
Number of light curtains that can be connected		1 transmitter-receiver pair
Inputs for muting sensors		
- number of inputs to be monitored		2–4 per Muting function
- supply voltage of sensors		V --- 24
- output current of each sensor		mA < 20
Type of muting sensors		Thru-beam, polarized reflex or sensors with volt-free contacts
Synchronization time of muting sensors		ms 50 to 500 (configurable in XUSLDM light curtain in increments of 50 ms)
Maximum muting time		min 2 or unlimited
Safety outputs		
- number and type		2 PNP (terminals 1 and 2)
- breaking capacity of outputs		mA 30 V/100
Muting indicator light output		1 NPN
Muting indicator light power		W 1 to 7 max.
Muting indicator light type		LED or filament bulb
Signaling		1 LED
Connection		
1-wire connection	Type	Captive screw clamp terminals, nonremovable
	Without cable end	Solid or flexible cable: 26-14 AWG (0.14–2.5 mm ²)
	With cable end	Without bezel, flexible cable: 24-14 AWG (0.25–2.5 mm ²)
2-wire connection	With cable end	With bezel, flexible cable: 24-16 AWG (0.25–1.5 mm ²)
	Without cable end	Without bezel, flexible cable: 24-18 AWG (0.25–1.0 mm ²)
	Without cable end	Double, with bezel, flexible cable: 22-16 AWG (0.5–1.5 mm ²)

(1) Using an appropriate and correctly connected control system.

**Description,
Catalog Numbers,
Dimensions**

Safety detection solutions
Preventa® connection module XPSLCM1
for Muting function on
XUSLDM light curtains

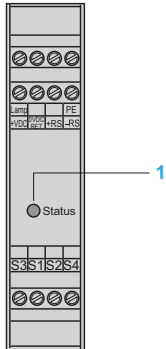

Description

XPSLCM1
To aid diagnostics, the connection module has 1 LED on the front face **1**.

Catalog Numbers

Connection module					
Description	Type of terminal block connection	Muting indicator light output	Supply	Catalog number	Weight oz (kg)
Connection module for Muting function	Nonremovable	1 NPN	~ 24 V	XPSLCM1	6.70 (0.190)

Spare parts

Description	Power W	Catalog number	Weight oz (kg)
Muting indicator light kit (1)	5	XSZCM01	0.42 (0.012)
Replacement bulbs for muting indicator light kit comprising one lot of 10 replacement bulbs and 1 removal/insertion tool XBF X13	1 to 7	XSZCM02	0.56 (0.016)

(1) XVB or XVD with steady light LED or filament bulb can also be used.

Dimensions

XPSLCM1

Mounting on 35 mm rail

7

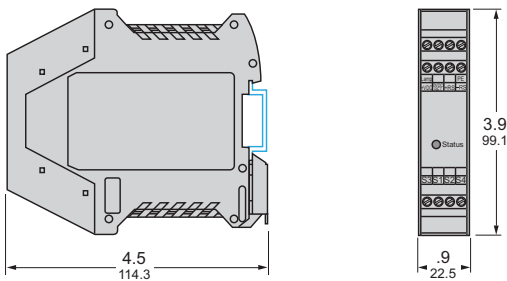

Muting indicator light kit XSZ CM01

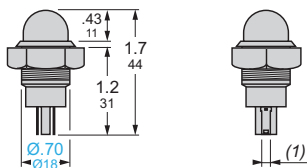

(1) Faston connector 4.7.

Dual Dimensions:
in. (mm)

Safety detection solutions

Preventa® connection module XPSLCM1
for Muting function on
XUSLDM light curtains

Connection of XUSLDM light curtains with connection module XPSLCM1

Example configuration with XUSLDM light curtains

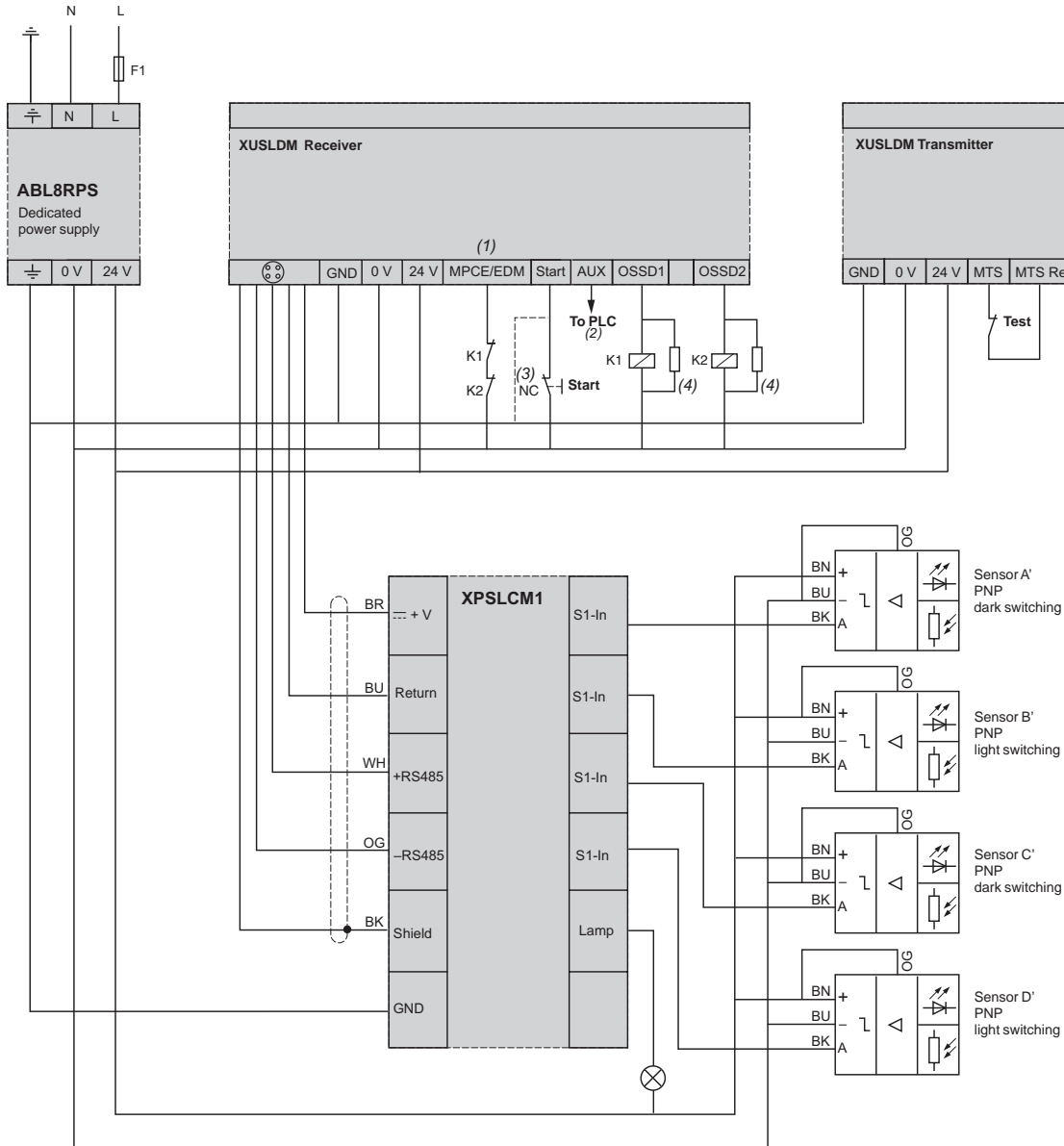

(1) For testing prior to installation, you can select MPCE/EDM OFF (factory default setting). In that case, the MPCE/EDM line must be connected to the 0 V line of the system.

(2) The auxiliary output connects to a PLC (optional).

(3) If remote start is not used, connect the start line to the 0 V line.

(4) The K1 and K2 coils must be protected using the arc suppressors included in the documentation kit.

Functional diagram of XUSLDM light curtain with connection module XPSLCM1

Start/Restart Interlock mode with 2 sensors

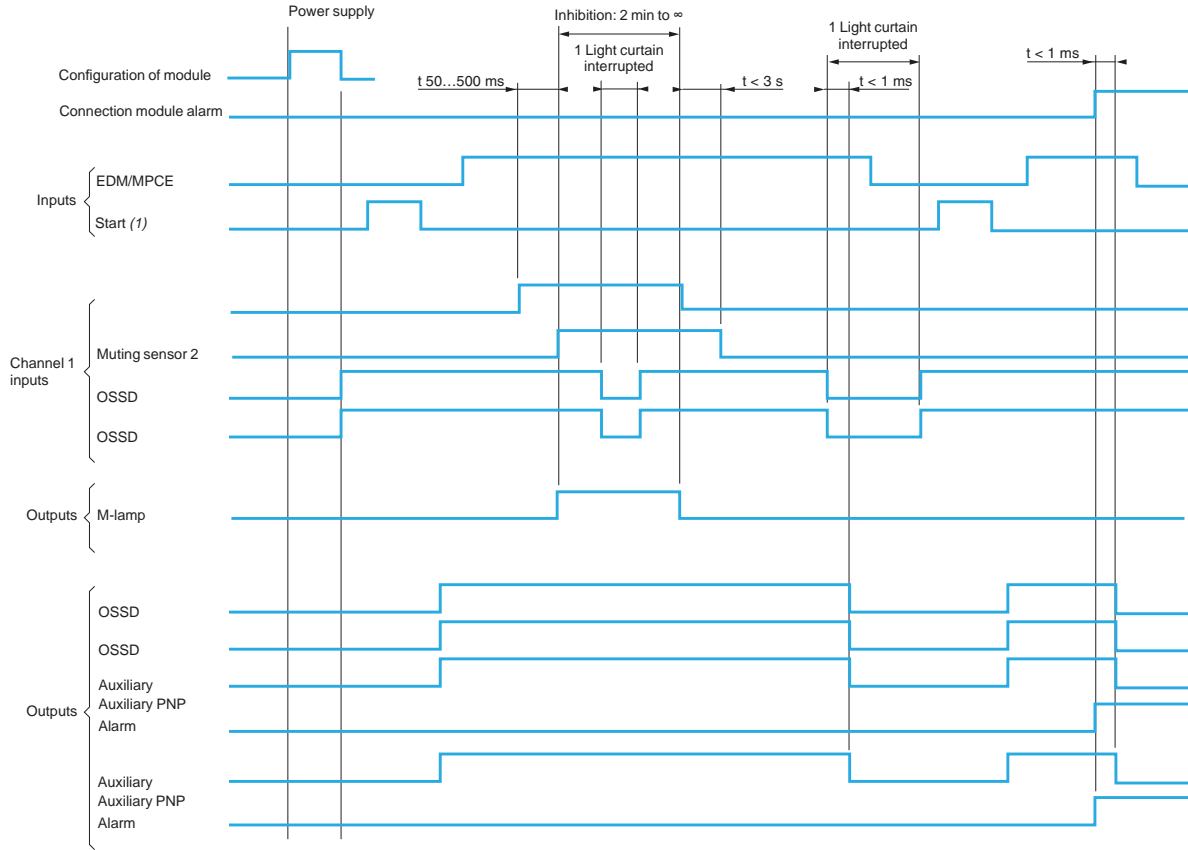

(1) Press the Start button.

Override function

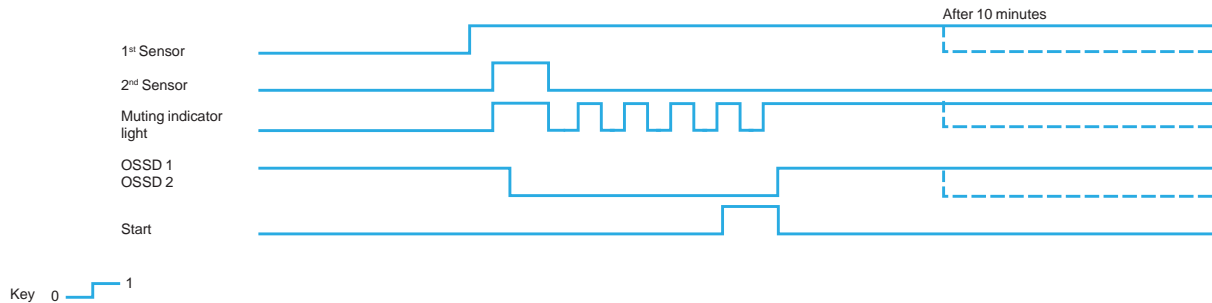

7

Functional diagram of XUSLDM light curtain with connection module XPSLCM1

Start/Restart Interlock mode with 4 sensors

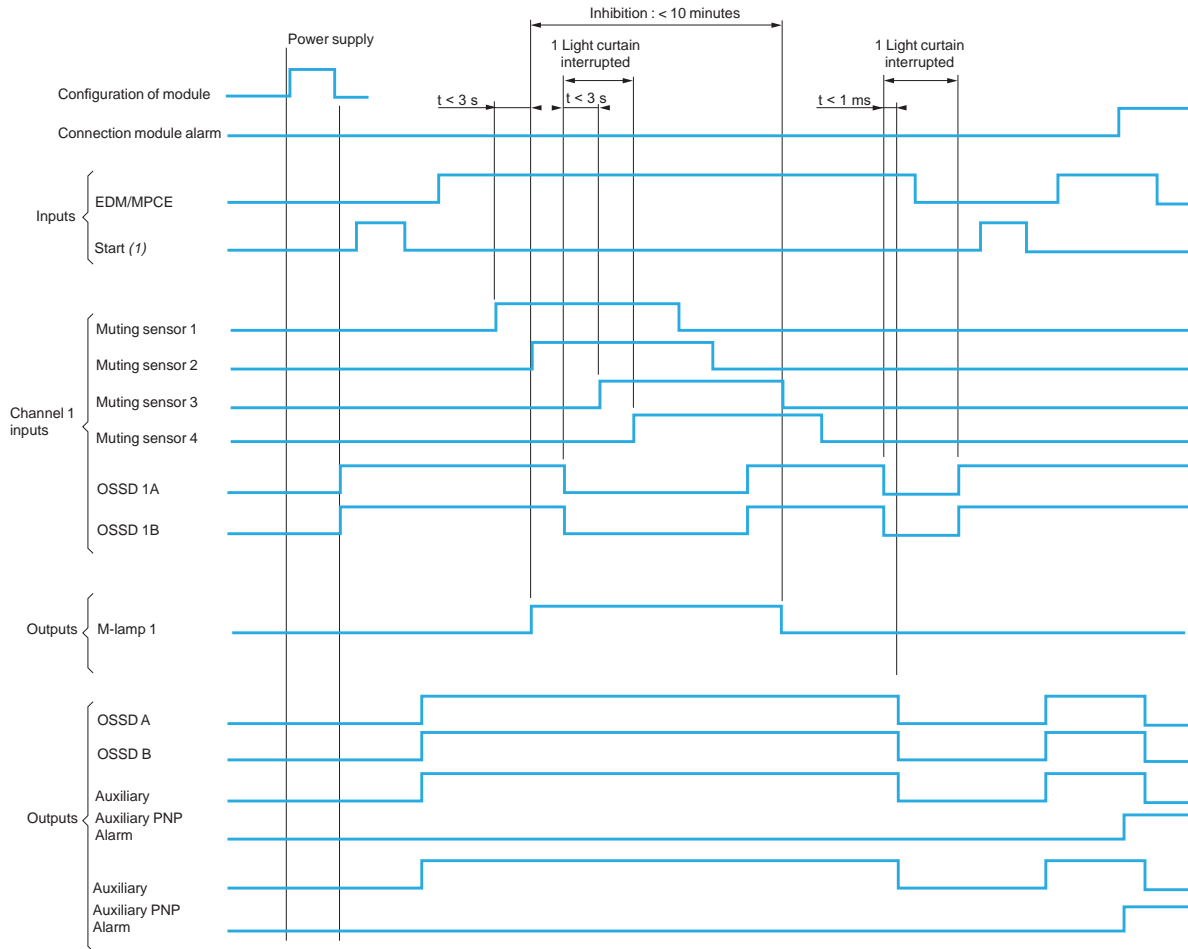

(1) Press the Start button.

Override function

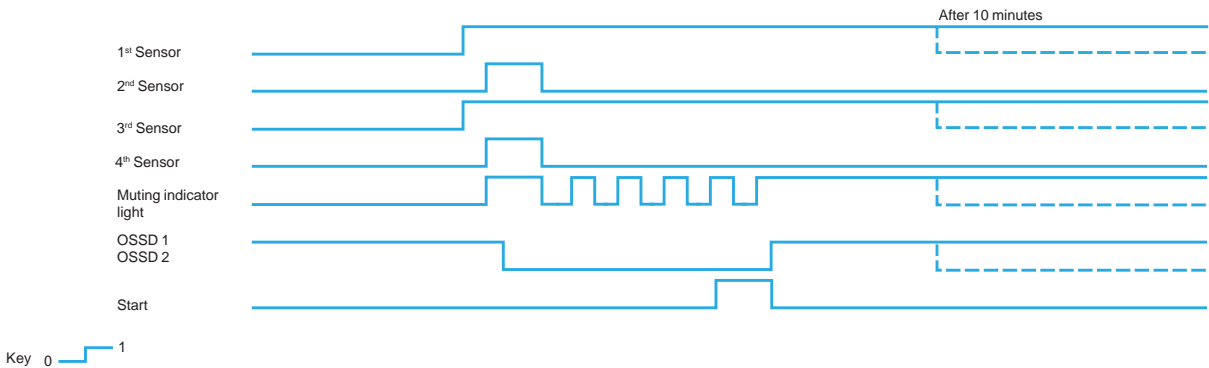

7

Safety detection solutions

Light curtains, type 4

XUSLP compact light curtains with solid-state output

Light curtain type		XUSLP●●●●	
Environmental specifications			
Conformity to standards		ANSI/RIA R15.06, ANSI B11:19-1990, OSHA 1910.217(C), OSHA 1910.212, EN/IEC 61496-1-2 for type 4 ESPE	
Certifications		CE, TUV, UL, CSA	
European directives		Machinery directive 98/37/EC, Work equipment directive 89/655/EEC and EMC directive 89/336 EEC	
Maximum safety level (1)		Category 4 conforming to IEC 61496-1 and 2. PL = e, category 4 conforming to EN/ISO 13849-1 and EN/IEC 61508	
Reliability data B _{10d}		PFH _d = 4.7E ⁻⁹ 1/h conforming to EN/IEC 61508	
Ambient air temperature	Operating	°F (°C)	+32 to +131 (0 to +55)
	Storage	°F (°C)	-13 to +167 (-25 to +75)
Relative humidity		95% maximum, without condensation	
Degree of protection		IP 65 and IP 67	
Shock and vibration resistance		Conforming to IEC 61496-1 Shock resistance: 10 gn, impulse 16 ms, Vibration resistance: 10-55 Hz, amplitude: 0.35 ± 0.05 mm	
Materials		Casing: aluminium with electrostatically applied red (RAL 3000) polyester paint finish; end caps: 20% fiberglass impregnated polycarbonate. Front cover: acrylic.	
Mountings		End brackets (included)	
Optical specifications			
Minimum detection capacity		in. (mm)	11.8, 15.7, 19.7, 23.6 (300, 400, 500, 600) and single beam (Body protection)
Nominal sensing distance (S _n)		ft (m)	2.6 to 65.5 or 2.6 to 229.7 (0.8 to 20 or 0.8 to 70), depending on the configuration; and 2.6 to 26.2 (0.8 to 8) for light curtains with passive receiver
Protected height		Depends on the number of light beams. See the table on page 7/33.	
Effective aperture angle (EAA)		2.5° at 9.8 ft (3 m)	
Light source		GaAlAs LED, 850 nm	
Immunity to ambient light		Conforming to EN/IEC 61496-2	
Electrical specifications			
Response time		ms	< 16 to < 24, depending on the light beam coding selected
Power supply		--- 24 V ± 20% 2 A conforming to EN/IEC 61496 and EN/IEC 60204-1	
	Transmitter	mA	100
	Receiver	A	1.6 (with maximum load)
Maximum current power consumption (no-load)	Transmitter	mA	100
	Receiver	mA	300
Immunity to interference		Conforming to EN/IEC 61496-1	
Safety outputs OSSD (Output Signal Switching Devices)		2 solid-state PNP (N.O.) outputs ≤ 650 mA, --- 24 V (short-circuit protected)	
Auxiliary output		1 solid-state output 100 mA, --- 24 V, PNP	
Monitoring activation of output switching devices (MPCE/EDM)		50 mA, --- 24 V	
Signaling	Transmitter	1 LED (power supply)	
	Receiver	3 LEDs (stop, run, interlock) and a 2-digit display for diagnostics	
Connections (2)	Transmitter	M12, 5-pin, male connector or terminal block	
	Receiver	M12, 8-pin, male connector or terminal block	
Conductor	Transmitter/receiver pre-wired connector	AWG (mm ²)	22 (0.35), tinned wires.
Cable resistance	Transmitter/receiver	Ω	0.016 per ft (0.055 per m) for 22 AWG (0.35 mm ²) wire
Cable lengths		ft (m)	Pre-wired connectors with cable lengths of 16.4, 32.8, 49.2 and 98.4 ft (5, 10, 15, and 30 m) are available separately. The maximum cable length is 394 ft (120 m), depending on the load current and power supply.
Functions			
Functions		Start: - Auto/Manual, manual 1 st cycle - Monitoring of the external switching devices (EDM: External Devices Monitoring) - Test (MTS: Monitoring Test Signal) for XUSLPZ only - Alignment aid by display of each light beam broken - Display of operating modes and alarm by LEDs and 2-digit display Selection of Auto/Manual, relay monitoring, alarm or auxiliary output functions, light beam coding and selection of sensing distance using configuration switches.	
Monitoring the external switching devices (EDM = External Devices Monitoring)		Monitoring of the function (open or closed) as well as the response time of the power components. Parameters can be set using configuration switches.	
Test function		Initiates the stop instruction of the light curtain by opening the contact (simulated intrusion)	
Muting function (inhibition)		Possible with external module XPSLCM1150	
(1) Using an appropriate and correctly connected control system.			
(2) Pre-wired female connectors must be ordered separately. See page 7/31.			

7

Safety detection solutions

Light curtains, type 4

XUSLP compact light curtains with solid-state output, with connector



Transmitter-receiver pairs for body protection (1)

Detection capacity: 11.8, 15.7, 19.7, 23.6 in. (300, 400, 500, 600 mm) and single beam.

Sensing distance: 2.6 to 65.5 ft or 2.6 to 229.7 ft (0.8 to 20 m or 0.8 to 70 m) (depending on the configuration).

■ 2 PNP safety outputs

Detection capacity	Response time			Number of light beams	Auxiliary output	Catalog number (2)	Weight
	Light beam coding						
	A	B	C				
in. (mm)	ms	ms	ms				lb (kg)
–	< 24	< 20	< 16	1	PNP	XUSLPZ1AM	9.92 (4.500)
19.69 (500)	< 24	< 20	< 16	2	PNP	XUSLPZ2A0500M	13.89 (6.300)
23.62 (600)	< 24	< 20	< 16	2	PNP	XUSLPZ2A0600M	14.77 (6.700)
15.75 (400)	< 24	< 20	< 16	3	PNP	XUSLPZ3A0400M	15.87 (7.200)
19.69 (500)	< 24	< 20	< 16	3	PNP	XUSLPZ3A0500M	18.96 (8.600)
11.81 (300)	< 24	< 20	< 16	4	PNP	XUSLPZ4A0300M	18.08 (8.200)
11.81 (300)	< 24	< 20	< 16	5	PNP	XUSLPZ5A0300M	20.94 (9.500)
11.81 (300)	< 24	< 20	< 16	6	PNP	XUSLPZ6A0300M	22.93 (10.400)

(1) Includes 2 sets of 2 brackets with mountings and a user guide with certificate of conformity.

Pre-wired female connectors must be ordered separately. See page 7/31.

(2) To order a receiver only, add the letter **R** to the end of the catalog number for the corresponding transmitter-receiver pair.

Example: XUSLPZ2A0600M becomes **XUSLPZ2A0600MR** for the receiver only.

To order a transmitter only, add the letter **T** to the end of the catalog number for the corresponding transmitter-receiver pair.

Example: XUSLPZ2A0600M becomes **XUSLPZ2A0600MT** for the transmitter only.

Transmitter-receiver pairs for body protection, with passive receiver (1)

Detection capacity: 19.7 and 23.6 in. (500 and 600 mm).

Sensing distance: 2.6 to 26.3 ft (0.8 to 8 m).

■ 2 PNP safety outputs

Detection capacity	Response time			Number of light beams	Auxiliary output	Catalog number (2)	Weight
	Light beam coding						
	A	B	C				
in. (mm)	ms	ms	ms				lb (kg)
19.69 (500)	< 24	< 20	< 16	2	PNP	XUSLPB2A500M	13.89 (6.300)
23.62 (600)	< 24	< 20	< 16	2	PNP	XUSLPB2A600M	14.77 (6.700)

(1) Includes 2 sets of 2 brackets with mountings and a user guide with certificate of conformity.

Pre-wired female connectors must be ordered separately. See page 7/31.

(2) To order a passive receiver, replace the letter **M** with the letter **P** at the end of the catalog number for the corresponding transmitter-receiver pair.

Example: XUSLPB2A500M becomes **XUSLPB2A500P** for the passive receiver.

To order a transmitter only, add the letter **R** to the end of the catalog number for the corresponding transmitter-receiver pair.

Example: XUSLPB2A600M becomes **XUSLPB2A600MR** for the transmitter only.

Other versions

Combining type 4 light curtains with an external module for the Muting function. See page 2/218 of the *Machine Safety Products* catalog, MKTED208051EN-US.

Separate components and accessories: page 7/31



XUSLPB2●●

Principle:
page 7/6

Specifications:
page 7/28

Catalog Numbers:
page 7/29

Dimensions:
page 7/32

Wiring Diagrams:
page 7/34

Safety detection solutions

Light curtains, type 4

XUSLP compact light curtains with solid-state output, with terminal block

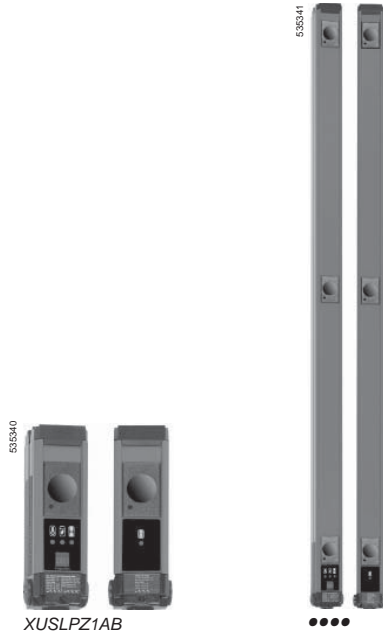

Transmitter-receiver pairs for body protection (1)

Detection capacity: 11.8, 15.7, 19.7, 23.6 in. (300, 400, 500, 600 mm) and single beam.

Sensing distance: 2.6 to 65.5 ft or 2.6 to 229.7 ft (0.8 to 20 m or 0.8 to 70 m) (depending on the configuration).

■ 2 PNP safety outputs

Detection capacity	Response time			Number of light beams	Auxiliary output	Catalog number (2)	Weight
	Light beam coding						
	A	B	C				
–	< 24	< 20	< 16	1	PNP	XUSLPZ1AB	9.92 (4.500)
19.69 (500)	< 24	< 20	< 16	2	PNP	XUSLPZ2A0500B	13.89 (6.300)
23.62 (600)	< 24	< 20	< 16	2	PNP	XUSLPZ2A0600B	14.77 (6.700)
15.75 (400)	< 24	< 20	< 16	3	PNP	XUSLPZ3A0400B	15.87 (7.200)
19.69 (500)	< 24	< 20	< 16	3	PNP	XUSLPZ3A0500B	18.96 (8.600)
11.81 (300)	< 24	< 20	< 16	4	PNP	XUSLPZ4A0300B	18.08 (8.200)
11.81 (300)	< 24	< 20	< 16	5	PNP	XUSLPZ5A0300B	20.94 (9.500)
11.81 (300)	< 24	< 20	< 16	6	PNP	XUSLPZ6A0300B	22.93 (10.400)

(1) Includes 2 sets of 2 brackets with mountings and a user guide with certificate of conformity.

(2) To order a receiver only, add the letter **R** to the end of the catalog number for the corresponding transmitter-receiver pair.

Example: XUSLPZ2A0600B becomes **XUSLPZ2A0600BR** for the receiver only.

To order a transmitter only, add the letter **T** to the end of the catalog number for the corresponding transmitter-receiver pair.

Example: XUSLPZ2A0600B becomes **XUSLPZ2A0600BT** for the transmitter only.

Other versions

Combining type 4 light curtains with an external module for the Muting function. See page 2/218 of the *Machine Safety Products* catalog, MKTED208051EN-US.

Separate components and accessories: page 7/31

Safety detection solutions

Light curtains, type 4

XUSLP accessories for compact light curtains



Separate components

Power supplies, 90° mirror adapters, protective covers, anti-vibration kit, mounting bases

See pages 7/40 to 7/47.

Accessories

Description	Usage	Length m	Catalog number	Weight lb (kg)	
Mountings kit (2 brackets)	For XUSLP light curtains	–	XUSLZ219	0.99 (0.450)	
Pre-wired female connectors	Transmitter type	16.40 (5)	XSZ PCT05	0.77 (0.350)	
		32.81 (10)	XSZ PCT10	1.54 (0.700)	
		49.21 (15)	XSZ PCT15	2.25 (1.020)	
		98.43 (30)	XSZ PCT30	4.45 (2.020)	
	Receiver type	16.40 (5)	XSZ PCR05	0.77 (0.350)	
		32.81 (10)	XSZ PCR10	1.54 (0.700)	
		49.21 (15)	XSZ PCR15	2.25 (1.020)	
		98.43 (30)	XSZ PCR30	4.45 (2.020)	
		Sliding nuts for side mounting (4 nuts)	–	XUSLZ320	0.99 (0.450)
		User guide on CD-ROM	All light curtain types	–	XUSLZ450
Arc suppressor (pair)	All light curtain types	–	XUSLZ500	0.04 (0.020)	

Light curtains

XUSLP●●●

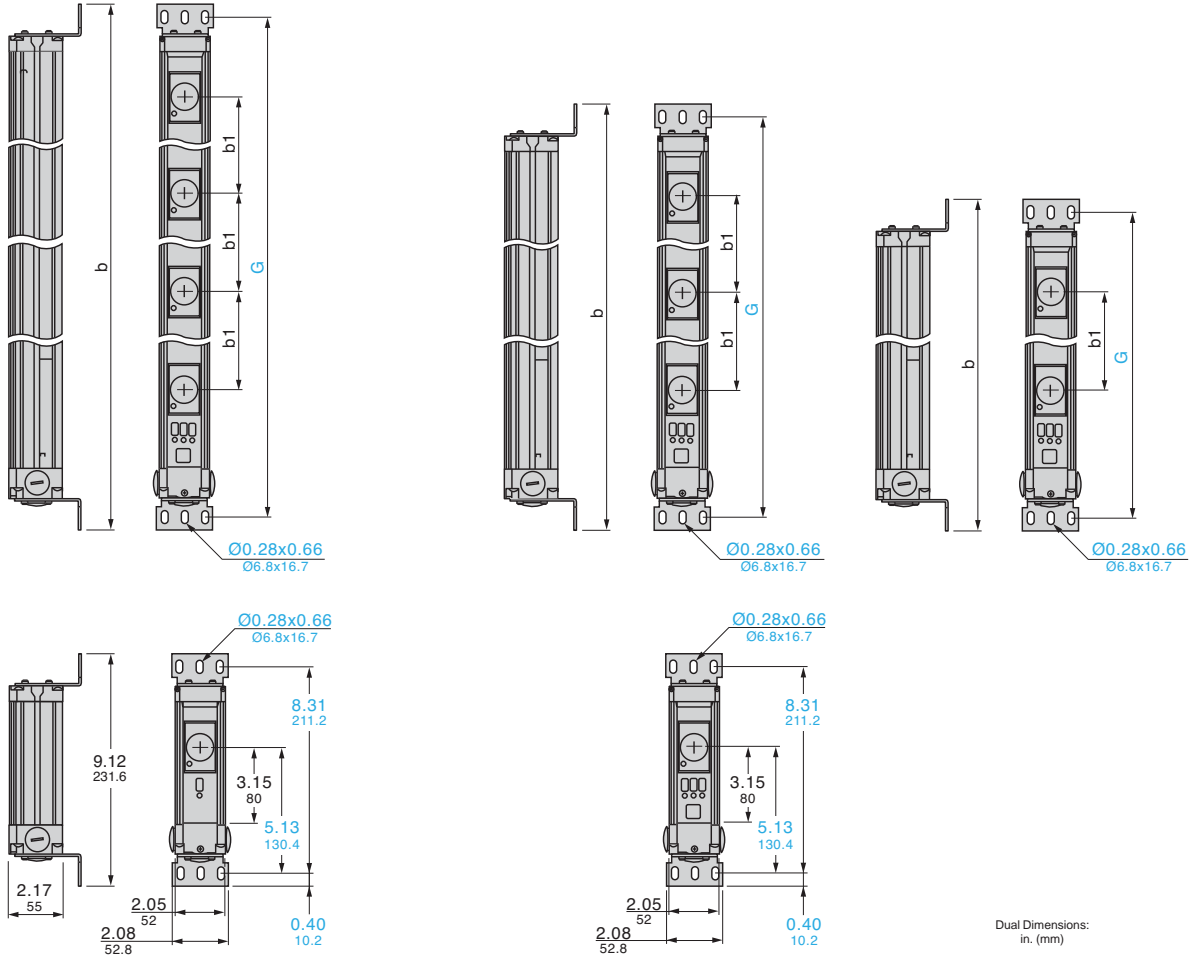

7

XUS	b in. (mm)	b1 in. (mm)	G in. (mm)
LPZ1A●	9.12 (231.6)	—	8.69 (220.7)
LPZ2A0500●	28.80 (731.6)	19.69 (500)	28.37 (720.7)
LPZ2A0600●	32.74 (831.6)	23.62 (600)	32.31 (820.7)
LPZ3A0400●	40.61 (1031.6)	15.75 (400)	40.19 (1020.7)
LPZ3A0500●	48.49 (1231.6)	19.69 (500)	48.06 (1220.7)
LPZ4A0300●	44.93 (1141.1)	11.81 (300)	44.12 (1120.7)
LPZ5A0300●	56.36 (1431.6)	11.81 (300)	55.56 (1411.2)
LPZ6A0300●	68.17 (1731.6)	11.81 (300)	67.37 (1711.2)

Safety detection solutions

Light curtains, type 4

XUSLP compact light curtains with solid-state output

Light curtains

XUSLP●●●

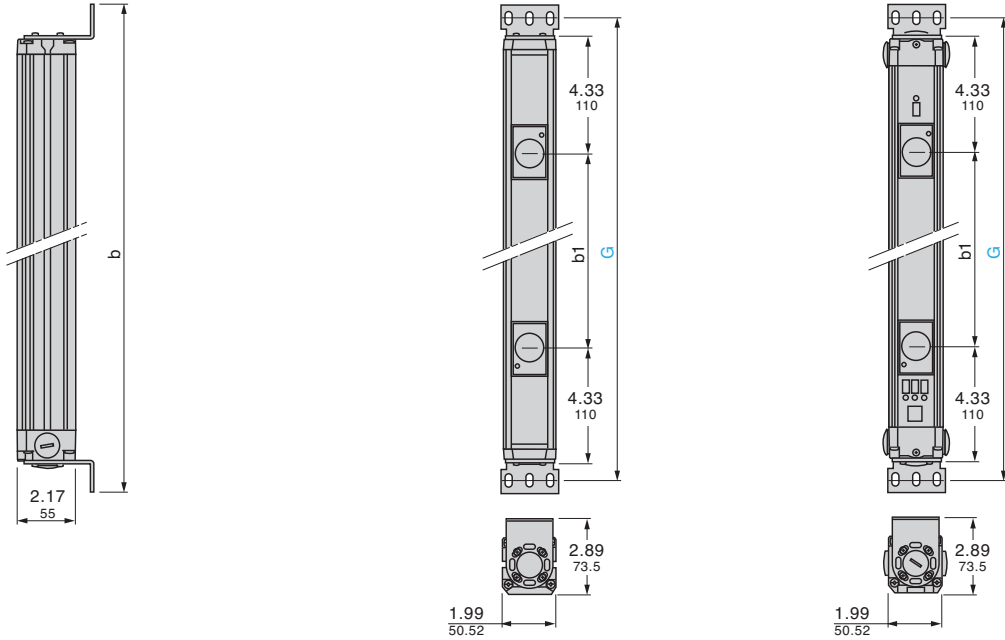

Dual Dimensions:
in. (mm)

XUS	b in. (mm)	b1 in. (mm)	G in. (mm)
LPB2A500M	30.75 (781.1)	19.69 (500)	29.95 (760.7)
LPB2A600M	34.69 (881.1)	23.62 (600)	33.89 (860.7)

Direct connection with XUSLP●●●

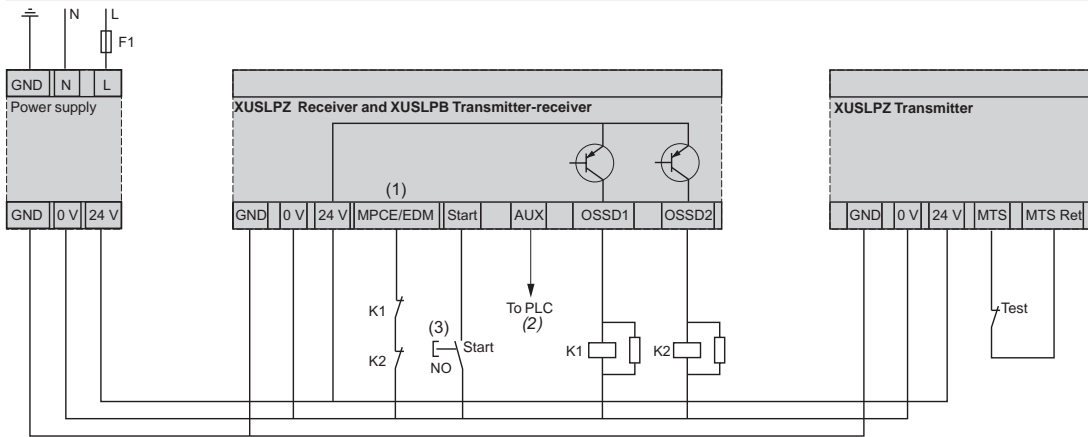

(1) For testing prior to installation, you can select MPCE/EDM OFF (factory default setting). In that case, the MPCE/EDM line must be connected to the 0 V line of the system.

(2) The auxiliary output connects to a PLC (optional).

(3) If remote start is not used, connect the start line to the 0 V line.

Connection via a Preventa® XPSAFL module

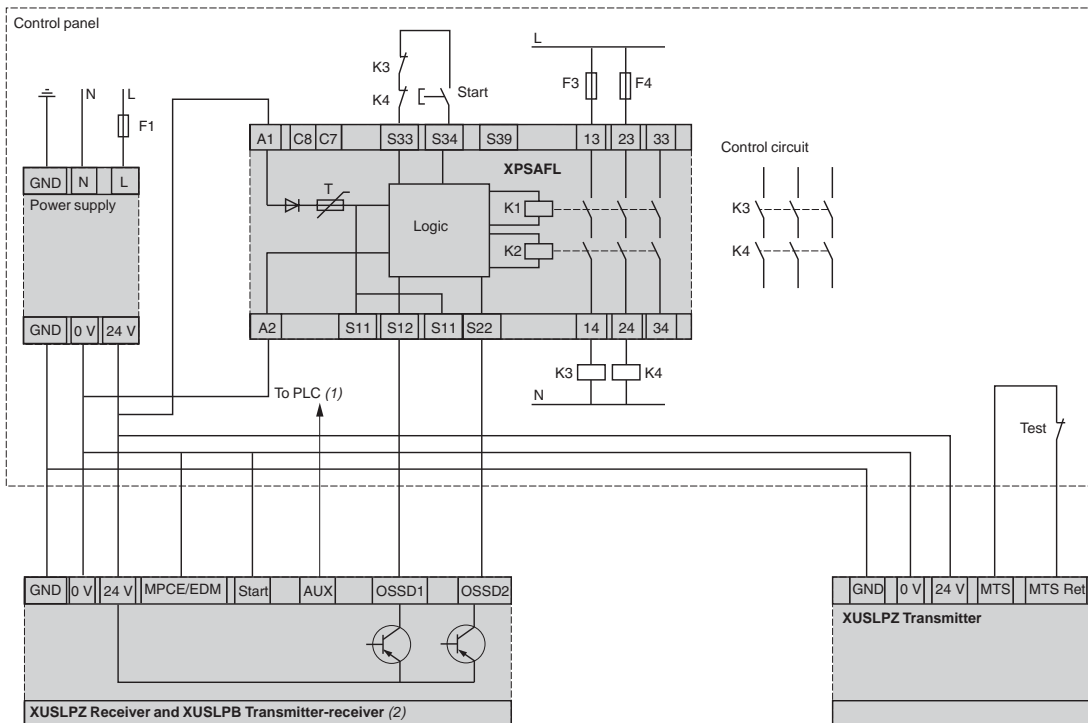

(1) The auxiliary output connects to a PLC (optional).

(2) The light curtain must be configured with MPCE/EDM OFF and with automatic start.

Safety detection solutions

Light curtains, type 4

XUSLP compact light curtains with solid-state output

XUSLPZ/LPB

Transmitter

Pre-wired connector of transmitter (XUSLPZ)

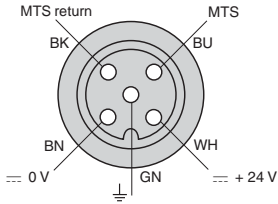

Transmitter status indicator

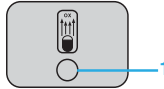

1 Yellow LED

Configuration indicator XUSLPZ

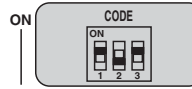

Configuration indicator XUSLPB



Receiver

Pre-wired connector of receiver (XUSLPZ) and pre-wired connector of transmitter-receiver (XUSLPB)

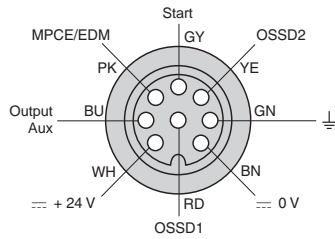

Receiver status indicator

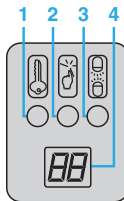

- 1 Interlock or Alarm yellow LED
- 2 Machine stop red LED
- 3 Machine run green LED
- 4 2-digit display

Configuration indicator XUSLPZ and XUSLPB

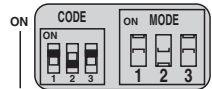

Connection to terminal block

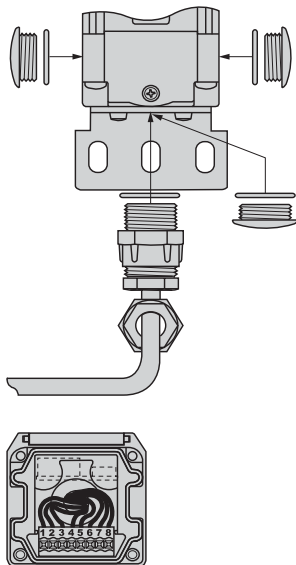

Connection to M12 connector

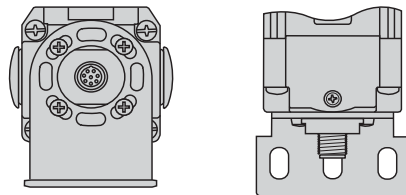

Safety detection solutions

Light curtains, type 2

XUSLN slim, compact light curtains with solid-state output

Light curtain type		XUSLNG●●●● 1.18 in. (30 mm)	
Environmental specifications			
Conformity to standards		IEC 61496-1 and IEC 61496-2 (Type 2 ESPE)	
Certifications		CE, TUV, UL, CSA	
European directives		Machinery directive 98/37/EC, Work equipment directive 89/655/EEC and EMC directive 89/336 EEC	
Maximum safety level (1)		Category 4 conforming to IEC 61496-1 and 2. PL = e, category 4 conforming to EN/ISO 13849-1 and EN/IEC 61508	
Reliability data B _{10d}		PFH _a = 4.9E ⁻⁶ 1/h conforming to EN/IEC 61508	
Ambient air temperature	Operating	°F (°C)	+32 to +131 (0 to +55)
	Storage	°F (°C)	-13 to +167 (-25 to +75)
Relative humidity		95% maximum, without condensation	
Degree of protection		IP 65	
Shock and vibration resistance		Conforming to IEC 61496-1 Shock resistance: 10 gn, impulse 16 ms, Vibration resistance: 10–55 Hz, amplitude: 0.35 ± 0.05 mm	
Materials			
Mountings		Casing: aluminium with electrostatically applied red (RAL 3000) polyester paint finish; end caps: 30% fiberglass impregnated nylon; front cover: acrylic. End brackets (included)	
Optical specifications			
Minimum detection capacity		in. (mm)	1.18 (30) (Hand)
Nominal sensing distance (Sn)		ft (m)	1–49.3 (0.3–15)
Protected height		in. (mm)	5.29–57.87 in. (150–1500 mm)
Effective aperture angle (EAA)		5° at 3 m conforming to IEC 61496-1 and IEC 61496-2 (Type 2 ESPE)	
Light source		GaAlAs LED, 880 nm	
Immunity to ambient light		Conforming to IEC/EN 61496-2	
Electrical specifications			
Response time		ms	14–24
Power supply		⎓ 24 V ± 20% 2 A conforming to IEC 61496 and IEC 60204-1 (-10% using the EDM function)	
	Transmitter	mA	50
	Receiver	A	1.09 (with maximum load)
Maximum current power consumption (no-load)	Transmitter	mA	50
	Receiver	mA	90
Immunity to interference		Conforming to EN 61496-1 and EN 61496-2	
Safety outputs OSSD (output signal switching devices)		2 solid-state PNP (N.O.) outputs ≤ 500 mA, ⎓ 24 V (short-circuit protection)	
Signaling	Transmitter	2 LEDs (power supply and diagnostic)	
	Receiver	4 LEDs (stop, run, top alignment and bottom alignment)	
Connections (2)	Transmitter	M12, 4-pin, male connector	
	Receiver	M12, 5-pin, male connector	
Pre-wired connectors		AWG (mm ²)	22 (0.25) Tinned wires.
Cable resistance		Ω	0.028 Ω/ft (0.093 Ω/m) for 22 AWG (0.25 mm ²) wire
Cable lengths		ft (m)	Pre-wired connectors with cable lengths of 9.84, 32.81, and 98.43 ft (3, 10, and 30 m) are available separately. The maximum cable length is 164 ft (50 m), depending on the load current and power supply.
Functions			
Functions		<ul style="list-style-type: none"> ■ Start: □ Automatic: model XUSLNG5C □ Manual: model XUSLNG5D ■ Alignment aid using 2 LEDs ■ LED display of operating modes ■ Monitoring of the external switching devices EDM/MPCE 	
Muting function (inhibition)		Possible with external module XPSLCM1150	

(1) Using an appropriate and correctly connected control system.
(2) Pre-wired female connectors must be ordered separately. See page 7/37.

7

Safety detection solutions

Light curtains, type 2

XUSLNG slim, compact light curtains with solid-state output



Transmitter-receiver system for hand protection (1)

Detection capacity: 1.18 in. (30 mm). Sensing distance: 0.89 to 49.21 ft (0.3 to 15 m).

■ 2 PNP safety outputs—Automatic start

Protected height	Response time	Number of light beams	Alarm output	Catalog number (2)	Weight
in. (mm)	ms				lb (kg)
5.91 (150)	14	7	PNP	XUSLNG5C0150	5.95 (2.700)
11.81 (300)	15	14	PNP	XUSLNG5C0300	6.39 (2.900)
17.72 (450)	16	21	PNP	XUSLNG5C0450	7.05 (3.200)
23.62 (600)	17	28	PNP	XUSLNG5C0600	7.50 (3.400)
29.53 (750)	18	35	PNP	XUSLNG5C0750	7.94 (3.600)
35.43 (900)	19	42	PNP	XUSLNG5C0900	8.60 (3.900)
41.34 (1050)	20	49	PNP	XUSLNG5C1050	9.04 (4.100)
47.24 (1200)	21	56	PNP	XUSLNG5C1200	9.48 (4.300)
53.15 (1350)	22	63	PNP	XUSLNG5C1350	9.92 (4.500)
59.06 (1500)	23	70	PNP	XUSLNG5C1500	10.58 (4.800)

■ 2 PNP safety outputs—Manual start

Protected height	Response time	Number of light beams	Alarm output	Catalog number (2)	Weight
in. (mm)	ms				lb (kg)
5.91 (150)	14	7	PNP	XUSLNG5D0150	5.95 (2.700)
11.81 (300)	15	14	PNP	XUSLNG5D0300	6.39 (2.900)
17.72 (450)	16	21	PNP	XUSLNG5D0450	7.05 (3.200)
23.62 (600)	17	28	PNP	XUSLNG5D0600	7.50 (3.400)
29.53 (750)	18	35	PNP	XUSLNG5D0750	7.94 (3.600)
35.43 (900)	19	42	PNP	XUSLNG5D0900	8.60 (3.900)
41.34 (1050)	20	49	PNP	XUSLNG5D1050	9.04 (4.100)
47.24 (1200)	21	56	PNP	XUSLNG5D1200	9.48 (4.300)
53.15 (1350)	22	63	PNP	XUSLNG5D1350	9.92 (4.500)
59.06 (1500)	23	70	PNP	XUSLNG5D1500	10.58 (4.800)

(1) Includes a test rod, 2 sets of 2 brackets with mountings, and a user guide with certificate of conformity and 1 arc suppressor set.

Pre-wired female connectors must be ordered separately. See below.

(2) To order a transmitter only, replace the letter C or D with E and add the letter T to the end of the catalog number for the corresponding transmitter-receiver pair.

Example: XUSLNG5C0150 becomes XUSLNG5E0150T for the transmitter only.

To order a receiver only, add the letter R to the end of the catalog number for the corresponding transmitter-receiver pair.

Example: XUSLNG5C0150 becomes XUSLNG5C0150R for the receiver only.

Other versions

Combining type 2 light curtains with external module for Muting function and monitoring 2–4 light curtains. See page 2/218 of the Machine Safety Products catalog, MKTED208051EN-US.

Accessories

Description	For use with	Length ft (m)	Catalog number	Weight oz (kg)
Mounting kit (2 brackets)	XUSLNG light curtains	–	XUSLZ218	0.99 (0.450)
Pre-wired female connectors	Transmitter type	9.84 (3)	XSZ NCT03	1.50 (0.680)
		32.81 (10)	XSZ NCT10	2.01 (0.910)
		98.43 (30)	XSZ NCT30	3.00 (1.360)
	Receiver type	9.84 (3)	XSZ NCR03	1.50 (0.680)
32.81 (10)		XSZ NCR10	2.01 (0.910)	
98.43 (30)		XSZ NCR30	3.00 (1.360)	
Arc suppressor (pair)	All types of light curtains	–	XUSLZ500	0.04 (0.020)
User guide on CD-ROM	All types of light curtains and accessories	–	XUSLZ450	0.04 (0.020)

Separate components

Power supplies, 90° mirror adapters, anti-vibration kit and mounting bases

See pages 7/40 to 7/47.



Dimensions

Slim, compact light curtains

XUSLN●●●

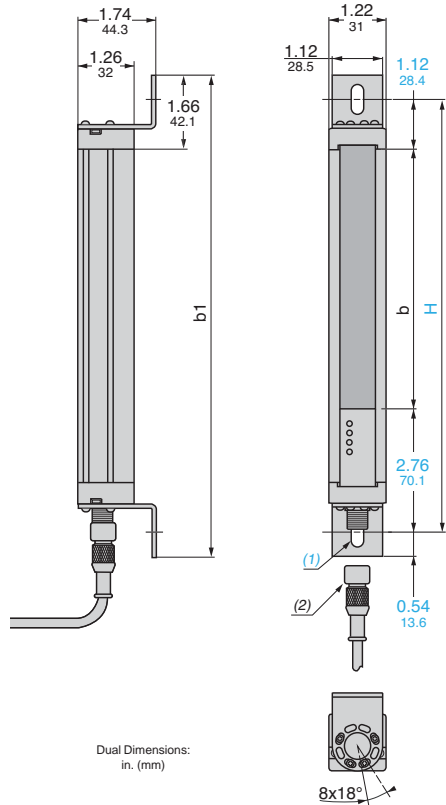

XUS	b in. (mm)	b1 in. (mm)	H in. (mm)	Protected height in. (mm)
LN●●●0150	5.79 (147)	10.71 (272)	9.67 (245.6)	5.91 (150)
LN●●●0300	11.57 (294)	16.50 (419)	15.46 (392.6)	11.81 (300)
LN●●●0450	17.36 (441)	22.28 (566)	21.24 (539.5)	17.72 (450)
LN●●●0600	23.15 (588)	28.07 (713)	27.03 (686.6)	23.62 (600)
LN●●●0750	28.94 (735)	33.86 (860)	32.82 (833.6)	29.53 (750)
LN●●●0900	34.72 (882)	39.65 (1007)	38.61 (980.6)	35.43 (900)
LN●●●1050	40.51 (1029)	45.43 (1154)	44.39 (1127.6)	41.34 (1050)
LN●●●1200	46.30 (1176)	51.22 (1301)	50.18 (1274.6)	47.24 (1200)
LN●●●1350	52.09 (1323)	57.01 (1448)	55.97 (1421.6)	53.15 (1350)
LN●●●1500	57.87 (1470)	62.80 (1595)	61.76 (1568.6)	59.06 (1500)

(1) 1 elongated hole $\varnothing 0.27 \times 0.66$ in. ($\varnothing 6.75 \times 16.75$ mm.)
(2) M12 male connector.

Connections

Transmitter

Pre-wired connector of transmitter XSZ NCT

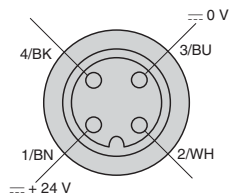

Transmitter status indicator

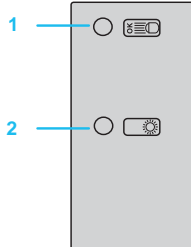

- 1 Interlock or Alarm yellow LED
- 2 Switch-on/Machine run green LED

Receiver

Pre-wired connector of receiver XSZ NCR

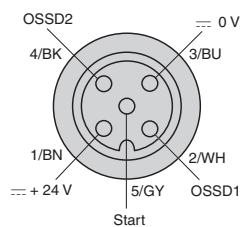

Receiver status indicator

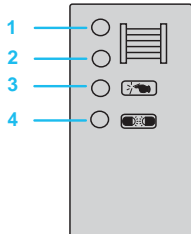

- 1 Top alignment yellow LED
- 2 Bottom alignment yellow LED
- 3 Stop red LED
- 4 Run green LED

Principle:
page 7/6

Specifications:
page 7/36

Catalog Numbers:
page 7/37

Dimensions:
page 7/38

Wiring Diagrams:
page 7/39

Wiring diagrams (continued)

Direct connection with XUSLNG5D●●●

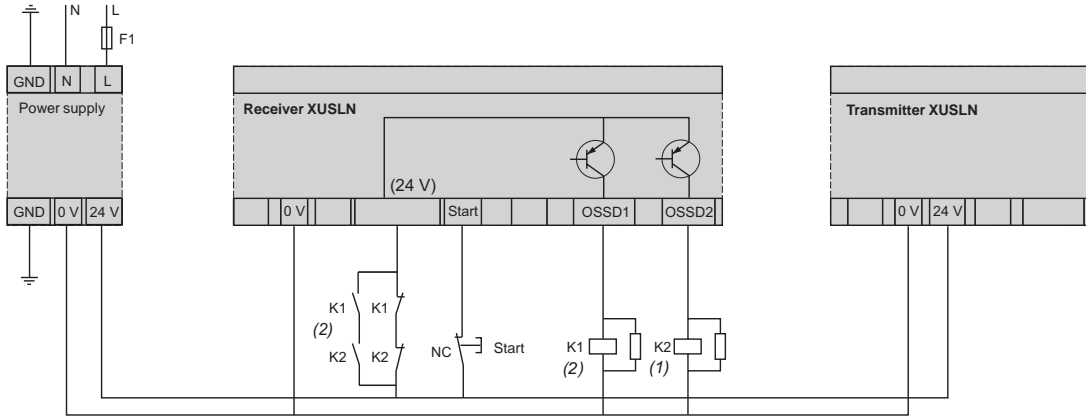

(1) The K1 and K2 coils must be protected using the arc suppressors included in the documentation kit.

(2) For the EDM function, contactors LC1D●●BD and control relays CAD●●BD, CA4KN●●BW3, and CA3KN●●BD are recommended

Connection of XUSLNL5C●●● light curtain via a Preventa® XPSAFL module

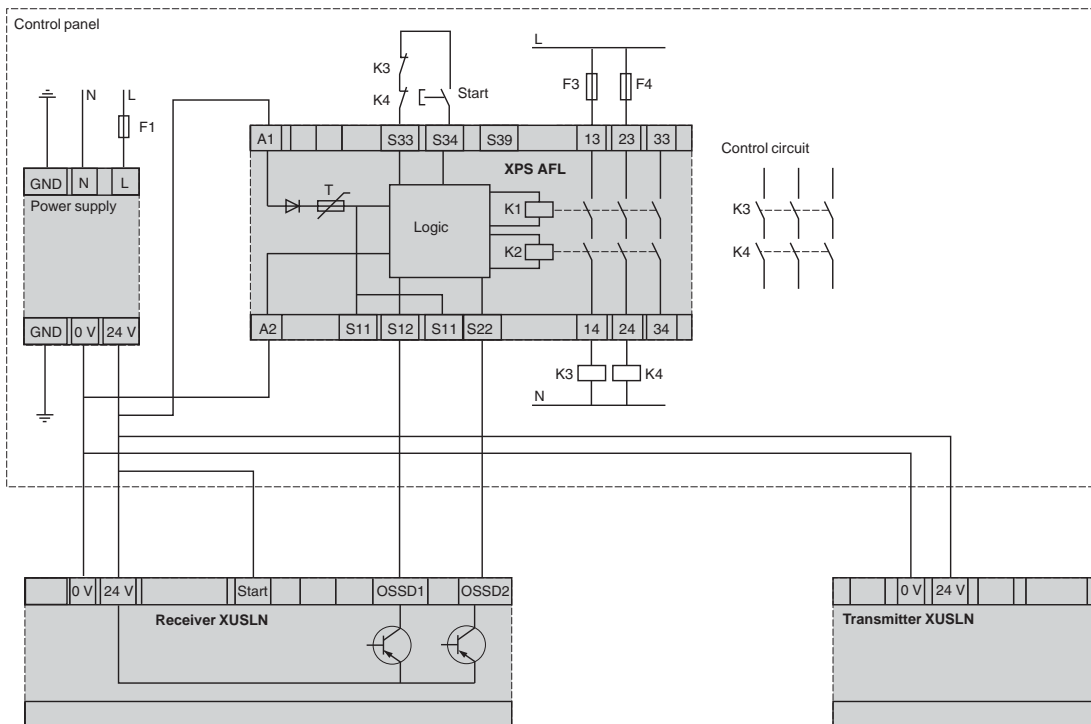

90° mirror adapter for light curtains

Glass mirror (0.88 Sn) (1)

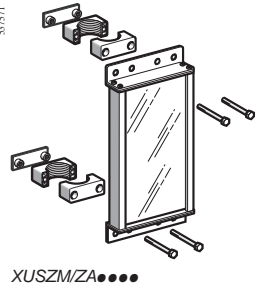

Description	For use with light curtains			Height (2) in. (mm)	Catalog number	Weight lb (kg)
	XUSLB/LDM	XUSLP	XUSLN			
90° mirror adapter with rotatable mounting	—	XUSLPZ1A●	—	5.5 (140)	XUSZM0102	2.3 (1.040)
	—	—	—	7.5 (191)	XUSZM0152	2.9 (1.300)
	XUSLB/LDM0280	—	XUSLN●●●0150	13.5 (343)	XUSZM0305	4.2 (1.900)
	XUSLB/LDM0320	—	XUSLN●●●0300	19.5 (495)	XUSZM0457	5.5 (2.500)
	XUSLB/LDM0360	—	—	—	—	—
	XUSLB/LDM0440	—	XUSLN●●●0450	21.5 (546)	XUSZM0508	6.2 (2.800)
	XUSLB/LDM0520	XUSLP●2A500●	—	25.5 (648)	XUSZM0610	7.1 (3.200)
	XUSLB/LDM0600/0680	XUSLP●2A0600●	XUSLN●●●0600	29.5 (749)	XUSZM0711	8.2 (3.700)
	XUSLB/LDM0720	—	—	31.5 (800)	XUSZM0762	8.4 (3.800)
	XUSLB/LDM0760	—	XUSLN●●●0750	33.5 (851)	XUSZM0813	8.8 (4.000)
	XUSLB/LDM0880	XUSLPZ3A0400●	—	37.5 (953)	XUSZM0914	9.9 (4.500)
	XUSLB/LDM0920/0960	—	XUSLN●●●0900	41.5 (1054)	XUSZM1016	11 (5.000)
	XUSLB/LDM1040	XUSLPZ3A0500●	—	43.5 (1105)	XUSZM1067	11.5 (5.200)
	XUSLB/LDM1120	XUSLPZ4A0300●	XUSLN●●●1050	49.5 (1257)	XUSZM1219	13 (5.900)
	XUSLB/LDM1200	XUSLPZ5A0300●	XUSLN●●●1200	53.5 (1359)	XUSZM1321	13.9 (6.300)
	XUSLB/LDM1360	—	XUSLN●●●1350	55.5 (1410)	XUSZM1372	14.3 (6.500)
	XUSLB/LDM1400	—	—	57.5 (1461)	XUSZM1422	14.8 (6.700)
	XUSLB/LDM1520	—	XUSLN●●●1500	61.5 (1562)	XUSZM1524	15.9 (7.200)
	XUSLB/LDM1560	XUSLPZ6A0300●	—	65.5 (1664)	XUSZM1626	16.8 (7.600)
	XUSLB/LDM1640/1720	—	—	73.5 (1867)	XUSZM1830	18.7 (8.500)
XUSLB/LDM1800	—	—	73.5 (1867)	XUSZM1830	18.7 (8.500)	
XUSLB/LDM1920/2120	—	—	85.5 (2172)	XUSZM2134	21.6 (9.800)	

Stainless steel mirror (0.82 Sn) (1)

Description	For use with light curtains			Height (2) in. (mm)	Catalog number	Weight lb (kg)
	XUSLB/LDM	XUSLP	XUSLN			
90° mirror adapter with rotatable mounting	—	XUSLPZ1A●	—	5.5 (140)	XUSZA0102	2.4 (1.090)
	—	—	—	7.5 (191)	XUSZA0152	2.9 (1.300)
	XUSLB/LDM0280	—	XUSLN●●●0150	13.5 (343)	XUSZA0305	4.4 (2.000)
	XUSLB/LDM0320	—	XUSLN●●●0300	19.5 (495)	XUSZA0457	6 (2.700)
	XUSLB/LDM0360	—	—	—	—	—
	XUSLB/LDM0440	—	XUSLN●●●0450	21.5 (546)	XUSZA0508	6.6 (3.000)
	XUSLB/LDM0520	XUSLP●2A500●	—	25.5 (648)	XUSZA0610	7.7 (3.500)
	XUSLB/LDM0600/0680	XUSLP●2A0600●	XUSLN●●●0600	29.5 (749)	XUSZA0711	8.6 (3.900)
	XUSLB/LDM0720	—	—	31.5 (800)	XUSZA0762	9.3 (4.200)
	XUSLB/LDM0760	—	XUSLN●●●0750	33.5 (851)	XUSZA0813	9.7 (4.400)
	XUSLB/LDM0880	XUSLPZ3A0400●	—	37.5 (953)	XUSZA0914	9.9 (4.500)
	XUSLB/LDM0920/0960	—	XUSLN●●●0900	41.5 (1054)	XUSZA1016	11.9 (5.400)
	XUSLB/LDM1040	XUSLPZ3A0500●	—	43.5 (1105)	XUSZA1067	12.3 (5.600)
	XUSLB/LDM1120	XUSLPZ4A0300●	XUSLN●●●1050	49.5 (1257)	XUSZA1219	14.1 (6.400)
	XUSLB/LDM1200	XUSLPZ5A0300●	XUSLN●●●1200	53.5 (1359)	XUSZA1321	15 (6.800)
	XUSLB/LDM1360	—	XUSLN●●●1350	55.5 (1410)	XUSZA1372	15.4 (7.000)
	XUSLB/LDM1400	—	—	57.5 (1461)	XUSZA1422	16.1 (7.300)
	XUSLB/LDM1520	—	XUSLN●●●1500	61.5 (1562)	XUSZA1524	17.2 (7.800)
	XUSLB/LDM1560	XUSLPZ6A0300●	—	65.5 (1664)	XUSZA1626	18.3 (8.300)
	XUSLB/LDM1640/1720	—	—	73.5 (1867)	XUSZA1830	20.3 (9.200)
XUSLB/LDM1800	—	—	73.5 (1867)	XUSZA1830	20.3 (9.200)	
XUSLB/LDM1920/2120	—	—	85.5 (2172)	XUSZA2134	23.4 (10.600)	

(1) Sensing distance reduction coefficient must be taken into account for each 90° mirror adapter used.

(2) Usable reflective height.

Accessories

Description	Usage	Catalog number	Weight lb (kg)
Laser alignment tool	All light curtain types	XUSLAT1	0.75 (0.340)



ABL8RPS24050

Power supplies for XUSL● light curtains

Input voltage	Secondary		Reset	Conforming to standard EN 61000-3-2	Catalog number	Weight lb (kg)	
	Output voltage	Nominal power					Nominal current
Single phase (N-L1) or 2-phase (L1-L2) connection							
100–120 / 200–500 V~ –15 %, +10 % 50/60 Hz	24–28.8	72 W	3 A	Auto/manual	Yes	ABL8RPS24030	0.7 (0.300)
	V~	120 W	5 A	Auto/manual	Yes	ABL8RPS24050	1.5 (0.700)
		240 W	10 A	Auto/manual	Yes	ABL8RPS24100	2.2 (1.000)

Protective covers for light curtains XUSLB/XUSLDM/XUSLP		XUSZWS●●●●	
Environmental specifications			
Air temperature	Operating	°F (°C)	32 to +131 (0 to +55)
	Storage	°F (°C)	-13 to +158 (-25 to +70)
Material			polycarbonate
Sensing distance (Sn) reduction coefficient			0.91 (1)
Environmental chemicals			
Chemical resistance	Acids, aliphatic hydrocarbons		Resistant
	Alcohols, Alkalis		Limited resistance
	Detergents and cleaners		
	Greases and oils		
	Silicone oils and greases not containing alkaline products		
	Amines		Not resistant
	Aromatic hydrocarbons		
	Detergents and cleaners containing alkaline		
	Esters		
	Halogenated hydrocarbons		
	Ketones		
	Silicone oils and greases containing alkaline products		

Catalog numbers of protective covers

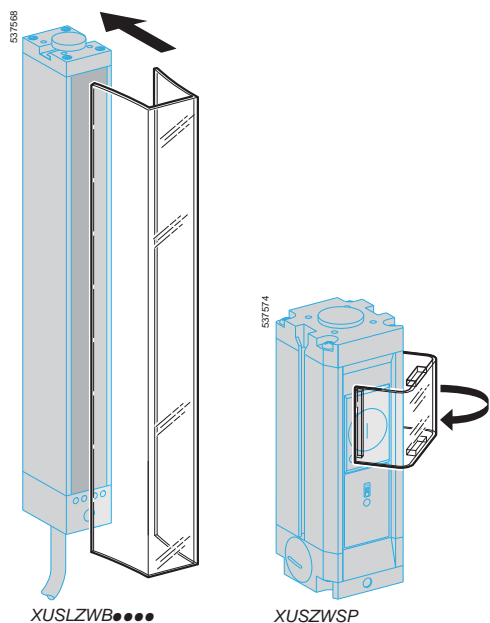

Description	For use with	Height in. (mm)	Catalog number	Weight lb (kg)
Polycarbonate protective covers for transmitter-receiver pair (0.91 Sn) (1) (Sold in sets of 2)	XUSLB/DM280	12.2 (310)	XUSLZWB0280	0.6 (0.282)
	XUSLB/DM320	13.8 (350)	XUSLZWB0320	0.7 (0.318)
	XUSLB/DM360	15.4 (390)	XUSLZWB0360	0.8 (0.354)
	XUSLB/DM440	18.5 (470)	XUSLZWB0440	0.9 (0.426)
	XUSLB/DM520	21.7 (550)	XUSLZWB0520	1.1 (0.497)
	XUSLB/DM600	24.8 (630)	XUSLZWB0600	1.3 (0.569)
	XUSLB/DM680	28 (710)	XUSLZWB0680	1.4 (0.641)
	XUSLB/DM720	29.5 (750)	XUSLZWB0720	1.5 (0.677)
	XUSLB/DM760	31.1 (790)	XUSLZWB0760	1.6 (0.713)
	XUSLB/DM880	35.8 (910)	XUSLZWB0880	1.8 (0.821)
	XUSLB/DM920	37.4 (950)	XUSLZWB0920	1.9 (0.857)
	XUSLB/DM960	39 (990)	XUSLZWB0960	2.0 (0.893)
	XUSLB/DM1040	42.1 (1070)	XUSLZWB1040	2.1 (0.965)
	XUSLB/DM1120	45.3 (1150)	XUSLZWB1120	2.3 (1.037)
	XUSLB/DM1200	48.4 (1230)	XUSLZWB1200	2.4 (1.108)
	XUSLB/DM1360	54.7 (1390)	XUSLZWB1360	2.8 (1.252)
	XUSLB/DM1400	56.3 (1430)	XUSLZWB1400	2.8 (1.288)
XUSLB/DM1520	61 (1550)	XUSLZWB1520	3.1 (1.396)	
XUSLB/DM1560	62.6 (1590)	XUSLZWB1560	3.2 (1.432)	
XUSLB/DM1640	65.7 (1670)	XUSLZWB1640	3.3 (1.504)	
XUSLB/DM1720	68.9 (1750)	XUSLZWB1720	3.5 (1.576)	
XUSLB/DM1800	72 (1830)	XUSLZWB1800	3.6 (1.648)	
XUSLB/DM1920	76.8 (1950)	XUSLZWB1920	3.9 (1.756)	
XUSLB/DM2120	84.6 (2150)	XUSLZWB2120	4.3 (1.935)	

Description	For use with	Height in. (mm)	Catalog number	Weight lb (kg)
Polycarbonate protective covers for single beam device (0.91 Sn) (1) (Sold in sets of 2)	XUSLP	2.5 (62.48)	XUSZWSP	2.2 (0.100)

(1) Sensing distance reduction coefficient must be taken into account for each pair of polycarbonate protective covers used.



Anti-vibration kit

Selection according to weight and application

Weight classes

Light curtain type	Height in. (mm)	Weight class				Type of mirror adapters	Height in. (mm)	Weight class			
		1	2	3	4			1	2	3	4
XUSLN	5.9–23.6 (150–600)	•				XUSZM (1)	4 (102)	•			
	29.5–59.1 (750–1500)		•				12–18 (305–457)		•		
XUSLB/LDMQ/LDSQ/XUSLTQ	11–40.9 (280–1040)		•			XUSZA	20–28 (508–711)			•	
	44.1–53.5 (1120–1360)			•			32–40 (813–1016)				•
XUSLBR/LDMY/LDSY/XUSLTR/Y	12.6–40.9 (320–1040)		•			XUSZA	4 (102)	•			
	44.1–83.5 (1120–2120)			•			12–42 (305–1067)		•		
XUSLPZ1A	–			•			48–64 (1219–1626)			•	
XUSLPZ2A0500 et XUSLPZ2A0600	–			•			72–84 (1830–2134)				•
XUSLPZ3A0400	–			•							
XUSLPZ3A0500	–				•						
XUSLPZ4A0300	–				•						
XUSLPZ5A0300 et XUSLPZ6A0300	–				•						
XUSLPB2A500 et XUSLPB2A600	–				•						

(1) Use of the anti-vibration kit is not recommended for mirror adapters greater than 40 in. (1016 mm) in height.

Applications

Weight class	Anti-shock applications (1)				Anti-vibration applications (2)			
	Shear mounted		Compression mounted		Shear mounted		Compression mounted	
	Number of mountings per head (3)	Catalog number	Number of mountings per head (3)	Catalog number	Number of mountings per head (3)	Catalog number	Number of mountings per head (3)	Catalog number
1	2	XSZSMK	Not recommended		2 or 4	XSZSMK	2	XSZSMK1
	2	XSZSMK1			2 or 4	XSZSMK1		
2	2 or 4	XSZSMK	2	XSZSMK1	2 or 4	XSZSMK	2	XSZSMK
	2 or 4	XSZSMK1			2 or 4	XSZSMK1	2 or 4	XSZSMK1
3	2	XSZSMK2			2	XSZSMK2		
	4	XSZSMK	2	XSZSMK	2 or 4	XSZSMK	2 or 4	XSZSMK
	4	XSZSMK1	2 or 4	XSZSMK1	4	XSZSMK1	4	XSZSMK1
4	2 or 4	XSZSMK2			2 or 4	XSZSMK2		
	4	XSZSMK	2	XSZSMK	4	XSZSMK	2	XSZSMK
	4	XSZSMK1	4	XSZSMK1	4	XSZSMK1	4	XSZSMK1
	2	XSZSMK2			2 or 4	XSZSMK2		

(1) Low frequency, high amplitude applications, such as punching presses where a powerful shock can exist.

(2) High frequency, low amplitude applications, such as offset printing machines where constant vibration can exist.

(3) Head: transmitter, receiver or mirror.

Shock absorber specifications

Characteristics per shock absorber	Compression mounted			Shear mounted			
	Maximum load	Torque	Natural frequency	Maximum load	Torque	Natural frequency	
	lb (kg)	lb•in (N•m)	Hz	lb (kg)	lb•in (N•m)	Hz	
For anti-vibration kit	XSZSMK	18.0 (8.16)	222.5 (25.16)	11	3.0 (1.36)	27.7 (3.13)	9.5
	XSZSMK1	4.8 (2.177)	96.1 (10.86)	14	2.5 (1.13)	20.7 (2.34)	9
	XSZSMK2	55.0 (24.94)	949.7 (107.39)	13	23.0 (10.43)	132.2 (14.94)	7.5

Catalog numbers of anti-vibration kits

Description	For use with	Catalog number	Weight lb (kg)
Anti-vibration kit consisting of 8 shock absorbers, 90° mirror adapters stud mounting. 16 washers and 16 nuts included with kit.	All light curtain types and	XSZSMK	0.07 (0.030)
		XSZSMK1	0.04 (0.020)
		XSZSMK2	0.1 (0.045)
Mounting kit for XUSLN (2 brackets)	Anti-vibration kit	XUSLZ227	1.0 (0.450)

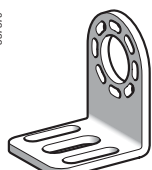
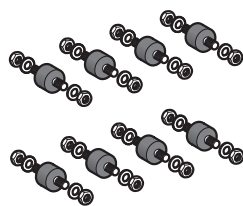

XUSLZ227

Specifications: page 7/42

Catalog Numbers: page 7/42

Dimensions: page 7/45

Mounting base for light curtains and mirrors		XUSZC●●●●	
Environmental specifications			
Ambient air temperature	Operating	°F (°C)	-13 to +158 (-25 to +70)
	Storage	°F (°C)	-13 to +158 (-25 to +70)
Materials		Mounting base: steel End protection: black polycarbonate, 20% fiberglass	

Catalog Numbers

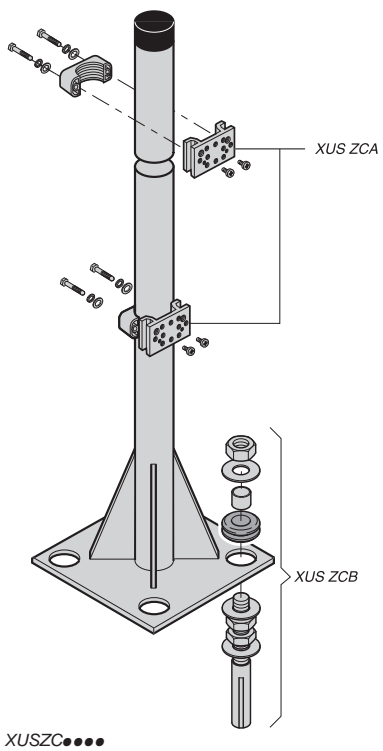

Mounting bases						
Désignation	For use with			Protected height	Catalog number	Weight
	Light curtains Height	Mirrors Height	IP 67 tube Height			
	in. (mm)	in. (mm)	in. (mm)	in. (mm)		lb (kg)
Mounting base XUSZC●●●●	5.9–35.4 (150–900)	7.2–35.2 (182–894)	19.8–38.6 (503–981)	47.2 (1200)	XUSZC1200	25 (11.340)
	36.2–59.1 (920–1500)	39.2–59.2 (995–1503)	43.4–63.8 (1102–1620)	70.9 (1800)	XUSZC1800	35 (15.880)
	59.8–70.9 (1520–1800)	63.2–67.2 (1605–1706)	68.5–76.3 (1740–1939)	82.7 (2100)	XUSZC2100	45 (20.410)
	75.6–82.5 (1920–2095)	75.2 (1910)	79.6–84.3 (2021–2141)	94.5 (2400)	XUSZC2400	60 (27.220)
	–	88.2 (2240)	92 (2336)	122 (3100)	XUSZC3100	66 (29.940)

Accessories			
Description	For use with	Catalog number	Weight lb (kg)
Mounting kit (sold in lots of 2)	Mounting base XUSZC●●●●	XUSZCA	1.0 (0.450)
Floor mounting kit Consisting of: 4 bolts, 4 rawplugs, 12 washers, 8 standard nuts, 4 lock nuts, 4 rubber insulators, 4 spacers (tube)	Mounting base XUSZC●●●●	XUSZCB	1.0 (0.450)

90° mirror adapters + Mounting clamps

XUSZM●●●●/XUSZA●●●●

Mounting clamp (quantity 2)

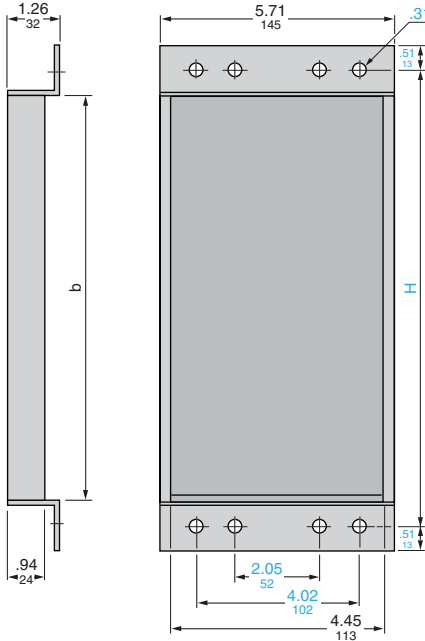

XUS			
Glass	Stainless steel	b in. (mm)	H in. (mm)
ZM0102	ZA102	5.5 (140)	0.7 (182)
ZM0152	ZA152	7.5 (191)	9.2 (233)
ZM0305	ZA0305	13.5 (343)	15.2 (386)
ZM0457	ZA0457	19.5 (495)	21.2 (538)
ZM0508	ZA0508	21.5 (546)	23.2 (589)
ZM0610	ZA0610	25.5 (648)	27.2 (690)
ZM0711	ZA0711	29.5 (749)	31.2 (792)
ZM0762	ZA0762	31.5 (800)	33.2 (843)
ZM0813	ZA0813	33.5 (851)	35.2 (894)
ZM0914	ZA0914	37.5 (953)	39.2 (995)
ZM1016	ZA1016	41.5 (1054)	43.2 (1097)
ZM1067	ZA1067	43.5 (1105)	45.2 (1148)
ZM1219	ZA1219	49.5 (1257)	51.2 (1300)
ZM1321	ZA1321	53.5 (1359)	55.2 (1402)
ZM1372	ZA1372	55.5 (1410)	57.2 (1452)
ZM1422	ZA1422	57.5 (1461)	59.2 (1503)
ZM1524	ZA1524	61.5 (1562)	63.2 (1605)
ZM1626	ZA1626	65.5 (1664)	67.2 (1706)
ZM1830	ZA1830	73.5 (1867)	75.2 (1910)
ZM2134	ZA2134	85.5 (2172)	87.2 (2214)

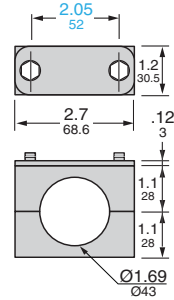

Dual Dimensions: Inches
Millimeters

Protective cover

XUSZW●●● for XUL B/D

XUS b in. (mm)

XUSZWSP for XUSLP

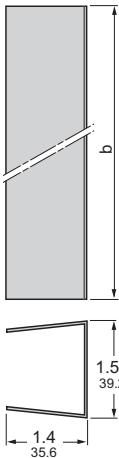

LZWB0280	12.2 (310)
LZWB0320	13.8 (350)
LZWB0360	15.4 (390)
LZWB0440	18.5 (470)
LZWB0520	21.7 (550)
LZWB0600	24.8 (630)
LZWB0680	28 (710)
LZWB0720	29.5 (750)
LZWB0760	31.1 (790)
LZWB0880	35.8 (910)
LZWB0920	37.4 (950)
LZWB0960	39 (990)
LZWB1040	42.1 (1070)
LZWB1120	45.3 (1150)
LZWB1200	48.4 (1230)
LZWB1360	54.7 (1390)
LZWB1400	56.3 (1430)
LZWB1520	61 (1550)
LZWB1560	62.6 (1590)
LZWB1640	65.7 (1670)
LZWB1720	68.9 (1750)
LZWB1800	72 (1830)
LZWB1920	76.8 (1950)
LZWB2120	84.6 (2150)

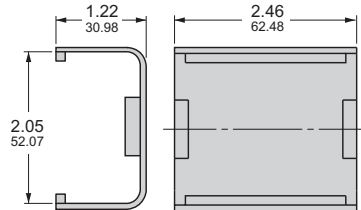

7

Anti-vibration kits (1)

XSZSMK

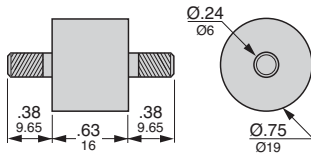

XSZSMK1

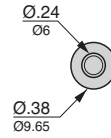
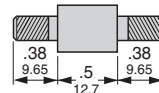

XSZSMK2

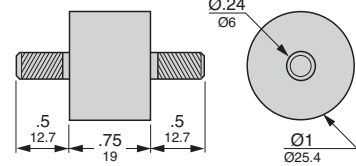

(1) The anti-vibration kit consists of 8 shock absorbers, 16 washers and 16 nuts.

Mounting brackets for anti-vibration kit

XUSLZ227 and XUSLN

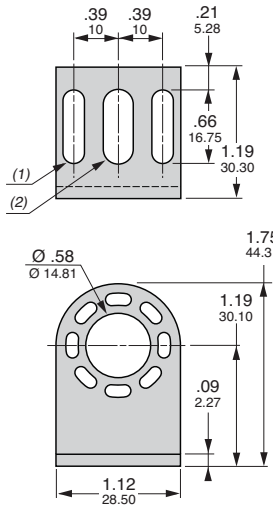

Dual Dimensions: Inches
 Millimeters

(1) 2 elongated holes $\varnothing 0.2 \times 0.7$ in. ($\varnothing 5.10 \times 16.75$ mm).
 (2) 1 elongated hole $\varnothing 0.3 \times 0.7$ in ($\varnothing 6.75 \times 16.75$ mm).

Mounting base

XUSZC●●●●

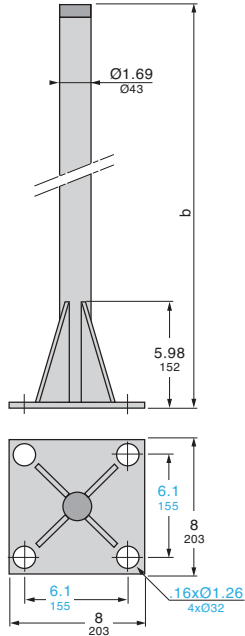

XUS	b in. (mm)
ZC1200	47.3 (1200)
ZC1800	70.9 (1800)
ZC2100	82.7 (2100)
ZC2400	94.5 (2400)
ZC3100	122 (3100)

Floor mounting kit (quantity 4) for mounting base XUSZC●●●●

XUSZCB

Scale 2.5

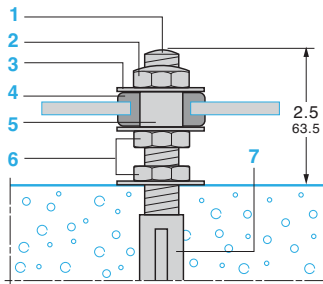

- 1 Bolt
- 2 1 lock nut
- 3 3 washers
- 4 Rubber insulator
- 5 Spacer (tube)
- 6 2 standard nuts
- 7 Rawplug

Dual Dimensions: Inches
Millimeters

Dimensions

ABL8RPS24●●●
common side view

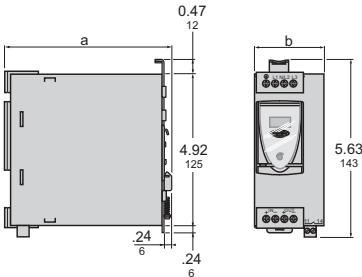

ABL8	a in. (mm)	b in. (mm)
RPS24030	4.7 (120)	1.7 (44)
RPS24050	4.7 (120)	2.2 (56)
RPS24100	5.5 (140)	3.3 (85)

Dual Dimensions: Inches
Millimeters

Internal wiring diagrams

ABL8RPS24030

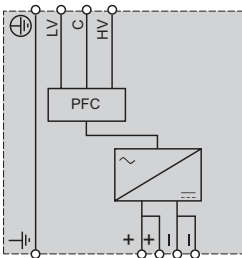

ABL8RPS24050

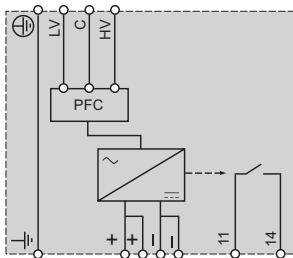

ABL8RPS24100

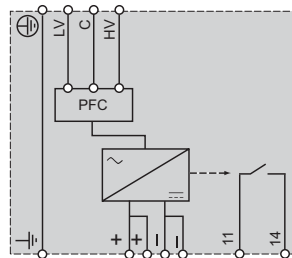

Safety detection solutions

Preventa® XPSCM safety modules and XU2S single-beam photoelectric sensors
 With a test input associated with a built-in Muting function

Operating principle

XPSCM safety modules, when combined with XU2S single-beam photoelectric sensors (periodically tested), form a category 2 light curtain conforming to standards IEC/EN 61496 parts 1 and 2 and EN 60825-1.

The connection of 1–4 pairs of XU2S photoelectric sensors makes it possible to create a protected space up to 47.2 in. (1200 mm) high, conforming to EN 999/ISO 13855, and 26.2 ft (8 m) long.

The built-in Muting function allows for the automatic passage of loaded pallets or parts for machining, without interrupting the transportation movement. When the system is engaged by the operating control (in series with the main circuit feedback loop) and the light protection is not interrupted, the main circuit is closed by the two safety relays of the XPSCM module.

An interruption of the protection field causes the safety outputs to open instantaneously, and the process PLC receives a stop command. The LED on the XPSCM front panel changes from green to red. The Open state is maintained until the module is restarted using the start button.

The Muting function allows the light protection to be inhibited (muted). This function allows a trolley transporting materials to pass through without triggering the main circuit. The Muting function cannot be activated by energizing the inhibition devices unless the safety outputs have been switched on beforehand.

To trigger the Muting function, the inhibition devices (muting sensors) must be activated within the 3-second interval. This synchronization time for the two inhibition inputs can be deactivated by connecting two configuration terminals. The muting cycle has a maximum duration of 60 seconds. During this period, materials can be transported through the protection field without deactivating the safety outputs. The 60 second limit value of the muting cycle may be made infinite by connecting two configuration terminals.

During the muting operation process, a light indicating the muting state is controlled by the XPSCM module. The indicator light comes on when a muting signal is generated, and indicates the inhibition of the protection function. An indicator light error (short-circuit, open-circuit) will be recognized, and will deactivate the Muting function.

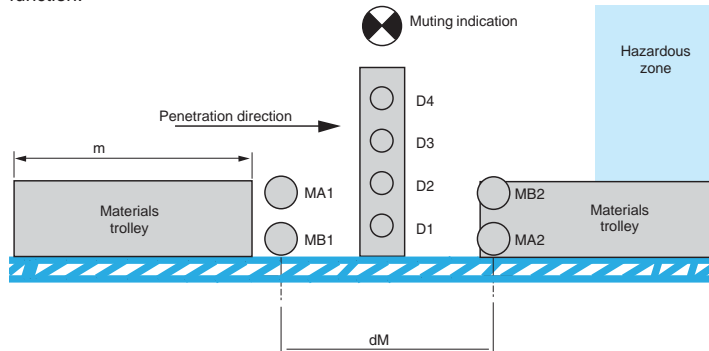

D1, D2, D3, D4: monitoring photoelectric sensors
 MA1, MB1, MA2, MB2: muting photoelectric sensors
 m = trolley length
 dM = distance between MA1/MB1 and MA2/MB2

Conditions to be observed for the Muting function

- Muting sensors must be of the XU2 M18PP340 thru-beam or XU9 M18PP340 polarized reflex type or mechanical limit switches with contacts.
- $dM \leq m$ to obtain continuous validation of the Muting function.
- Avoid the intrusion of persons during the muting phase. This phase is indicated by an indicator light on the muting indicator output of the XPSCM module.
- A materials transportation trolley (i.e., automatically guided vehicle, or AGV) must generate the muting signal before it enters the protection field, and interrupt the muting signal on exiting once it has cleared all the sensors of the protection field.

Safety detection solutions

Preventa® XPSCM safety modules and
XU2S single-beam photoelectric sensors
With a test input associated with a built-in
Muting function

Specifications of safety modules			
Module type		XPSCM1144	XPSCM1144P
Products designed for max. use in safety related parts of control systems conforming to EN 954-1		Category 2 (type 2) conforming to IEC/EN 61496-1	
Ambient air temperature		°F (°C) Operation: +14 to +131 (-10 to +55). Storage: -13 to +185 (-25 to +85)	
Degree of protection conforming to IEC 529		Terminals: IP 20, enclosure: IP 40	
Supply Voltage		V --- 24, voltage limits: ±20%	
Maximum power consumption		W < 15, with thru-beam photoelectric sensors and muting signaling	
Module fuse protection		Internal, electronic	
Rated insulation voltage (Ui)		V 300 (degree of pollution 2 conforming to EN/IEC 60947-5-1, DIN VDE 0110 parts 1 and 2)	
Rated impulse withstand voltage (Uimp)		kV 4 (overvoltage category 3, conforming to EN/IEC 60947-5-1, DIN VDE 0110 parts 1 and 2)	
Inputs for sensors	Number of inputs to be monitored	4 (terminals Z1, Z2, Z3, Z4)	
	Input voltage	V --- 24	
	Supply voltage of sensors	V --- 24 (terminal U+/U-)	
	Supply current of sensors	mA < 200	
Inputs for the Muting function	Number of muting inputs	2 (terminals MA, MB)	
	Input voltage	V --- 24 (terminal U+/U-)	
	Maximum current	mA < 200	
	Synchronization time for the activation of the MA/MB muting signal	s 3 (±20%)	
	Muting maximum duration	s 60 (-10 to +30%)	
Single-beam thru-beam photoelectric sensors for input monitoring Z1-Z2-Z3-Z4 - sensors authorized for the protection field (max. 4) - muting sensors - sensor supply resistivity		XU2S18PP340●●● (infrared) XU2 M18PP340●●● or XU9 M18PP340●●● photoelectric sensors or XC limit switches Ω 10 max.	
Safety outputs - number and type - solid-state output breaking capacity - breaking capacity in AC-15 - breaking capacity in DC-13 - maximum thermal current (Ithe) - sum of maximum thermal current - minimum current (volt-free contact) - minimum voltage (volt-free contact) - short-circuit protection		2 N.O. (terminals 13-14, 23-24), hard contacts 4 N.O. 24 V/20 mA, (Y33-Y34, Y33-Y44, Y33-Y54, Y33-Y64) VA C300: inrush 1800, maintained 180 24 V/1.5 A, L/R = 50 ms A 5.6 A 11 mA 10 V 17 A 4 gG or 6 fast-acting fuse cartridge, conforming to EN/IEC 60947-5-1 and DIN VDE 0660 part 200	
Muting signaling sensors for incandescent lamp		Number 1 (terminal H1), maximum power: 6.5 W/--- 24 V, minimum power: 4 W/--- 24 V	
Response time on input change of state		ms < 25	
Electrical life		See page 2/172 of the <i>Machine Safety Products</i> catalog, MKTED208051EN-US.	
Display		4 LEDs	
Connection	Type	Captive screw clamp terminals	
	- 1-wire connection	Without cable ends	Solid or flexible cable: 26-14 AWG
		With cable ends, without bezel	Flexible cable: 24-14 AWG
		With cable ends, with bezel	Flexible cable: 24-16 AWG
	- 2-wire connection	Without cable ends	Solid or flexible cable: 26-18 AWG
		With cable ends, without bezel	Flexible cable: 24-18 AWG
	With cable ends, double with bezel	Flexible cable: 22-14 AWG	
		Captive screw clamp terminals, separate, removable terminal block	Solid or flexible cable: 24-14 AWG
			Flexible cable: 24-14 AWG
			Flexible cable: 24-14 AWG
			Solid cable: 24-18 AWG, Flexible cable: 24-16 AWG
			Flexible cable: 24-18 AWG ²
			Flexible cable: 22-14 AWG

Specifications of photoelectric sensors			
Product certification		CE, conforming to EN/IEC 61496-1/-2 and EN/IEC 60825-1	
Ambient air temperature		°F (°C) Operation: -13 to +131 (-25 to +55) (infrared transmission sensors), Storage: -40 to +158 (-40 to +70)	
Vibration resistance		7 gn (10-55 Hz), conforming to EN/IEC 60068-2-6	
Shock resistance		30 gn, 3 axes: 3 times, conforming to EN/IEC 60068-2-27	
Degree of protection		IP 67 conforming to EN/IEC 60529	
Connection	Pre-cabled	PVC cable, diameter 0.20 in. (5 mm), 16.4 ft (5 m) long wire: 4 x 22 AWG (0.34 mm ²) for thru-beam transmitter)	
	Connector	M12 male connector, 4-pin (suitable jumper cables and female connectors M12, 4-contact. See the <i>Global Detection</i> catalog.)	
Materials		Case: nickel-plated brass (infrared transmission sensors). Lenses: PMMA	
Nominal sensing distance		ft (m) 26.2 (8) (infrared transmission sensors)	
Rated supply voltage		V --- 12-24 (with protection against reverse polarity)	
Voltage limits		V --- 10-30 V (including ripple)	
Switching capacity (sealed)		mA ≤ 100 mA (with overload and short-circuit protection)	
Voltage drop, closed state		V ≤ 1.5	
Current power consumption, no-load		mA ≤ 35	
Maximum switching frequency		Hz 500	
Delays		ms Response: ≤ 1; recovery: ≤ 1	
Principle: page 7/48	Specifications: page 7/49	Catalog Numbers: page 7/50	Dimensions: page 7/53
			Wiring diagrams: page 7/53



Safety detection solutions

Preventa® XPSCM safety modules and XU2S single-beam photoelectric sensors
 With a test input associated with a built-in Muting function



XPSCM1144

Safety modules

Description	Type of terminal block connection	Number of safety circuits	Additional outputs	Supply	Catalog number	Weight oz (kg)
Safety modules for monitoring single-beam photoelectric sensors, with a test input associated with a built-in Muting function	Integrated in module	2	4	24 V	XPSCM1144	12.35 (0.350)
	Separate, can be removed from module	2	4	24 V	XPSCM1144P	12.35 (0.350)

Safety detection solutions

Preventa® XPSCM safety modules and XU2S single-beam photoelectric sensors

With a test input associated with a built-in Muting function



XU2S18●P340L5



XU2S18●P340WL5



XU2S18KP340L5T



XU2S18KP340WL5T



XU2S18PP340DR



XU2S18PP340WL5R

Single-beam photoelectric sensors with a test input

Description	Transmission type	Line of sight	Connection	Catalog number	Weight oz (kg)
PNP thru-beam pair (transmitter + receiver) Light or dark programmable switching	Infrared Sensing distance: 26.2 ft (8 m)	Along case axis	Pre-cabled L = 16.4 ft (5 m)	XU2S18PP340L5	17.11 (0.485)
			M12 connector	XU2S18PP340D	5.47 (0.155)
			90° to case axis Pre-cabled L = 16.4 ft (5 m)	XU2S18PP340WL5	17.11 (0.485)
			M12 connector	XU2S18PP340WD	5.47 (0.155)
Thru-beam transmitter alone (for XPSCM1144●)	Infrared	Along case axis	Pre-cabled L = 16.4 ft (5 m)	XU2S18KP340L5T	8.29 (0.235)
			M12 connector	XU2S18KP340DT	2.65 (0.075)
			90° to case axis Pre-cabled L = 16.4 ft (5 m)	XU2S18KP340WL5T	8.29 (0.235)
			M12 connector	XU2S18KP340WDT	5.47 (0.155)
PNP thru-beam receiver alone (for XPSCM1144●)	Infrared	Along case axis	Pre-cabled L = 16.4 ft (5 m)	XU2S18PP340L5R	8.82 (0.250)
			M12 connector	XU2S18PP340DR	2.82 (0.080)
			90° to case axis Pre-cabled L = 16.4 ft (5 m)	XU2S18PP340WL5R	8.82 (0.250)
			M12 connector	XU2S18PP340WDR	2.82 (0.080)



Safety detection solutions

Preventa® XPSCM safety modules and XU2S single-beam photoelectric sensors
With a test input associated with a built-in Muting function

Functional diagram of XPSCM module

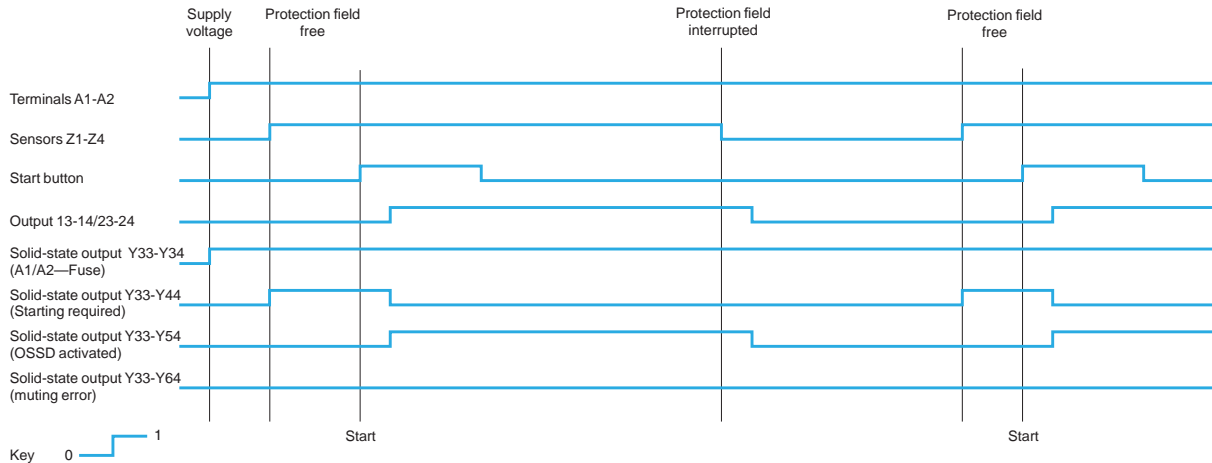

Functional diagram of the XPSCM module with Muting function

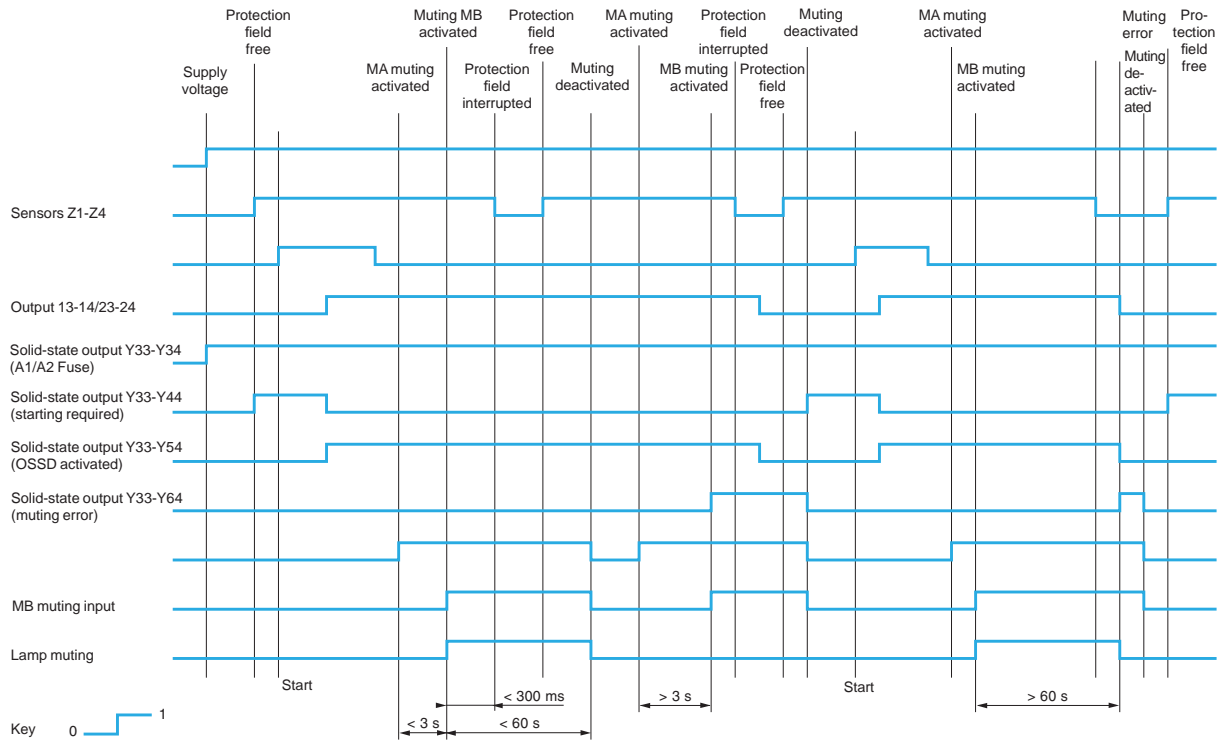

Key to LEDs

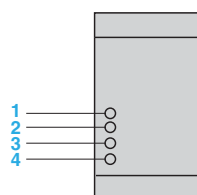

- 1 A1-A2 supply voltage, electronic internal fuse status
- 2 Signaling for restarting
- 3 Safety output closed
- 4 Safety output open

7

Operation

Output state (PNP) indicator, yellow LED (illuminated when sensor output is on)

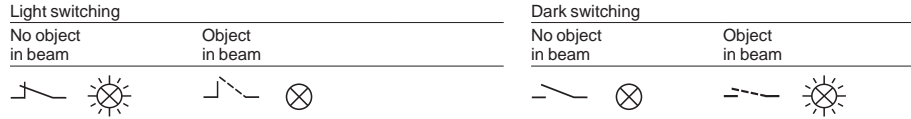

Curves

Infrared detection curve

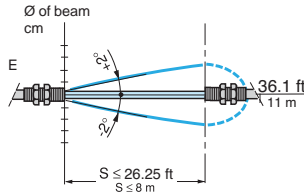

Functional check

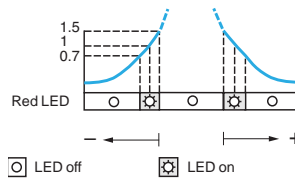

Dimensions

XU2S18PP340L5, XU2S18PP340L5L

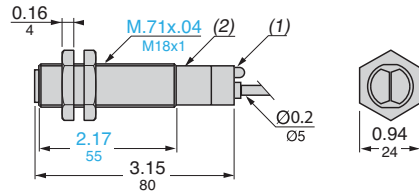

XU2S18PP340D

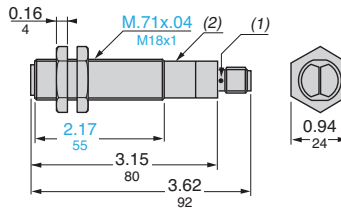

(1) LED

(2) Potentiometer

Mounting nut tightening torque: 17.7 lb-ft (24 N.m)

Connector tightening torque: 1.5 lb-ft (2 N.m)

XU2S18PP340WL5

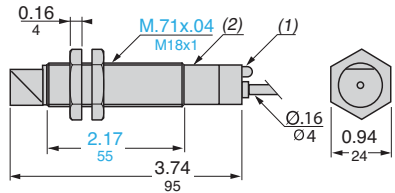

XU2S18PP340WD

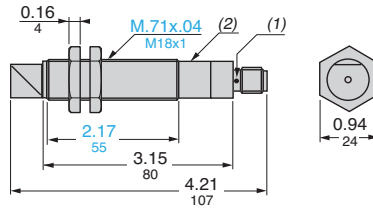

(1) LED

(2) Potentiometer

Mounting nut tightening torque: 17.7 lb-ft (24 N.m)

Connector tightening torque: 1.5 lb-ft (2 N.m)

Dual Dimensions: Inches
Millimeters

Wiring diagrams (3-wire ---)

Cable connection

Transmitter

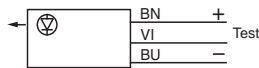

Receiver

Light switching (no object present).
PNP output

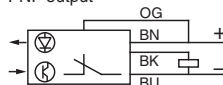

Receiver

Dark switching (no object present). PNP output

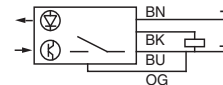

Plug-in connector

Transmitter

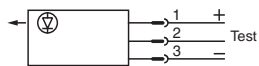

Receiver

Light switching (no object present).
PNP output

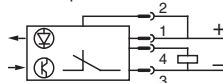

Receiver

Dark switching (no object present). PNP output

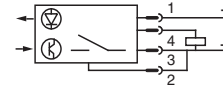

Cable connections

(-) BU (Blue)
(+) BN (Brown)
(OUT) BK (Black) (receiver)
(Prog.) OG (Orange) (receiver)
(Test) VI (Violet) (transmitter)

Connector diagrams

Sensor connector pin view

Transmitter

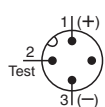

Receiver

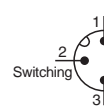

Beam break test (for transmitter only)

Beam made

Beam broken

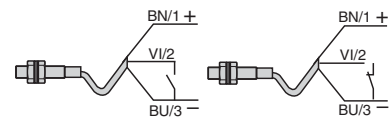

Wiring Diagrams (continued)

Connection of XPSCM module with 4 pairs of XU2S single-beam sensors

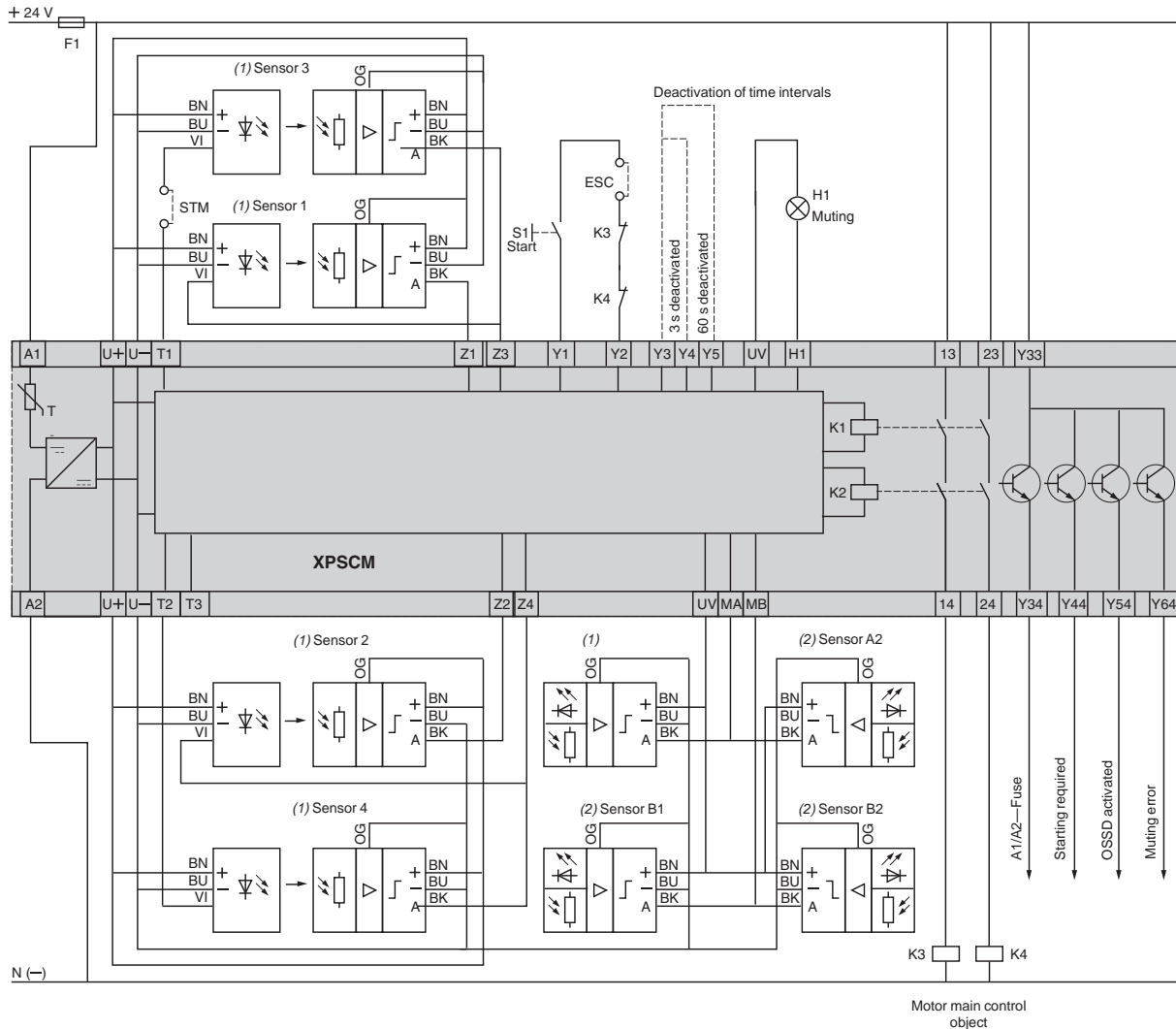

7

XU2S sensors can be programmed for light switching or dark switching (dark switching with sensors 1 and 3 and light switching with sensors 2 and 4, for example).
ESC: external start conditions
Y1-Y2: feedback loop.
STM: for stopping time measurement.
(1) Protection field sensors
(2) Muting sensors

Safety detection solutions

Preventa® XPSCM safety modules and XU2S single-beam photoelectric sensors
With a test input associated with a built-in Muting function

Wiring Diagrams (continued)

Connection of XPSCM module with 1 pair of XU2S sensors (dark switching)

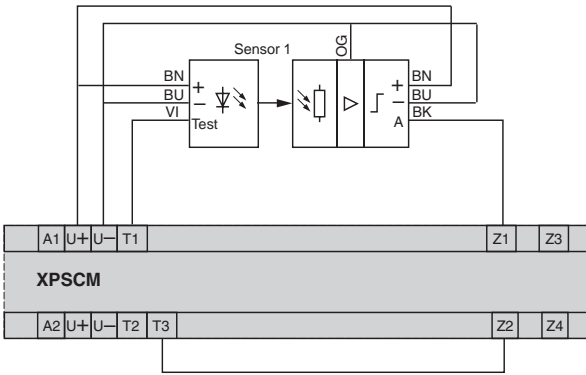

Connection of XPSCM module with 2 pairs of XU2S sensors (dark switching)

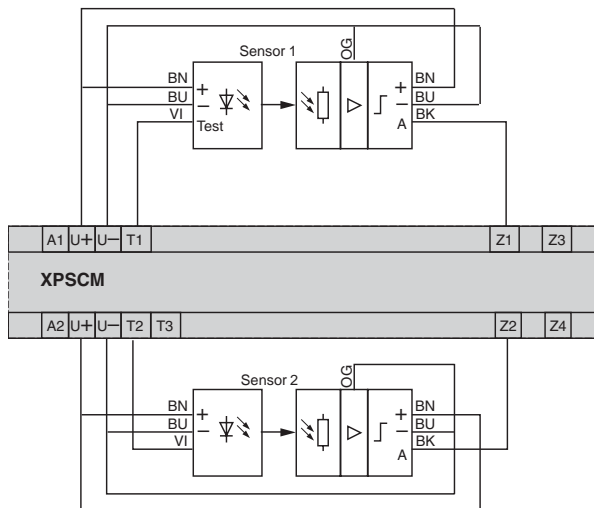

Connection of XPSCM module with 3 pairs of XU2S sensors (2 for dark switching, 1 for light switching)

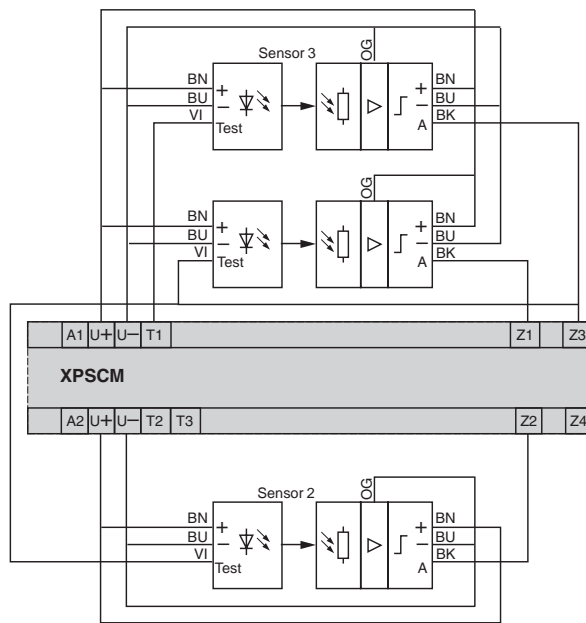

Connection of XPSCM module with 4 pairs of XU2S sensors (2 for dark switching, 2 for light switching)

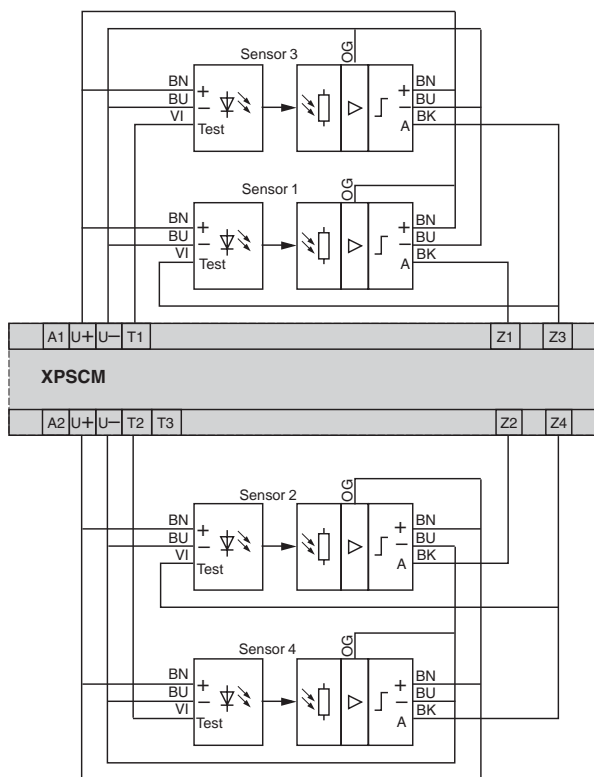

Light curtain application and installation

Protection of personnel

Protection of Personnel

Safety light curtains are electro-sensitive protective equipment (ESPE) designed to help protect personnel operating or working around industrial machinery, by sending stop signals to the machine control to stop the hazardous movement as soon as one of the light beams is broken.

In particular, they help provide protection for personnel operating hazardous machinery, but they are equally suitable for use with many other types of machines. They make it possible to help protect personnel while allowing free access to machines.

The absence of a door or guard reduces the time required for loading, inspection, or adjustment operations, and it makes access easier.

Directives and Standards—These Safety Light Curtains Conform to:

- The essential protection requirements of the Electromagnetic Compatibility (EMC) Directive 89/336/EEC, 92/31/EEC, 93/68/EEC,
- Relevant essential health and safety requirements (EHSR's) of the European Machinery Directive 98/37/EEC,
- Low Voltage Directives 73/23/EEC and 93/68/EEC,
- Standard EN 61496-1 (electro-sensitive protective equipment: ESPE),
- EN 954-1,
- ANSI B11-19,
- Draft standard EN 999 (installation conditions),
- UL 61496 Type 4 requirements.

Applications—The Main Applications Are:

For Type 2 Light Curtains:

- Packaging and Assembly Plants
- Conveyor and Mechanical Handling Systems
- Warehousing and Storage Systems
- Waste Disposal Skips
- Robot Areas

For Type 4 Light Curtains

- Presses (all types), Shears and Trimmers
- Hoisting Equipment
- Saws (all types)
- Machine Tools (lathes, milling machines, machining centers)
- Woodworking Machines (truing, lathes, spindle molding machines, side and face milling cutters)
- Textile Machinery (carding machines, weaving looms, steam rooms)
- Assembly Machines
- Assembly Robots

Safety Requirements—Detection of Anomalies that May Jeopardize Machine Safety and Stopping

The machine design and its controls must have the same level of safety as that of the safety light curtain so as to ensure that the machine is able to immediately stop its hazardous movement if something enters the zone protected by the safety light curtain.

It must be impossible to enter the protected zone without breaking the protective light beams. The safety light curtain must therefore be installed so that the light curtain cannot be avoided.

The restarting of the machine must only be possible when there is no hazard present and when there is no one in the hazardous zone.

Light curtain application and installation

Standards and basic requirements

Safety Systems

Safety systems are comprised of many components. No one safety component will insure the safety of the system. The design of the complete safety system should be considered before you begin. It is very important to follow applicable safety standards when installing and wiring these components.

Standards to be Followed—United States

Standards listed below refer to presses and other metal working and general equipment. This is not a complete listing of all applicable standards to be referenced when using light curtains. There may be other OSHA, ANSI, ANSI/RIA, NEC, NFPA, national, state, and local codes that may include requirements for installation of light curtains on machinery.

- OSHA 1910.211
- OSHA 1910.212
- OSHA 1910.217
- ANSI B11.1
- ANSI B11.19
- ANSI B11.20
- ANSI/RIA R15.06

Directives and Standards to be Followed—Europe

Standards listed below refer to general machinery. This is not a complete listing of all applicable standards to be referenced when using light curtains. There may be other European and local codes that may include requirements for installation of light curtains on machinery.

- (NF) E09-010
- DIN 31001
- BS 5304
- EN 294
- EN 811
- EN 999
- EN 954-1
- EN 61496-1

Light Curtains in the United States—Basic Requirements

- This device must be installed, set up, and serviced only by authorized personnel. ANSI defines Authorized Personnel in ANSI B30.2-1983.
- The user must follow all applicable codes, standards, and regulations. Standards specifically referenced in this document need to be followed: ANSI B11.1 through B11.20, OSHA 29 CFR 1910 standards, and ANSI/RIA R15.06 standard. There may be other national and local standards that may also need to be followed.
- Do not alter or modify this equipment.
- Light curtains must be securely mounted to a rigid surface using the provided mounting brackets.
- The machine must be capable of stopping immediately at any place in its stroke after receiving a stop signal.
- Light curtains must not be used with single stroke (full revolution clutched) machinery.
- Read and understand the sections on Calculating Minimum Safety Distances of this catalog for important details regarding standards, spacings and safe operating distances, and stopping times before beginning installation.
- Light curtains must not be used as a lockout device to meet OSHA lock-out/tag-out requirements.
- Light curtains will not protect machine operators and other personnel from liquids, gases, chips, hot surfaces, and other debris from point of operation.
- Light curtains must be sized and installed so that the machine operator cannot reach over, under, or around the sensing field to reach the point of operation.
- Light curtains must be installed so that machine operators cannot position themselves between the hazardous area (pinch point) and the light curtain.
- Light curtains currently cannot be used as PSDI devices to initiate machine movement on mechanical power presses. For PSDI, refer to OSHA 29 CFR 1910.217 (h), the various appendices referenced on PSDI, and OSHA mandatory regulations requiring third party approval.

Using the light curtain to initiate a machine after an object is removed from the sensing area is called Presence Sensing Device Initiation (PSDI). Use of PSDI places additional requirements on the guarding and safety controls. It can restrict advanced light curtain features such as floating blanking and Exact Channel Selection (ECS) blanking. Contact your local sales office for further information. Other sources of references for PSDI include: ANSI RIA 15.06-1999, OSHA 1910.217(h), and ANSI B11.2-1995.

Light curtain application and installation

Minimum safety distances

Minimum Safety Distance

Light Curtains in the United States (Vertical Mount)

The basic formulas for calculating minimum safety distances for light curtains mounted vertically are listed below. These formulas apply to ALL light curtains, including perimeter and point of operation light curtains. ANSI B11.1 is listed first, OSHA 29 CFR 1910.217 listed next.

ANSI B11.1:

This formula applies specifically to the guarding of mechanical power presses, but it is typically used for other applications as well.

$$D_s = K \times (T_s + T_c + T_r + T_{bm}) + D_{pf}$$

D_s = Minimum safe distance between the light curtain sensing area to the nearest point of operation potential hazard.

K = Hand speed constant of 63 in/s. This is the standard minimum accepted value for both ANSI and OSHA. ANSI recognizes that this constant may not be optimal, and that the user should consider all factors before deciding on the value of the K factor to use in the above formula.

T_s = Stop time of the machine (press), as measured from the final control element. It is measured at the maximum velocity of the press, usually at 90° of press rotation on the downstroke.

T_c = Response time of the control circuit to activate the braking system.

NOTE: T_s and T_c are usually measured as one value by a stop time measurement device.

T_r = Response time of the light curtain.

T_{bm} = Additional time allowed for the brake monitor to compensate for wear and variations in the stopping time. Brake monitors will stop the machine (press) when the stop time of the machinery exceeds a pre-set limit.

NOTE: If a brake monitor is not installed on the machine, a factor must be added to the measured stop time to include brake wear. Generally, brake monitors add approximately 20% to 25% additional stop time. To determine the actual factor to be used, contact the machine manufacturer.

D_{pf} = Penetration depth factor, to provide for possible penetration through the sensing field by fingers or hands before detection occurs. This value is determined by the Penetration Depth Factor Chart from ANSI B11.1 (see Penetration Depth Factor graph below). Alternately, the following ANSI formula can be used: $D_{pf} = 3.4 (S - 0.276)$, where S = minimum object sensitivity.

Example: For devices with minimum object sensitivity of 0.55 in. (14 mm):

$$D_{pf} = 3.4 \times (0.55 - 0.276) = 0.94 \text{ in. (23.88 mm)}$$

For devices with minimum object sensitivity of 1.18 in. (30 mm):

$$D_{pf} = 3.4 \times (1.18 - 0.276) = 3.07 \text{ in. (77.98 mm)}$$



Penetration Depth Factor

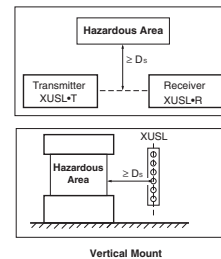
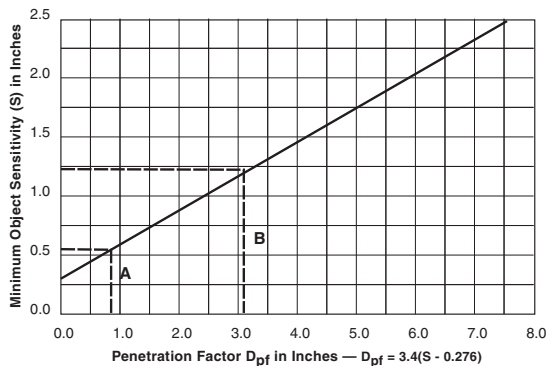

A = Finger Protection 0.55 in. (14 mm) has a D_{pf} of 0.94 in. (23.88 mm)

B = Hand Protection 1.18 in. (30 mm) has a D_{pf} of 3.07 in. (77.98 mm)

Light curtain application and installation

Minimum safety distances *(continued)*

Minimum Safety Distance *(continued)*

OSHA: CFR 1910.217 (c)(3)(iii)(e)

This formula applies specifically to the guarding of mechanical power presses, but it is typically used for other applications as well.

$$D_s = 63 \text{ in/s} \times T_s$$

Where:

D_s = Minimum safety distance (in.)

63 in/s = hand speed constant

T_s = Stopping time of the press measured at approximately 90° position of the crankshaft rotation (seconds).

Stop time of the machine (press), as measured from the final control element. It is measured to determine worst case time and maximum velocity of the press, usually at 90° of press rotation on the downstroke.

In addition to the formula above, we recommend that OSHA 1910.217 Table O-10 be followed. Per OSHA, the table below shows the maximum width of openings allowed for a guard based on the distance from the guard (light curtain) to the point of operation hazard. The maximum width of opening in the table below corresponds to the minimum object sensitivity for a light curtain.

Example:

Using the formula: $D_s = 63 \text{ in/s} \times T_s$

if $T_s = 0.10 \text{ sec}$

$D_s = 63 \text{ in.} \times 0.10 = 6.3 \text{ in.}$

- For an XUSL light curtain with a minimum object sensitivity of 0.55 in.:
- Using the example above, the separation distance from the point of operation hazard to the light curtain would be 6.3 in. plus a minimum distance (from table O-10) of 3.5 in., for a total separation distance of 9.8 in. The 3.5 in. was chosen from Table O-10 as the additional distance because the opening (minimum object sensitivity) is 0.55 in. Since 0.55 in. is larger than 0.50 in., the values for 0.50 in. cannot be used. Therefore the next larger opening, 0.625 in., must be used and the distance corresponding to the 0.625 in. opening is 3.5 in.
- For an XUSL light curtain with a minimum object sensitivity of 1.18 in.:
- Using the example above, the separation distance from the point of operation hazard to the light curtain would be 6.3 in. plus a minimum distance (from table O-10) of 7.5 in., for a total separation distance of 13.8 in.
- The 7.5 in. was chosen from Table O-10 as the additional distance because the opening (minimum object sensitivity) is 1.18 in. Since 1.18 in. is larger than 0.875 in., the values for 0.875 in. cannot be used. Therefore the next larger opening, 1.25, must be used, and the distance corresponding to the 1.25 opening is 7.5 in.

NOTE: 3.5 in. = 89 mm, and 7.5 in. = 191 mm.

OSHA 1910.217 Table O-10

Distance of Opening from Point of Operation Hazard (in.)	Maximum Width of Opening (in.)
1/2 to 1-1/2	1/4
1-1/2 to 2-1/2	3/8
2-1/2 to 3-1/2	1/2
3-1/2 to 5-1/2	5/8
5-1/2 to 6-1/2	3/4
6-1/2 to 7-1/2	7/8
7-1/2 to 12-1/2	1-1/4
12-1/2 to 15-1/2	1-1/2
15-1/2 to 17-1/2	1-7/8
17-1/2 to 31-1/2	2-1/8

NOTE: If the light curtain is to be used on machinery that will be standardized throughout North America and Europe, then all minimum distance formulas in "Calculating Minimum Safety Distances" on pages 7/58 through 7/64 must be calculated, and the largest separation distance must be used.

Light curtain application and installation

Minimum safety distances (*continued*)

Light Curtains in Europe (Vertical Mount)—Minimum Safety Distance

The minimum safety distance D_s must be calculated using the following General Formula:

$$D_s \geq K(t_1 + t_2) + C$$

- D_s = Minimum safety (separation) distance between the hazardous area and the light curtain.
- K = Accepted general approach speed of a body or parts of the body. Generally accepted values are: 63 in/s (1600 mm/s).
- t_1 = Response time of the light curtain in seconds. This is the total time from detection of a beam broken to the switching of the outputs of the light curtain.
- t_2 = The time needed to stop all hazardous movements of the machine in seconds. This information is provided by the machine manufacturer. It is the time between the stop instruction of the light curtain and the actual stop of the hazardous machine components.
- C = Additional safety distance. Generally accepted values are:
 0 in. (0 mm) for 0.55 in. (14 mm) minimum object sensitivity
 5.04 in. (128 mm) for 1.18 in. (30 mm) minimum object sensitivity

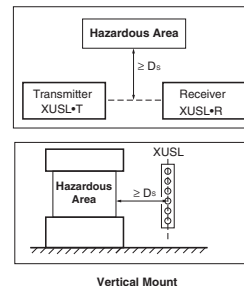

Using Individual Beam Sensors (XPSCM and XU2S Perimeter Light Curtain)

The formula above is modified from a security light curtain where the light beams are all mounted in the same enclosure. Typically, for a system with individual beam sensors, up to 4 photoelectric sensors are used.

General Formula: $D_s \geq K(t_1 + t_2) + C$

- D_s = Minimum safety (separation) distance between the hazardous area and the light curtain.
- K = Accepted general approach speed of a body or parts of the body. Generally accepted values are: 63 in/s (1600 mm/s).
- t_1 = Response time of the light curtain in seconds. This is the total time from detection of a broken beam to the switching of the outputs of the light curtain.
- t_2 = The time (in seconds) needed to stop all hazardous movements of the machine. This information is provided by the machine manufacturer. It is the time between the stop instruction of the light curtain and the actual stop of the hazardous machine components.
- C = Additional safety distance. Generally accepted values are:
 33.5 in. (850 mm) when using several individual photoelectric beams
 47.3 in. (1200 mm) when using a single photoelectric beam

Presses and New Machines

For presses and new machines put into service in accordance with EEC European Machine Safety Directive 89/392, the following parameters and formulas must be used:

	K: in. (mm)	C: in. (mm) XUSL: 0.55 in. (14 mm)	C: in. (mm) XUSL: 1.18 in. (30 mm)
EN Standards	78.74 in. (2000 mm)	0	5.04 in. (128 mm)

Calculations should be made by using the General Formula and parameters K and C from the table above that correspond to the light curtain being used.

If D_s is calculated to be ≤ 19.69 in. (500 mm), calculate the distance using values from the table above.

If D_s is calculated to be > 19.69 in. (500 mm), the calculation can be re-done using the **Alternate Formula** below. If this formula is used, the value for D_s that may be used must be at least 19.69 in. (500 mm). The **Alternate Formula** is:

- For inches: $D_s \geq 63(t_1 + t_2) + C$
- For millimeters: $D_s \geq 1,600(t_1 + t_2) + C$
- D_s must be at least 3.94 in. (100 mm)

Light curtain application and installation

Minimum safety distances (continued)

Special Rules for Presses

The European standards specify that only light curtains or mechanical barriers must be used as safety devices so that, if a person enters the protected area while there are hazardous movements, the machine stops as quickly as possible. Quick Stopping means stopping the the press ram before the operator can reach the hazardous area, when considering the speed at which an operator can move.

For determining the minimum safety distance for particular machines, refer to the following European standards:

- Mechanical power presses: refer to EN692
- Hydraulic presses, pneumatic folding machines, shears, bending and shaping machines: refer to EN693.

Light Curtains Mounted Horizontally or at an Angle

There are applications which may require the light curtain to be mounted horizontally or at an angle instead of vertically. ANSI and OSHA do not include in their standards requirements when mounting light curtains in the horizontal or angular modes. European Standard EN999 does address this type of application.

When using light curtains at an angle of 30° or greater from horizontal, use the formulas listed in the sections for vertical installations. When using light curtains at an angle of less than 30°, use the formulas below.

Parallel Approach to the Hazardous Area

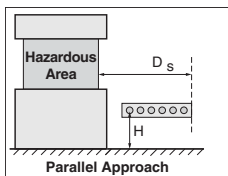

If the direction of approach is parallel to the detection area, the minimum safety distance D_s between the hazardous area and the beam furthest away from the hazardous area, depends on the height H at which the light curtain is installed. This safety distance D_s must be calculated using the following formula:

$$\text{For in: } D_s \geq K(t_1 + t_2) + 33.5$$

$$\text{For mm: } D_s \geq K(t_1 + t_2) + 850 \quad \text{If } 34.45 \text{ in. (875 mm)} < H \leq 39.39 \text{ in. (1000 mm)}$$

D_s = Minimum safety (separation) distance between the hazardous area and the light curtain.

K = Accepted general approach speed of a body or parts of the body. Generally accepted values are: 63 in/s (1600 mm/s).

t_1 = Response time of the light curtain in seconds. This is the total time from detection of a beam broken to the switching of the outputs of the light curtain.

t_2 = The time needed to stop all hazardous movements of the machine in seconds. This information is provided by the machine manufacturer. It is the time between the stop instruction of the light curtain and the actual stop of the hazardous machine components.

H = Height (distance) of light curtain from floor.

Or the following formula is used:

$$\text{For in: } D_s \geq 63(t_1 + t_2) + (47.2 - 0.4H)$$

$$\text{For mm: } D_s \geq 1600(t_1 + t_2) + (1200 - 0.4H) \quad \text{If } 0 < H \leq 34.45 \text{ in. (875 mm)}$$

The maximum allowed height H is 39.39 in. (1000 mm)

Once the height H exceeds 11.81 in. (300 mm), additional protective devices must be used.

Angular Approach to the Hazardous Area

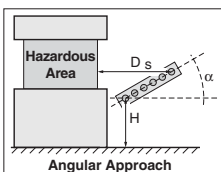

If the operator's direction of approach and the detection area form an angle α , then the formulas used to calculate the safety distance D_s depends on this angle:

- If the angle α is greater than 30°, the formulas used for perpendicular approach (vertical mounting) to the detection area must be used.
- If the angle α is less than or equal to 30°, then the formulas given for the parallel direction of approach (horizontal mounting) to the detection area must be used.

Installation in an L Shape

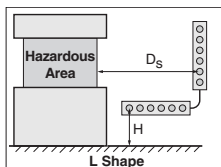

This type of installation uses one light curtain mounted vertically and another light curtain mounted horizontally per the diagram to the left. The maximum allowed height H is 39.37 in. (1000 mm). If height H is greater than 11.81 in. (300 mm), additional protective devices must be used. Distance D_s is calculated from the formulas for light curtains mounted vertically (see page).

NOTE: Europe uses the symbol S instead of D_s . This catalog uses the symbol D_s for consistency and for ease of understanding.

Light curtain application and installation

Prevention of access to hazardous area

Prevention of access over the top of the light curtain

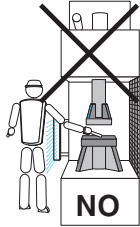

Without additional safety device: insufficient degree of protection

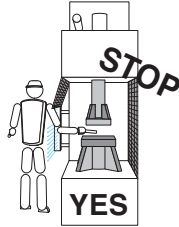

With additional device: light beams broken, the machine stops

Prevention of Access to Hazardous Area

Security light curtains can only be used on machines on which the movement of working components may be *stopped at any time during the hazardous operation phase of the machine*.

These light curtains provide a stop signal, not a control instruction. This stop signal must be stored.

The clearing of the light curtain must not result in the restarting of moving parts or hazardous operation.

Subsequent restarting must only be possible by means of deliberate operation of the appropriate control device, or a start-up procedure after having checked that there is no longer any hazard.

Electrical interfacing between the security light curtain and the machine circuits must meet all applicable codes where the machine will be used.

Where security light curtains do not provide an adequate degree of protection due to their location, additional suitable safety devices, guards, or additional security light curtains must be used to prevent operators from entering the protective light curtain and reaching the hazardous zone (EN 294, EN 811), or from remaining in the area between the hazardous zone and the security light curtain (EN 999).

The position and size of these additional safety devices must be such that it is *impossible for operators to reach the hazardous zone* in any way whatsoever (over the top, from beneath, from behind or from the side) *without breaking the beams of the light curtain*.

These additional safety devices must be:

- Either fixed (if possible, screwed or welded to the machine),
- Or moving (with continuous monitoring of their position if they have to open).

It must be impossible for operators to disconnect or turn off the switching circuits for these additional safety devices.

As well as conforming to standards EN 61496 and EN 699, they must also conform to the following European Standards:

- (NF) E 09-010
- DIN 31001
- BS 5304
- EN 294

Prevention of access from beneath the light curtain

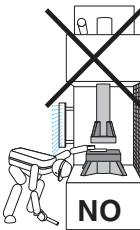

Without additional safety device: insufficient degree of protection

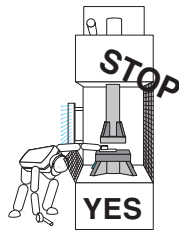

With additional device: light beams broken, the machine stops

Prevention of access from the back of the light curtain

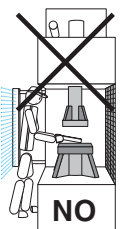

Without additional safety device: insufficient degree of protection

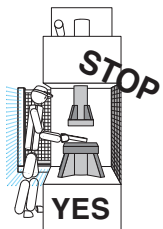

With additional device: light beams broken, the machine stops

Light curtain application and installation

Alignment and mutual interference

Light Curtain Alignment

Light curtains need to be firmly and securely mounted to the machine. The diagrams below show correct and incorrect mounting. Incorrect mounting as shown below will not allow correct alignment.

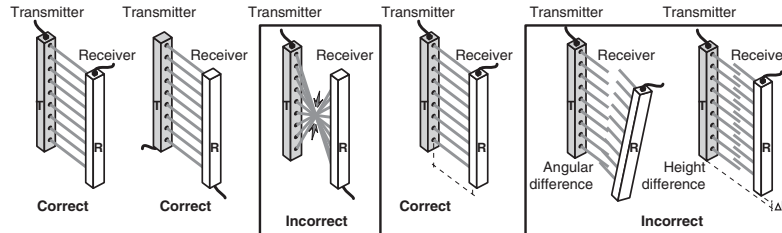

Installation Near Reflective Surfaces

The devices must be installed such that the transmitter and associated receiver are mounted facing each other and correctly aligned for both height and angle.

The effective aperture angle of the optics and transmitter/receiver alignment is 2.5° maximum > 3 m (9.8 ft).

Reflective surfaces located near areas protected by light curtains could interfere with the proper operation of the light curtain. Reflective surfaces may include painted metal, shiny sheet metal, stainless steel, or plastic. These reflective surfaces may allow unwanted stray light rays to “go around” objects entering the sensing area of the light curtain. It is necessary to take into account a minimum distance D between the axes of the nearest beam and the reflective surface. This distance is measured from the mid-point between the transmitter and receiver.

European Standard EN 61496-1 specifies a minimum distance D where:

for $0 < L < 9.84 \text{ ft (3 m)}$, $D = 5.16 \text{ in. (131 mm)}$

for $L > 9.84 \text{ ft (3 m)}$, $D = (0.035 \times L) + 0.2 \text{ in. (5 mm)}$, with a minimum value for D of 5.16 in. (131 mm)

D = minimum distance between the light curtain and reflective surface

L = sensing distance of the security light curtain.

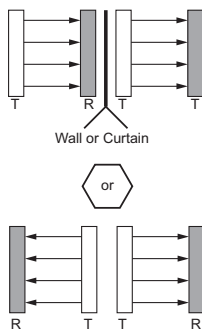
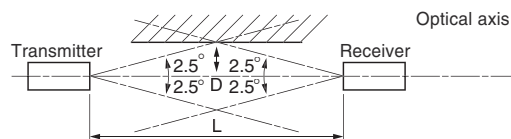

Mutual Interference

Certain configurations may require the installation of 2 (or more) security light curtains side by side.

The products in the XUSL range are designed to provide maximum operating safety (coded infrared light beams).

Setup as illustrated to the left is recommended for maximum performance and safety.

Environments Subject to Interference

Industrial applications sometimes place products in extreme operating conditions, due in particular to:

- Electromagnetic interference generated by the close proximity of variable speed controllers, welding machines or walkie-talkies. The products in the XUSL range are designed to be immune to such interference. They conform to:
 - level 3 conforming to EN 61496-1 (fast transient/burst interference),
 - resistance to interference caused by variable speed controllers,
 - resistance to the emissions of walkie-talkies conforming to IEC 61004-3.
- Light interference at a low angle of incidence in relation to the optical axis. The products in the XUSL range are resistant in accordance with IEC 61496-2

Light curtain application and installation

Using mirrors

Using Mirrors

It is important to comply with the minimum safety distances throughout the protected area, and around the perimeter where the light curtain beams are being reflected by the mirrors. The distances relating to reflective surfaces must also be calculated and observed.

The use of mirrors will significantly reduce the sensing distance of any light curtain. Each mirror used will further reduce the sensing distance.

Reminder: any contamination on the mirror surfaces, such as dust or dirt, will further reduce the sensing distance. This should be considered when installing a light curtain with mirrors in an area where there will be dust, dirt or other contaminants. More frequent cleaning of the light curtain lenses and the mirrors may be required.

Mirror Configurations

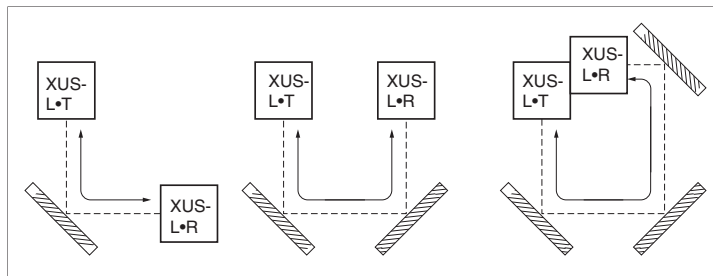

The total nominal range between the transmitter (XUSL•T) and the receiver (XUSL•R) will be reduced according to the number of deflecting mirrors.

Recommended Maximum Range for Glass Mirrors—XUSLB/XUSLD

No. of Mirrors	XUSLB/XUSLDM Range			
	3 m (9.84 ft)	7 m (21.34 ft)	8 m (26.25 ft)	20 m (60.96 ft)
1	2.6 m (8.66 ft)	6.2 m (18.78 ft)	7.0 m (23.50 ft)	17.6 m (53.64 ft)
2	2.3 m (7.61 ft)	5.4 m (16.52 ft)	6.2 m (20.30 ft)	15.4 m (46.94 ft)
3	2.0 m (6.69 ft)	4.8 m (14.54 ft)	5.5 m (17.90 ft)	13.6 m (41.45 ft)
4	1.8 m (5.91 ft)	4.2 m (12.80 ft)	4.8 m (15.75 ft)	12.0 m (36.58 ft)

Recommended Maximum Range for Stainless Steel Mirrors—XUSLB/XUSLD

No. of Mirrors	XUSLB/XUSLDM Range			
	3 m (9.84 ft)	7 m (21.34 ft)	8 m (26.25 ft)	20 m (60.96 ft)
1	2.5 m (8.07 ft)	5.7 m (17.50 ft)	6.6 m (21.50 ft)	16.4 m (49.99 ft)
2	2.0 m (6.63 ft)	4.7 m (14.35 ft)	5.4 m (17.60 ft)	13.4 m (40.84 ft)
3	1.7 m (5.41 ft)	3.9 m (11.76 ft)	4.9 m (14.50 ft)	11.0 m (33.53 ft)
4	1.4 m (4.46 ft)	3.2 m (9.65 ft)	3.6 m (11.90 ft)	9.0 m (23.43 ft)

Note: When mirrors are used, the effects of vibration will be more noticeable. Proper alignment may require more time in the set-up of the light curtain and the associated mirrors. The mirrors must be firmly and securely mounted and be protected from shock, vibration, and other physical damage.

Light curtain application and installation

MOS and protected height

Minimum Object Sensitivity (MOS)

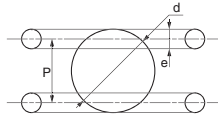

This is the smallest diameter (object) which a Type 4 security light curtain is capable of detecting.

$$d = P + e$$

d: minimum object sensitivity

P: distance between the axes of 2 adjacent beams

e: diameter of the beams

XUSL range	P in. (mm)	e in. (mm)	d in. (mm)
Finger protection	0.30 in. (7.5 mm)	0.26 in. (6.5 mm)	0.55 in. (14 mm)
Hand protection	0.63 in. (16 mm)	0.59 in. (15 mm)	1.18 in. (30 mm)

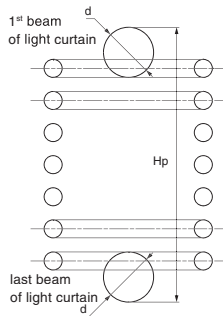

Protected Height (HP)

According to EN 61496, this is the zone (or height) within which an object of equal diameter to the minimum object sensitivity d is always detected.

Test Rod

A test rod is included with each XUSL light curtain for the purposes of periodically testing the light curtain for proper operation. A test rod is the appropriate diameter for testing the light curtain it was shipped with.

Light curtain application and installation

Blanking

Blanking

ECS (Blanking)

The blanking feature, or Exact Channel Select (ECS), can be used as an option to disable selected beams or channels in the safety light curtain's sensing field. This option is accomplished by blocking the beams or channels at fixed locations in the sensing field. This feature is used when stationary objects, such as fixtures, conveyors, or tooling, obstruct fixed areas of the sensing field. Once the specific beams or channels have been blocked and the blanking feature has been activated, the selected beams must remain blocked. If the obstruction is removed, the light curtain will transmit a stop signal to the machine.

Floating Blanking

Floating blanking is an option for use with ECS (blanking) or as a stand alone feature. Floating blanking provides the ability for up to two beams or channels to be disabled at any position in the sensing field. The two beams or channels disabled with this feature are not fixed at a single position; they are allowed to float through the sensing field.

It is important to follow the instruction manual provided with the safety light curtain when using the ECS (blanking) and floating blanking optional features together.

If the ECS (blanking) or floating blanking feature is active, the minimum safe distance is affected by an increase in the light curtain's minimum object sensitivity (MOS). According to the ANSI safety distance formula, if the object sensitivity of the light curtain increases, the minimum safe distance must increase.

Protection for the Functions of Blanking and Floating Blanking

The functions of ECS/blanking and floating blanking create "holes" in the detection zone. These holes are required for certain applications. If an obstruction does not completely fill these holes one of two actions will be required:

- The safe mounting distance will need to be increased to account for the larger opening in the detection zone.
- The area not filled by an obstruction must be guarded, typically by some method of hard guarding.

Hard guarding refers to mechanical barriers such as sheet or expanded metal.

Light curtain application and installation

Test procedure

Test Procedure

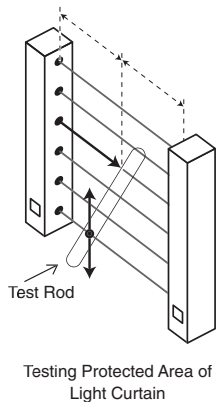

Test Procedure for the United States

The tests below must be performed by qualified personnel (per ANSI B30.2—1993) at or after the following:

- After installation and before the machine is commissioned,
- At regular inspections determined by the employer,
- After any maintenance, adjustment, or modification to the light curtain or machine,
- After tooling or fixture changes.

We also recommend that the following test procedure be performed daily or at each shift change.

Test procedure:

1. Turn off the machine. Turn on the light curtain.
2. Check the machine to make sure that all guarding is firmly in place, operates properly, and the only access to the hazardous area is through the area protected by the light curtain.
3. Check that light curtain mounting meets or exceeds the minimum safety distance from the nearest hazardous area (pinch point). Verify that the light curtain is mounted securely to a rigid mounting surface.
4. Check for damage to mounting brackets, mounting surface, wiring, or mirrors (if used). If any damage is found, the machine should be locked out ▲ until it is repaired.
5. Verify that operators cannot position themselves between the hazardous area (pinch point) and the light curtain. If this is possible, additional guarding must be installed.
6. Check the distance between the hazardous area and the light curtain sensing area to verify that it meets or exceeds the minimum safety distance.
7. Insert the test rod (the round rod included with each XUSL light curtain) into the protected (sensing) area, and move the test rod throughout the entire protected area (top, bottom, sides, vertically up & down in the middle of the sensing area).
8. Remove the test rod and start up the machine. With the machine running, insert the test rod into the sensing area and verify that the machine stops immediately.
9. With the test rod still in the sensing area, verify that the machine cannot be restarted.
10. Remove the test rod from the sensing area and verify that the machine cannot be restarted except when the proper start-up sequence has been followed.
11. Check the stopping mechanisms (including brakes) to verify proper working condition.
12. If any of the above tests do not give the indicated results, the machine should be locked out ▲ until it is repaired. Then run the above tests again.

▲ Follow OSHA 1910.147 for lock-out/tag-out procedures

Applications	Cable Pull switches for: - conveyor systems - materials handling - machine tools - electrical testing stations
---------------------	---



Features	For cable lengths up to 165 ft (50 m). Can be tripped by the operator at any point in the work zone	For cable lengths up to 50 ft (15 m). Can be tripped by the operator at any point in the work zone
Conformity to standards	XY2CE: EN/IEC 60947-5-1, EN/ISO 13850:2006, UL 508 and CSA C22-2 n° 14 (when specified H7)	XY2CH: EN/IEC 60947-5-1, EN/ISO 13850:2006, UL 508 and CSA C22-2 n° 14 (when specified H7)
Protective treatment	Special version, "TK"	Special version, "TK"
Ambient temperature		
Operating	-13 to +158 °F (-25 to +70 °C)	-13 to +158 °F (-25 to +70 °C)
Storage	-40 to +158 °F (-40 to +70 °C)	-40 to +158 °F (-40 to +70 °C)
Electric shock protection conforming to EN/IEC 61140	Class I	Class I
Degree of protection conforming to EN/IEC 60529	XY2CE: IP 65	XY2CH: IP 65
Positive operation conforming to EN/IEC 60947-5-1 Appendix K	N.C. contacts with positive opening operation ⊖	N.C. contacts with positive opening operation ⊖
Rated insulation voltage	Ui = 400 V degree of pollution 3 conforming to EN/IEC 60947-1, Ui = 300 V conforming to UL 508, CSA C22-2 n° 14	Ui = 400 V degree of pollution 3 conforming to EN/IEC 60947-1, Ui = 300 V conforming to UL 508, CSA C22-2 n° 14
Rated impulse withstand voltage conforming to EN/IEC 60947-1	Uimp = 4 kV	Uimp = 4 kV
Catalog numbers	XY2CE	XY2CH
Pages	7/71	7/72

7



XY2CE1A196H7

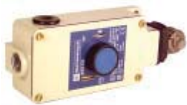

XY2CH13150H7

Operating Principle

XY2 Cable Pull Switches provide for a stop or emergency stop to be signaled at any point along a cable up to 165 feet (50 m) in length. This is many times preferred to installing many individual stop or emergency stop push button stations along a conveyor or around the machine, providing a more cost effective solution. Typical applications include conveyor systems, packaging, textiles, transfer machines, presses, woodworking equipment, paint lines, and test laboratories.

The cable pull switch is typically mounted at one end of a machine or conveyor, and the operating cable is routed along the conveyor or around the machine and secured at the other end. The operation of the XY2 is based on the taut cable principle—the cable must be tight and have appropriate tension applied to set or reset the switch. Once cable tension has been set, the device will open the N.C. control contacts if the cable is pulled or if it becomes slack due to stretching or breakage of the cable. Once the switch is tripped, it must be manually reset.

Two versions are available:

- Emergency stop versions have positive opening N.C. contacts that latch upon tripping (positive opening) and must be manually reset.
- Normal stop versions are used where a momentary, non-emergency signal is required at any point along a cable. These devices have snap acting contacts and are non-latching devices.

Features Include:

3 cable entries 1/2" NPT	Manual tripping force adjustment (XY2CE)
Positive latching (no teasing)	Adjustment indicator
Slow-make slow-break for emergency stop	UL Listed and CSA Certified
Snap action contacts for momentary switch	XY2CH for applications up to 50 feet (15m)
Works properly even if spring is broken	XY2CH has two viewing windows to aid in setting and adjusting the switch
Padlock attachment	XY2CE for applications up to 165 feet (50m)
Doesn't reset if out of adjustment	Positive opening N.C. contacts meets the IEC and EN requirements for positive opening contacts per IEC/EN 60947-5-1; and NEMA ICS-5, part 6 (direct opening action).

The use of an end spring is strongly advised when using cable pull devices on continuous duty mechanical handling equipment and systems.

The following standards allow the use of cable pull (pull cord) devices in e-stop circuits:

IEC 60204-1: 10.7 AND 10.8	ISO 13850	NFPA 79 (2002): 10.7.2
----------------------------	-----------	------------------------

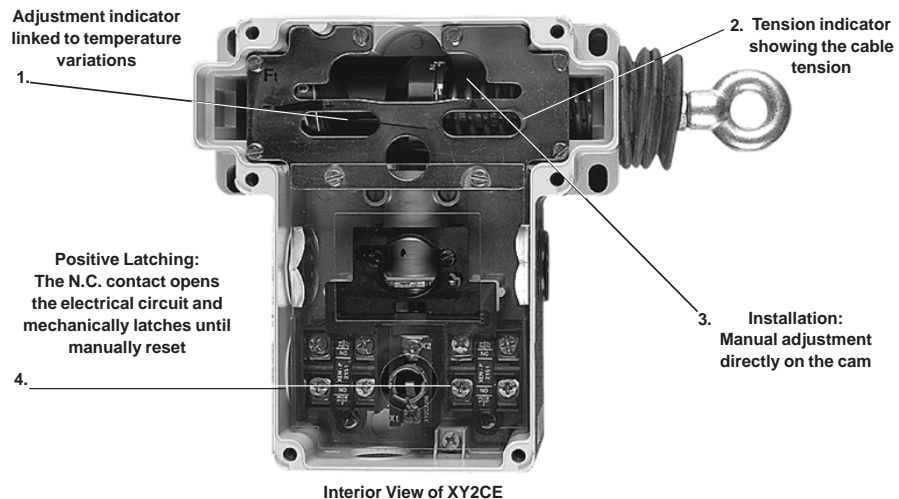

Specifications

Conformity to Standards Approvals	ANSI A 17.1, IEC 60947-5-1, EN 60204-1, NFC 79-130, NFC 63144, VDE 0660-207. XY2CE and XY2CH: UL Listed and CSA Approved.
Ambient Temperature	Operation: from -13 °F to +158 °F (-25 °C to +70 °C) for standard devices; -40 °F to 158 °F (-40 °C to +70 °C) for TK (corrosion proof) versions. Storage: from -40 °F to +158 °F (-40 °C to +70 °C) for all devices. The minimum temperatures listed are based on the absence of freezing moisture or water. ▽
Vibration Resistance	XY2CE: 10G (10 to 300 Hz). XY2CH: 10G (10 to 150 Hz), conforming to IEC 68-2-6
Shock Resistance	50G, duration 11 ms, conforming to IEC 60068-2-27
Electric Shock Protection	UL 508, 19-1, Class I conforming to IEC 60536 and NF C 20-030.
Enclosure Rating	Type 1, 4, 12. IP 65 conforming to IEC 60529, IP 657 conforming to NF C 20-010 (IP 667 with booted push button).
Mechanical Life	10,000 operations for emergency stop; 100,000 operations for normal stop
Cable Entry	3 x 0.5" NPT
Operating Position	All positions.
Length of Protected Area	XY2CE: maximum 165 ft (50m). XY2CH: maximum 50 ft (15m)

▽ The minimum temperatures listed are based on the absence of freezing moisture or water. Care should be taken to avoid sub-freezing temperatures where dripping or splashing water is present and to avoid bringing a cold device into a humid atmosphere and then back into sub-freezing temperatures. The water or moisture may freeze around internal or external components and prevent it from performing as intended.

Electrical Specifications

Rated Thermal Current	10A conforming to UL 508, CSA C 22-2 N° 14, IEC/EN 60947-5-1, NFC 63140, VDE 0660-200.
Rated Insulation Voltage	300 Vac and Vdc conforming to UL 508, CSA 22-2 N° 14. 500 V conforming to IEC 158-1, NFC 20-040; 300 V conforming to VDE 0660-207.
Contact Operation	SPDT Slow-make slow-break, positive opening operation contacts for emergency stops. ♦ SPDT Snap action for normal stops without mechanical latching.
Resistance Between Terminals	25 mΩ
Terminal Referencing	13-14 normally open, 21-22 normally closed (conforming to CENELEC EN 50013).
Voltage Range	24 to 380 V
Wiring Terminals	Screw clamp terminals. Min: 1#20 AWG (1 x 1.05 mm ²), Max: 2#16 AWG (2 x 1.5 mm ²)
Recommended Terminal Clamp Torque	7.0 in.lbs. (0.8 N*m)
Short Circuit Protection Δ	In U.S. use fast action fuse 10A type SC; form I Class J, H or equivalent. 10A cylindrical fuses type g1 or N conforming to IEC 337-1B- and VDE 0660-200
Contact Rating	Utilization category A300 and Q300. Operating rate: 3600 operations/hour. Load factor: 0.5.
Minimum Contact Rating	15 Vdc, 2mA (based on clean environment)
Rated Power	Conforms to IEC/EN 60947-5-1, duty categories AC 15 and DC 13. Operating rate: 3600 operations per hour. Load factor: 0.5

- ♦ Positive opening N.C. contacts meet the IEC and EN requirements for positive opening contacts per IEC/EN 60947-5-1; and NEMA ICS-5, part 6.
- Δ The use of the recommended fuse is mandatory for emergency stop applications. Without a fuse to protect the circuit, the contacts may develop a weld significant enough that the positive opening contact mechanism may not be able to break through the weld.

AC Voltage and Current Ratings 50–60 Hz

Contact Rating Designation	Thermal Continuous Test Current, Amperes	Maximum Current, Amperes								Voltamperes	
		120 V		240 V		480 V		600 V		Make	Break
A300	10	60	6.00	30	3.00	–	–	–	–	7200	720

DC Voltage and Current Ratings

Contact Rating Designation	Thermal Continuous Test Current, Amperes	Maximum Make or Break Current, Amperes			Make or Break at 300 Volts or Less, Voltamperes
		125 V	250 V	301 to 600 V	
Q300	2.5	0.55	0.27	–	69

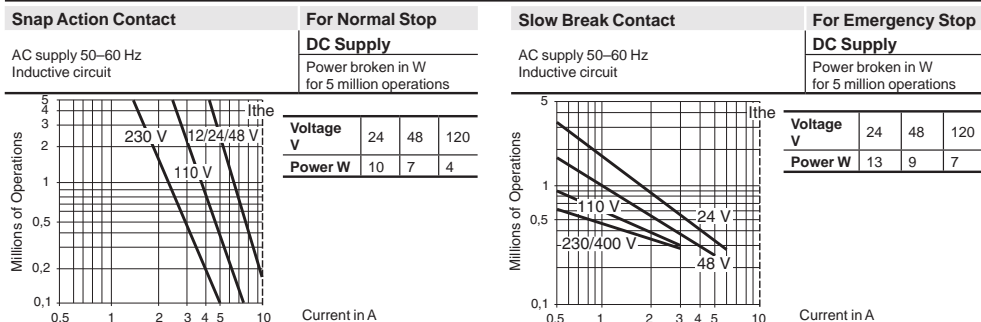

The product life expressed above is based on average usage and normal operating conditions. Actual operating life will vary with conditions. The above statements are not intended to nor shall they create any express or implied warranties as to product operation or life. For information on the limited warranty offered on this product refer to the Square D terms and conditions of sale found in the *Digest*.

XY2CE Cable Pull for up to 165 ft (50 m) cable length

Cable and accessories must be selected and ordered separately from pages 7/73 and 7/74.



Right Cable Mount



Left Cable Mount

Emergency Stop

Emergency Stop (Latching contact—reset by push button—positive * opening contacts)
Available only with slow break contacts.

The N.O. contacts close after the N.C. contacts open. They do not change state simultaneously.

The N.C. contacts only should be used in the safety control circuit. The N.O. contacts are provided solely for signaling—NOT for safety functions.

To conform with ISO 13850 of the European Union Machinery Directive, safety circuits must use emergency stop devices with 2 N.C. contacts in category 3 or 4 safety control systems. Using devices with 1 N.O. and 1 N.C. contact will not allow the system to meet category 3 or 4 as it would not meet the requirements for redundancy. Cable pull switches with 1 N.O. and 1 N.C. contact would be suitable for Category B, 1 or 2 safety control systems. XY2 cable pull switches are ideal choices for use with Preventa® XPS safety relays.

Reset	Contact	Pilot light (available only on 2 N.O.—2 N.C. devices)	Catalog Number
Right cable mount			
Standard push button	N.O. + N.C.	No	XY2CE1A150H7
Booted push button ▽	N.O. + N.C.	No	XY2CE1A250H7
Standard push button	2 N.O. + 2 N.C.	No	XY2CE1A190H7
Standard push button	2 N.O. + 2 N.C.	Yes ♦	XY2CE1A196H7
Booted push button ▽	2 N.O. + 2 N.C.	No	XY2CE1A290H7
Booted push button ▽	2 N.O. + 2 N.C.	Yes ♦	XY2CE1A296H7
Left cable mount			
Standard push button	N.O. + N.C.	No	XY2CE2A150H7
Booted push button ▽	N.O. + N.C.	No	XY2CE2A250H7
Standard push button	2 N.O. + 2 N.C.	No	XY2CE2A190H7
Standard push button	2 N.O. + 2 N.C.	Yes ♦	XY2CE2A196H7
Booted push button ▽	2 N.O. + 2 N.C.	No	XY2CE2A290H7
Booted push button ▽	2 N.O. + 2 N.C.	Yes ♦	XY2CE2A296H7

- ▽ Recommended for outdoor applications where icy conditions are likely.
- ♦ Bulb not included. See spare parts list on page 7/73. For 220 V Δ change last digit to 7, bulb included.
- * Positive opening N.C. contacts meet the IEC and EN requirements for positive opening contacts per IEC/EN 60947-5-1; and NEMA ICS-5, part 6 (direct opening action).

Normal Stop

Normal stop Δ (momentary action, no reset, no positive * opening contact)

Available only with snap action contacts. Not for use in safety circuits.

	Contact	Pilot Light (only available on 2 N.O.-2 N.C. devices)	Catalog Number
Right cable mount	N.O.+N.C.	No	XY2CE3A010H7
	2 N.O.+2 N.C.	No	XY2CE3A020H7
	2 N.O.+2 N.C.	Yes ♦	XY2CE3A026H7
Left cable mount	N.O.+N.C.	No	XY2CE4A010H7
	2 N.O.+2 N.C.	No	XY2CE4A020H7
	2 N.O.+2 N.C.	Yes ♦	XY2CE4A026H7

- ▽ Recommended for outdoor applications where icy conditions are likely.
- ♦ Bulb not included. See spare parts list on page 7/73. For 220VΔ change last digit to 7, bulb included.
- * Positive opening N.C. contacts meet the IEC and EN requirements for positive opening contacts per IEC/EN 60947-5-1; and NEMA ICS-5, part 6 (direct opening action).

Options for XY2CE

Description	Designator
Corrosion resistant (only available on devices with booted push button on Emergency Stop devices and all Normal Stop devices) Not available on key operated emergency stop reset nor mushroom head reset versions. The enclosure color is olive-blue instead of beige.	Provides a silicone boot, special finish, and copper/brass eyelet. -For non-pilot-light devices: 1. Add suffix TK to the part number 2. Change A to C Example: XY2CE1A250H7 changes to XY2CE1C250H7IK -For pilot light devices: 1. Add suffix TK to the part number 2. Change A to E Example: XY2CE1A296H7 changes to XY2CE1E296H7IK
Low Temperature -40 °F (-40 °C) The minimum temperatures listed are based on the absence of freezing moisture or water.	Non-pilot-light versions -Change A to C: silicone boot Ex: XY2CE1A150H7 changes to XY2CE1C150H7 Pilot light versions -Change A to E: silicone boot Ex: XY2CE1A196H7 changes to XY2CE1E196H7
N.C. + N.C. contact	-Change the 9th digit to 7 (for emergency stop only) Ex: XY2CE1A150H7 changes to XY2CE1A170H7
Mushroom head reset	-Change the 8th digit to 3 Ex: XY2CE1A150H7 changes to XY2CE1A350H7
Key operated emergency stop reset (Uses Ronis key No. 421)	-Change the 8th digit to 4. Ex: XY2CE1A150H7 changes to XY2CE1A450H7

Δ These devices or components are not UL/CSA.

Acceptable Wire
Sizes 14-24 AWG
Recommended Terminal
Clamp Torque 13 lb-in





XY2CH13150

XY2CH Cable Pull for up to 50 ft (15 m) cable length

Cable and accessories must be selected and ordered separately from pages 7/73 and 7/74.

Emergency Stop

Emergency Stop (Latching contact—reset by push button—positive * opening contacts)
Available only with slow break contacts.

The N.O. contacts close after the N.C. contacts open. They do not change state simultaneously.

Only the N.C. contacts should be used in the safety control circuit. The N.O. contacts are provided solely for signaling—NOT for safety functions.

To conform with ISO 13850 of the European Union Machinery Directive, safety circuits must use emergency stop devices with 2 N.C. contacts in category 3 or 4 safety control systems. Using devices with 1 N.O. and 1 N.C. contact will not allow the system to meet category 3 or 4 as it would not meet the requirements for redundancy. Cable pull switches with 1 N.O. and 1 N.C. contact would be suitable for Category B, 1 or 2 safety control systems. XY2 cable pull switches are ideal choices for use with Preventa® XPS safety relays.

Reset	Contact	Pilot Light	Catalog Number
Standard push button	N.O. + N.C.	No	XY2CH13150H7
Booted push button ▽	N.O. + N.C.	No	XY2CH13250H7
Mushroom head push button	N.O. + N.C.	No	XY2CH13350H7
Key operated emergency stop (uses Ronis Key No. 421)	N.O. + N.C.	No	XY2CH13450H7

Normal Stop

Normal stop Δ (momentary action, no reset, no positive * opening contacts)

Available only with snap action contacts. Not for use in safety circuits.

Reset	Contact	Pilot Light	Catalog Number
No Reset Required	N.O. + N.C.	No	XY2CH33010H7

▽ Booted push button recommended for outdoor applications where icy conditions are likely.

* Positive opening N.C. contacts meet the IEC and EN requirements for positive opening contacts per IEC/EN 60947-5-1, and NEMA ICS-5, part 6 (direct opening action).

Δ Normal stop devices are not UL/CSA.

Options for XY2CH

Description	Designator
Corrosion resistant (only available on devices with booted push button on Emergency Stop devices and all Normal Stop devices). Not available on key operated emergency stop reset or mushroom-head reset versions. The enclosure color is olive-blue instead of beige.	Provides a silicone boot and special finish: 1. Add suffix TK to the catalog number 2. Change the seventh character to 4 Example: XY2CH13250H7 changes to XY2CH14250H7TK
Silicone bellows	-Change the 7th digit to 4 Ex: XY2CH13150H7 changes to XY2CH14150H7
N.C. + N.C. contact	-Change the 9th digit to 7 (for emergency stop only) Ex: XY2CH13150H7 changes to XY2CH13170H7
Pilot light (not UL/CSA) Bulb is included, replacement bulbs available on page 7/73	- For 24 V, change the 10th digit to 3 - For 48 V, change the 10th digit to 4 - For 120 V, change the 10th digit to 5 - For 230 V, change the 10th digit to 7 Ex: XY2CH13150H7 changes to XY2CH13153H7

Acceptable Wire
Sizes 14-24 AWG
Recommended Terminal
Clamp Torque 13 lb-in



XY2CE Accessories



XY2CZ702 XY2CZ404



XY2CZ203 XY2CZ917



XY2CZ906 ZB2BV04



DL1CE024 XY2CZ901



XY2CZ0130H4



XY2CZ902

Description	Sold in lots of	Catalog Number
End spring for cables longer than 83 ft (25m) * Can also be used on shorter length cables.	1	XY2CZ702
Padlock attachment (Yellow) Contains padlock attachment and two tamper proof cover mounting screws with special key	1	XY2CZ916
Turnbuckle to tighten actuating cable. Threaded eye bolt is M8 x 70 + locknut	1	XY2CZ404
Tensing device. Used instead of a turnbuckle, provides for easy adjustment right on the switch.	1	XY2CZ203
Tensing device + support. Used instead of a turnbuckle, provides for easy adjustment right on the switch, and also provides the first cable support for the actuating cable.	1	XY2CZ917

XY2CE Spare Parts

Description	Sold in lots of	Catalog Number	
Pilot light body	Direct voltage to 130 V, bulb not included Direct voltage for 230 V, bulb not included	1 1	XY2CZ906 XY2CZ907
Pilot light head		1	ZA2BV04
BA9s incandescent bulb	24 V, 2.6 W	1	DL1CE024
	48 V, 2.6 W	1	DL1CE048
	130 V, - 2.6 W ★	1	DL1CE130
Dust and damp protecting bellows	Polychloroprene (std.)	1	XY2CZ901
	Silicone	1	XY2CZ904

★ This lamp is used in both 120 V and 230 V applications. For 230 V application, a pilot light body with resistor (XY2CZ907) is used in the switch.

XY2CH Accessories

Description	Sold in lots of	Catalog Number	
End spring *	1	XY2CZ703	
Pilot light Yellow (Not UL/CSA)	24 V	1	XY2CZ0024H4
	48 V	1	XY2CZ0048H4
	120 V	1	XY2CZ0130H4
	220-240 V	1	XY2CZ0230H4

XY2CH Spare Parts

Description	Sold in lots of	Catalog Number	
Dust and damp protecting bellows	Polychloroprene (std.)	1	XY2CZ902
	Silicone	1	XY2CZ903
Pilot light bulb Screw fitting for XY2CH Max. diameter 17 mm Length 34 mm	24 V, 6 W	10	DL1AA024
	48 V, 6 W	10	DL1AA048
	130 V, 6 W	10	DL1AA127
	230 V, 6 W	10	DL1AA220

* The use of an end spring is strongly advised when using cable pull devices on continuous duty mechanical handling equipment and systems.



Accessories (suitable for both XY2CE and XY2CH)

Description	Sold in lots of	Catalog Number
Cable kits		
34.4 ft (10.5 m) (For use with XY2CH)	1	XY2CZ9310
83.7 ft (25.5 m) (For use with XY2CE in medium length applications)	1	XY2CZ9325
165.6 ft (50.5 m) (For use with XY2CE in maximum length applications)	1	XY2CZ9350
Galvanized steel cable with red jacket 1/8 in. (3.2 mm) diameter. The red cable jacket meets EN requirements for emergency stop actuators to be red.	Length 34.4 ft (10.5 m)	1 XY2CZ301
	Length 83.7 ft (25.5 m)	1 XY2CZ302
	Length 165.6 ft (50.5 m)	1 XY2CZ305
Cable clamps	Single; 0.138 in. (3.5 mm) diameter cable (max.)	10 XY2CZ503
	Double; 0.138 in. (3.5 mm) diameter cable (max.)	10 XY2CZ513
	Clamp; 0.138 in. (3.5 mm) diameter cable (max.)	10 XY2CZ523
Cable support	Fixed (5/16 in. coarse thread, 0.35 in. deep)	10 XY2CZ601
	Swiveling	1 XY2CZ602
	Pulley support (to be used with Pulley XY2CZ708)	1 XY2CZ705
Pulley, 0.2 in. (5 mm) max. diameter cable (to be used with XY2CZ705 Pulley Support)	1	XY2CZ708
Wire and protective guard for 0.118–0.138 in. (3–3.5 mm) diameter cable. Guard is used to protect cable when securing to the switch, turnbuckles, and end springs, etc. The cable is placed in the groove of the guard so the guard comes in contact with the switch, turnbuckle, or end springs—instead of the cable itself. Reduces stress and strain on cable.	10	XY2CZ701

* The use of an end spring is strongly advised when using the cable pull devices on continuous duty mechanical handling equipment and systems.

Spare Parts (suitable for both XY2CE and XY2CH)

Description	Sold in lots of	Catalog Number
Contact block	Slow break, N.O. + N.C. (emergency stop)	0 Not available separately
	Slow break, N.C. + N.C. (emergency stop)	0 Not available separately
	Snap action, N.O. + N.C. (normal stop)	1 XESP2151
Reset operators	Flush with marking R	1 ZA2BA639
	Booted	1 ZA2BP6
	Emergency stop head 30 mm diameter, blue	1 ZA2BC64
	Key operated emergency stop, blue (Ronis Key No. 421)	1 ZA2BS06212
Key	Ronis No. 421	1 Q99900911

7



XY2CH

Without pilot light

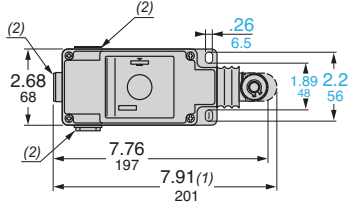

With pilot light

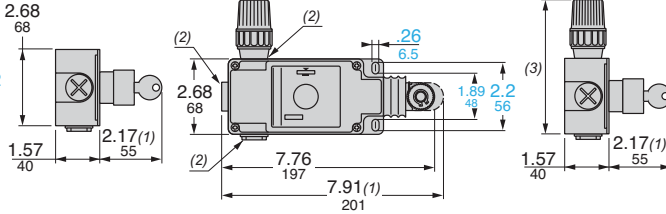

Accessories

XY2 CZ705

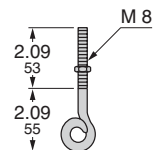

XY2 CZ708

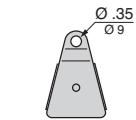

(1) Maximum extension.
 (2) 4.76 in. (121 mm): 24 V and 48 V versions. 5.16 in. (131 mm): 130 V and 230 V versions.

XY2CE

XY2CE●A●●●, XY2CE●C●●●

XY2CE●A●●● + XY2 CZ917 (tensioner + bracket)

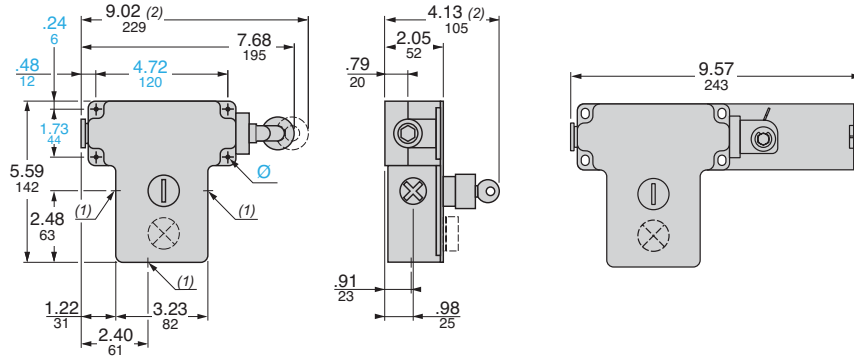

(2) Maximum extension.
 Ø: 4 elongated holes Ø 0.24 in. (6 mm).

Dual Dimensions: Inches
 Millimeters

XY2CE Operating Principles

Note: An end spring (8) is recommended at the far end of the cable (1) allowing the cable to be moved right or left, especially for cables 80 ft or longer. The use of an end spring is strongly advised when using the cable pull devices on continuous duty mechanical handling equipment and systems.

Normal Position

The cable (1) is tightened by the turnbuckle (2) and held in a normal position by the spring (3). As the turnbuckle is turned, the cam (4) moves from left to right, and allows the actuator (5) to be positioned according to the particulars of the desired setting (see page 7/80).

The mechanical latch is unlocked when the N.C. contact is in the locked position.

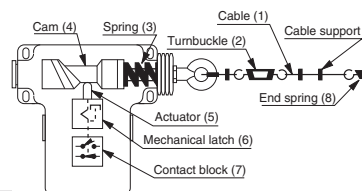

Tripping the Device

Operating or breaking the cable results in the cam shifting position.

The active part of the cam presses down the actuator (5), simultaneously causing the N.C. contact (7) to open and the mechanical latch (6) to maintain it in its open position. Cable supports ensure the transmission of the cable tension into the axis of the switch cam.

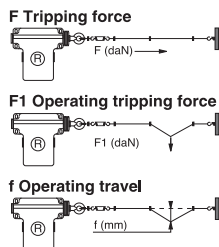

Definitions

The value of the **tension (F) along the cable** which trips the switch. Adjustable value according to cam position (see table on page 7/77).

The value of the **traction force (F1)** applied by the operation **perpendicular to the cable** which trips the switch. Adjustable value according to the table on page 7/77.

The distance (f) traveled by the operator (i.e., the operator's hand), between the normal position and the tripping point. Adjustable value according to the table on page 7/77.

General Purpose Adjustment Method

XY2CE—Cable Traction Force

Adjust either directly when mounting the cable or using a turnbuckle positioned near the switch but **after the first cable support**. For standard adjustment the **tension indicator should be in the middle of the range**.

Operating Travel

The tripping point is adjusted by the rotating cam marked by letters A to F. Position A corresponds to the minimum travel. Position F corresponds to the maximum travel.

NOTE: The switches are delivered from the factory in position A.

XY2CH

XY2CH has two viewing windows to aid in adjusting cable tension and resetting the switch. When the cable tension indicator is in mid-range in its viewing window, the reset button should be pushed to reset the device. When reset, a green indicator is visible in the contact viewing window. When the switch is tripped, a yellow indicator is visible in the contact viewing window and the cable tension indicator is at the edge of its viewing window.

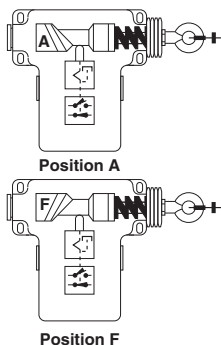

XY2CE Specific Adjustment Method

When the travel or tripping force is specified, the cable tension and the cam position should be adjusted based on the values below. (Refer to General Purpose Adjustment Method on page 7/76.)
For each position of the cam, the values of the operating travel and force (F1) corresponding to the minimum and maximum cable tension are tabulated below.

Cable characteristics: length = 165 ft (50 m); maximum elongation of cable must be no more than 0.00834 in./ft (0.7 mm/m), equivalent to a maximum co-efficient of expansion of 0.07%, based on a 108 °F (60 °C) temperature variance.

Switch Type	Cam Position		Cable Tension (Axial)		2 m Between Supports		5 m Between Supports				Tripping Force (Axial)			
			F		f		F1		f		F1			
			N	lb-f	mm	in.	N	lb-f	mm	in.	N	lb-f	N	lb-f
XY2CE	A	Min.	145	32.6	94.0	3.7	59	13.2	160	6.30	20	4.5	323	72.7
		Max.	195	43.9	81.3	3.2	57	12.8	160	6.30	32	7.2		
	B	Min.	150	33.8	104.1	4.1	83	18.7	170	6.69	24	5.4	333	74.9
		Max.	205	46.1	91.4	3.6	76	17.1	175	6.89	38	8.6		
	C	Min.	152	34.2	114.3	4.5	90	20.2	180	7.09	28	6.3	352	79.3
		Max.	215	48.4	106.7	4.2	83	18.7	190	7.48	44	9.9		
	D	Min.	155	34.9	124.5	4.9	98	22.0	190	7.48	32	7.2	372	83.7
		Max.	225	50.6	114.3	4.5	89	20.0	200	7.87	49	11.0		
	E	Min.	160	36.0	134.6	5.3	109	24.6	200	7.87	35	7.9	402	90.4
		Max.	235	52.9	124.5	4.9	104	23.5	210	8.27	56	12.6		
	F	Min.	165	37.1	144.8	5.7	117	26.4	205	8.07	39	8.8	421	94.8
		Max.	245	55.1	134.6	5.3	111	24.9	220	8.66	60	13.5		
XY2CH	—	—	100	22.5	—	—	—	160	6.30	20	4.5	—	—	

Setup

XY2CH

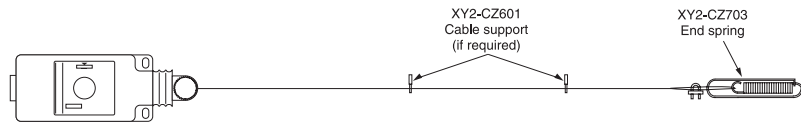

XY2CE

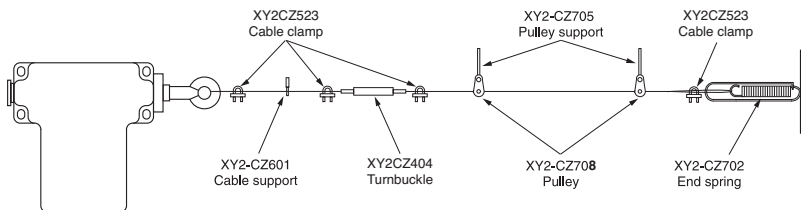

XY2CE + XY2CZ917

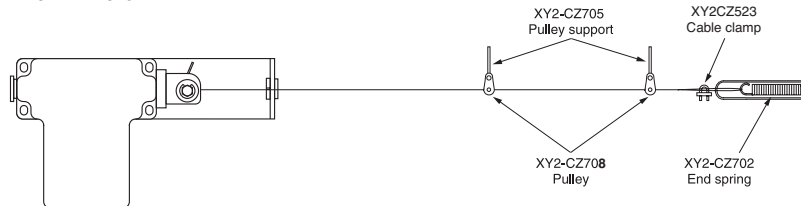

Application and Installation Recommendations

The XY2 cable pull switches are based on the taut cable principle, which means the cable must be tight and have a tension applied to allow the switch to be reset and work properly. This is different from slack cable switches where the cable is normally slack and is only tight when pulled. The benefit of the taut cable principle is that the operator knows that if the cable is taut, the machine can be shut down. If slack cable switches are used, the operator is not assured the cable is affixed properly at the switch and may be unsure that when the cable is pulled the machine will stop.

The distance an operator must pull the cable on a slack cable switch depends on the operator's distance from the switch and the amount of slack in the cable. An operator close to the switch needs to take up much less slack in the cable before tripping the switch than an operator at the far end of the installation. With a taut cable switch, the operating force and distance the cable needs to be pulled is the same throughout the installation. The taut cable style of device is more reliable in an emergency situation.

Effects of Friction

To operate properly, the cable must be tight with tension on it, and the cable must have a minimum of friction. Care must be taken in the machine design to ensure that the system avoids ANY friction between the cable on the machine parts or components, and moving parts on the machine or material handling system.

- The cable must be free of motion on its supports. It should not lay against the supports nor rub on them except when the cable is pulled by an operator.
- The cable must not have weights attached nor applied to it as a standard part of the application.
- The application must be designed to reduce friction as low as possible. This is accomplished by using reduced friction pulleys and guides.
- The cables should never be run through conduit or tubing.

Cornering

The operating cable should be installed so that the cable run is straight, but this cable can also be routed around corners using pulleys. If the cable deviates from a straight line, pulleys **must** be used. The effects of friction could be more noticeable if the cable is not installed correctly and with a minimum of friction.

- DO NOT allow the cable to turn corners or change direction using only cable supports.
- A pulley **must** be used when routing cable around corners, regardless of the angle. Use a pulley whenever direction is changed even slightly. The pulley must have freedom of movement on its mounting to maintain the self-alignment of the cable.
- If a fixed pulley is used, a cable support should be positioned within 4 in. (10 cm) of both sides of the pulley.
- The total sum of the angles for the cable bends or turns should be no more than 180°.
 - qty of two 90-degree angle turns is acceptable.
 - qty of three 60-degree angle turns is acceptable.
 - qty of three 90-degree angle turns is not acceptable.

Temperature

Note:

*Routing the cable through both hot and cold production areas with the same cable could require more frequent adjustment and **may** not allow proper adjustment throughout the production cycle.*

Example:

A cable pull switch on a production line where the product is cooked and then flash frozen in a short distance. Some sections of the cable could be very hot, and other sections very cold, and other sections at room temperature.

Temperature variations in any of these areas could affect the overall adjustment of the cable. Where such variations occur, we recommend the use of multiple cable pulls.

Temperature variations in the area where the cable pull switch is installed can affect the adjustment of the switch. The cable expands (becomes longer) when temperature increases, and contracts (shrinks) when temperature decreases. Wide temperature variations should be avoided where possible. If temperature variations are significant, the adjustment of the cable and switch must be checked at regular intervals. If the switch is not adjusted properly during installation, temperature variations could affect cable length and trip the switch without operator intervention. If this occurs, the switch needs to be readjusted.

Temperature variances can come from any of the following:

- Seasonal temperature changes in non-climate controlled areas.
- Freezers and refrigeration equipment which are cold during production but are brought to room temperature for cleaning.
- Equipment that is used to heat treat or cook material during production but is brought to room temperature for cleaning.
- Equipment which is at room temperature (or lower temperatures) for production but is cleaned with hot water or steam.
- Equipment placed near windows and large glass areas: sunlight could cause an expansion of the cable where an overcast day may cause a contraction of the cable.

General Guidelines

- Be sure the cable remains accessible and visible to the operators for its entire length.
- The switch, cable supports, and other hardware must be rigidly mounted on the machine or application. If these mountings are not secure and rigid, the tension on the cable could be changed and the switch will trip. Mounting points must not move when the cable is pulled.
- Supports are not to be placed on moveable parts of the application.
- Cable lengths used must not exceed maximum lengths listed for the particular cable pull switch.
- The turnbuckle allows for the proper adjustment of the switch, and must be mounted close to the switch to ease and simplify adjustment of the system.
- The turnbuckle locknuts should be tightened securely.
- The first cable support should be within 4 in. (10 cm) of the switch.
- The sheath around the end of the cable must be removed when inserted into the cable clamps to assure metal-to-metal contact. Failure to remove sheathing could cause the cable to slip, thus reducing cable tension, and switches may not perform to published specifications.

Wiring Diagrams

For the versions with two contact blocks, the left one is identified as A, and the right one is identified as B. The markings are permanently inscribed on the mounting fixture above the contact blocks. Ex. B 21-22 is the normally closed contact of the right contact block.

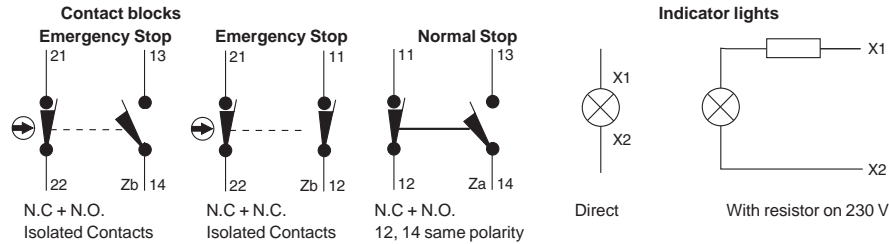

Note: When the emergency stop switch operates in conjunction with solid-state controls, e.g. PLCs, the supply for the safety functions must be disconnected independently of the PLC.

Operating instructions

Indicator Displays

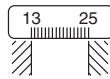

The indicators define the maximum cable tension adjustment zone. The cable tension is adjusted via the turnbuckle. **The device will not function outside this zone.** For general purpose adjustment, the indicator should be in the middle of the window.

Adjustment Limits for Effective Operating

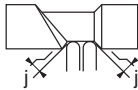

In a normal position, adjustments must be made so that there is a play (J) between the actuator and the conical parts of the cam.

Cable Supports

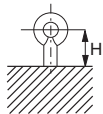
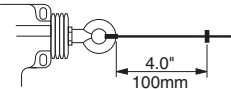

It is recommended that you space supports along the entire length of the cable at 6–16 ft (2–5 m) intervals. **Cable supports ensure the transmission of the cable tension in the axis of the switch cam. The first one after the switch is mandatory for correct operation (4.0 in., 100 mm).** Also, if pulleys are used to change the direction of the cable, **cable supports at 4 in. (100 mm) before and after the pulley are mandatory.**

Use supports with 0.8 in. (20 mm) maximum height H with respect to the product mounting surface.

Cable Characteristics

Recommended cable diameter is 1/8 in. (3.2 mm). However, any galvanized steel cable (aircraft type) less than 9/32 in. (7 mm) diameter can be used, provided it meets the following criteria: Maximum elongation of cable to be no more than 0.00834 in. per ft (0.7 mm/m), which is equivalent to a maximum co-efficient of expansion of 0.07%, based on a 140 °F (60 °C) temperature variance.