

841 PLUS® Motors

Horizontal A.C. Motors, Totally Enclosed Fan Cooled



Horsepower: 1 – 400 HP

Frame Sizes: 143 – 449

Pole Designs: 2, 4, 6, 8

Design Voltages: 460 and 575 Volts at 60 Hz

Requirements: Meets or exceeds Energy Independence and Security Act of 2007 (EISA);
Meets or exceeds IEEE 841 Standard-2009;
Meets vibration requirements of GM7E-TA

Warranty: 5-year limited warranty



Product Overview and Options

Designed to exceed the industry's most stringent IEEE 841 standards, the U.S. MOTORS® brand 841 PLUS® motors are commonly used in severe duty environments for pumps, compressors, fans, blowers, and other material processing applications. These rugged motors are ideal for constant speed or inverter duty applications typically found in the petroleum, chemical, pulp and paper, wastewater, automotive and mining industries.

U.S. MOTORS brand 841 PLUS motors are rated NEMA Premium® efficient. Low-loss silicone steel construction and streamlined design enables the motor to operate at lower temperatures resulting in lower energy costs. This motor is designed to operate in ambient temperatures of -30°C to 40°C, in altitudes of up to 1,000 meters above sea level and with NEMA Design B torque-current characteristics. Inertia-load acceleration capabilities for the 841 Plus motor meet the stringent requirements of NEMA MG 1-2009, Section 12.54.

Product Features:

- NEMA Premium® efficient
- 1.15 Service Factor on sine wave power; 1.0 Service Factor on Inverter Duty
- Class B temperature rise at 1.0 Service Factor by resistance with sine wave power
- Class F insulation materials to increase motor life
- Exceeds NEMA MG1 Part 31 Inverter Duty
- Polyurea grease
- Stainless-steel nameplate
- Variable frequency drive or full voltage, across-the-line starting
- Ground on frame

- Division 2 suitable per NEC article 500 (NFPA 70)
- AFBMA bearing numbers on nameplate
- Protective coating on each rotor and shaft from bearing journal to bearing journal

Inverter Duty

Nidec Motor Corporation's patented inverter grade insulation system allows the U.S. MOTORS brand 841 PLUS motor to withstand spike and transient voltages induced by insulated bipolar gate transistor drives, making it fully compliant with NEMA MG-1, Part 31. This is made possible through:

- Pulse-resistant magnetic wire that provides protection against high-voltage spikes
- Additional lacing on the end turns improve coil rigidity
- Multiple bake cycles to help prevent coil-to-coil circuits
- Phase paper to help prevent phase-to-phase arcs
- Adjustable frequency of 5:1 constant torque or 10:1 variable torque for the full product line.



841 PLUS®



This document provided by Barr-Thorp Electric Co., Inc. 800-473-9123 www.barr-thorp.com

Product Overview and Options *continued*

Typical 841 PLUS® Motor Construction:

1. Corrosion resistant zinc dichromate-plated hardware
2. Heavy duty cast-iron enclosure for long life and reduced vibration
3. Inverter grade insulation
4. Inpro/Seal™ “VBXX” on both ends provides IP56 protection and prolongs motor life by shielding bearings from contaminants in even the harshest environments
5. Special shaft runout of 0.0010 inches for motors 200 HP and less; runout of 0.0015 inches for motors with 250 HP and up
6. Same size oversized bearings on each end. Cast iron inner bearing caps
7. Brass breather drains
8. Oversized, double-gasketed and rotatable conduit box to protect against contaminants and correctly position non-braided, non-wicking motor leads
9. Foot flatness machined to within 0.005 inch tolerance ensures easy installation and proper alignment
10. Corrosion-resistant mill and chemical duty paint capable of withstanding a 250-hour salt spray test

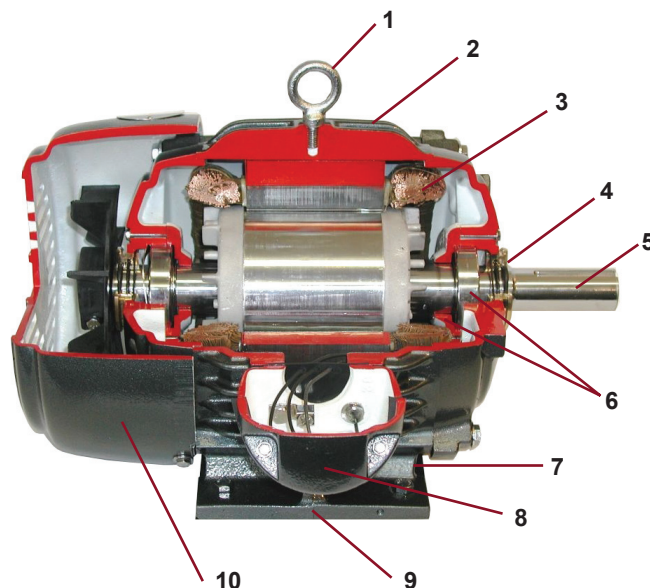

Options and Accessories

Nidec Motor Corporation offers the following custom-design options on the U.S. MOTORS brand 841 PLUS motor:

- SKF CARB™ roller bearings where applicable
- Horizontal or vertical mounting
- Vibration detectors
- Sealed insulation treatments, available on form wound, medium voltage motors above 200 HP, to help shield motor windings
- Winding and bearing thermal protection for motors 250 HP and up
- Inpro/Seal™ MGS grounding shaft rings
- API 661 Duty

Stock Motors

- 1–400 HP
- 2, 4, 6 pole designs
- 460 and 575 Volts
- Constant or variable torque
- 1–10 HP C-Face Footless

Custom and Conversion Motors

- 1–500 HP
- 2, 4, 6, 8 pole designs
- 200, 230, 460, 575, 2300, 4000 Volts
- Constant or variable torque
- C & D flange kits available 140 – 440 frame

Testing and Inspection

Nidec Motor Corporation conducts extensive testing and inspections on each of its U.S. MOTORS brand 841 PLUS motors.

- No load current, power and speed
- High-potential test on stator windings

- Insulation resistance test by megohmmeter and polarization index
- Precision balanced to typical vibration levels of less than 0.05 inches per second
- Optional complete test, including full load test

For additional information, please refer to our Full Line Standard Motor Catalog (FL600) or contact your Nidec Motor Corporation representative.

† All marks shown within this document are properties of their respective owners.
For more information about the U.S. MOTORS brand, visit www.nidec-motor.com or www.usmotors.com.

Nidec Motor Corporation, 2011; All Rights Reserved. U.S. MOTORS® is a registered trademark of Nidec Motor Corporation.
Nidec Motor Corporation trademarks followed by the ® symbol are registered with the U.S. Patent and Trademark Office.

This document provided by Barr-Thorp Electric Co., Inc. 800-473-9123 www.barr-thorp.com

Nidec
NIDEC MOTOR CORPORATION

8050 W. Florissant Avenue | St. Louis, MO 63136
Phone: 888-637-7333 | Fax: 314-553-2087