

TURCK
works

Q-track™

**LINEAR
POSITION
SENSORS**



...Sense It! ...Connect It! ...Bus It! ...Solve It!

www.turck.us

This document provided by Barr-Thorpe Electric Co., Inc. 800-473-9123 www.barr-thorpe.com

TURCK

YOUR **AUTOMATION SOLUTIONS** PROVIDER



PROXIMITY SENSORS

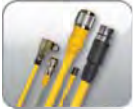

CORDSETS



DISTRIBUTED I/O



MEASUREMENT



RFID



INTERFACE MODULES



CUSTOM CONNECTIVITY



POSITION



NETWORK MEDIA

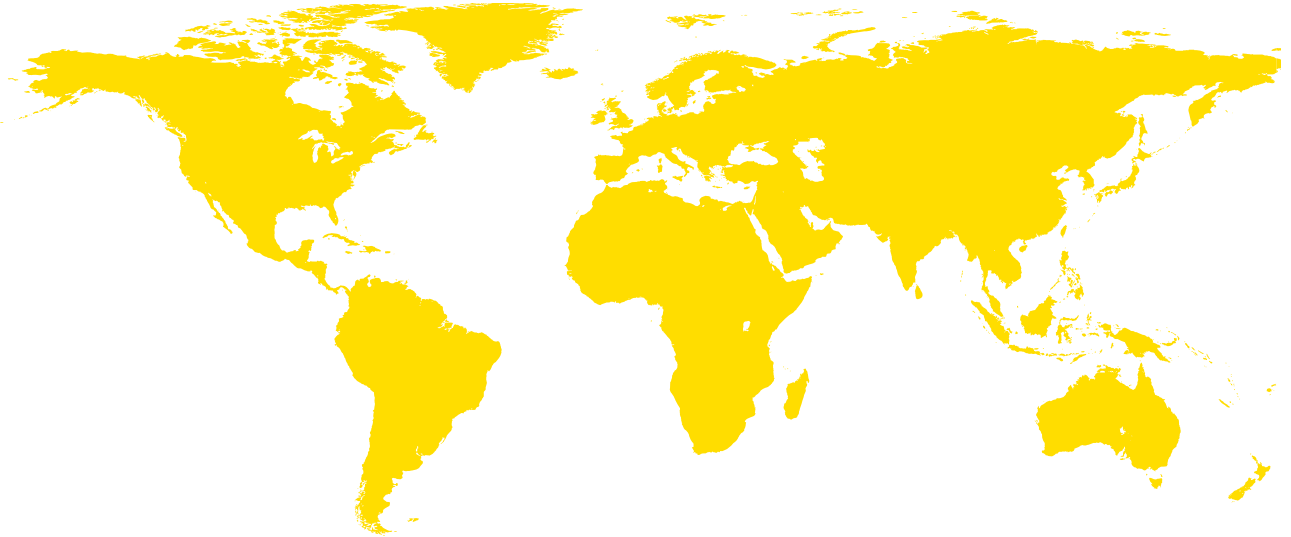

TURCK's global support network consists of over 2,500 employees in 25 countries and 60 exclusive agencies worldwide that strive to meet customer expectations. Our sales, support and manufacturing facilities are strategically located across the world allowing us to respond to local market conditions and deliver customer specific solutions on a timely basis.

We are a world leader in **automation technology** with a diverse and broad product portfolio that provides customer specific applications with high performance, reliable and cost effective solutions. The synergy in our product portfolio and customization flexibility are key components of our value proposition.

Our expertise spans across two major industry categories: **Industrial Automation** and **Process Automation**. Each weighs in with its own unique requirements and methods of conducting business. This market centric approach ensures that we develop application specific solutions across a variety of vertical market segments.



Q-track™ LINEAR POSITION SENSORS

Introduction	2
--------------	---

Q-track Linear Position Sensors

S-series with standard resolution, analog output (U/I)	4
E-series with enhanced resolution and SSI interface	6
E-series with enhanced resolution and with programmable analog/digital output (U/I, PNP), IO-Link compatible	8

Accessories

Fieldbus connection	10
Connectivity	11
Position elements	12
Mounting hardware	13

Q-track™



Q-track™ LINEAR POSITION SENSORS

BREAKING NEW GROUND

Principle of operation

TURCK's new *Q-track* linear position sensor operation is based on the RLC (Resistance Inductive Capacitance) principle and incorporates an advanced microprocessor and precisely positioned emitter and receiver coils on a printed circuit board.

The emitter coils are excited with a high frequency AC field. The interaction between the moving position element and the receiver coils creates different voltages that are induced into the receiver coils which determines the position of the target.



Speed and accuracy

To increase speed and accuracy, TURCK designed the linear position sensor with two different coil systems. The first coil system is for coarse measurements, while the second coil system is used to determine the fine position. An advanced microprocessor circuit analyzes the resulting signals producing a measuring system with very high linearity and repeatability.

The *Q-track* linear position sensor is available in 100 mm increments from 100 mm to 1,000 mm in length. Depending upon the series selected, the sensor is available with 12, 16 or 20 bit accuracy.



Short blind zones

TURCK designed the microprocessor board and coil system to be compact. The sensor length is only 58 mm longer than the measuring span. The blind zones measure a mere 29 mm on each end of the sensor. The layout of the coils is designed in such a way to minimize the effect of vertical (up to 4 mm) or lateral misalignment.



Analog or digital outputs

The standard resolution versions feature 0-10 V and 4-20 mA analog signals with 12 bit resolution, plus the flexibility of scaling or reversing the direction of operation.

The enhanced resolution versions are available in either 20 bit SSI (Synchronous Serial Interface) or 16 bit I/O Link or with configurable switching points.

A dual multifunctional Green / Yellow LED facilitates simple set up and diagnostics.





High noise immunity

The RLC circuit used in the *Q-track*™ linear position sensor is highly immune to noise interference. All products meet IEC 60529 and EN 60529 standards for noise immunity.

The *Q-track* linear position sensor is inherently weld field immune.



Robust housing

The linear position sensors have an anodized cast aluminum housing. Its electronics are mounted securely inside a polycarbonate sleeve that provides an IP67 rated housing with shock ratings up to 30g's (11 ms) and vibration resistance up to 55 Hz (1 mm displacement).

M12 *eurofast*® connectors provide an industry standard connection to the linear position sensor.

***Q-track* LINEAR POSITION SENSORS PRECISE, VERSITILE AND RUGGED**

The *Q-track* linear position sensor provides many advantages over existing linear measurement technologies, such as potentiometer and magnetostrictive devices. Potentiometer devices are larger in size relative to the measuring span and are subject to wear and contamination. Magnetostrictive transducers are also longer in length relative to the measuring span and require external magnets that are subject to environmental degradation.

TURCK's *Q-track* linear position sensor does not use magnets instead it uses a tuned coil positioning element. The *Q-track* RLC technology provides absolute position feedback and is noise immune. The 25 mm low profile housing is made from extruded materials and is IP67 rated for environmental protection. As a result, the linear position sensor may be used in a wide variety of industries and applications that require linear feedback.

- Cylinder position
- Stamping
- Pinch roll height
- Ride control
- Level control
- Flight simulators
- Pitch control
- Casting machines
- Weld nut height
- Metal cutting machinery
- Wood cutting machinery
- Plastic molding machines

Q-track™ linear position sensors

S-series with standard resolution, analog output (U/I)



Product features

- 12 bit resolution
- Current and voltage output in one device (5-wire, 15-30 VDC)
- M12 *euromast*® connector (5-pin)
- 29 mm blind zones
- Programmable measuring range
- Captive and floating (0-4 mm from sensing face) position elements available
- Robust extruded aluminum housing
- Watertight (IP67) polycarbonate insert
- Multifunction LED

Measuring range indicated via LED

- **Green:** The positioning element is in the measuring range.
- **Green/yellow alternate flashing:** The positioning element is in the measuring range with a lower signal quality (i.e. distance too long).
- **Yellow flashing:** The positioning element is outside of the measuring range (max. range).
- **Off:** The positioning element is outside the programmed range but inside the total, non-programmed measuring length.

Setting the measuring range

The initial and final value of the measuring range is set at the push of a button, either via a teach adapter or programming line (pin 5). Furthermore, the output curve can be inverted.

- Factory setting (0 V/4 mA at the connector end): Jumper pin 5 and pin 1 for 10 sec.
- Factory setting inverted: Jumper pin 5 and pin 3 for 10 sec.
- Setting the initial value: Move positioning element to desired position and jumper pin 5 and pin 3 for 2 sec.
- Setting the final value: Move positioning element to desired position and jumper pin 5 and pin 1 for 2 sec.

Part number key

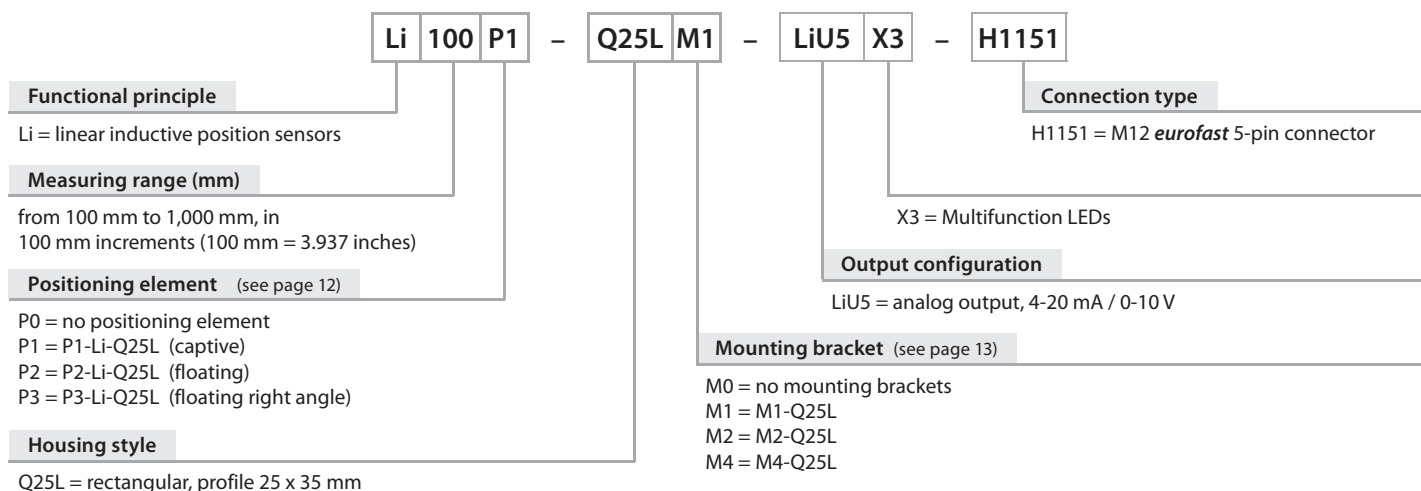

Ordering information

The *Q-track* linear position sensors are available in different lengths from 100 to 1,000 mm, in increments of 100 mm. The sensors, mounting accessories and positioning elements are available individually or as a kit.



Assembly part number:
Li200P1-Q25LM2-LiU5X3-H1151

S-series with standard resolution, analog output (U/I)

Technical data



Dimensions

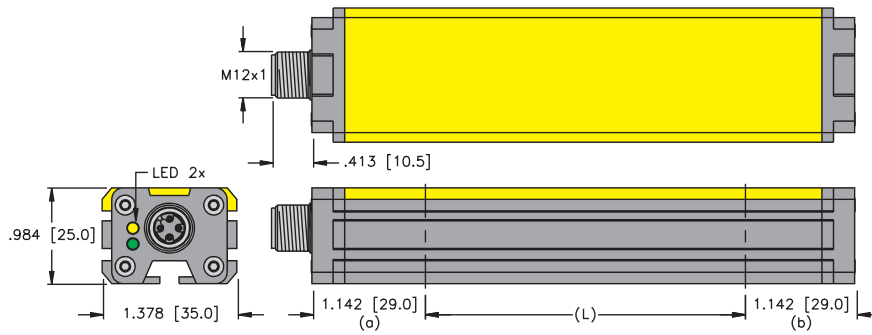

Note: Right angle cable direction

Measuring range specifications

Measuring ranges (L)	100, 200, 300, 400, 500, 600, 700, 800, 900, 1,000 mm
Blind zone (a)	29 mm
Blind zone (b)	29 mm

System

Resolution	12 bit (measuring range in mm / 4096)
Repeatability/accuracy	0.025 % (0.025 mm per 100 mm)
Linearity deviation	≤ 0.1 % of full scale
Temperature drift	≤ ± 0.002 %/K
Ambient temperature	-25 to + 70 °C
Output update rate	2 ms
Speed	25 m/s

Electrical data

Operating voltage	15-30 VDC
Residual ripple	≤ 10 % U_{pp}
No-load current	≤ 8 mA
Rated insulation voltage	≤ 0.5 kV
Short-circuit protection	yes
Wire breakage / reverse polarity protection	yes/yes
Output function	5-wire, analog output
Voltage output	0-10 V
Current output	4-20 mA
Load resistance of voltage output	≥ 4.7 kΩ
Load resistance of current output	≤ 0.4 kΩ

Housing style

Housing style	rectangular, Q25L
Dimensions	profile 35 x 25 mm, L = measuring range + 58mm
Housing material	aluminum
Material active face	plastic, PC-GF20
Connection	connector, M12 x 1
Vibration resistance	55 Hz (1 mm)
Shock resistance	30 g (11 ms)
Protection class (IEC 60529/EN 60529)	IP67

LEDs

Power indication	green LED
Measuring range indication	green/yellow multifunctional LED

Wiring diagram

5-pin M12 *eurofast*® connection

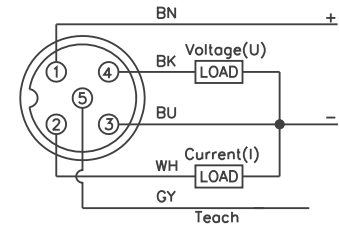

Mating cordset: RK 4.5T-*/S618

Q-track™ linear position sensors

E-series with enhanced resolution and SSI interface



Product features

- Enhanced resolution, up to 20 bit, depending on sensor length
- Enhanced sample rate, 1 KHz
- Excellent temperature stability and linearity through direct digital signal transmission
- SSI interface
- M12 *eurofast*® connector (8-pin)
- 29 mm blind zones
- Robust extruded aluminum housing
- Watertight (IP67) polycarbonate insert
- Multifunction LED

Measuring range indicated via LED

- **Green:** The positioning element is in the measuring range.
- **Green/yellow alternate flashing:** The positioning element is in the measuring range with a lower signal quality (i.e. distance too long).
- **Yellow flashing:** The positioning element is outside of the measuring range (max. range).
- **Off:** The positioning element is outside the programmed range but inside the total, non-programmed measuring length.

High-precision digital SSI output

SSI (synchronous serial interface) is a 4 wire data communication standard commonly used in industry to transmit position data digitally. The conductors in the cable are shielded twisted pairs that enhance EMI/RFI protection. In addition to the clock and data wires, it also has separate power wiring.

Part number key

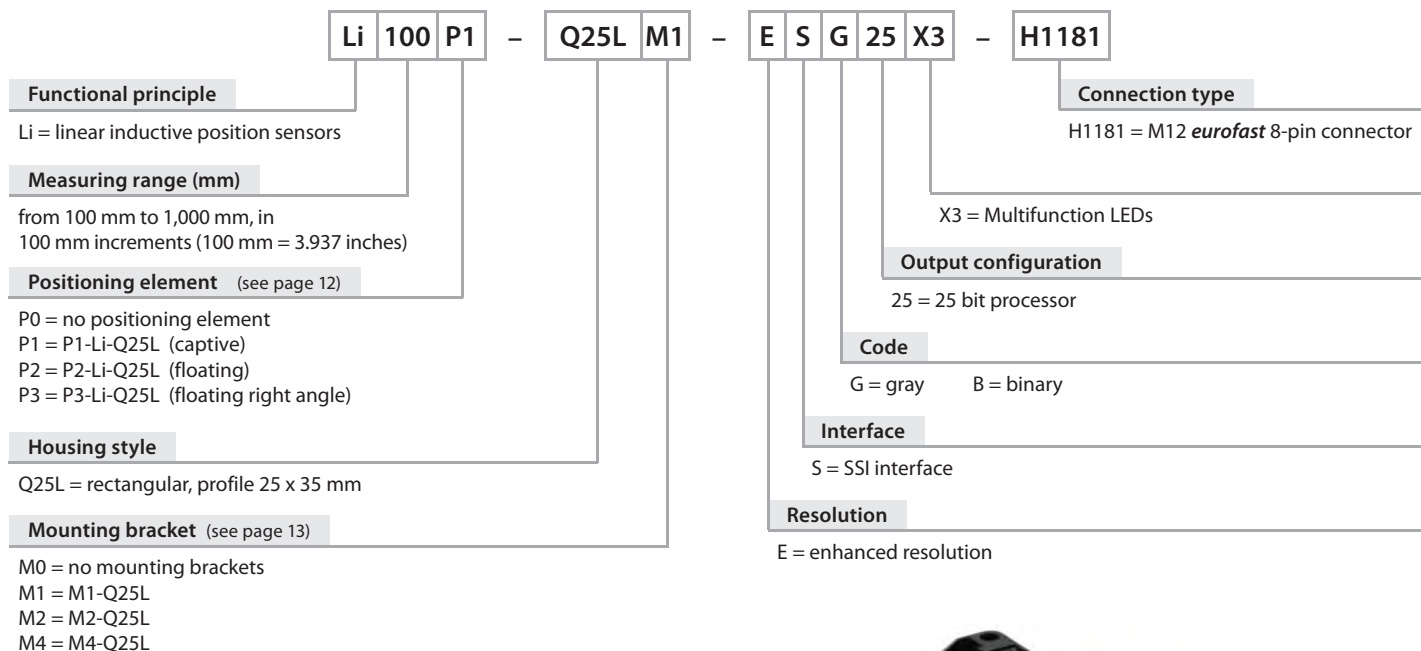

Ordering information

The *Q-track* linear position sensors are available in different lengths from 100 to 1,000 mm, in increments of 100 mm. The sensors, mounting accessories and positioning elements are available individually or as a kit.



Assembly part number:
Li100P2-Q25LM1-ESG25X3-H1181

E-series with enhanced resolution and SSI interface

Technical data



Dimensions

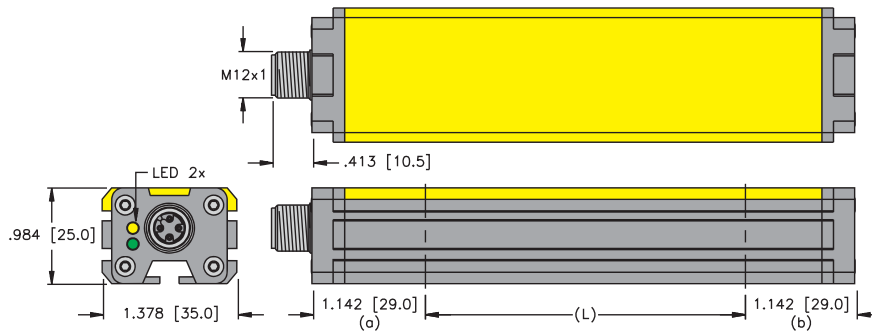

Note: Right angle cable direction

Measuring range specifications

Measuring ranges (L)	100, 200, 300, 400, 500, 600, 700, 800, 900, 1,000 mm
Blind zone (a)	29 mm
Blind zone (b)	29 mm

System

Resolution	0.001 mm
Repeatability/accuracy	10 μ m (0.01 mm)
Linearity deviation	≤ 0.1 % of full scale
Temperature drift	$\leq \pm 0.0001$ %/K
Ambient temperature	-25 to +70 °C
Output update rate	1 ms
Speed	50 m/s

Electrical data

Operating voltage	15-30 VDC
Residual ripple	≤ 10 % U_{pp}
Rated insulation voltage	≤ 0.5 kV
Short-circuit protection	yes
Wire breakage / reverse polarity protection	yes/yes (voltage supply)
Output function	8-wire, SSI, 25 bit Gray code
Current consumption	< 100 mA

Housing style

Housing style	rectangular, Q25L
Dimensions	profile 35 x 25mm, L = measuring range + 58mm
Housing material	aluminum
Material active face	plastic, PC-GF20
Connection	connector, M12 x 1
Vibration resistance	55 Hz (1 mm)
Shock resistance	30 g (11 ms)
Protection class (IEC 60529/EN 60529)	IP67

LEDs

Power indication	green LED
Measuring range indication	green/yellow multifunctional LED

Wiring diagram

8-pin M12 eurofast® connection

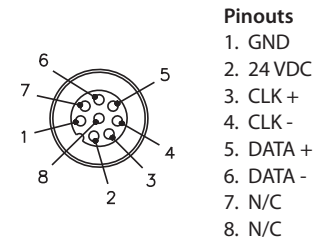

Mating cordset: E-RKC 8T-264-*

Q-track™ linear position sensors

E-series with enhanced resolution, IO-Link compatible



Product features

- Enhanced resolution of 16 bit
- Enhanced sample rate 1 kHz
- Improved linearity
- Two programmable outputs (analog output current or voltage, switching outputs, PWM) IO-Link compatible
- M12 *eurofast*® connector (5-pin)
- 29 mm blind zones
- Robust extruded aluminum housing
- Watertight (IP67) polycarbonate insert
- Multifunction LED

Measuring range indicated via LED

- **Green:** The positioning element is in the measuring range.
- **Green/yellow alternate flashing:** The positioning element is in the measuring range with a lower signal quality (i.e. distance too long).
- **Yellow flashing:** The positioning element is outside of the measuring range (max. range).
- **Off:** The positioning element is outside the programmed range but inside the total, non-programmed measuring length.

Programming and IO-Link

Output functions, measuring ranges and alarm outputs are set via a teach adapter or programming line (pin 5). Alternatively, the sensor can also be operated in IO-Link mode. For this purpose, connect the sensor to an IO-Link compatible module. The established connection is indicated by a green flashing LED. For more information, please see the corresponding instruction manual.

Available for order January 2011.

Part number key

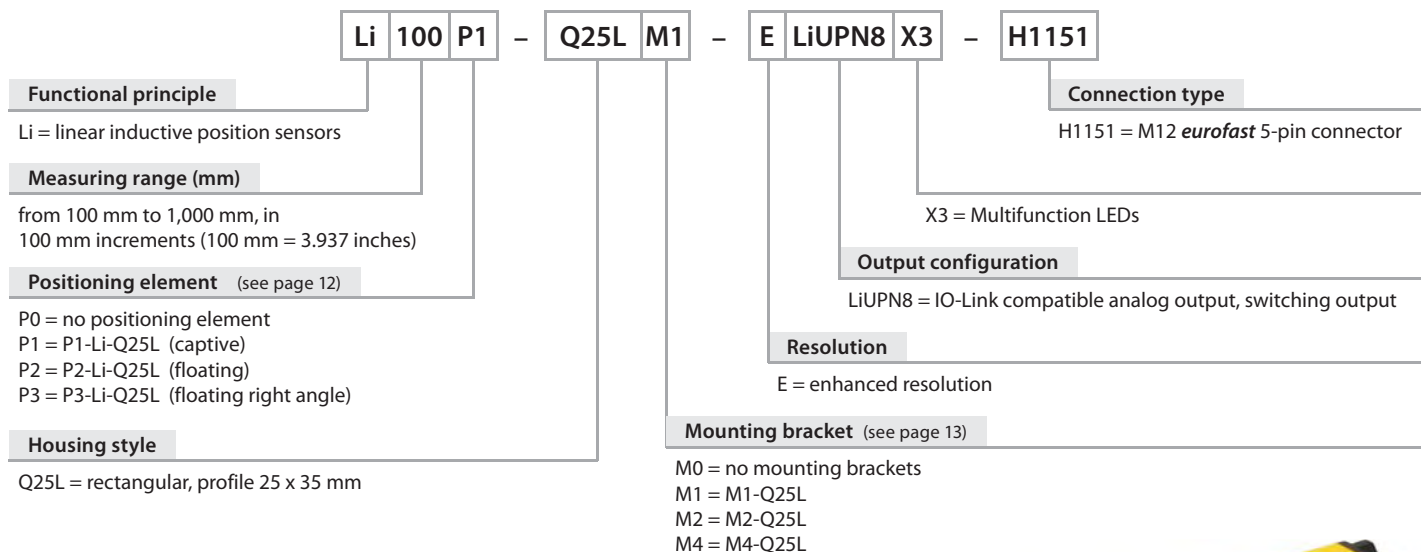

Ordering information

The *Q-track* linear position sensors are available in different lengths from 100 to 1,000 mm, in increments of 100 mm. The sensors, mounting accessories and positioning elements are available individually or as a kit.



Assembly part number:
Li300P1-Q25LM1-ELIUPN8X3-H1151

E-series with enhanced resolution, IO-Link compatible

Technical data



Dimensions

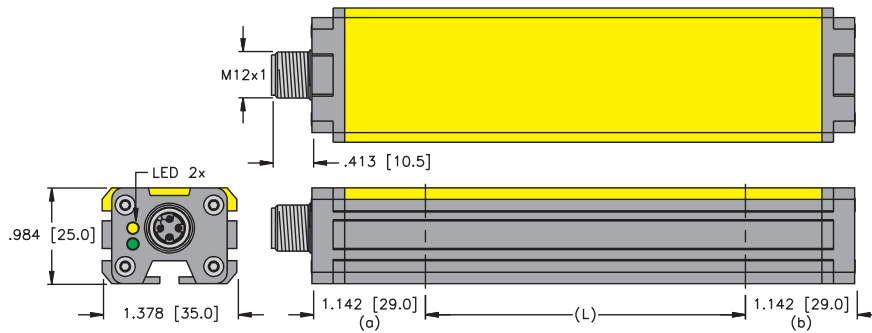

Note: Right angle cable direction

Measuring range specifications

Measuring ranges (L)	100, 200, 300, 400, 500, 600, 700, 800, 900, 1,000 mm
Blind zone (a)	29 mm
Blind zone (b)	29 mm

System

Resolution	16 bit (D/A converter and IO-Link) (measuring range in mm / 65536)
Repeatability/accuracy	0.0015 % (0.0015 mm per 100 mm)
Linearity deviation	≤ 0.1 % of full scale
Temperature drift	≤ ± 0.001 % / K
Ambient temperature	-25 to + 70 °C
Output update rate	1 ms
Speed	50 m/s

Electrical data

Operating voltage	15-30 VDC
Residual ripple	≤ 10 % U_{pp}
Rated insulation voltage	≤ 0.5 kV
Short-circuit protection	yes
Wire breakage / reverse polarity protection	yes/yes (voltage supply)
Output function	two programmable outputs (analog output current or voltage, switching outputs, PWM, ...) IO-Link compatible
Current consumption	< 100 mA

Housing style

Housing style	rectangular, Q25L
Dimensions	profile 35 x 25 mm, L = measuring range + 58 mm
Housing material	aluminum
Material active face	plastic, PC-GF20
Connection	connector, M12 x 1
Vibration resistance	55 Hz (1 mm)
Shock resistance	30 g (11 ms)
Protection class (IEC 60529/EN 60529)	IP67

LEDs

Power indication	green LED
Measuring range indication	green/yellow multifunctional LED

Wiring diagram

5-pin M12 eurofast® connection

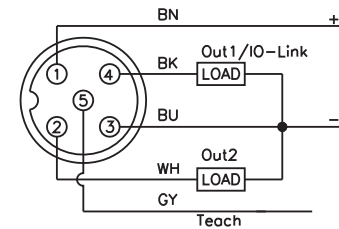

Mating cordset: RK 4.5T-*/S618

Sample configuration - I/O Link Master, piconet®

The following components are required to connect a linear position sensor through IO-Link to PROFIBUS®:

1 x I/O-Link Master, **piconet®**: SDPX-10L4-0001

1 x connection cable: **RK 4.5-2-RS 4.5T**



Accessories – Fieldbus connection

The *Q-track*™ linear position sensor with SSI interface is compatible with all fieldbus devices



Part number	Description
-------------	-------------

BL20® – Distributed I/O, IP20 rated device

Select one	BL20-GW-EN-IP	Gateway Ethernet/IP™
	BL20-GW-DPV1	Gateway PROFIBUS®-DP
	BL20-GWBR-DNET	Gateway DeviceNet™
	BL20-GWBR-CANOPEN	Gateway CANopen
	BL20-GW-EN	Gateway Ethernet Modbus TCP
	BL20-PG-EN	Gateway Ethernet Modbus TCP, programmable
	BL20-GW-PG-EN	Gateway Ethernet PROFINET® IO
	BL20-1SSI	Communication module
	BL20-S4T-SBBS	Connection module, tension-spring connection
	E-RKC 8T-264-2	Connection cable M12, 8-pin, 2 m cable (end open) to connect <i>Q-track</i> ™ linear position sensors with SSI output to BL20 fieldbus stations.



BL67® – Distributed I/O, IP67 rated device

Select one	BL67-GW-EN-IP	Gateway Ethernet IP
	BL67-GW-DPV1	Gateway PROFIBUS®-DP
	BL67-PG-DP	Gateway PROFIBUS-DP, programmable
	BL67-GW-DN	Gateway DeviceNet
	BL67-GW-CO	Gateway CANopen
	BL67-GW-EN	Gateway Ethernet Modbus TCP
	BL67-PG-EN	Gateway Ethernet Modbus TCP, programmable
	BL67-GW-EN-PN	Gateway Ethernet PROFINET IO
	BL67-1SSI	Communication module
	BL67-B-1M12-8	Connection module M12 <i>eurofast</i> ®, 8-pin
BL67-B-1M23	Connection module M23 <i>multifast</i> ®, 12-pin	
E-RKC 8T-264-2-RSC 8T	Connection cable M12 <i>eurofast</i> , 8-pin, 2 m to connect <i>Q-track</i> linear position sensors with SSI output to BL67 and BL compact fieldbus stations.	
E-RKS 8T-264-1-CSWM12/S3085	Connection cable M12 <i>eurofast</i> , 8-pin, on M23 <i>multifast</i> 12-pin, 1m to connect <i>Q-track</i> linear position sensors with SSI output to BL67 and <i>piconet</i> fieldbus stations.	



BL compact – Robust, IP67 rated device

BLCEP-1M12MT-1SSI	Ethernet IP, M12 <i>eurofast</i> , 8-pin
E-RKC 8T-264-2-RSC 8T	Connection cable M12 <i>eurofast</i> , 8-pin, 2 m to connect <i>Q-track</i> linear position sensors with SSI output to BL67 and BL compact fieldbus stations.

Sample configuration - BL67

The following components are required to connect a *Q-track* linear position sensor to a Ethernet IP system via a **BL67** station:

- 1 x Ethernet IP gateway: **BL67-PG-EN-IP**
- 1 x communication module: **BL67-1SSI**
- 1 x connection module: **BL67-B-1M12-8**
- 1 x connection cable: **E-RKC 8T-264-2-RSC 8T**





Part number	Description
-------------	-------------

Connection cable for standard series and E-series with analog output	
--	--

RK 4.5T-2/S618	M12 <i>eurofast</i> ®, 5-pin female, shielded, 2 meter cable with flying leads. Other lengths available upon request.
RK 4.5T-2-RS 4.5T (as shown)	M12 <i>eurofast</i> , 5-pin 2 meter extension cable with male and female connectors. To connect <i>Q-track</i> ™ linear position sensors with analog output to TB4. Other lengths available upon request.
RKC 4.5T-2-RSS 4.5T	M12 <i>eurofast</i> , 5-pin 2 meter extension cable with male and female connectors. To connect <i>Q-track</i> ™ linear position sensors with analog output to TB4. Other lengths available upon request. Shield connected to male coupling nut for use in high noise environments.



Connection cable for E-series with SSI interface	
--	--

E-RKC 8T-264-2	M12 <i>eurofast</i> , 8-pin female connector with 2 meter cable with flying leads. To connect <i>Q-track</i> linear position sensors with SSI output to <i>BL20</i> ® fieldbus stations.
E-RKC 8T-264-2-RSC 8T	M12 <i>eurofast</i> , 8-pin female connector with 2 meter cable to M12 <i>eurofast</i> , 8-pin male connector. To connect <i>Q-track</i> linear position sensors with SSI output to <i>BL67</i> ® and <i>BL compact</i> fieldbus stations.
E-RKS 8T-264-0.5-CSWM12/S3085 (as shown)	M12 <i>eurofast</i> , 8-pin female connector with 0.5 meter cable to right angle M23 <i>multifast</i> ®, 12-pin male connector. To connect <i>Q-track</i> linear position sensors with SSI output to <i>BL67</i> and fieldbus stations.



Teach adapter	
---------------	--









VB2-SP5	Teach adapter to program the measuring range of <i>Q-track</i> linear position sensors.
---------	---

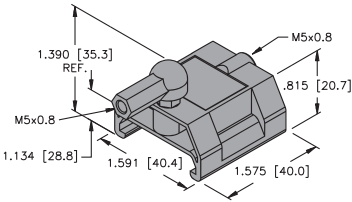

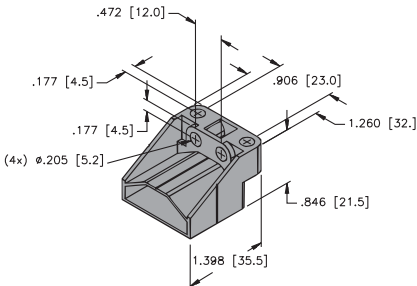
Test box	
----------	--

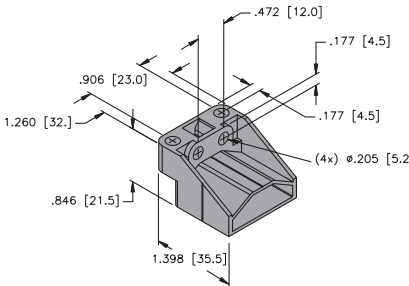
TB4	Test box for sensors with analog or switching output; batteries included. May also be used to program zero and span.
-----	--

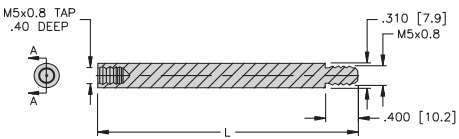
Position elements

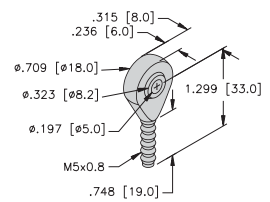
Dimensions	Part number	Description
		<p>P1-Li-Q25L</p> <p>Captive positioning element; laterally inserted in sensor groove; incl. rod-end bearing to mount M5 threaded rods</p>
		<p>P2-Li-Q25L</p> <p>Floating positioning element, operates at a distance of 0-4 mm to the sensor surface</p>
		<p>P3-Li-Q25L</p> <p>Floating positioning element; right angle orientation; operates at a distance of 0-4 mm to the sensor surface</p>
		<p>CA*E-Q21</p> <p>Control arm; Can be used with P1-Li-Q25L and RE-Q21 to connect the positioning element to an actuator.</p>
		<p>RE-Q21</p> <p>Rod End; Can be used with P1-Li-Q25L and CA*E-Q21 to connect the positioning element to an actuator.</p>

Mounting accessories

A comprehensive range of accessories is available for mounting. Sliding blocks, the sensor groove and different brackets provide many mounting possibilities. Flexibility is guaranteed, as accessories are available for all borehole distances



Dimensions	Part number	Description
	M1-Q25L	Mounting foot for <i>Q-track</i> ™ linear position sensors; Two mounting feet should be used for devices with a measuring range of up to 1,000 mm; Material: stainless steel; 2 pcs. per bag.
	M2-Q25L	Mounting foot for <i>Q-track</i> linear position sensors; Two mounting feet should be used for devices with a measuring range of up to 1,000 mm; Material: stainless steel; 2 pcs. per bag.
	M4-Q25L	Mounting bracket for <i>Q-track</i> linear position sensors; Two mounting feet should be used for devices with a measuring range of up to 1,000 mm; Material: stainless steel; 2 pcs. per bag.
	MN-M4-Q25	Sliding blocks with M4 thread for back side groove of <i>Q-track</i> linear position sensors; Material: Brass; 10 pcs. per bag. Only available separately, not as a kit with linear position sensors.



USA

TURCK Inc.
3000 Campus Drive
Minneapolis, MN 55441
Phone: (763) 553-7300
Fax: (763) 553-0708
Application Support:
1-800-544-7769
E-mail: turckusa@turck.com
www.turck.us



MEXICO

TURCK MEXICO S. DE R.L. DE C.V.
Carr. Saltillo-Zacatecas km 4.5 s/n
Parque Industrial "La Angostura"
Saltillo, COAH. C.P. 25070
Mexico
Phone: +52 (844) 411-6650/46
Fax: +52 (844) 482-6926
Local Toll Free: 01-800-01-88725
E-mail: ventasmexico@turck.com



CANADA

Chartwell Automation Inc.
140 Duffield Drive
Markham, Ontario
Canada, L6G 1B5
Phone: (905) 513-7100
Fax: (905) 513-7101
Toll Free: 1-877-513-7769



AUSTRALIA

TURCK Australia Pty. Ltd.
Unit 5, 6-7 Gilda Court
Mulgrave, Victoria 3170
Australia
Phone: (+61) 3 9560 9066
Fax: (+61) 3 9560 1620
Local Toll Free: 1300 132566
E-mail: turckaustralia@turck.com



GERMANY

WORLD HEADQUARTERS

Hans TURCK GmbH & Co. KG
Witzlebenstrasse 7
D-45472 Muelheim an der Ruhr
Federal Republic of Germany
Phone: (+49) 208-49 52-0
Fax: (+49) 208-49 52 264

www.turck.com

....**Sense It!**....**Connect It!**....**Bus It!**....**Solve It!**