

# Quik-Spec™ Electrical Gear

## Section Contents

	Page
<b>Quik-Spec Coordination Panel Boards . . . . .</b>	<b>238-239</b>
<b>Quik-Spec Power Module Switches and Panels . . . . .</b>	<b>240-241</b>
<b>Quik-Spec DC Safety Switches . . . . .</b>	<b>242</b>
<b>Quik-Spec Solar Combiner Boxes . . . . .</b>	<b>243-244</b>
<b>Quik-Spec AC Safety Switches . . . . .</b>	<b>245-246</b>
<b>A/C Disconnects - Fused and Non-Fused . . . . .</b>	<b>247</b>

RED indicates NEW information



Quik-Spec™  
Electrical  
Gear

# Quik-Spec™ Coordination Panelboard

## The Quik-Spec Coordination Panelboard Makes Selective Coordination Easy...up to 400A Mains and 100A Branches!\*

### Easy-to-Spec

- The Quik-Spec Quik-Quote™ online configurator makes specifying, pricing and ordering simple, fast and virtually error free. Just log in, select the ratings, features and options you want, and instantly get back pricing for any Coordination Panelboard possible. Contact your Cooper Bussmann representative for access.

### Saves Time

- Enclosure ships within one week of order so installation can start fast. Interior with fuses ships later for jobsite installation. Spare fuses included with chassis shipment so replacements are always on hand.
- Specify Quik-Ship when you order and your product will ship within 10 business days. Available on all NEMA 1 enclosure configurations - just make sure your Cooper Bussmann representative knows you want Quik-Ship.

### Flexible Configurations – Up to 600Vac/400 Amp/200kA SCCR, or 125Vdc/400 Amp/100kA SCCR\*\*

- 30, 60, 100, 200, 225 and 400A main ratings
- 125Vdc rating ideal for utility and petro-chem control circuits or UPS circuits
- 1 to 100 amp fuse ratings to closely match loads
- Available in fused or non-fused main disconnect switch, or MLO (Main Lug Only) configurations with a choice of 18, 30 and 42 branch positions, up to 100A, in NEMA 1 or 3R enclosures to easily meet branch or service panel installations needs
- Feed through lugs or fused loadside disconnect available

### Same Size Footprint as Traditional, Circuit Breaker Panelboards

- 20" W x 5" D x various heights (depending on configuration)

### Addresses NEC® Selective Coordination Requirements

- This cULus Listed panelboard makes it easy to provide systems that comply with NEC® Selective Coordination Requirements\*\*\* for Emergency, Legally Required Standby, Healthcare Essential Electrical and Critical Operation Power Systems (COPS) per 700.27, 701.18, 517.26 and 708.54.
- Full fuse-system selective coordination is easy from source to branch. Just follow published fuse selective coordination ratios – no need for plotting time-current curves or expensive studies.



### Increases Safety

- Utilizes the finger-safe Low-Peak® CUBEFuse® in a size-rejecting Compact Circuit Protector (CCPB) base. Fuse interlock prevents removing fuse while energized. Fuse ampacity rejection feature coincides with standard fuse size and copper conductor ampacities to help prevent overfusing.
- UL 98 branch circuit disconnect-rated CUBEFuse® Compact Circuit Protector Base with fuse ampacity-rejection feature breaks at 15A, 20A, 30A, 40A, 50A, 60A, 70A, 90A and 100A
- Local open fuse indication on branch circuit device and optional indicating CUBEFuse
- Lockout/Tagout provision eases OSHA compliance
- Lock-On provision helps meet requirements for emergency circuits
- High fuse interrupting rating and up to 200kA assembly SCCR ratings easily exceed most available fault current levels to help assure compliance with NEC® 110.9 and 110.10. Current-limitation of a fused solution also reduces arc-flash hazards and minimizes damage to equipment and circuits.

### Quik-Ship - 10 Business Day Shipment

- All configurations of the standard enclosure Quik-Spec Coordination Panelboard are available for shipment within 10 business days of order. Consult factory for details.

\*70A, 90A and 100A branch disconnects coming soon.

\*\*125Vdc rating applicable to 40 amp or less CCPBs on MLO panels only.

\*\*\*When used in a fully fused distribution system.

# Quik-Spec™ Coordination Panelboard

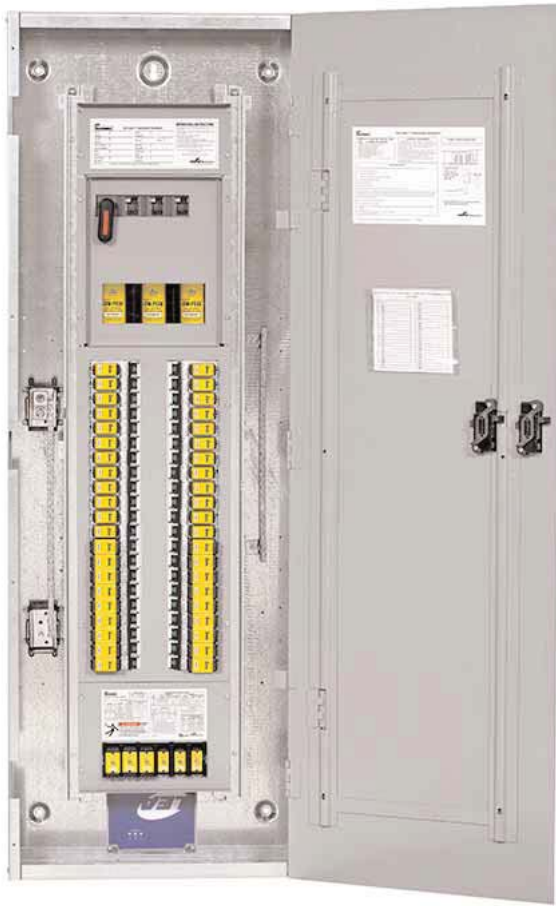

## Coordination Panelboard Specifications

- Mains:**
  - MLO (Main Lug Only)
  - Fused Disconnect Switch
  - Non-fused Disconnect Switch

---

- Assembly SCCR:** • 200kA, 100kA or 50kA AC, 100kA or 20kA@125Vdc\*

---

- Voltage Rating:** • Applicable on any 600Vac or less, or 125Vdc\*\* or less systems

---

- Bus Ampacity:** • 400A, 225A, 200A, 100A, 60A or 30A
- Branch Circuits:** • Circuits; Up to 18, 30 and 42\*
  - Amps; Up to 100A
  - Type; 1-, 2- and 3-Pole

---

- Panel:**
  - Feed; Top & Bottom\*\*\*
  - Mounting; Surface or Flush\*\*\*\*
  - Door/Trim; Regular or Door-in-Door\*\*\*\*
  - NEMA Ratings; 1 & 3R. Other ratings available. Consult factory.

---

- Through-Lugs & Loadside Disconnect:**
  - Feed-Through - single and double
  - Fused loadside disconnect, ≥100A- <200A (400A panels only)
- Neutrals:**
  - 200A, 400A and 800A Unbonded and Bonded

---

- Ground:**
  - Non-Isolated or Isolated
- Enclosure Size:** • Standard size panelboard (20" W x 5" D x various heights)\*

---

- Spare Fuses:** • Six-fuse spare fuse compartment
- Options:** • Surge Protection Device (TVSS) for high and low energy transients.

\* Depending on configuration  
 \*\* 125Vdc rating applicable to 40 amp or less CCPBs on MLO panels only.  
 \*\*\* Top feed not available on NEMA 3R enclosure  
 \*\*\*\* Flush mount and Door-in-Door not available with NEMA 3R enclosure

Quik-Spec™  
 Electrical  
 Gear

## Quik-Spec™ Power Module — All-in-one Elevator Disconnect

### PS & PMP

Cooper Bussmann® Quik-Spec Power Module

#### Specifications

Description: Fusible power switch or panel with shunt trip and fire safety interface to allow for single point tie in with fire alarm system.

#### Ratings:

- Volts: — 600Vac, 3Ø
- Amps: — 30-400A (PS)
  - 30-200A (PMP feeder switches)
  - 400-800A (PMP main switches\*)

#### Assembly

SCCR: — 200,000A rms

\*Contact Cooper Bussmann for applications greater than 800A.

Agency Information: Complies with NFPA 70 (NEC®; National Electrical Code®),

- Elevator Shutdown — ANSI/ASME A17.1, 2.8.3.3.2
  - NEC® 620.51(B) (Elevator Shutdown)
  - NEC® 240.12 (Orderly Shutdown)
- Shunt Trip Voltage Monitoring — NFPA 72, 6.16.4.4
- Selective Coordination — NEC® 620.62
- Auxiliary Contact (Hydraulic Elevator) — NEC® 620.91(C)
  - Power Module Switch (PS); UL Listed (UL 98) Enclosed and Dead front switch Guide 96NK3917, File E182262, NEMA 1, UL 50 Listed enclosure\*\*, cUL per Canadian Standards C22.2, No. 0-M91-CAN/CSA C22.2, No. 4-M89 Enclosed switch.

\*\*NEMA 12, 3R, and 4 enclosures also available

- Power Module Panel (PMP); UL 98 Enclosed and Deadfront Switches.

#### Features and Benefits:

- Internally powered, relay activated shunt trip system
- Mechanically interlocked auxiliary contact
- Self-contained adherence to elevator consensus standards, NFPA 70 (NEC®). NFPA 72, ANSI/ASME 17.1
- Shunt trip capability
- Selective coordination
- Fire safety signal interface
- Shunt trip voltage monitoring
- Component protection via Cooper Bussmann® Low-Peak® Class J fuses
- UL 98 Listed for 200kA short-circuit current rating
- Lockable in the open position with three-lock capability
- Optional key-test switch and optional pilot light for easy inspection
- No annual calibration or testing of overcurrent protection required
- Padlockable for service-work safety and open-door “override” for troubleshooting

#### Typical Applications:

- Elevator Disconnects
- Computer Room Shunt Trip Disconnect
- Fire Safety Interface Relay

#### Accessories:

- For added safety, use the Cooper Bussmann® SAMI™ fuse covers to improve maintenance personnel protection (OSHA 1910.333, paragraph C)

#### Ordering:

The Cooper Bussmann Quik-Spec™ Power Module Switch and Panel are factory configured to the specific application. Contact your Cooper Bussmann representative to place your order. Have all relevant electrical and circuit information on hand.

#### PS\*

The Quik-Spec™ Power Module Switch (PS) for single elevator applications.



#### PMP\*

Power Module™ Panel (PMP) for multiple elevator applications.



\*Fused main disconnect requires Class J fuses, not supplied with switch.

# Quik-Spec™ Power Module — All-in-one Elevator Disconnect

## Hydraulic Elevators

Hydraulic elevators need battery backup to help prevent stranding passengers. To keep the elevator from moving when it's been manually shut down for maintenance, the NEC® requires battery backup be connected to the elevator disconnecting means through an auxiliary contact.

However, an unintended consequence can be passengers getting stranded because of devices that open automatically (circuit breakers and disconnects utilizing a

molded case switch with a trailing fuse block) will operate with a fault on their loadside. That operation also disables the battery backup and strands passengers. That's why the Power Module has a non-automatic fusible shunt trip switch. If the Power Module has a fault on its loadside, the fuses open and the battery stays enabled. Thus the Power Module ensures that battery power is enabled when the passengers need it to exit - and disabled to allow safe maintenance of the elevator and hoistway.

Scenario	Battery Lowering Required	Reason	Offered By Power Module™	Offered By Other Elevator Disconnects
Power failure	Yes	Need to lower elevator to allow passengers to exit.	Yes	Yes
Fire in shaft or machine room	No	Recall is initiated by smoke detector and lowers elevator to a safe floor. Battery not needed.	Yes	Yes
Disconnect manually opened	No	Worker to perform maintenance. Elevator must remain stationary to prevent injury.	Yes	Yes
Fault on loadside of disconnect	Yes	Need to lower elevator to allow passengers to exit.	Yes	No

## Quik-Spec™ Power Module Switch Catalog Numbering System

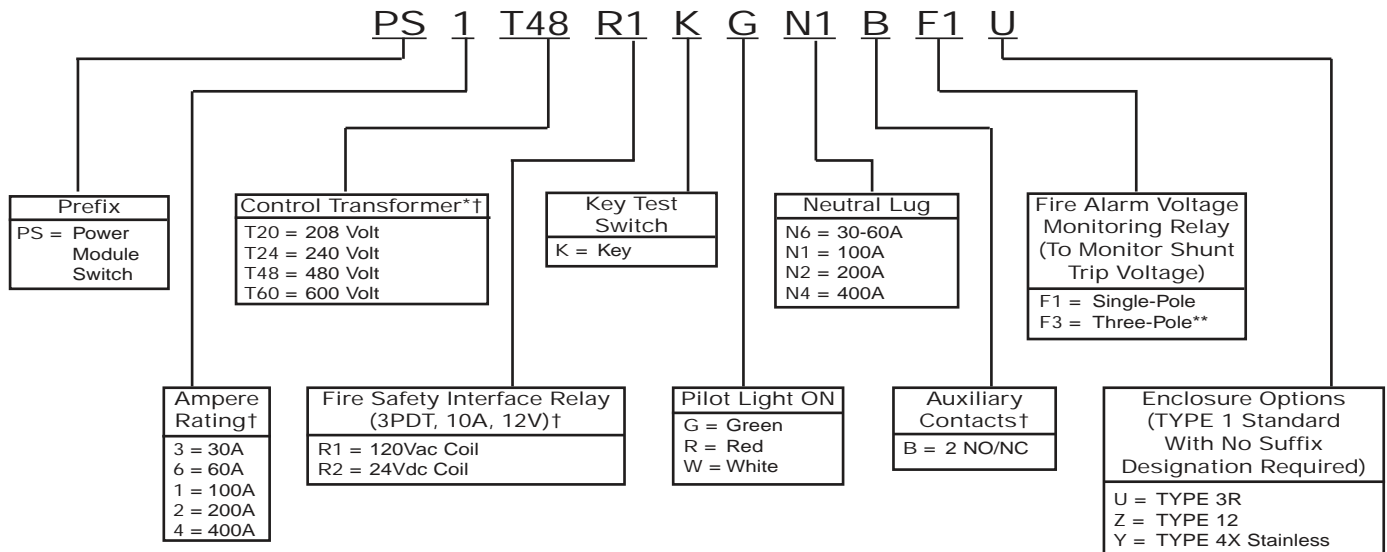

\*100Va with Primary and Secondary fusing (120V Secondary)

\*\*Only for use with R1 option

†Required Equipment

### Quik-Ship Program: Switch - 3 Days, Panel - 10 Days!

Ship-direct service within three business days for Power Module Switches (PS\_) and 10 business days for Power Module Panels (PMP\_).

\* Three day PS\_ shipment requires ordering from catalog numbers shown.

\*\* 10 Day PMP\_ shipment covers NEMA 1 enclosures with the ampacities shown and all requirements for relay type (AC or DC), accessory options and number of switches. To order PMP\_, contact your Cooper Bussmann representative with all relevant electrical and circuit information, we do the rest.

Power Module Switch*			Power Module Panel**	
Cat Numbers	Amps	Volts	Cat. Numbers	Amps
PS6T48R1KGBF3-X	60A	480V	PMP-400-X	400A
PS1T48R1KGBF3-X	100A	480V	PMP-600-X	600A
PS1T20R1KGBF3-X	100A	208V	PMP-800-X	800A
PS2T48R1KGBF3-X	200A	480V		
PS2T20R1KGBF3-X	200A	208V		

# Quik-Spec™ DC Safety Switch

Isolating DC Circuits Has Never Been Easier *or* Safer

- Flexibility of Application
- Enhanced Finger-Safe Design
- Meets UL and NEC® Requirements
- Flange Handle Operation
- Current-Limiting Fuses Reduce Arc Flash Hazard

**NEC 690.17 Compliant Label**

Warns that the switch terminals may be energized in the open position

**High Visibility Padlockable Handle**

Easy to operate with gloves and up to three padlocks to protect maintenance personnel

**Visible Switch Contacts**

Positive visual identification of switch state

**Door Interlock**

Prevents opening door while energized, but can be manually overridden for testing or inspection.

**Clear Polycarbonate Deadfront**

Covers energized parts to provide added protection against electrical hazards. Lineside stays in place during fuse servicing.

**Fused Version For Added Protection**

Fuse clips located on switch center pole to ensure both clips are de-energized in OFF position. Meets NEC® Article 690.16 that requires isolating the fuse from all potential supply sources. Cooper Bussmann recommends using the Limitron® fast-acting, current limiting PVS-R Class RK5 fuse (order separately.)

**NEMA 3R, 12 & 4X Enclosures**

Meet many application requirements. 3R and 4X stainless steel well suited for isolating outdoor solar power installations

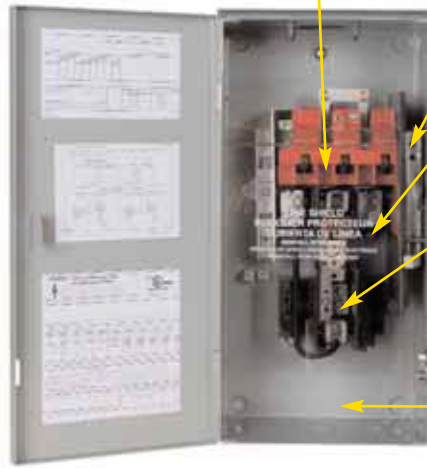

**Conduit Knockouts**

For easy conductor installation

**Type 3R Dimensions**

Amps	A	B	C	Main Lug Capacity	Neutral Lug Capacity	I <sub>sc</sub>
30	16.35	8.87	9.89	#2 AWG - #14 AWG Al/Cu	#4 AWG - #14 AWG Al/Cu	19.2
60	16.35	8.87	9.89	#2 AWG - #14 AWG Al/Cu	#4 AWG - #14 AWG Al/Cu	38.4
100	22.15	11.84	9.89	1/0 AWG- #14 AWG Al/Cu	#4 AWG - #14 AWG Al/Cu	64.0
200	28.27	16.66	11.26	250kcmil - #6 AWG Al/Cu	#2 AWG - #14 AWG Al/Cu	128.0

**Type 12 & 4X Dimensions**

Amps	A	B	C	Main Lug Capacity	Neutral Lug Capacity	I <sub>sc</sub>
30 & 60 Non-fusible	14.14	8.76	10.22	#2 AWG - #14 AWG Al/Cu	#4 AWG - #14 AWG Al/Cu	19.2
30 & 60 Fusible	19.08	8.76	10.22	#2 AWG - #14 AWG Al/Cu	#4 AWG - #14 AWG Al/Cu	19.2
100	24.95	11.79	10.22	1/0 AWG- #14 AWG Al/Cu	#4 AWG - #14 AWG Al/Cu	64.0
200	35.38	16.95	11.63	250kcmil - #6 AWG Al/Cu	#2 AWG - #14 AWG Al/Cu	128.0

**Dimensions - in**

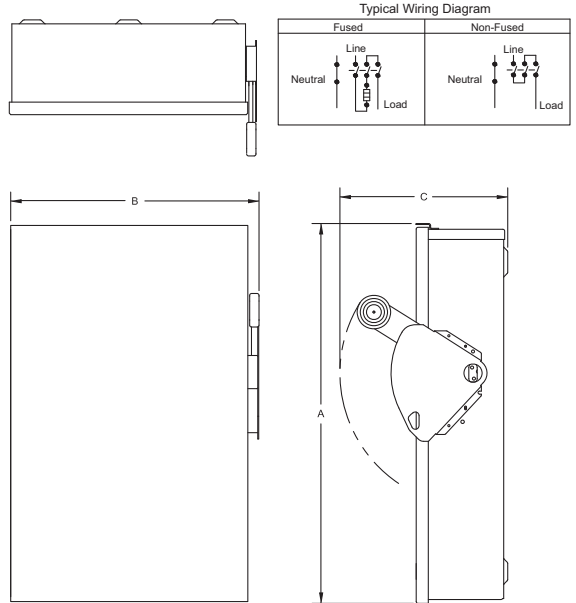

**DC Safety Switch Catalog Numbering System**

Use this build-a-code to specify the exact Quik-Spec DC Safety Switch you need.

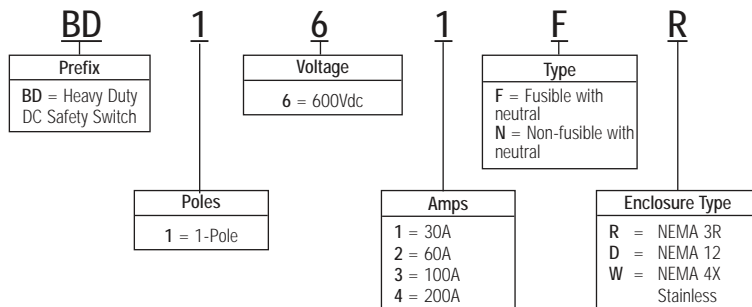

## Quik-Spec™ Solar Combiner Boxes



BCBS Series Standard Box



BCBC Series Compact Box



BCBD Series Integrated Disconnect Box

### BCBS Series Standard Combiner Boxes and BCBD Series with Integrated Disconnect

- 4 to 24 Input circuits
- ETL Listed to UL1741 Standard
- DCM\*\* or KLM\*\*\* 600Vdc midget fuses for overcurrent protection
- Finger-safe Cooper Bussmann modular fuse holders\*\*\*\*
- Finger-safe power distribution blocks\*\*\*\*\*
- Continuous duty rated at 600Vdc
- Configured for both positive and negative grounded arrays
- Single or dual 90°C output terminals
- Steel or fiberglass NEMA 3, 3R, 4 or 4X rated enclosures with seamless door gaskets
- Negative Input Terminal Blocks
- All products are assembled in the USA

#### With Integrated Disconnect Only

- 28, 55, 75, 150 and 245A Integrated disconnects

### BCBC Series Compact Combiner Boxes

- 2 to 6 Input circuits
- Continuous duty rated at 600Vdc
- DCM\*\* or KLM\*\*\* 600Vdc midget fuses for overcurrent protection
- Finger-safe Cooper Bussmann modular fuse holders\*\*\*\*
- ETL Listed to UL1741 Standard
- NEMA 4X Polycarbonate enclosure
- Ground blocks included
- External mounting feet included

#### BCBC Series Compact Combiner Box Specifications\*

Number of Input Circuits	2 to 4	5 to 6
Input Conductor Range	6-14AWG	6-14AWG
Number of Output Conductors	1	1
Output Conductor Range	6-14AWG	6-14AWG
Max Fuse Size	30A	30A
Max Rated Current (DC Continuous)	76A	76A
NEMA Enclosure Ratings	4X	4X
Enclosure Dimensions (in), Weight	6.5x6.5x4, 4 lbs	6.5x9.5x4, 4 lbs

#### BCBS Series Standard Combiner Box\*

Number of Input Circuits	4 to 12	16	20 to 24
Input Conductor Range	4-16AWG	4-16AWG	4-16AWG
Number of Output Conductors	1	1 or 2	1 or 2
Output Conductor Range	350kcmil-6AWG	350kcmil-6AWG	350kcmil-6AWG
Max Fuse Rating	30A	30A	30A
Max Rated Current (DC Continuous)	310A	400A	400A
Max Voltage	600Vdc	600Vdc	600Vdc
NEMA Enclosure Ratings	3, 3R, 4, 4X	3, 3R, 4, 4X	3, 3R, 4, 4X
Steel Enclosure Dimensions (in), Weight	16x12x6, 30 lbs	16x16x6, 36 lbs	20x20x6, 46 lbs
Fiberglass Enclosure Dimensions (in), Weight	16x14x7, 18 lbs	22x18x9, 22 lbs	N/A/NA

\* Refer to next page for part number configuration.

\*\* See Data Sheet 2038 for details.

\*\*\* See Data Sheet 2020 for details.

\*\*\*\* See Data Sheet 2053 for details.

\*\*\*\*\* See Data Sheet 1049 for details.

Quik-Spec™  
Electrical  
Gear

#### BCBD Series Combiner Box with Integrated Disconnect\*

Disconnect Rating (Amps)	28A	55A	75A	150A	245A
Number of Input Circuits	4	4	4 to 12	4 to 24	4 to 24
Input Conductor Range	4-14AWG	4-14AWG	4-14AWG	4-14AWG	4-14AWG
Number of Output Conductors	1	1	1	1	1
Output Conductor Range	2/0-14AWG	2/0-14AWG	350kcmil-6AWG	350kcmil-6AWG	350kcmil to 6AWG
Max Fuse Size	30A	30A	30A	30A	30A
Max Rated Current (DC Continuous)	28A	55A	75A	150A	245A
Max Voltage	600Vdc	600Vdc	600Vdc	600Vdc	600Vdc
NEMA Enclosure Ratings	4, 4X	4, 4X	3, 3R, 4, 4X	3, 3R, 4, 4X	3, 3R, 4, 4X
Steel Enclosure Dimensions (in), Weight	12x10x6, 15 lbs	12x10x6, 15 lbs	20x20x6, 42 lbs	20x20x6, 50 lbs, or 20x24x6, 50 lbs	24x24x6, 55 lbs
Fiberglass Enclosure Dimensions (in), Weight	14x12x7, 12 lbs	14x12x7, 12 lbs	22x18x8, 28 lbs	24x20x10, 35 lbs, or 24x24x10, 35 lbs	24x24x10, 40 lbs

# Quik-Spec™ Solar Combiner Boxes

## Cooper Bussmann Solar Combiner Box Catalog Numbering System

Example: BCBD28-24-30R = B C B D 2 8 - 2 4 - 3 0 R

Series Prefix	BCBS – Combiner Box						
	BCBD – Combiner Box with Integrated Disconnect						
	BCBC – Compact Combiner Box						
Disconnect Ampacity	For ordering BCBD Series only - otherwise, leave blank						
	28	55	75	150	245		
Number of Poles Available (by Series)							
BCBS & BCBD Series:	04	08	12	16	20	24	
BCBC Series:		02	03	04	05	06	
Fuse Size (amps)*							
	00 – No Fuses Included						
	01	03	05	08	10	15	25
	02	04	06	09	12	20	30
* When fuses are specified, DCM or KLM 600Vdc fuses are included							
Enclosure							
	R – NEMA 3/3R	4 – NEMA 4 (Powder Coated Steel)					
	F – NEMA 4X (Fiberglass)	P – NEMA 4X (Polycarbonate)**					
**BCBC Only available with NEMA 4X (P) option							

## Typical Combiner Box Layouts

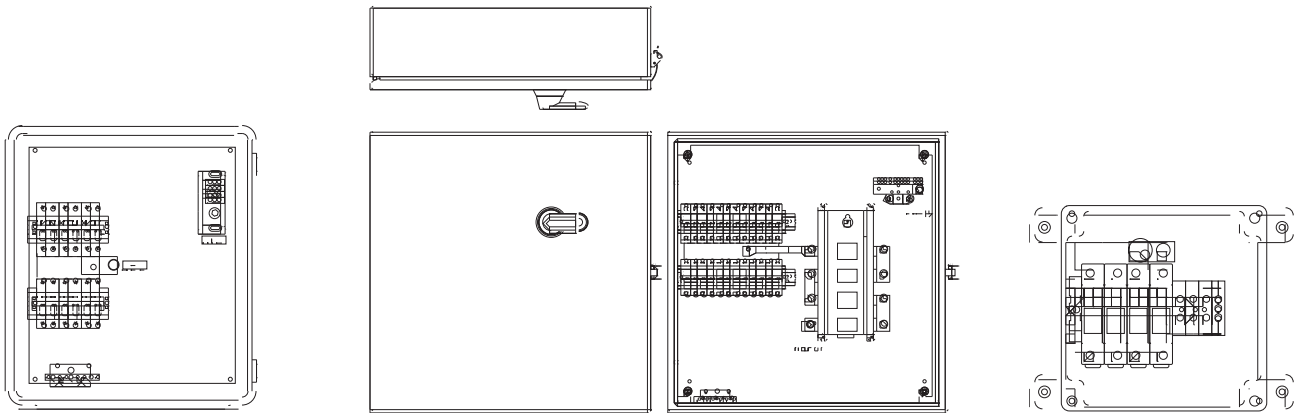

**Standard BCBS Series**

4 to 24 Circuits - BCBS-12-00F Pictured

**Integral Disconnect on BCBD Series**

4 to 24 Circuits - BCBD245-24-00R Pictured

**Compact BCBC Series**

2 to 6 Circuits - BCBC-4-00P Pictured



## Quik-Spec™ Safety Switch

Cooper Bussmann® Quik-Spec™ Safety Switch



### Specifications

Description: The new Cooper Bussmann® Quik-Spec™ Safety Switch equipped with finger-safe Low-Peak® CUBEFuse® provides superior safety and reliability for industrial customers.

Utilizing the Cooper Bussmann Class CF Low-Peak CUBEFuse, the Quik-Spec Safety Switch provides Class J fuse performance characteristics that can help mitigate incident energy and arc-flash hazard, and offers excellent component protection.

The Cooper Bussmann CUBEFuse requires no tools to install or replace.

### Agency Information:

- UL 98 standard for enclosed deadfront switches.
- UL 50 standard for enclosures for electrical equipment.
- NEMA KS 1.
- UL Listed, File E5239.
- cUL Listed to C22.2 No.4-M89.

### Standard Features:

- Extended line terminal shield and finger-safe 30, 60, or 100A Cooper Bussmann CUBEFuse
- 200kA short-circuit current rating
- Visible double break quick-make, quick-break rotary blade mechanism
- Triple padlocking capability
- Mechanically interlocked door
- 600Vac/250Vdc maximum

### Optional Features:

- Viewing window for visible blades and open fuse indication
- NEMA 1, 3R, 12, 4X (stainless)
- Suitable for use as service equipment (with neutral kit)

### Features and Benefits:

- Enhanced Finger-Safe Design  
The Cooper Bussmann Class CF CUBEFuse isolates live electrical parts from accidental contact to increase safety. Large line-side shield is standard in all models virtually eliminating accidental contact with live parts.
- Current-Limiting Fuses Reduce Arc-Flash Hazard  
with Class J fuse performance characteristics, the Quik-Spec Safety Switch offers industry best arc-flash protection versus traditional models.
- Meets UL and NEC® Requirements  
The Quik-Spec Safety Switch is rated 200kA which makes it easier to comply with NEC® 110.9 and 110.10 requirements and is listed to UL 98 and UL 50 standards.
- Flange Operated Handle  
Always in contact with the switch mechanism, the flange operated switch is preferred in most industries.
- Easy Interface with Viewing Window Option  
Window provides visual verification that switch contacts have operated, plus the ability to view fuse indication without opening the switch door.
- No Tools Required for Fuse Removal  
Reduce downtime and potential arc-flash hazard.
- Flexibility of Application  
The 600V heavy-duty safety switch is available up to 100A with NEMA 1, 3R, 12 and 4X enclosures.

Dimensions - inches (mm)\*

NEMA 1 & 3R

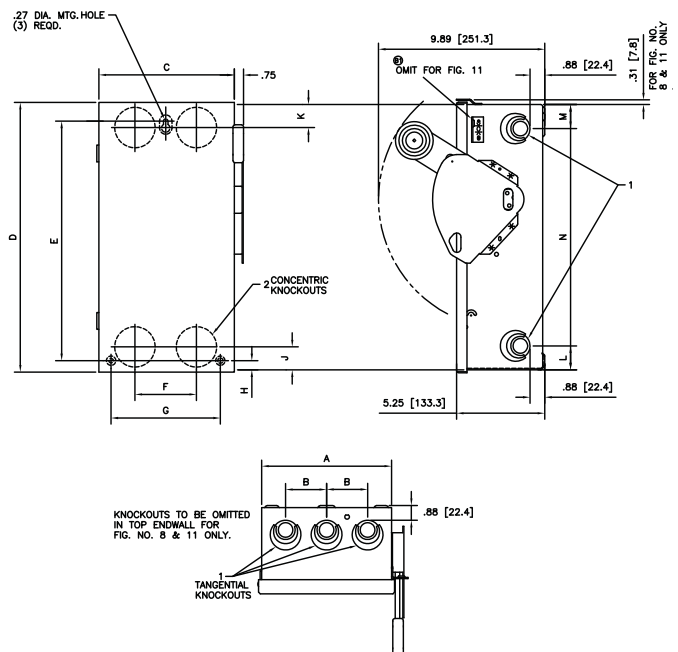

\*See Data Sheet 1156 for 4X and 12 dimension information

# Quik-Spec™ Safety Switch

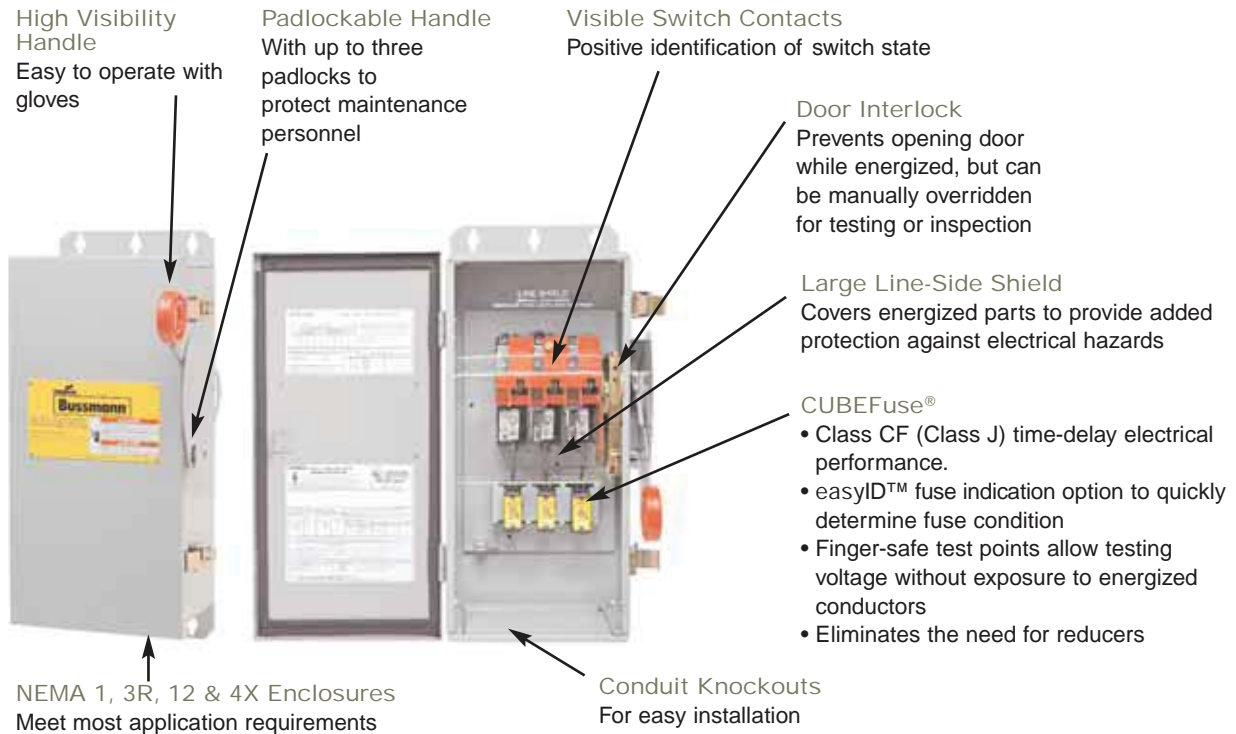

## Quik-Spec™ Safety Switch Catalog Numbering System

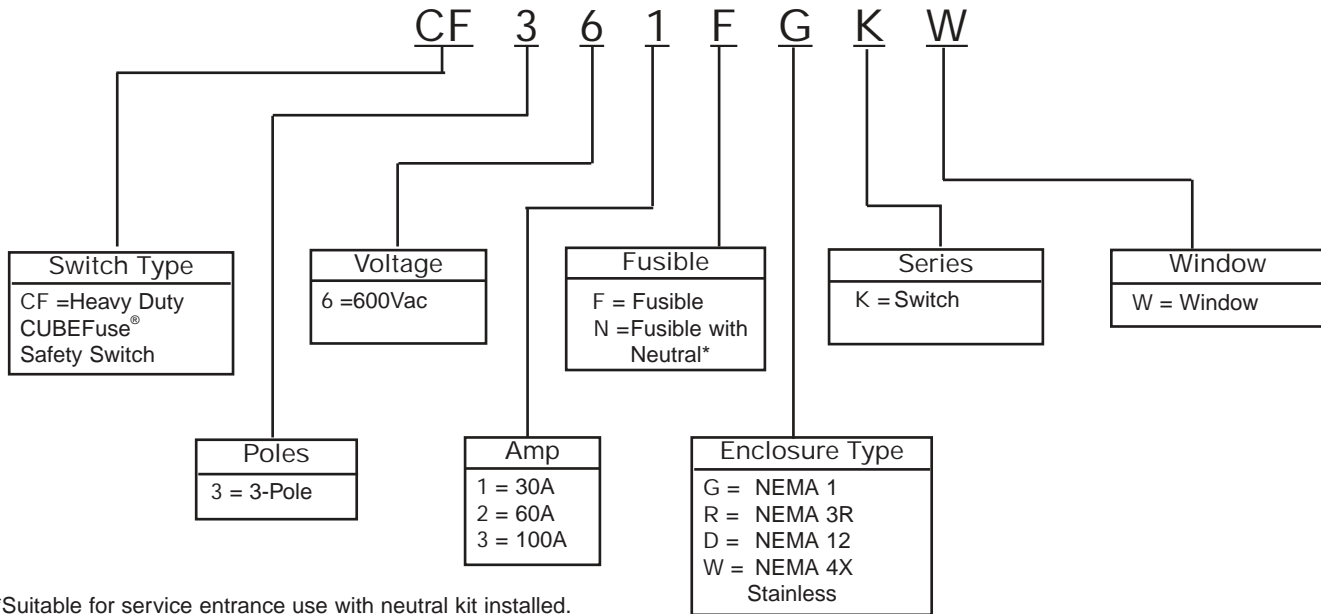

Maximum Horsepower Ratings

System	Amp Rating	Fuse Class (Performance)	Single-Phase		Three-Phase		Direct Current 250Vdc
			480Vac	600Vac	480Vac	600Vac	
3-Pole	30	Class CF CUBEFuse (Class J)	7½	10	10	15	5
	60	Class CF CUBEFuse (Class J)	20	25	30	30	10
	100	Class CF CUBEFuse (Class J)	30	40	50	50	15

## A/C Disconnects — Fused and Non-fused

### Series B22\_\_

#### Specifications

Description: Fused and non-fused rainproof air conditioner pullout units.

Dimensions: See Catalog Numbers table.

Construction: NEMA 3R rainproof metal housing with weather resistant coating.

Wire Range: 14-3 AWG, Al/Cu

#### Ratings:

Phase: — Single, 2-wire

Volts: — 240Vac

Amps: — 30-60A

Agency Information: UL Listed to UL 1429, C-UL Certified, UL Guide WGEW

#### Features and Benefits

- A/C disconnects meet NEC® Code Requirements under articles 440.14. GFCI units meet NEC® Code Requirements under articles 210.63, 210.8, and 406.8(B)(1).
- NEMA 3R rainproof enclosures withstand outdoor environment.
- Padlockable with two-position pullout handle to lock safety shield when in the ON position. (Not available on GF or NA units.) For added safety, pullout handle can be stored in the compartment in the off position.

#### Typical Applications

- Residential, light industrial/commercial A/C and heat pump service.
- Spas/whirlpools, swimming pools, pump houses
- Suitable for service entrance equipment applications with field installable ground bar, kit number DPFG.



Metallic Fused Disconnect

Metallic Non-Fused Disconnect

Metallic Non-Fused Disconnect with Weather Resistant-Tamper Resistant GFCI Receptacle.



B222-60NF34W non-fused with cable whip

### Catalog Numbers

#### Fused

Catalog Numbers	Description	Disconnect Rating	Max Hp Rating		Wire Range 60 or 75°C CU/AL	Enclosure Type	Fuse Class	Approx. Dimensions (in)		
			120V	240V				Height	Width	Depth
B221-30F	30A, Pullout	30A	1.5	3	#14-3	NEMA 3R	H or R	8 3/4	5 3/8	2 3/8
B221-30FGF	30A, Pullout w/ GFCI	30A	1.5	3	#14-3	NEMA 3R	H or R	13	7 1/2	4 3/8
B221-30FGFWRTR	30A, Pullout w/ WRTR-Rated GFCI	30A	1.5	3	#14-3	NEMA 3R	H or R	13	7 1/2	4 3/8
B222-60F	60A, Pullout	60A	3	10	#14-3	NEMA 3R	H or R	8 3/4	5 3/8	2 3/8
B222-60FGF	60A, Pullout w/ GFCI	60A	3	10	#14-3	NEMA 3R	H or R	13	7 1/2	4 3/8
B222-60FGFWRTR	60A, Pullout w/ WRTR-Rated GFCI	60A	3	10	#14-3	NEMA 3R	H or R	13	7 1/2	4 3/8
<b>Non-Fused</b>										
B222-60NF	60A, Pullout	60A	3	10	#14-3	NEMA 3R	*	8 3/4	5 3/8	2 3/8
B222-60NFGF	60A, Pullout w/ GFCI	60A	3	10	#14-3	NEMA 3R	*	11 3/4	6 1/2	4 1/2
B222-60NFGFWRTR	60A, Pullout w/ WRTR-Rated GFCI	60A	3	10	#14-3	NEMA 3R	*	11 3/4	6 1/2	4 1/2
B222-60NFNA	60A, Switch	60A	*	10	#14-3	NEMA 3R	*	8 3/4	5 3/8	3 3/8
<b>Non-Fused Cable Whip</b>										
B222-60NF12W	60A, Pullout w/ 1/2" Cable Whip	60A*	3	10	#14-3	NEMA 3R	*	14 3/4	12 1/2	4
B222-60NF34W	60A, Pullout w/ 3/4" Cable Whip	60A**	3	10	#14-3	NEMA 3R	*	14 3/4	12 1/2	4

#### Cable Whip Specifications

Catalog Numbers	Description	Pullout Rating	Max Upstream Wire Overcurrent Protection Device	Harness Diameter	Ground Wire Size	Hot Wire Size	Flexible Wire Size	Conduit Length (ft)	Non-Metallic Fittings
									1 - 90°, 1 - Straight
B222-60NF12W	60A, Pullout w/ 1/2" Cable Whip	60A	30A	1/2"	#10	#10	#10	6	1 - 90°, 1 - Straight
B222-60NF34W	60A, Pullout w/ 3/4" Cable Whip	60A	50A	3/4"	#8	#10	#10	6	1 - 90°, 1 - Straight

\* Upstream overcurrent protection device (OCPD) not to exceed 30 Amps.

\*\*Upstream overcurrent protection device (OCPD) not to exceed 50 Amps.

30 and 60A pullout replacement handle: 96-3258-4.

Data Sheet: 1143



**Fuse Holders and Blocks**  
New Finger-Safe Designs Make Fuse Applications Safer and More Flexible –  
Now Up to 1000Vdc