

WALL-MOUNT RACKS

Protect your electronics with space-saving Pentair Technical Products' Hoffman brand wall-mount racks, ideal for securing network wiring, hubs, concentrators, patch panels and audio/video equipment anywhere full-size cabinets could block traffic or airflow.

Featured Products -

SWING-OUT RACK EASILY FACILITATES FUTURE EXPANSIONS

Short on space? The 19-in. Swing-Out Rack offers a convenient solution for smaller networking equipment such as telephone and voice mail, routers, switches, punch-down panels and patch panels. This rack is designed to facilitate component installation and future expansion without disturbing existing equipment or cabling.



19-IN. SWING-OUT RACK



Chapter Contents

19-in. Wall-Mount Cabinets, Racks and Panels

- 19-in. Hinged Wall-Mount Panel178
- 19-in. Swing-Out Wall-Mount Rack179
- 19-in. Bottom-Hinged Panel180
- 19-in. Fixed Wall-Mount Rack180
- 19-in. Side-Mount Cabinet181

HINGED WALL-MOUNT PANEL SAVES SPACE

The 19-in. Hinged Wall-Mount Panel provides a solution for smaller networking equipment in areas where floor space is at a premium. It is ideal for telephone, punch-down and patch panels. Easy access combined with minimal assembly facilitates component installation and future expansion without disturbing existing equipment or cabling.

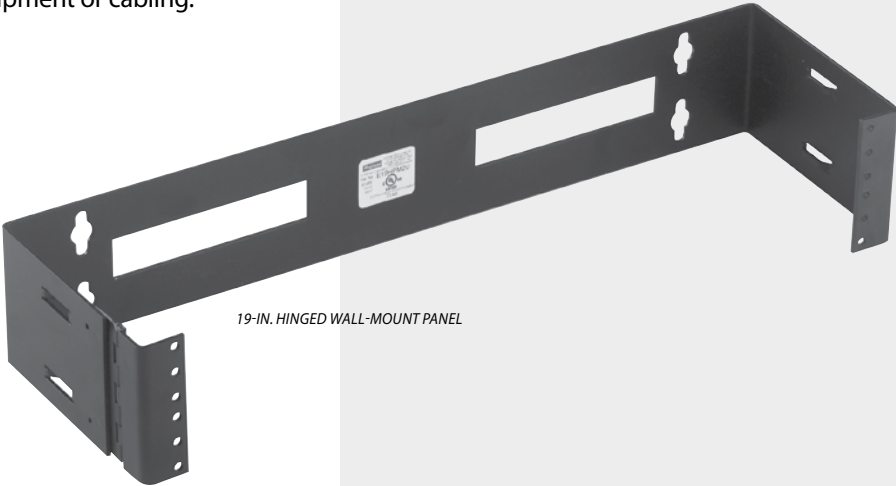

19-IN. HINGED WALL-MOUNT PANEL

19-in. Wall-Mount Cabinets, Racks and Panels

19-in. Hinged Wall-Mount Panel

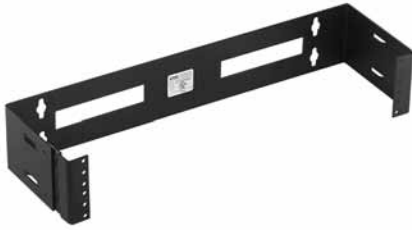

Industry Standards

UL 1863 Listed; File No. E230874
 cUL Listed per CSA C22.2 No. 182.4; File No. E230874

EIA 310-D

Application

The 19-in. Hinged Panel provides a solution for smaller network equipment, punch-downs and patch panels in areas where floor space is at a premium. Easy access facilitates component installation and future expansion without disturbing existing equipment or cabling. Can be mounted with hinges on left or right side.

Features

- Open design offers unrestricted airflow
- Large cable exit holes on back surface
- Keyhole mounting slots on 16-in. centers accommodate up to 3/8-in. dia. mounting fasteners (not supplied)
- Heavy duty hinges are welded to frame
- Hinge provided for every two rack unit spacing
- One rack unit model has half-size hinge
- Provides access to rear of equipment
- 12-24 rack mounting screws (package of 20) included with assembly
- Wall mounting hardware not included

Specifications

- Made of 12 gauge steel
- EIA universal 5/8, 5/8, 1/2 in. spaced 12-24 tapped holes. EIA spacing provides 1.75 in. per rack unit.

Finish

Finish is RAL 9005 black low-gloss polyester powder paint

Bulletin: DOFRW

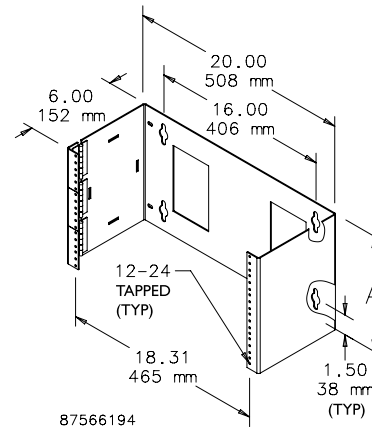

Standard Product

Catalog Number	A (in.)	A (mm)	Load Rating (lb.)	Load Rating (kg)	Rack Units
E19HPM1U	1.75	44	25	11.3	1
E19HPM2U	3.50	89	50	22.7	2
E19HPM4U	8.00	203	100	45.4	4
E19HPM6U	10.50	267	150	68.0	6
E19HPM8U	14.00	356	200	90.7	8

19-in. Wall-Mount Cabinets, Racks and Panels

19-in. Swing-Out Wall-Mount Rack



Specifications

- Made of 16 gauge steel with a lightweight welded 12 gauge steel rack
- EIA universal 5/8, 5/8, 1/2 in. spaced 12-24 tapped holes. EIA spacing provides 1.75 in. per rack unit.
- 12-24 rack mounting screws (package of 20) included with assembly
- Wall mounting hardware not included

Finish

Finish is RAL 9005 black low gloss polyester powder paint

Bulletin: DOFRW

Industry Standards

EIA 310-D

UL 1863 Listed; File No. E230874
cUL CSA C22.2 No. 182.4 Listed; File No. E230874

Application

The 19-in. Swing-Out Rack provides a solution for smaller networking equipment, punch-downs and patch panels in areas where floor space is at a premium. The pivoting, removable door provides easy access for upgrades and maintenance and facilitates future expansion without disturbing existing equipment or cabling.

Features

- Rack construction provides unrestricted airflow and easy access
- Large cable exit holes on back surface facilitate hook-up
- Keyhole mounting slots on 16 in. centers accommodate up to 3/8 in. dia. mounting fasteners (not supplied)
- Integral VELCRO® cable tiedown slots help manage strain relief and large radius service loops
- Pivoting, removable rack door provides access to rear of equipment and cable for upgrades and maintenance

VELCRO is a registered trademark of Velcro Industries B.V.

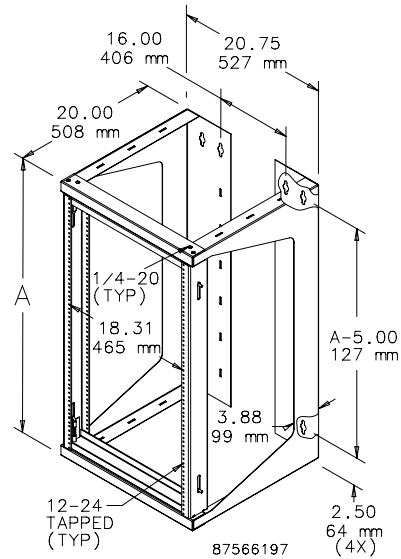

Standard Product

Catalog Number	A in.	A mm	Load Rating (lb.)	Load Rating (kgs)	Rack Units
E19SWM12U20	25.50	648	100	45.4	12
E19SWM20U20	39.50	1003	150	68.0	20
E19SWM25U20	48.25	1226	175	79.4	25
E19SWM32U20	60.50	1537	200	90.7	32

19-in. Wall-Mount Cabinets, Racks and Panels

19-in. Bottom-Hinged Panel



Hinged panel pivots to 90 degrees with positive stop, providing a stable platform for punch-down interconnects. Thumbscrews secure the panel in the upright position. Integral VELCRO® cable tiedown slots facilitate cable routing. Cover protects equipment and cables. Made of 12 gauge steel on hinged swing-out frame; 16 gauge on body. Finished with RAL 9005 low gloss black polyester powder paint. Shipped fully assembled.

VELCRO® is a trademark of Velcro Industries B.V.

Bulletin: DOFRW

Catalog Number	A (in.)	A (mm)	Load Rating (lb.)	Load Rating (kgs)	Rack Units
E19BHPM4U12	8.00	203	25	11.3	4
E19BHPM6U12	10.50	267	50	22.7	6
E19BHPM8U12	14.00	356	50	22.7	8

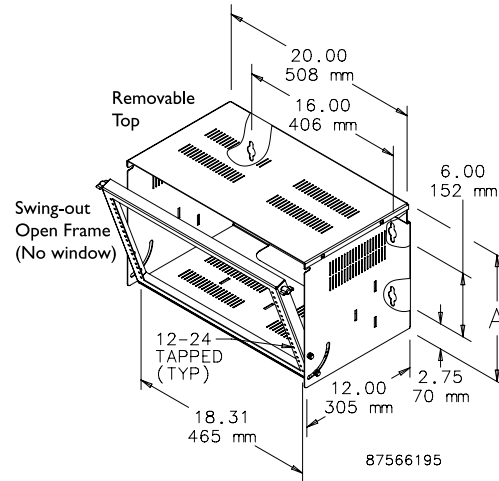

19-in. Fixed Wall-Mount Rack



Economical solution for banks of small networking equipment. Integral VELCRO® cable tiedown slots facilitate cable routing. Made of 16 gauge steel, finished with RAL 9005 low gloss black polyester powder paint. Shipped in four easy-to-assemble sections.

VELCRO is a trademark of Velcro Industries B.V.

Bulletin: DOFRW

Catalog Number	A (in.)	A (mm)	Load Rating (lb.)	Load Rating (kg)	Rack Units
E19FWM12U20	23.00	584	150	68.0	12
E19FWM20U20	37.00	940	150	68.0	20
E19FWM25U20	45.75	1162	150	68.0	25
E19FWM32U20	58.00	1473	150	68.0	32

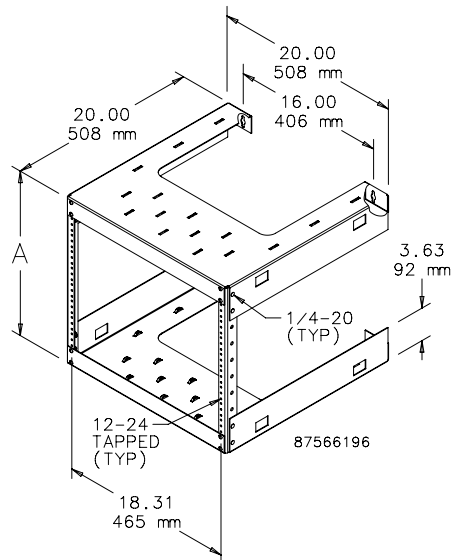

19-in. Wall-Mount Cabinets, Racks and Panels

19-in. Side-Mount Cabinet



Equipment mounts sideways against the wall; ideal for applications where a low profile is required. Easily removable front cover protects equipment. Integral VELCRO® cable tiedown slots facilitate cable routing. Made of 16 gauge steel, finished with RAL 9005 low gloss black polyester powder paint. Shipped fully assembled.

VELCRO is a trademark of Velcro Industries B.V.

Bulletin: DOFRY

Catalog Number	C (in.)	C (mm)	Load Rating (lb.)	Load Rating (kgs)	Rack Units
E19SM2U	3.50	89	50	22.7	2
E19SM4U	7.00	178	50	22.7	4

