

Table of Contents

Section 3

Safety Switches



General Duty, p. 3-2



Light Duty, p. 3-2



Heavy Duty, p. 3-4



Stainless Steel Heavy Duty, p. 3-7

General Duty

Fusible and Non-Fusible	3-2
Application Data and Dimensions	3-3
Standards:	
<ul style="list-style-type: none"> • UL 98 Enclosed and Dead Front Switches. UL Listed under File E2875. • NEMA Standards Publication KS1. Enclosed Switches. 	

Light Duty

Fusible	3-2
Application Data and Dimensions	3-3
Standards:	
<ul style="list-style-type: none"> • UL 98 Enclosed and Dead Front Switches. UL Listed under File E2875. • NEMA Standards Publication KS1. Enclosed Switches. 	

Heavy Duty

Fusible	3-4
Non-Fusible	3-6
Special Application Enclosures	3-7
<i>New!</i> Motor Disconnect and Receptacle Switches	3-8
Accessories	3-11
Application Data and Dimensions	3-14
Standards:	
<ul style="list-style-type: none"> • UL 98 Enclosed and Dead Front Switches. UL Listed under files E2875, E154828, E233505 and E317818. • UL 508 Industrial Control Equipment. • NEMA Standards Publication KS1 Enclosed Switches (UL98 Switches Only). 	

Double Throw

Fusible and Non-Fusible	3-16
Accessories	3-19
Standards:	
<ul style="list-style-type: none"> • UL 98 Enclosed and Dead Front Switches. UL Listed under files E2875 (unless otherwise noted). • NEMA Standards Publication KS1 Enclosed Switches (applies to Type DT and DTU series F only). 	
Application Data and Dimensions	3-20



by Schneider Electric

© 2009 Schneider Electric
All Rights Reserved





C223N

General Duty—Up To 100 kA Short Circuit Current Rating With Proper Current Limiting Fusing

General duty safety switches are designed for residential and commercial applications where durability and economy are prime considerations. Typical loads are lighting, air conditioning, and appliances. They are suitable for use as service equipment when equipped with a factory- or field-installed neutral assembly or a field-installed service grounding kit, as applicable.

General duty safety switches are UL Listed, File E2875, and meet or exceed the NEMA Standard KS1. 400 and 600 A general duty switches (NEMA 1 only) will accept Class J fuses and are UL Listed for use on systems with up to 100 kA available fault current. 600 A requires Class J fuse kit—GDJK600 (page 3-3). 400 A requires moving load base.

Class T 400–800 A general duty safety switches use 300 Vac Class T fuses and are UL Listed for use on systems with up to 100 kA available fault current.

UL Listed Short Circuit Withstand Rating		
Switch Type	Fuse Class	Short Circuit Rating
Fusible	Plug	10 kA
	H	10 kA
	K	10 kA
	J	100 kA
	R	100 kA
Non-Fusible▲	T	100 kA
	H	10 kA
	K	10 kA
	J	100 kA
	R	100 kA■
	T	100 kA

▲ The UL Listed short-circuit current rating for Square D general duty, not fusible switches is based on the switch being used in conjunction with fuses. Evaluation of non-fusible switches in conjunction with molded case circuit breakers has not been performed. For applications requiring greater protection, consider using a heavy duty safety switch. Refer to UL Listed Maximum Short Circuit Current Ratings—AC only—on page 3-6. If a UL Listed short-circuit current rating is required, this non-fusible switch must be replaced with a Square D general duty fusible safety switch equipped with the appropriate class and size fusing. The UL Listed short-circuit current rating of the fusible switch is typically as follows: when used with Class H and K fuses—10,000 A, Class R and J fuses—100,000 A. Consult the wiring diagram of the switch to verify the UL Listed short-circuit current rating.

■ 50 kA for 60 A non-fusible switch.

Table 3.1: Fusible

System	A	Fuse	NEMA 1 Indoor		NEMA 3R▲ Rainproof		Class R Fuse Kits Field-Installed■		Horsepower Ratings			
			Cat. No.	\$ Price	Cat. No.	\$ Price	Cat. No.	\$ Price	Std. (Fast Acting One-Time Fuses)		Max. (Dual Element Time-Delay Fuses)	
									1Ø	3Ø	1Ø	3Ø
2 Wire (1 Blade and Fuseholder, 1 Neutral)—120 Vac												
	30	Plug	Use Light Duty Device for this Application (see below)									
	30	Cart.	Use three-wire devices for this application.									
3 Wire (2 Blades and Fuseholders, 1 Neutral)—120/240 Vac (Plug), 240 Vac (Cart.) Maximum												
	30	Plug	D211N	90.00	D211NRB	177.00	—	—	1-1/2	—	3	—
	30	Cart.	D221N	122.00	D221NRB	188.00	DRK30	25.65	1-1/2	3♦	3	7-1/2♦
	60	Cart.	D222N	206.00	D222NRB	326.00	RFK03H	25.50	3	7-1/2♦	10	15♦
	100	Cart.	D223N	426.00	D223NRB	480.00	RFK10	47.70	7-1/2	15♦	15	30♦
	200	Cart.	D224N▼	884.00	D224NRB▼	1200.00	HRK1020	47.70	15	25♦	—	60♦
	400	Cart.	D225N	2555.00	D225NR	3459.00	DRK40	111.00	—	—	—	—
	600	Cart.	D226N	5109.00	D226NR	6569.00	DRK600	111.00	—	—	—	—
4 Wire (3 Blades and Fuseholders, 1 Neutral)—240 Vac Maximum												
	30	Cart.	D321N	188.00	D321NRB	293.00	DRK30	25.65	1-1/2	3	3	7-1/2
	60	Cart.	D322N	326.00	D322NRB	441.00	RFK03H	25.50	3	7-1/2★	10	15★
	100	Cart.	D323N	564.00	D323NRB	816.00	RFK10	47.70	7-1/2	15★	15	30★
	200	Cart.	D324N▼	1202.00	D324NRB▼	1461.00	HRK1020	47.70	15	25★	—	60★
	400	Cart.	D325N	3113.00	D325NR	3893.00	DRK40	111.00	—	50	—	125
	400	Class T	D325NT	2994.00	D325NTR	3741.00	—	—	—	50	—	—
	600	Cart.	D326N	5823.00	D326NR	7877.00	DRK600	111.00	—	75	—	150
	600	Class T	D326NT	5598.00	D326NTR	7569.00	—	—	—	75	—	—
800	Class T	T327N	9722.00	T327NR	12438.00	—	—	—	100	—	—	

- ▲ Bolt-on hubs—Refer to page 3-11.
- When installed, this kit rejects all but Class R fuses.
- ♦ For corner grounded delta systems only. Use switching poles for ungrounded conductors.
- ★ If corner grounded delta, use outer switching poles for ungrounded conductors.
- ▼ For 200% neutral, order (1) additional neutral kit SN20A and (1) neutral jumper kit SN20NI.

Table 3.2: Non-Fusible

System	A	NEMA 1 Indoor		NEMA 3R Rainproof ▲		Horsepower Ratings (Max.)	
		Cat. No.	\$ Price	Cat. No.	\$ Price	1Ø	3Ø
2 Wire (2 Blades)—240 Vac Maximum							
	30	—	—	DU221RB	177.00	3	—
	60	—	—	DU222RB	353.00	10	—
	60	QO260NATS□♦	161.00	QO200TR□♦★	161.00	10	—
	100	QO2000NS□♦	276.00	QO2000NRB□★	338.00	20	—
	200	Use 3P Switch	—	Use 3P Switch	—	—	—
	400	Use 3P Switch	—	Use 3P Switch	—	—	—
3 Wire (3 Blades)—240 Vac Maximum							
	30	DU321	155.00	DU321RB	293.00	3	7-1/2
	60	DU322	206.00	DU322RB	443.00	10	15
	100	DU323▼	477.00	DU323RB▼	816.00	15	30
	200	DU324◊	884.00	DU324RB◊	1461.00	15	60*
	400	DU325	2198.00	—	—	—	125
	600	DU326*	4191.00	—	—	—	150

- ▲ Bolt-on hubs—Refer to page 3-11.
- Enclosed molded case switch—Refer to page 1-24.
- ♦ Includes factory-installed grounding kit.
- ★ Not service entrance rated—Refer to page 1-19 for more information.
- ▼ If a neutral assembly is required, order and field-install SN0610.
- ◊ If a neutral assembly is required, order and field install a SN20A Neutral Assembly Kit. For a 200% neutral application, order and field install (2) SN20A Neutral Assembly Kits and (1) SN20NI Neutral Jumper Kit.
- * If a neutral assembly is required, order part number D600SN. Available for field-installation.

Light Duty—Visible Blades 10 kA Short Circuit Current Rating

The Square D light duty enclosed switch is ideal for home applications in disconnecting power to workshops, hobby rooms, furnaces, and garages.

Table 3.3: Fusible

System	Rating (A)	Fuse	NEMA 1 Indoor		Horsepower Ratings		System	A	Fuse	NEMA 1 Indoor		Horsepower Ratings	
			Cat. No. ◊	\$ Price	Std.	Max.				Cat. No. ◊	\$ Price	Std.	Max.
2 Wire (1 Blade and Fuseholder, 1 Neutral)—120 Vac													
	30	Plug	L111N	\$54.00	1/2	2	3 Wire (2 Blades and Fuseholders, 1 Neutral)—120/240 Vac						
							30	Plug	L211N	72.00	1-1/2◊	3◊	
							30	Cart.	L221N	98.00	1-1/2◊	3◊	

- ◊ For single phase hp rating, use two switching poles.
- ◊ DE1A Discount Schedule.



L221N

Field-Installed Electrical Interlock Kits

Electrical interlocks for Series F 100–200 A general duty safety switches and Series F 60 A fusible general duty safety switches are available in kit form for field installation. Each kit contains instructions for proper field mounting. A pivot arm operates from switch mechanism, breaking the control circuit before the main switch blades break. Switches with electrical interlocks installed are UL Listed.

Table 3.4: Electrical Interlock Kit

Switch Rating (A)	Electrical Interlock Kit Cat. No.▲	\$ Price
Fusible Series F 60	EIK031 or EIK032	218.00
Series F 100–200	EIK1 or EIK2	311.00

▲ Electrical interlock kit catalog numbers with -1 suffix indicates one normally open and one normally closed contact; -2 indicates two normally open and two normally closed contacts. Kits are UL Listed.

Field-Installed Fuse Puller Kits

Kit consists of three fuse pullers as required for a 3P, fusible, 60 and 100 A general duty switch. Kits can be installed in 60 and 100 A Series F switches.

Description	Cat. No.	\$ Price
Series F 60 A Fuse Puller Kit	FPK03	30.00
Series F 100 A Fuse Puller Kit	FPK0610	42.60

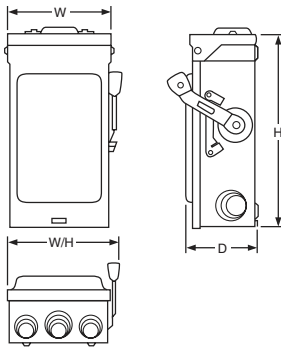

Table 3.7: Approximate Dimensions

Cat. No.	Series	H		W		W/H		D		Std. Pack
		in.	mm	in.	mm	in.	mm	in.	mm	
L111N	E2	7.63	194	5.00	127	6.13	156	4.00	102	1
L211N	E2	7.63	194	5.00	127	6.13	156	4.00	102	1
L221N	E2	7.63	194	5.00	127	6.13	156	4.00	102	1
D211N♦	E3	9.25	235	6.75	171	7.25	184	3.63	92	5
D211NRB♦	E2	9.63	245	7.25	184	7.75	197	3.75	95	5
D221N♦	E3	9.25	235	6.75	171	7.25	184	3.63	92	5
D221NRB♦	E3	9.63	245	7.25	184	7.75	197	3.75	95	5
D222N	F1	14.63	372	6.50	165	7.45	189	4.88	124	1
D222NRB	F1	14.88	378	6.63	168	7.45	189	4.88	124	1
D223N	F3	17.50	445	8.50	216	10.50	267	6.50	165	1
D223NRB	F3	17.50	445	8.50	216	10.50	267	6.50	165	1
D224N	F1	29.00	737	17.25	438	19.00	483	8.25	210	1
D224NRB	F1	29.25	743	17.25	438	19.00	483	8.25	210	1
D225N	E3	45.12	1146	24.00	610	24.88	632	8.88	226	1
D225NR	E1	30.63	778	21.38	543	22.25	565	10.13	257	1
D226N♦	E3	49.13	1248	24.00	610	24.88	632	8.88	226	1
D226NR♦	E1	49.13	1248	24.75	629	25.13	638	8.88	226	1
D321N♦	E3	9.25	235	6.75	171	7.25	184	3.63	92	5
D321NRB♦	E3	9.63	245	7.25	184	7.75	197	3.75	95	5
D322N	F1	14.63	372	6.50	165	7.45	189	4.88	124	1
D322NRB	F1	14.88	378	6.63	168	7.45	189	4.88	124	1
D323N	F3	17.50	445	8.50	216	10.50	267	6.50	165	1
D323NRB	F3	17.50	445	8.50	216	10.50	267	6.50	165	1
D324N	F1	29.00	737	17.25	438	19.00	483	8.25	210	1
D324NRB	F1	29.25	743	17.25	438	19.00	483	8.25	210	1
D325N♦	E3	45.12	1146	24.00	610	24.88	632	8.88	226	1
D325NT♦	E3	45.12	1146	24.00	610	24.88	632	8.88	226	1
D325NR♦	E1	30.63	778	21.38	543	22.25	565	10.13	257	1

♦ 30–100 A switches suitable for 60°C or 75°C conductors. 200–800 A switches suitable for 75°C conductors.

Table 3.5: Field-Installed Service Grounding Kits

Switch Rating (A)	Cat. No.	\$ Price	Wire Size (AWG)
30	PK3GTA1	11.40	(2) 12 Cu or (2) 10 Al or (1) 4 Al/Cu Max.
Series E 60	PK3GTA1	11.40	(2) 12 Cu or (2) 10 Al or (1) 4 Al/Cu Max.
Series F 60	GTK03	11.40	(2) 12 Cu or (2) 10 Al or (1) 4 Al/Cu Max.
100	GTK0610	18.90	(2) 1/0 Al/Cu Max.
200	PKOGTA2	55.00	(2) 2/0 Al/Cu Max.
400	PKOGTA2	55.00	(2) 2/0 Al/Cu Max. Per Lug
600	(Two Required)		
800	PKOGTA3	123.00	(6) 3/0 Al/Cu Max.

Table 3.6: Terminal Lug Data

Rating (A)	Conductors Per Phase	Wire Range Wire Bending Space Per NEC Table 312.6 AWG/kcmil	Lug Wire Range AWG/kcmil
30	1	12–6 (Al) or 14–6 (Cu)	12–6 (Al) or 14–6 (Cu)
60	1	10–3 (Al) or 14–3 (Cu)	10–2 (Al) or 14–2 (Cu)
100	1	12–1 (Al) or 14–1 (Cu)	12–1/0 (Al) or 14–1/0 (Cu)
200	1	6–250 (Al/Cu)	6–300 (Al/Cu)
400 NEMA 1	1 or 2	1/0–600 (Al/Cu) or 1/0–300 (Al/Cu)	(1) 1/0–750 (Al/Cu) or (2) 1/0–300 (Al/Cu)
400 NEMA 3R	2	1/0–250 (Al/Cu)	(1) 1–600 (Al/Cu) or (2) 1/0–250 (Al/Cu)
600	2	4–500 (Al/Cu)	4–600 (Al/Cu)
800	3	3/0–500 (Al/Cu)	3/0–500 (Al/Cu)

■ 30–100 A switches suitable for 60°C or 75°C conductors. 200–800 A switches suitable for 75°C conductors.

NOTE: Field-installed lug kits are located in the Supplemental Digest page 2.2.

Cat. No.	Series	H		W		W/H		D		Std. Pack
		in.	mm	in.	mm	in.	mm	in.	mm	
D325NTR♦	E1	30.63	778	21.38	543	22.25	565	10.13	257	1
D326N♦	E3	49.13	1248	24.00	610	24.88	632	8.88	226	1
D326NT♦	E3	49.13	1248	24.00	610	24.88	632	8.88	226	1
D326NR♦	E1	49.13	1248	24.75	629	25.13	638	8.88	226	1
D326NTR♦	E1	49.13	1246	24.75	629	25.13	638	8.88	226	1
DU221RB♦	E2	9.63	245	7.25	184	7.75	197	3.75	95	5
DU222RB♦	E1	9.63	245	7.25	184	7.75	197	3.75	95	5
DU321♦	E2	9.25	235	6.75	171	7.25	184	3.63	92	5
DU321RB♦	E2	9.63	245	7.25	184	7.75	197	3.75	95	5
DU322♦	E1	9.25	235	6.75	171	7.25	184	3.63	92	5
DU322RB♦	E1	9.63	245	7.25	184	7.75	197	3.75	95	5
DU323	F3	17.50	445	8.50	216	10.50	267	6.50	165	1
DU323RB	F3	17.50	445	8.50	216	10.50	267	6.50	165	1
DU324	F1	29.00	737	17.25	438	19.00	483	8.25	210	1
DU324RB	F1	29.25	743	17.25	438	19.00	483	8.25	210	1
DU325♦	E3	45.12	1146	24.00	610	24.88	632	8.88	226	1
DU326♦	E3	49.13	1248	24.00	610	24.88	632	8.88	226	1
QO200TR♦	G3	6.50	165	4.63	118	—	—	3.88	99	5
QO260NATS♦	E2	9.25	235	4.88	124	—	—	3.25	83	1
QO200NRB♦	E1	14.00	356	7.75	197	—	—	4.50	114	1
QO200NS♦	E1	13.38	340	6.13	156	—	—	3.50	89	1
T327N♦	E1	49.13	1248	24.00	610	24.88	632	8.88	226	1
T327NR♦	E1	49.13	1248	24.75	629	25.13	638	8.88	226	1

SAFETY SWITCHES

Table 3.9: 600 Volts—Single Throw Fusible

System	Amperes	NEMA 1 Indoor		NEMA 3R Rainproof (Bolt-on Hubs, page 3-11)		NEMA 4, 4X, 5▲ 304 Stainless Steel (for 316 stainless, see page 3-7) Dust tight, Watertight, Corrosion Resistant (Watertight Hubs, page 3-11)		NEMA 12K With Knockouts (Watertight Hubs, page 3-11)		NEMA 12, 3R■ Without Knockouts (Watertight Hubs, page 3-11)		Horsepower Ratings♦				dc▼			
		Cat. No.		\$ Price		Cat. No.		\$ Price		Cat. No.		\$ Price		480 Vac		600 Vac		250	600
		Std. (Using Fast Acting, One Time Fuses)	Max. (Using Dual Element, Time Delay Fuses)	Std. (Using Fast Acting, One Time Fuses)	Max. (Using Dual Element, Time Delay Fuses)	3Ø	3Ø	3Ø	3Ø										
2-Wire (2 Blades and Fuseholders)—600 Vac, 600 Vdc																			
	30	Use three-wire devices for two-wire applications										—	—	—	—	—	—		
	60											—	—	—	—	—	—		
	100											—	—	—	—	—	—		
	200											—	—	—	—	—	—		
	400	H265	4206.00	H265R	5424.00	H265DS	14961.00	—	—	H265AWK	5025.00	100★	250★	—	—	—	50	50	
	600	H266	6653.00	H266R	10686.00	H266DS	21399.00	—	—	H266AWK	7341.00	150★	400★	—	—	—	50	50	
800	H267	10365.00	H267R	16385.00	—	—	—	—	H267AWK	15276.00	—	—	—	—	—	50	50		
1200	H268	14570.00	H268R	17991.00	—	—	—	—	H268AWK	18044.00	—	—	—	—	—	50	50		
3-Wire (3 Blades and Fuseholders)—600 Vac, 600 Vdc▼																			
	30	H361	528.00	H361RB	899.00	H361DS	2520.00	H361A	1014.00	H361AWK	956.00	5	15	7-1/2	20	5	15		
	30	H361-2Δ	617.00	H3612RBΔ	1049.00	—	—	H361-2AΔ	1035.00	H3612AWKΔ	977.00	5	15	7-1/2	20	—	15		
	60	H362	638.00	H362RB	1055.00	H362DS	2771.00	H362A	1047.00	H362AWK	984.00	15	30	15	50	—	30		
	100	H363	1188.00	H363RB	1644.00	H363DS	5493.00	H363A	1626.00	H363AWK	1539.00	25	60	30	75	—	50		
	200	H364	1707.00	H364RB	2259.00	H364DS	7685.00	H364A	2544.00	H364AWK	2400.00	50	125	60	150	40	50		
	400	H365	4551.00	H365R	5532.00	H365DS	15321.00	—	—	H365AWK	5462.00	100	250	125	350	50	50		
	600	H366	7649.00	H366R	10899.00	H366DS	21084.00	—	—	H366AWK	9203.00	150	400	200	500	50	50		
	800	H367	13319.00	H367R	16500.00	—	—	—	—	H367AWK	16352.00	200	500	250	500	50	50		
	1200	H368	17507.00	H368R	20009.00	—	—	—	—	H368AWK	19706.00	200	500	250	500	50	50		
	4-Wire (3 Blades and Fuseholders, 1 Neutral)—600 Vac, 600 Vdc▼																		
	30	H361N	617.00	H361NRB	986.00	Use three-wire devices field-installed solid neutral assemblies. Order separately. See page 3-12.					5	15	7-1/2	20	—	15			
	60	H362N	710.00	H362NRB	1134.00						15	30	15	50	—	30			
	100	H363N	1278.00	H363NRB	1737.00						25	60	30	75	—	50			
	200	H364N	1869.00	H364NRB	2408.00	H364NDS	7871.00	H364NA	2715.00	H364NAWK	2558.00	50	125	60	150	40	50		
	400	H365N	4898.00	H365NR	5765.00	H365NDS	15668.00	—	—	H365NAWK	5823.00	100	250	125	350	50	50		
	600	H366N	8019.00	H366NR	11054.00	H366NDS	22122.00	—	—	H366NAWK	9600.00	150	400	200	500	50	50		
	800	H367N	14043.00	H367NR	17205.00	—	—	—	—	H367NAWK	17253.00	200	500	250	500	50	50		
	1200	H368N	18114.00	H368NR	20993.00	—	—	—	—	H368NAWK	20820.00	200	500	250	500	50	50		
	4-Wire (4 Blades and Fuseholders)—600 Vac, 600 Vdc◇																		
		30	H461	914.00	—	—	H461DS	2937.00	—	—	H461AWK	1115.00	7-1/2	20	10	25	5	15	
60		H462	1065.00	—	—	H462DS	3069.00	—	—	H462AWK	1257.00	15	40	20	50	10	30		
100		H463	1778.00	—	—	H463DS	8345.00	—	—	H463AWK	1932.00	25	50	30	75	20	30		
200		H464	2957.00	—	—	H464DS	12596.00	—	—	H464AWK	3222.00	50	—	50	—	40	50		
400		H465	6210.00	—	—	—	—	—	—	H465AWK	6807.00	100	250	125	350	50	50		
600		H466	10104.00	—	—	—	—	—	—	—	—	150	400	200	500	50	50		
6-Wire (6 Blades and Fuseholders)—600 Vac◇																			
	100	—	—	—	—	H663DS	25964.00	—	—	H663AWK	5112.00	25	60	30	75	—	—		
	200	—	—	—	—	H664DS	35393.00	—	—	H664AWK	12222.00	For applications requiring motor disconnect capability, use electrical interlock. Refer to page 3-11.							

- ▲ Complete rating is NEMA 3, 3R, 4, 4X, 5 and 12.
- Also suitable for NEMA 3R application by removing drain screw from bottom endwall.
- ◆ Refer to page 7-35 for additional motor application data. The starting current of motors of more than standard horsepower may require the use of fuses with appropriate time delay characteristics.
- ★ For corner grounded delta systems only and with neutral assembly installed. Use switching poles for ungrounded conductors.
- ▼ On 3P devices, use two outside poles for switching dc.
- Δ 60 A switch with 30 A fuse spacing and clips. Must use 60 A enclosure accessories including electrical interlocks.
- Suitable for NEMA 5 applications with drain screw installed.
- ◇ Not suitable for use as service equipment.

Class H Fuse Provisions:

Fusible Square D 30 through 600 A heavy duty safety switches accept Class H fuses as standard. With Class H fuses installed, the switch is UL Listed for use on systems with up to 10 kA available fault current.

Class R Fuse Provisions:

Fusible Square D 30–600 A heavy duty safety switches will accept Class R fuses as standard. A field-installed rejection kit is available which, when installed, rejects all but Class R fuses. With the installation of the rejection kit and Class R fuses, the switch is UL Listed for use on systems with up to 200 kA available fault current. See Class R fuse kits on page 3-11.

Class J Fuse Provisions:

Provisions for installing Class J fuses are included in 30 through 400 A 600 Volt, and 100 through 400 A 240 Volt, fusible heavy duty safety switches. Conversion to Class J fuse spacing requires relocating the load side fuse base assembly from the standard Class H fuse location to an alternate position as marked in the enclosure. With Class J fuses installed, the switch is UL Listed for use on systems with up to 200 kA available fault current. Switches rated 600 A, 240 or 600 Volt, require the addition of an adapter kit, H600J at \$456. One kit per 3P switch.

Class L Fuse Provisions:

Fusible 800 A and 1200 A safety switches use Class L bolt-in fuses and are rated for use on systems with up to 200 kA at 600 Vac maximum. 1200 A switches accept class L fuses from 601–1200 A, 800 A switches accept class L fuses from 601–800 A.

Accessories:pages 3-11 through 3-13
 Dimensions: NEMA 1 and 3Rpage 3-14
 Dimensions: NEMA 4, 4X and 5page 3-15

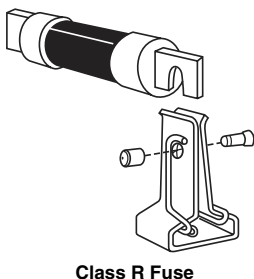

316 Grade Stainless Steel—NEMA 3, 3R, 4, 4X, 5, 12

Type 316 stainless steel enclosure safety switches offer superior corrosion resistance to a wider range of chemicals than Type 304 stainless switches. Type 316 better resists chloride and is often used in marine, waste treatment and transportation applications. Use watertight hubs from page 3-11. Equipment grounding lugs are supplied as standard.
(For Type 304 stainless switches see pages 3-4–3-6.)



H361SS

Table 3.13: 3P 600 Vac, 600 Vdc

Amperes	Cat. No	\$ Price	Horsepower Ratings—3Ø▲				
			480 Vac		600 Vac		600 Vdc■
			Std.	Max.	Std.	Max.	Max.
Fusible							
30	H361SS	3444.00	5	15	7-1/2	20	15
60	H362SS	3792.00	15	30	15	50	30
100	H363SS	7562.00	25	60	30	75	50
200	H364SS	10592.00	50	125	60	150	50
400	H365SS	13843.00	100	250	125	350	50
600	H366SS	16972.00	150	400	200	500	50
Non-Fusible							
30	HU361SS	2898.00	—	20	—	30	15
60	HU362SS	3444.00	—	50	—	60	30
100	HU363SS	7029.00	—	75	—	100	50
200	HU364SS	9623.00	—	125	—	150	50
400	HU365SS	12868.00	100	250	125	350	50
600	HU366SS	15420.00	150	400	200	500	50

Fiberglass Reinforced Polyester Enclosures—NEMA 4X

Fiberglass reinforced polyester enclosures are watertight, corrosion resistant, and impervious to windblown dust, rain, and splashing liquid. The molded fiberglass is extremely stable in a wide range of operating temperatures and can withstand heavy impact. Switches are furnished with hubs (page 3-15) and equipment grounding lugs. UL Listed.



H363DF

Table 3.14: 3P 600 Vac, 600 Vdc

Amperes	Cat. No.	\$ Price	Class R Fuse Kits		Electrical Interlock Kits Field-Installed Cat. No. ♦		Horsepower Ratings—3Ø▲				
			Cat. No.	\$ Price	1 NO/1 NC Contact	2 NO/2 NC Contacts	480 Vac		600 Vac		600 Vdc■
							Std.	Max.	Std.	Max.	Max.
Fusible											
30	H361DF	3570.00	RFK06	25.50	9999TC10	9999TC20	5	15	7-1/2	20	15
60	H362DF	3968.00	RFK06H	25.50	9999TC10	9999TC20	15	30	15	50	30
100	H363DF	7613.00	RFK10	47.70	9999TC10	9999TC20	25	60	30	75	50
200	H364DF★	9729.00	HRK1020	47.70	9999R8	9999R9	50	125	60	150	50
Non-Fusible											
30	HU361DF	3402.00	—	—	9999TC10	9999TC20	—	20	—	30	15
60	HU362DF	3782.00	—	—	9999TC10	9999TC20	—	50	—	60	30
100	HU363DF	7241.00	—	—	9999TC10	9999TC20	—	75	—	100	50
200	HU364DF★	9695.00	—	—	9999R8	9999R9	—	125	—	—	50

Krydon® Enclosures—NEMA 4X

Krydon enclosures are compression molded of fiberglass reinforced polyester, specially formulated to withstand attack from almost any corrosive atmosphere found in the toughest industrial application. Switches are furnished with hubs (page 3-15) and equipment grounding lugs. UL Listed.



H361DX

Table 3.15: 3P, 600 Vac, 600 Vdc

Amperes	Cat. No.	\$ Price	Class R Fuse Kits		Electrical Interlock Kits Field-Installed Cat. No. ♦		Horsepower Ratings—3Ø▲				
			Cat. No.	\$ Price	1 NO/1 NC Contact	2 NO/2 NC Contacts	480 Vac		600 Vac		600 Vdc■
							Std.	Max.	Std.	Max.	Max.
Fusible											
30	H361DX	4161.00	RFK06	25.50	9999TC10	9999TC20	5	15	7-1/2	20	15
60	H362DX	4626.00	RFK06H	25.50	9999TC10	9999TC20	15	30	15	50	30
100	H363DX	8858.00	RFK10	47.70	9999TC10	9999TC20	25	60	30	75	50
Non-Fusible											
30	HU361DX	3960.00	—	—	9999TC10	9999TC20	—	20	—	30	15
60	HU362DX	4406.00	—	—	9999TC10	9999TC20	—	50	—	60	30
100	HU363DX	8438.00	—	—	9999TC10	9999TC20	—	75	—	100	50

NEMA 7 and 9

An enclosed automatic molded case switch for use in Divisions 1 and 2 of the following: Class I, Groups C and D; Class II, Groups E, F and G; or Class III, Hazardous Locations as defined in NEC® Article 500. Furnished with threaded conduit openings in both top and bottom endwall (page 3-15). Suitable for use as service equipment and listed as "Raintight" for outdoor applications. UL Listed, and CSA Certified. Equipment grounding lugs supplied as standard.



H60XFA

Table 3.16: 3P, Non-Fusible, 600 Vac, 250 Vdc Maximum, Short Circuit Rating 10 kA AIR

Amperes	Enclosed Molded Case Switch ▲ ♦		Solid Neutral Assembly		Horsepower Ratings—3Ø		
	Cat. No.	\$ Price	Cat. No.	\$ Price	240 Vac	480 Vac	600 Vac■
60	H60XFA	2571.00	100SNA	143.00	15	30	50
60	H60XFA1212	2886.00	100SNA	143.00	15	30	50
100	H100XFA	3045.00	100SNA	143.00	30	60	75
100	H100XFA1212	3287.00	100SNA	143.00	30	60	75

▲ Std.—Using fast acting one time fuses. Max.—Using dual element time delay fuses.

■ For switching dc use two switching poles.

♦ For EI Kit information and pricing refer to page 3-11.

★ Not suitable for use as service equipment.

▼ Electrical interlock not available. For auxiliary switches, refer to page 7-4 for catalog number suffix and price adder (e.g. H60XFA1212).

△ Includes PKDB1, breather and drain kit, required for rainproof application—NEMA 7 only.



MD50 Motor Disconnect Switches

The MD50 Motor Disconnect Switch merges three key product features to provide safe, quick and reliable mating of mobile and fixed motors to power connections. The features include the UL508 "Suitable for Motor Disconnect" switch, the IEC 60309-2 pin and sleeve technology, and the mechanical interlock integrated in a rugged plastic enclosure. The mechanical interlock prevents the making or breaking under load of plug-connected equipment. The plug must be inserted before the power can be turned "ON". The plug cannot be removed until the power is turned "OFF". The combination of the MD50's UL508 listing, IEC 60309 technology, and the rugged plastic enclosure, provides a set of features for motor disconnecting not available in the existing UL98 Receptacle Switch offering. Grounding and conduit hub included.

Table 3.17: Non-Fusible▲

System	Amperes	Voltage	NEMA 4X and 12		Use with Plug		Horse Power Rating	Phase	Wire Size (Cu)
			Cat No.	\$ Price	Cat. No.	\$ Price			
2-Pole 3-Wire	30	125	MD330MI4	1236.00	ME330P4W	214.00	2	1	12-8
		250	MD330MI6	1249.00	ME330P6W	214.00	5	1	12-8
3-Pole 4-Wire	20	250	MD360MI6	1638.00	ME360P6W	352.00	10	1	6-2
		480	MD420MI9	1181.00	ME420P9W	162.00	7.5	3	12-8
	30	250	MD420MI7	1181.00	ME420P7W	162.00	15	3	12-8
		480	MD430MI9	1143.00	ME430P9W	236.00	10	3	12-8
		480	MD430MI7	1143.00	ME430P7W	236.00	20	3	12-8
	60	600	MD430MI5	1335.00	ME430P5W	236.00	20	3	12-8
		250	MD460MI9	1561.00	ME460P9W	344.00	20	3	6-2
		480	MD460MI7	1561.00	ME460P7W	344.00	40	3	6-2
		600	MD460MI5	1961.00	ME460P5W	344.00	50	3	6-2
	100	125/250	MD4100MI12	1773.00	ME4100P12W	465.00	125 V 5, 250 V 15	1	6-1/0
		240	MD4100MI9	2123.00	ME4100P9W	465.00	25	3	6-1/0
		480	MD4100MI7	1911.00	ME4100P7W	465.00	50	3	6-1/0
600		MD4100MI5	2123.00	ME4100P5W	465.00	50	3	6-1/0	
4-Pole 5-Wire	30	Y120/208	MD530MI9	1233.00	ME530P9W	292.00	7.5	3	12-8
		Y277/480	MD530MI7	1331.00	ME530P7W	292.00	20	3	12-8
		Y347/600	MD530MI5	1331.00	ME530P5W	292.00	20	3	12-8
	60	Y120/208	MD560MI9	1627.00	ME560P9W	409.00	20	3	6-2
		Y277/480	MD560MI7	1709.00	ME560P7W	409.00	40	3	6-2
		Y347/600	MD560MI5	1953.00	ME560P5W	409.00	50	3	6-2
	100	Y120/208	MD5100MI9	2123.00	ME5100P9W	560.00	25	3	6-1/0
		Y277/480	MD5100MI7	2123.00	ME5100P7W	560.00	50	3	6-1/0
		Y347/600	MD5100MI5	2123.00	ME5100P5W	560.00	50	3	6-1/0

▲ Suitable for use on a circuit capable of delivering not more than 10,000 RMS symmetrical amperes at the voltage rating of the receptacle.

NOTE: Auxiliary Contacts ordering information:

20 and 30 A non-fusible—ME2030AUX
60 and 100 A non-fusible—ME80AUX

Table 3.18: Fusible (Type J Fuses Only) ■◆

System	Amperes	Voltage	NEMA 4X and 12		Use with Plug		Horse Power Rating	Horse Power Rating Max.	Phase	Wire Size (Cu)
			Cat. No.	\$ Price	Cat. No.	\$ Price				
3-Pole 4-Wire	30	250	MD430MIF9	1631.00	ME430P9W	236.00	3	7.5	3	18-8
		480	MD430MIF7	2053.00	ME430P7W	236.00	5	15	3	18-8
		600	MD430MIF5	1794.00	ME430P5W	236.00	7.5	20	3	18-8
	60	250	MD460MIF9	2013.00	ME460P9W	344.00	7.5	15	3	14-4
		480	MD460MIF7	2129.00	ME460P7W	344.00	15	30	3	14-4
		600	MD460MIF5	2123.00	ME460P5W	344.00	15	30	3	14-4

■ Suitable for use on a circuit capable of delivering not more than 100,000 RMS symmetrical amperes at the voltage rating of the receptacle.

◆ UL98 Listed.

NOTE: Auxiliary Contacts ordering information:

30 A fusible—ME30FDAUX
60 A fusible—ME60FDAUX

Dimensions

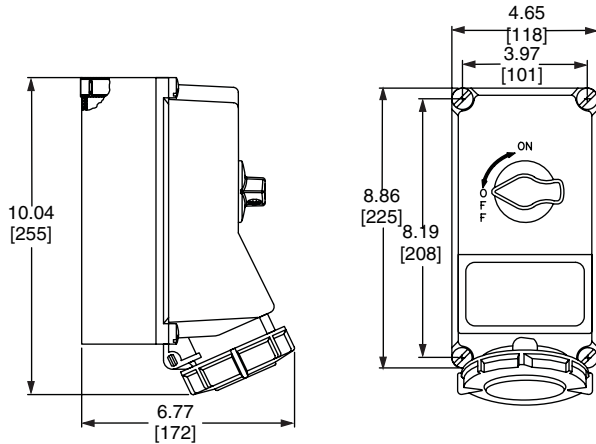

20 or 30 A Non-Fusible

- MD420MI7
- MD420MI9
- MD530MI5
- MD530MI7
- MD530MI9

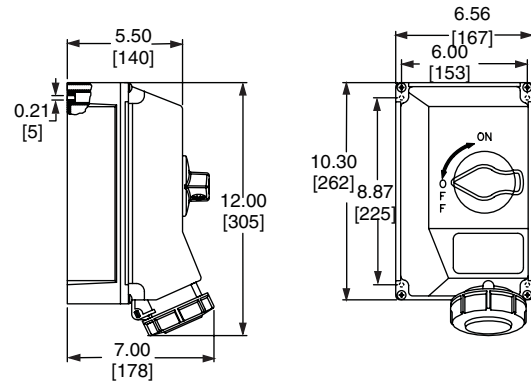

30 A Non-Fusible

- MD330MI4
- MD330MI6
- MD430MI5
- MD430MI7
- MD430MI9

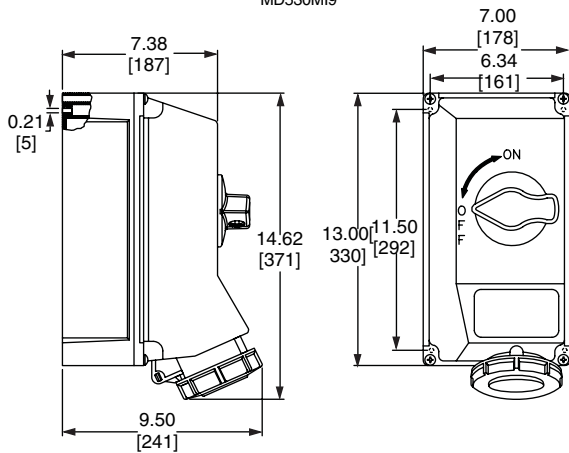

60 A Non-Fusible

- MD360MI6
- MD460MI5
- MD460MI7
- MD460MI9
- MD560MI5
- MD560MI7
- MD560MI9

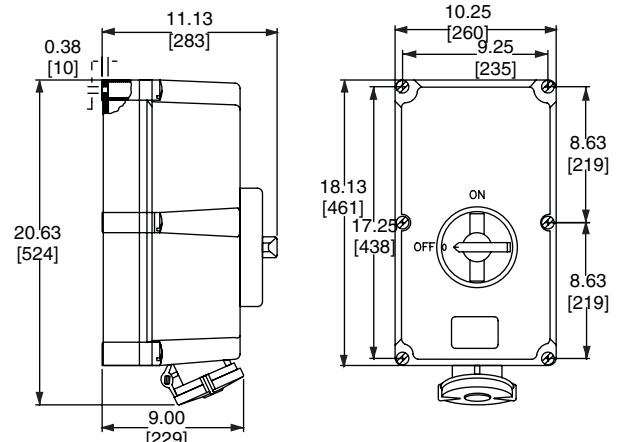

100 A Non-Fusible

- MD4100MI5
- MD4100MI7
- MD4100MI9
- MD4100MI12
- MD5100MI5
- MD5100MI7
- MD5100MI9

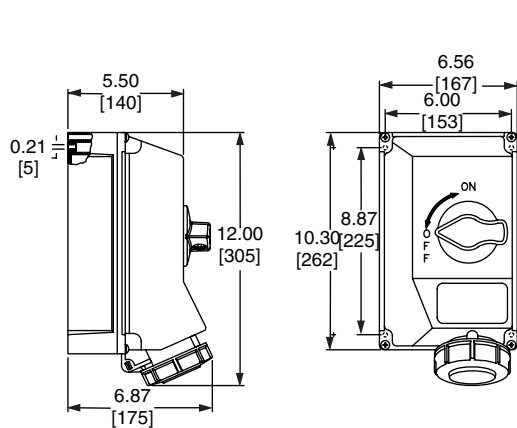

30 A Fusible

- MD430MIF5
- MD430MIF7
- MD430MIF9

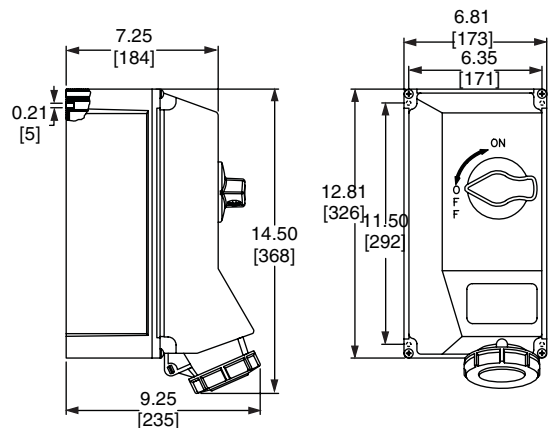

60 A Fusible

- MD460MIF5
- MD460MIF7
- MD460MIF9

Interlocked Receptacle Switches

Interlocked Receptacle Switches are furnished with a factory-installed three-phase four-wire Appleton Powertite®, Crouse-Hinds Style 2 Arktite®, or Hubbellock® receptacle. The fourth wire is connected to the switch equipment grounding terminal and is not a neutral termination. Interlocking linkage between the receptacle and switch mechanism prevents insertion or removal of the plug while the switch is in the "ON" position or insertion of any plug other than specified. Grounding lugs are included.

Appleton Powertite Receptacle

- Devices are UL Listed and CSA Certified, suitable for use as service equipment.
- Receptacles are epoxy powder coated over copper-free cast aluminum and NEMA 3, 3R, 4, 4X and 12 rated. Appleton receptacles are UL Classified for use with the Crouse-Hinds plugs listed below.
- Short circuit rating: 10 kA when used in conjunction with Class H or K fuses; 200 kA when used in conjunction with Class R or J fuses.



H362AWA
Interlocked Receptacle
Switch with Appleton
Powertite Receptacle

Amperes	NEMA 1		NEMA 3, 3R, 4, 4X, 5, 12 304 Stainless Steel Enclosure		NEMA 12, 3R		Use with Plug ▲		Horsepower Ratings-3Ø■					
	Cat. No.	\$ Price	Cat. No.	\$ Price	Cat. No.	\$ Price	Cat. No.	\$ Price	480 Vac		600 Vac		250 Vdc♦	
									Std.	Max.	Std.	Max.	Std.	Max.
Fusible—3P, 600 Vac, 250 Vdc														
30	H361WA	2076.00	H361DSWA	4401.00	H361AWA	2289.00	ACP3034BC	1235.00	5	15	7-1/2	20	5	—
60	H362WA	2412.00	H362DSWA	4668.00	H362AWA	2508.00	ACP6034BC	1295.00	15	30	15	50	10	—
100	H363WA	3689.00	H363DSWA	8468.00	H363AWA	3758.00	ACP1034CD	1928.00	25	60	30	75	20	—
Non-Fusible—3P, 600 Vac, 250 Vdc														
30	HU361WA	1893.00	HU361DSWA	4001.00	HU361AWA	2076.00	ACP3034BC	1235.00	—	20	—	30	—	5
60	HU362WA	2306.00	HU362DSWA	4412.00	HU362AWA	2357.00	ACP6034BC	1295.00	—	50	—	60	—	10
100	HU363WA	3153.00	HU363DSWA	8010.00	HU363AWA	3347.00	ACP1034CD	1928.00	—	75	—	100	—	20

- ▲ Receptacle UL Listed for use with "Appleton ACP or CPH" plugs; UL Classified for use with Crouse-Hinds "APJ" Arktite plugs listed on this page.
- Std.—Using fast acting one time fuses. Max.—Using dual element time delay fuses.
- ♦ For switching dc, use two switching poles.

Crouse-Hinds Arktite Receptacle

- UL Listed, suitable for use as service equipment.
- Short circuit ratings: 10 kA when used in conjunction with Class H or K fuses; 200 kA when used in conjunction with Class R or J fuses.

Table 3.19:

Amperes	NEMA 1		NEMA 3, 3R, 4, 4X, 5, 12 304 Stainless Steel Enclosure		NEMA 12, 3R		Use with Plug		Horsepower Ratings-3Ø★				
	Cat. No.	\$ Price	Cat. No.	\$ Price	Cat. No.	\$ Price	Cat. No.	\$ Price	480 Vac		600 Vac		
									Std.	Max.	Std.	Max.	
Fusible—3P, 600 Vac Maximum													
30	H361WC	2139.00	H361DSWC	6377.00	H361AWC	2355.00	APJ3485	1235.00	5	15	7-1/2	20	
60	H362WC	2751.00	H362DSWC	7749.00	H362AWC	2846.00	APJ6485	1295.00	15	30	15	50	
100	H363WC	6005.00	H363DSWC	14826.00	H363AWC	6087.00	APJ10487	1928.00	—	60	—	75	
Non-Fusible—3P, 600 Vac Maximum													
30	HU361WC	1952.00	HU361DSWC	5888.00	HU361AWC	2136.00	APJ3485	1235.00	—	20	—	30	
60	HU362WC	2634.00	HU362DSWC	7374.00	HU362AWC	2678.00	APJ6485	1295.00	—	50	—	60	
100	HU363WC	5249.00	HU363DSWC	14025.00	HU363AWC	5444.00	APJ10487	1928.00	—	60	—	100	

- ★ Std.—Using fast acting one time fuses. Max.—Using dual element time delay fuses.

Hubbellock Receptacle

- UL Listed, suitable for use as service equipment.
- Short circuit rating: 10 kA.

Note: The Hubbellock receptacle switch utilizes the Square D interlocked plug SD12781 available only from Square D.

Table 3.20:

Amperes	NEMA 1		NEMA 12		Use with Plug		Horsepower Ratings-3Ø▼			
	Cat. No.	\$ Price	Cat. No.	\$ Price	Cat. No.	\$ Price	480 Vac		600 Vac	
							Std.	Max.	Std.	Max.
Fusible—3P, 600 Vac Maximum										
60	H362WH	2351.00	H362AWH	2459.00	SD12781△	609.00	15	30	15	50
Non-Fusible—3P, 600 Vac Maximum										
60	HU362WH	2237.00	HU362AWH	2310.00	SD12781△	609.00	—	50	—	60

- ▼ Std.—Using fast acting one time fuses. Max.—Using dual element time delay fuses.
- △ Hubbell plug is furnished with a Kellems grip for 1-1/2 in. to 1-21/64 in. cable diameter.

Accessories pages 3-11 through 3-13.



H362AWC
Interlocked Receptacle
Switch with Crouse-Hinds
Arktite Receptacle



H362AWH
Interlocked Receptacle
Switch with Hubbell®
Hubbellock Receptacle

3 SAFETY SWITCHES



Rainproof Bolt-On Hubs—for use on NEMA 3R Enclosure

Conduit Size	3/4	1	1-1/4	1-1/2	2	2-1/2	3	3-1/2	4	Closing Cap
Hub Cat. No.	B075	B100	B125	B150	B200	B250	B300	B350	B400	BCAP
\$ Price Each (DE1A)	33.30	33.30	33.30	33.30	61.00	102.00	186.00	300.00	368.00	3.80

Note: NEMA 3R rainproof enclosures with Cat. No. ending in RB have a bolt-on closing cap factory-installed. Order bolt-on hubs separately from table above. For more details see page 1-13. Hubs through size 2-1/2", can be directly installed on RB devices. Devices requiring three-inch or larger hubs must have holes cut in the field. Gaskets are provided on three-inch and larger hubs.

Note: All hubs are UL Listed for indoor and rainproof applications and suitable for use with conduit having ANSI standard taper pipe thread.

Watertight Hubs—for use on NEMA 4, 4X and 5 Stainless Steel and NEMA 12 Enclosures

Conduit Trade Size	1/2	3/4	1	1-1/4	1-1/2	2	2-1/2	3	3-1/2	4
Standard-Zinc Hub Cat. No.	H050	H075	H100	H125	H150	H200	H250	H300	H350	H400
Zinc \$ Price Each	31.10	45.00	47.10	54.00	83.00	120.00	138.00	177.00	282.00	381.00
Chrome Plated Hub Cat. No.	H050CP	H075CP	H100CP	H125CP	H150CP	H200CP	—	—	—	—
Chrome Plated \$ Price Each	40.70	56.00	64.00	67.00	96.00	137.00	—	—	—	—

Electrical Interlock Kits

Electrical interlocks for heavy duty 30–1200 A safety switches are available factory-installed or in kit form for field installation. Each kit contains instructions for proper field mounting. A pivot arm operates from switch mechanism, breaking the control circuit before the main switch blades break. Switches with electrical interlocks installed are UL Listed. For factory-installed electrical interlocks add EI (for one contact) or EI2 (for two contacts) suffix to catalog number. See Supplemental Digest page 2-4 for electrical interlock contact ratings.

Table 3.21: Electrical Interlock Kit ▲

Switch Rating (A)	Series Number (See pages 3-14, 3-15)	Electrical Interlock Kit Cat. No. ■	\$ Price	Factory-Installed \$ Price
30	F1, F5–F7	EIK031 ◆ ★	218.00	359.00
		EIK032 ◆ ★		
60	F3	EIK1	311.00	452.00
		EIK2		
100–200	F1-F3 F5–F7 (600 V)	EIK1	311.00	452.00
		EIK2		
400–1200	F4 F5–F6 (240 V)	EIK031 ▼	218.00	359.00
		EIK032 ▼		
100–200	F2–F7	EIK1	311.00	452.00
		EIK2		
400–1200	E1–E4	EIK40601	533.00	674.00
		EIK40602		

- ▲ See page 3-7 for electrical interlocks on NEMA 4X fiberglass reinforced polyester and Krydon™.
- Electrical interlock kit catalog numbers with 1 suffix indicates one normally open and one normally closed contact; 2 indicates two normally open and two normally closed contacts. Kits are UL Listed.
- ◆ HU461AWK uses EK3061 or EK3062.
- ★ The following Series F5–F7 devices use EIK-1, 2: H3612, H3612A, H3612AWK, H3612RB, H461, H461DS, H461AWK, HU461, HU461DS, HU661DS, HU661AWK, H361AWA, H361AWC, HU361AWA and HU361AWC.
- ▼ H362WA, HU362WA, H362WC, H362AWA, HU362AWA, H362AWC, HU362AWC, and H2212AWK use EIK1 or EIK2 electric interlock.
- △ Single-pole single-throw interlock kits are rated 1/2 hp @ 110 and 220 Vac.

Class R Fuse Kits

When installed, this kit rejects all but Class R fuses. Kits are available for field installation. For factory installation, add “CLR” suffix to catalog number.

Table 3.22: Class R Fuse Kits—240 V (one kit per 3P switch)

Switch Rating (A)	Series Number (See pages 3-14, 3-15)	Class R Fuse Kit Cat. No.	\$ Price	Factory-Installed \$ Price
30	F5–F7	RFK03L □	25.50	195.00
60	F1, F2, F3	RFK06	25.50	195.00
60	F4–F7	RFK03H	25.50	195.00
100	F2–F7	RFK10	47.70	231.00
200	F5–F6	HRK1020	47.70	231.00
400–600	E	HRK4060	111.00	360.00

□ H221-2AWK uses RFK06 Class R fuse kit.

Table 3.23: Class R Fuse Kits—600 V (one kit per 3P switch)

Switch Rating (A)	Series Number (See pages 3-14, 3-15)	Class R Fuse Kit Cat. No.	\$ Price	Factory-Installed \$ Price
30 ◆	F1, F5–F7	RFK03H ★	38.25	293.00
30 ◆	F3	RFK06	38.25	293.00
60 ◆	F1–F7	RFK06H ★	38.25	293.00

Table 3.23: Class R Fuse Kits—600 V (one kit per 3P switch)

Switch Rating (A)	Series Number (See pages 3-14, 3-15)	Class R Fuse Kit Cat. No.	\$ Price	Factory-Installed \$ Price
100 ◆	F2–F7	RFK10	47.70	231.00
200	F5–F6	HRK1020	47.70	231.00
400–600	E2–E4	HRK4060	111.00	360.00

◆ See page 3-7 for Class R Fuse Kits in NEMA 4X Fiberglass Reinforced Polyester and Krydon switches.

★ The following Series F5–F7 devices use RFK06: H3612, H3612A, H3612AWK, H3612RB, H461, H461DS, H461AWK, H361AWA and H361AWC.

Internal Barrier Kits



Internal Barrier Kits provide an additional barrier that helps prevent accidental contact with live parts. Field-installed transparent barriers do not restrict visual inspection of the switch. Barriers provide IEC529 IP2X “finger safe” protection when door of enclosed disconnect switch is open. Convenient door allows use of test probes without accessing fuses and replacement of fuses without removing barrier. Barrier can also be used with the skirt kit to enclose a panel mounted Type 9422 disconnect.

Cat. No.	Description	Safety Switch Application (F Series Only)	9422 Type T Disconnect Application	\$ Price
SS03	Interior Barrier for 30 A Safety Switch▽	240 / 600 Vac – 30 A	NA	150.
		240 Vac – 60 A		
SS06	Interior Barrier for 60 A Safety Switch, 30 or 60 A 9422 Switch	600 Vac – 60 A	600 Vac – 30 A	165.
			600 Vac – 60 A	
SS10	Interior Barrier for 100 A Safety Switch or 100 A 9422 Switch	240 / 600 Vac – 100 A	600 Vac – 100 A	195.
SS20	Interior Barrier for 200 A Safety Switch	240 / 600 Vac – 200 A	NA	225.
SS0306SK	Skirt Kit to Enclose 30 or 60 A 9422 Switch (requires SS06)	NA	600 Vac – 30 A	225.
			600 Vac – 60 A	
SS10SK	Skirt Kit to Enclose 100 A 9422 Switch (requires SS10)	NA	600 Vac – 100 A	255.

▽ Requires arc shield on 240 V switches be changed to 600 V arc suppressor.

Fuse Puller Kits

Kit consists of three fuse pullers as required for a 3-pole fusible 240 V or 600 V heavy duty switch. Kits can be installed in switches manufactured after February, 1980. Fuse pullers supplied as standard equipment on NEMA 12, 12K, NEMA 4, 4X, 5 stainless steel, NEMA 4X fiberglass reinforced polyester and KRYDON switches through 100 A.

Switch Rating (A)	Series Number	Fuse Puller Kit Cat. No.	\$ Price
30	F1, F5–F7 F3	FPK03 ○	30.00
30		FPK0610	42.60
60	F1, F2, F3, F5–F7 (600 V) F4 ★, F5–F7 (240 V)	FPK0610	42.60
60 ★		FPK03 ★	30.00
100	F2–F7	FPK0610	42.60

○ 30 A 4- and 6-pole, H361-2 and H361-2RB Series F5 use FPK0610.

★ H362WA, H362WC, H362AWA, H362AWC, H362WH and H362AWH use FPK0610 fuse puller kit.

Neutral Assemblies—Field-Installed Neutral Assemblies for Fusible and Non-Fusible 240 and 600 Volt Safety Switches

Switch Rating (A)	Series Number (See pages 3-14, 3-15)	Standard Neutral Kit Cat. No.	Terminal Data AWG/kcmil	\$ Price	Optional Copper Only Neutral Kit Cat. No.	Terminal Data AWG/kcmil	\$ Price
30	F1, F5-F6	SN03▲	(3) 2 Max. Al/Cu	83.00	SN03C▲	(3) 6 Max. Cu	102.00
60	F1-F3, F5-F6 (600 V)	SN0610	(2) 1/0 Max. Al/Cu (2) 6 Max. Al/Cu	107.00	SN0610C	(2) 1/0 Max. Cu (2) 6 Max. Cu	114.00
	F4, F5-F6 (240 V)	SN03▲	(3) 2 Max. Al/Cu	83.00	SN03C▲	(3) 6 Max. Cu	102.00
100	F2-F6	SN0610	(2) 1/0 Max. Al/Cu (2) 6 Max. Al/Cu	107.00	SN0610C	(2) 1/0 Max. Cu (2) 6 Max. Cu	114.00
200■	F5-F6	SN20A	(2) 250 Max. Al/Cu (1) 1/0 Max. Al/Cu	200.00	SN20C	(2) 250 Max. Cu (1) 1/0 Max. Cu	246.00
400 and 600	E1-E4	H600SN	(4) 750 Max. Al/Cu (1) 300 Max. Al/Cu	327.00	H600SNC	(2) 600 Max. Cu (2) 350 Max. Cu (1) 250 Max. Cu	452.00
800	E2-E4	H800SNE4	(6) 750 Max. Al/Cu (2) 350 Max. Al/Cu	753.00	—	—	—
1200	E2-E4	H1200SNE4	(8) 750 Max. Al/Cu (2) 350 Max. Al/Cu	1034.00	—	—	—

Note: Neutrals cannot be installed in 4P, 6P, or 200 A NEMA 4X fiberglass reinforced polyester safety switches.

- ▲ The following Series F5-F6 devices use SN0610(C): H-361-2, H-361-2RB, H-361-2A and H-361-2AWK.
- For 200% neutral, order (2) neutral kits and (1) SN20NI neutral jumper kit. (2) 350 Max. Al/Cu.

Equipment Grounding Kits

Equipment grounding kits are field-installed and UL Listed in 30-1200 A heavy duty switches. For factory installation of equipment grounding kit, add suffix GL to standard Cat. No. (Example: H361GL). Price = Switch + Kit Price.

NOTE: Kits are factory-installed standard in 30-200 A series F NEMA 4-4X-5 (stainless) and 12, and in all NEMA 30-200 A Series F 4-6P switches.

Equipment Grounding Kits—Field- or Factory-Installed Equipment Grounding Kits—240 and 600 V

Switch Rating (A)	Series Number (See pages 3-14, 3-15)	Standard Cat. No.	Terminal Data AWG/kcmil	\$ Price	Optional Copper Only Cat. No.	Terminal Data AWG/kcmil	\$ Price
30	F1, F5-F7	GTK03◆	(2) 12 Cu or (2) 10 Al or (1) 4 Max. Al/Cu	11.40	GTK03C◆	(1) 6 Max. Cu	13.40
60★	F1-F3★, F5-F7 (600 V)	GTK0610★	(2) 2/0 Max. Al/Cu	18.90	GTK0610C★	(2) 4 Max. Cu	22.70
60	F4, F5-F6 (240 V)	GTK03	(2) 12 Cu or (2) 10 Al or (1) 4 Max. Al/Cu	11.40	GTK03C	(1) 6 Max. Cu	13.40
100	F2-F7	GTK0610	(2) 2/0 Max. Al/Cu	18.90	GTK0610C	(2) 4 Max. Cu	22.70
200	F5-F7	PKOGTA2	(2) 2/0 Max. Al/Cu	55.00	PKOGTC2	(2) 4 Max. Cu	58.00
400 and 600	E2-E4	PKOGTA2▼ (2 Required)	(2) 2/0 Max. Al/Cu	55.00	PKOGTC3	(4) 1/0 Max. Cu	107.00△
800	E2-E4	PKOGTA7	(4) 350 Max. Al/Cu	198.00△	—	—	—
1200	E2-E4	PKOGTA8	(8) 350 Max. Al/Cu	203.00△	—	—	—

- ◆ The following Series F5-F6 devices use GTK0610(C): H-361-2 and H-361-2RB.
- ★ 4- and 6-pole 30 A F Series.
- ▼ Two required if grounding conductors are run in parallel.
- △ PE1A Discount Schedule

Table 3.24: Square D Gray Paint

Description	Cat. No.	\$ Price
16 oz. Aerosol Paint Can, Square D Gray Paint	PK49SP	39.00 ea.

Note: Shipped in quantities of 6.

Special Paint

UL Listed heavy duty switches are available painted with special safety colors. Special colors available include: safety red, safety orange, safety yellow, safety green, safety blue, safety purple, black and white.

All colors comply with OSHA Standard 1910.144 and ANSI Specification Z535.1 for marking physical hazards.

A minimum quantity of 10 is required. To order, add suffix SP to standard Cat. No. Specify color on order.

Price Adder Each Switch

Quantity	\$ Price							
	30 A	60 A	100 A	200 A	400 A	600 A	800 A	1200 A
10	242.00	278.00	434.00	479.00	1137.00	2801.00	3501.00	4376.00

Lock-Off Guard Kits

Available factory- or field-installed the lock-off guard works by covering the lockout/tagout opening whenever the switch is in the ON position. This prevents a padlock from being inadvertently inserted into the switch lockplate. The device is designed to help prevent accidental misapplication of a lockout device. These kits are marked cURus (UL Component Recognized) for field or factory installation.

Switch Rating (A)	Kit Cat. No.	Field-Installed \$ Price	Factory-Installed \$ Price
30 A	LOGK1	44.30	146.00
60 A 240 V			
60 A 600 V	LOGK2	45.00	177.00
100 and 200 A			

□ For factory installation, add suffix "LOG" to the switch catalog number.



Key Interlock Systems



Factory-installed only on heavy duty safety switches and double throw safety switches. Interlocks are used to prevent the authorized operator from making an unauthorized operation. Not available on hazardous location devices (NEMA 7/9) or fiberglass reinforced polyester (NEMA 4X). The key interlock system is a simple and easy method of applying individual key interlock units and assemblies to the above equipment so as to require operation in a predetermined sequence. UL Listed.

Quoting:

Contact Schneider Electric for catalog number, availability, and pricing prior to quoting a job.

Detailed information is required before an order can be processed. Please see Supplemental Digest page 2.3 for further information.

Use these suffixes on switch catalog numbers:

- KI = 1 lock per switch
- KI2 = 1 lock with 2 cylinders (2 keys) per switch
- KIKI = 2 separate locks per switch

Table 3.25: Price Adder Per Lock ▲

Switch Type	\$ Price
30-1200 A Heavy Duty	2055.00
30-600 A Double Throw	1988.00

▲ Prices do not apply when more than three devices are interlocked, as these schemes normally require more than one key assembly per device.

Lock-On Provisions

Lock-off provisions are standard on all heavy duty safety switches. Provision for one 3/8-inch hasp padlock is available factory-installed on NEMA 1, 3R, 4-4X-5 stainless steel and 12 switches. This modification will allow the switch to be locked in the "ON" position. UL Listed.

Table 3.26: Price Adder Per Each Switch

Safety Switch Rating	\$ Price
30-1200 A	155.00

To order, add suffix SPLO to standard catalog number. Example: H364-SPLO

Cover Viewing Window



Optional cover viewing window is positioned over the blades to allow visual verification of "ON-OFF" status. Available on 30 through 1200 A heavy duty switches, all NEMA Types. (Not available on NEMA 4X fiberglass reinforced polyester, Krydon® enclosures, or NEMA 7 and 9 devices.)

Factory-installed only: add "VW" suffix to the Cat. No. See table below for price adder.

Table 3.27: Price Adder Per Switch—UL Listed

Amperes	2- and 3-Pole	4- and 6-Pole
30-200 A	38.00	75.00
400-1200 A	2297.00	—

Switch Lubricant

Field maintenance lubricant is available for servicing blade and jaw components in switches 600 V and below. Catalog number **SWLUB** (list price \$24.14) consists of one tube of BG20 High Performance Synthetic Grease manufactured by Dow Corning®, a material safety data sheet, and re-lubrication information. SWLUB is available in warehouse stock, shipped individually on in multiples of 12 units per carton.

BG20 grease by Dow Corning is a high-performance synthetic grease which is biodegradable and has an operating temperature range from -50° F (-45°C) to 360° F (180°C). This temperature range exceeds normal operating conditions for switches as defined by NEMA.

This grease has undergone extensive testing as a lubricant for maintaining blade and jaw areas in switches. Do not substitute any other lubricants.

Copper Only Lug Kits

Heavy duty safety switches are supplied standard with Al lugs, which accept both Cu and Al wires. For field installation of copper-only lug kits, order kits below. For factory installation of copper only lugs, add suffix SLC to standard Cat. No. **Note:** NEMA 12, 12K and stainless steel switches with factory-installed lugs bear the UL Marine Listed manifest for use on vessels over 65 feet long. NEMA 12, 12K and stainless steel switches using field-installed copper only lug kits are UL Marine Listed, but do not bear the marine manifest.

Table 3.28: Kits – Wire size (page 3-15)

Switch (A)	Lug Kit Cat. No. ■	Kit \$ Price	Factory-Installed Adder per Switch
30	CL0306F	69.00	224.00
60	CL0306F	69.00	224.00
100	CL10F	159.00	431.00
200	CL20F	264.00	717.00
400	CL40F	549.00	1490.00
600	CL60F	893.00	2426.00
800	—	—	—
1200	—	—	—

■ One kit includes all phase line/load lugs for a 3-pole switch.

Double Lug Kits

200 A heavy duty F-series switches are supplied standard with lugs listed on page 3-14 (one wire per phase). For lugs that accept two wires per phase and neutral, order the following kit:

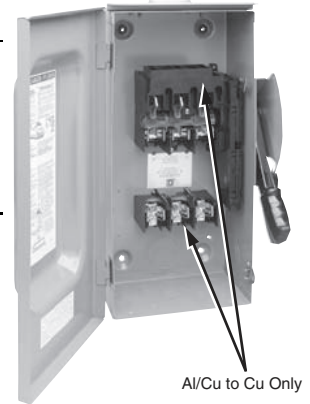

Al/Cu to Cu Only

Switch (A)	Lug Kit ♦ Cat. No.	Kit \$ Price★	Lug wire range per phase and neutral AWG/kcmil	Switch wire range per phase and neutral AWG/kcmil
200	AL20DTF	159.00	(2) 6-300 Cu/Al	(2) 6-250 Cu/Al

♦ Not UL Listed.

★ Kit contains 3 lugs. For double lugs for line and load, order 2 kits.

Table 3.29: 800 and 1200 A Compression Lug Kits—Field-Installed (See page 3-14 for 100-600 A Switches)

Series E4 800 and 1200 A safety switches are equipped as standard with mechanical lugs. Alternate compression lug kits are available for field installation and are UL Listed. Each kit consists of VCEL07512H1 Versa-Crimp® Compression Lugs and lug landing connectors capable of converting line and load side of one switch pole or neutral.

Order one field-installed kit per pole or neutral per table below. Example: Three-pole three-wire requires three kits; three-pole, four-wire requires four kits.

Switch Amperes	Lug Kit Cat. No.	\$ Price Per Pole or Neutral
800	H8LKE2	893.00
1200	H12LKE2	1109.00

Note: For terminal lug data, refer to table below.

Table 3.30: Factory-Installed

Series E4 800 and 1200 A safety switches are available with factory-installed VCEL-075-12H1 Versa-Crimp compression lug kits (above). For factory installation, add suffix LK to standard Cat. No. (Example: H367LK) and use price adder from table below based on system type.

Switch Amperes	System	Factory-Installed \$ Price Adder Per Switch
800	2 Wire	2106.00
	3 Wire	2972.00
	4 Wire	3839.00
1200	2 Wire	2591.00
	3 Wire	3696.00
	4 Wire	4806.00

Note: For terminal Lug data refer to table below.

Table 3.31: Terminal Lug Data—800 and 1200 A Compression Lugs

Switch Amperes	Conductors Per Phase	Compression Lug (VCEL-075-12H1) Wire Range
800	(3) Line and (3) Load	500-750 kcmil (Al) or 500 kcmil (Cu)
	(4) Line and (4) Load	500-750 kcmil (Al) or 500 kcmil (Cu)

Table 3.32: Terminal Lug Data (NEMA 1, 3R, 4, 4X, 5, 7, 9, 12)▲

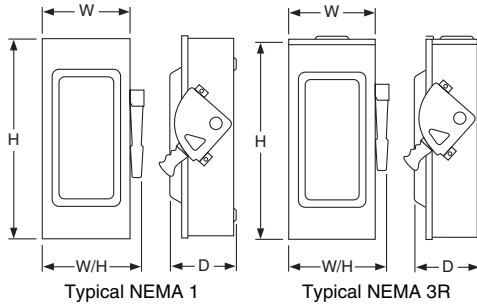

Rating (A)	Conductors Per Phase and Neutral	Wire Range Wire Bending Space Per NEC Table 312.6 AWG/kcmil	Lug Wire Range AWG/kcmil	Optional Versa-Crimp® Compression Lug Field-Installed■
30◆	1	12-6 (Al) or 14-6 (Cu)	12-2 (Al) or 14-2 (Cu)	—
	2	14-10 (Cu) solid or 14-10 (Cu) stranded		
60★	1	14-3 (Al) or 14-3 (Cu)	12-2 (Al) or 14-2 (Cu)	—
100	1	12-1/0 (Al) or 14-1/0 (Cu)	12-1/0 (Al) or 14-1/0 (Cu)	VCLE02114S1
200▼	1	6-250 (Al/Cu)	6-300 (Al/Cu)	VCLE030516H1
				VCLE07512H1 or VCLE030516H1□ and VCLE05012H1
400	1 or 2	1/0-750 (Al/Cu)△ or 1/0-300 (Al/Cu)	1/0-750 (Al/Cu) and 1/0-300 (Al/Cu)	VCLE05012H1
600	2	3/0-500 (Al/Cu)	3/0-500 (Al/Cu)	VCLE05012H1
800	3	3/0-750 (Al/Cu)	3/0-750 (Al/Cu)	H8LKE2◇
1200	4	3/0-750 (Al/Cu)	3/0-750 (Al/Cu)	H12LKE2 ◇

- ▲ 30-100 A switches suitable for 60°C or 75°C conductors. 200-1200 A switches suitable for 75°C conductors.
- For NEMA 1 and 3R only.
- ◆ HU461AWK— 14-6 AWG (Cu).
- ★ H60XFA— 14-6 AWG (Cu).
- ▼ H225XKA— 4 AWG-300 kcmil (Cu).
- △ Max. wire range is (1) 600 kcmil or (2) 300 kcmil Al/Cu on NEMA 4X Stainless and NEMA 12.
- Order two PK516KN mounting kits when installing VCLE030516H1 lugs. Only one kit is required on 2-Pole switches.
- ◇ See page 3-13, 800 and 1200 A compression lug kits for additional information.

Cat. No.	Approximate Dimensions								Cat. No.	Approximate Dimensions									
	Series	H		W		D		W/H		Series	H		W		D		W/H		
		in.	mm	in.	mm	in.	mm	in.			mm	in.	mm	in.	mm	in.	mm	in.	mm
H221N	F5	14.60	371	6.50	165	4.88	124	7.55	192	H364, N	F5	29.00	737	17.13	435	8.25	210	18.50	470
H221NRB	F5	14.88	378	6.63	168	4.88	124	7.55	192	H364RB, NRB	F5	29.25	743	17.25	438	8.50	216	18.63	473
H222N	F5	14.60	371	6.50	165	4.88	124	7.55	192	H365, N	E4	50.25	1276	27.63	702	10.13	257	27.63	702
H222NRB	F5	14.88	378	6.63	168	4.88	124	7.55	192	H365R, NR	E5	50.31	1278	27.76	705	9.53	242	27.88	708
H223N	F5	21.25	540	8.50	216	6.38	162	10.50	267	H366, N	E4	50.25	1276	27.63	702	10.13	257	27.63	702
H223NRB	F5	21.25	540	8.50	216	6.38	162	10.50	267	H366NR, R	E5	50.31	1278	27.76	705	9.53	242	27.88	708
H224N	F5	29.00	737	17.13	435	8.25	210	18.50	470	H367, N	E4	69.13	1756	36.62	930	17.75	451	36.62	930
H224NRB	F5	29.25	743	17.25	438	8.50	216	18.63	473	H367NR, R	E4	69.13	1756	36.62	930	17.75	451	36.62	930
H225, N	E4	50.25	1276	27.63	702	10.13	257	27.63	702	H368, N	E4	69.13	1756	36.62	930	17.75	451	36.62	930
H225NR, R	E5	50.31	1278	27.76	705	9.53	242	27.88	708	H368NR, R	E4	69.13	1756	36.62	930	17.75	451	36.62	930
H226, N	E4	50.25	1276	27.63	702	10.13	257	27.63	702	H461	F5	20.50	521	14.75	375	6.85	174	16.13	410
H226NR, R	E5	50.31	1278	27.76	705	9.53	242	27.88	708	H462	F5	20.50	521	14.75	375	6.85	174	16.13	410
H227, N	E4	69.13	1756	36.62	930	17.75	451	36.62	930	H463	F5	20.50	521	14.75	375	6.85	174	16.13	410
H227NR, R	E4	69.13	1756	36.62	930	17.75	451	36.62	930	H464	F5	29.00	737	23.25	591	8.75	222	24.88	632
H228, N	E4	69.13	1756	36.62	930	17.75	451	36.62	930	H465	E4	50.25	1276	33.88	861	10.13	257	33.88	861
H228NR, R	E4	69.13	1756	36.62	930	17.75	451	36.62	930	H466	E4	50.25	1276	33.88	861	10.13	257	33.88	861
H265, N	E4	50.25	1276	27.63	702	10.13	257	27.63	702	HU265	E4	50.25	1276	27.63	702	10.13	257	27.63	702
H265R	E5	50.31	1278	27.76	705	9.53	242	27.88	708	HU265R	E5	50.31	1278	27.76	705	9.53	242	27.88	708
H266	E4	50.25	1276	27.63	702	10.13	257	27.63	702	HU266	E4	50.25	1276	27.63	702	10.13	257	27.63	702
H266R	E5	50.31	1278	27.76	705	9.53	242	27.88	708	HU266R	E5	50.31	1278	27.76	705	9.53	242	27.88	708
H267	E4	69.13	1756	36.62	930	17.75	451	36.62	930	HU267	E4	69.13	1756	36.62	930	17.75	451	36.62	930
H267R	E4	69.13	1756	36.62	930	17.75	451	36.62	930	HU267R	E4	69.13	1756	36.62	930	17.75	451	36.62	930
H268	E4	69.13	1756	36.62	930	17.75	451	36.62	930	HU268	E4	69.13	1756	36.62	930	17.75	451	36.62	930
H268R	E4	69.13	1756	36.62	930	17.75	451	36.62	930	HU268R	E4	69.13	1756	36.62	930	17.75	451	36.62	930
H321N	F5	14.60	371	6.50	165	4.88	124	7.55	192	HU361	F5	14.60	371	6.50	165	4.88	124	7.55	192
H321NRB	F5	14.88	378	6.63	168	4.88	124	7.55	192	HU361RB	F5	14.88	378	6.63	168	4.88	124	7.55	192
H322N	F5	14.60	371	6.50	165	4.88	124	7.55	192	HU361WA	F6	18.19	462	9.00	229	6.81	173	10.50	267
H322NRB	F5	14.88	378	6.63	168	4.88	124	7.55	192	HU361WC	F6	18.19	462	9.00	229	6.81	173	10.50	267
H323N	F5	21.25	540	8.50	216	6.38	162	10.50	267	HU362	F5	17.50	445	9.00	229	6.38	162	10.50	267
H323NRB	F5	21.25	540	8.50	216	6.38	162	10.50	267	HU362RB	F5	17.50	445	9.00	229	6.38	162	10.50	267
H324N	F5	29.00	737	17.13	435	8.25	210	18.50	470	HU362WA	F6	18.19	462	9.00	229	6.81	173	10.50	267
H324NRB	F5	29.25	743	17.25	438	8.50	216	18.63	473	HU362WC	F6	18.19	462	9.00	229	6.81	173	10.50	267
H325, N	E4	50.25	1276	27.63	702	10.13	257	27.63	702	HU362WH	F5	18.19	462	9.00	229	6.81	173	10.50	267
H325R, NR	E5	50.31	1278	27.76	705	9.53	242	27.88	708	HU363	F5	21.25	540	8.50	216	6.38	162	10.50	267
H326, N	E4	50.25	1276	27.63	702	10.13	257	27.63	702	HU363RB	F5	21.25	540	8.50	216	6.38	162	10.50	267
H326R, NR	E5	50.31	1278	27.76	705	9.53	242	27.88	708	HU363WA	F6	21.85	462	9.00	229	6.81	173	10.50	267
H327, N	E4	69.13	1756	36.62	930	17.75	451	36.62	930	HU363WC	F6	21.85	555	9.00	229	6.81	173	10.50	267
H327R, NR	E4	69.13	1756	36.62	930	17.75	451	36.62	930	HU364	F5	29.00	737	17.13	435	8.25	210	18.50	470
H328, N	E4	69.13	1756	36.62	930	17.75	451	36.62	930	HU364RB	F5	29.25	743	17.25	438	8.50	216	18.63	473
H328R, NR	E4	69.13	1756	36.62	930	17.75	451	36.62	930	HU365	E4	50.25	1276	27.63	702	10.13	257	27.63	702
H361, N	F5	14.60	371	6.50	165	4.88	124	7.55	192	HU365R	E5	50.31	1278	27.76	705	9.53	242	27.88	708
H361-2	F5	17.50	445	9.00	229	6.38	162	10.50	267	HU366	E4	50.25	1276	27.63	702	10.13	257	27.63	702
H361NRB, RB	F5	14.88	378	6.63	168	4.88	124	7.55	192	HU366R	E5	50.31	1278	27.76	705	9.53	242	27.88	708
H361WA	F6	18.19	462	9.00	229	6.81	173	10.50	267	HU367	E4	69.13	1756	36.62	930	17.75	451	36.62	930
H361WC	F6	18.19	462	9.00	229	6.81	173	10.50	267	HU367R	E4	69.13	1756	36.62	930	17.75	451	36.62	930
H362, N	F5	17.50	445	9.00	229	6.38	162	10.50	267	HU368	E4	69.13	1756	36.62	930	17.75	451	36.62	930
H362NRB, RB	F5	17.50	445	9.00	229	6.38	162	10.50	267	HU368R	E4	69.13	1756	36.62	930	17.75	451	36.62	930
H362WA	F6	18.19	462	9.00	229	6.81	173	10.50	267	HU461	F5	20.50	521	14.75	375	6.85	174	16.13	410
H362WC	F6	16.75	425	9.00	229	7.00	178	10.50	267	HU462	F5	20.50	521	14.75	375	6.85	174	16.13	410
H362WH	F5	18.19	462	9.00	229	6.81	173	10.50	267	HU463	F5	20.50	521	14.75	375	6.85	174	16.13	410
H363, N	F5	21.25	540	8.50	216	6.38	162	10.50	267	HU464	F5	29.00	737	23.25	591	8.75	222	24.88	632
H363NRB, RB	F5	21.25	540	8.50	216	6.38	162	10.50	267	HU465	E4	50.25	1276	33.88	861	10.13	257	33.88	861
H363WA	F6	21.85	462	9.00	229	6.81	173	10.50	267	HU466	E4	50.25	1276	33.88	861	10.13	257	33.88	861
H363WC	F6	21.85	555	9.00	229	6.81	173	10.50	267										

3 SAFETY SWITCHES

by Schneider Electric
www.schneider-electric.us

NEMA Type 4, 4X, 5, 7, 9 and 12

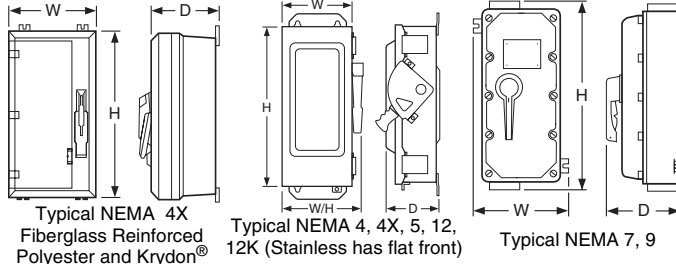

Table 3.33: Optional Copper Only Lug Kits

(See page 3-13 for pricing. See page 3-14 for terminal lug data for the series switches listed in the dimension table below.)

Rating (A)	Optional Lug Kit Cat. No.▲	Lug Wire Range Per Phase AWG/kcmil
30-60	CL0306F	(1) 14-8 Cu solid or 14-4 Cu strand
100	CL10F	(1) 14-8 Cu solid or 14-1/0 Cu strand
200	CL20F	(1) 6-250 Cu
400	CL40F	(1) 1-600 Cu plus (1) 6-250 Cu
600	CL60F	(2) 4-350 Cu

▲ One kit includes all phase line/load lugs for a 3-pole switch.

Table 3.34: Conduit Provisions

(NEMA 4X Fiberglass Reinforced Polyester and Krydron, NEMA 7 and 9.)

Rating (A)	Top and Bottom Endwall	
	NEMA 4X Fiberglass Reinforced Polyester and Krydron■	NEMA 7 and 9◆
30	3/4 in.	—
60	1-1/4 in.	3/4 in.
100	2 in.	1-1/4 in.
200	2-1/2 in.	2-1/2 in.

■ Hubs and hub drilling templates are provided for field-installation.

◆ Threaded conduit opening.

Cat. No.	Series	Approximate Dimensions							
		H		W		D		W/H	
		in.	mm	in.	mm	in.	mm	in.	mm
H60XFA	E1	15.93	405	9.87	251	6.96	177	9.87	251
H100XFA	E1	15.93	405	9.87	251	6.96	177	9.87	251
H221AWK, A	F6	14.60	371	6.63	168	4.96	125	7.55	192
H221DS	F6	14.93	379	7.22	183	5.11	130	8.67	220
H221-2AWK	F6	16.50	419	9.00	229	7.00	178	10.50	267
H222AWK, A	F6	14.60	371	6.63	168	4.96	125	7.55	192
H222DS	F6	14.93	379	7.22	183	5.11	130	8.67	220
H223AWK, A	F6	20.50	521	9.00	229	7.00	178	10.50	267
H223DS	F6	20.82	529	9.36	238	6.97	177	11.25	286
H224A,AWK	F6	29.00	737	17.25	438	8.75	216	18.63	473
H224DS	F6	29.00	737	17.25	438	8.75	216	18.63	473
H225AWK, DS	E4	46.25	1175	26.25	667	10.13	259	26.25	667
H225NAWK, NDS	E4	46.25	1175	26.25	667	10.13	259	26.25	667
H225XKA	C2	22.56	573	10.88	276	7.75	197	10.88	276
H226AWK, DS	E4	46.25	1175	26.25	667	10.13	259	26.25	667
H226NAWK, NDS	E4	46.25	1175	26.25	667	10.13	259	26.25	667
H227AWK, NAWK	E4	69.13	1756	36.62	930	17.75	451	36.62	930
H228AWK, NAWK	E4	69.13	1756	36.62	930	17.75	451	36.62	930
H265AWK, DS	E4	46.25	1175	26.25	667	10.13	259	26.25	667
H266AWK, A, DS	E4	46.25	1175	26.25	667	10.13	259	26.25	667
H267AWK, NAWK	E4	69.13	1756	36.62	930	17.75	451	36.62	930
H268AWK, NAWK	E4	69.13	1756	36.62	930	17.75	451	36.62	930
H321AWK, A	F6	14.60	371	6.63	168	4.96	125	7.55	192
H321DS	F6	14.93	379	7.22	183	5.11	130	8.67	220
H322AWK, A	F6	14.60	371	6.63	168	4.96	125	7.55	192
H322DS	F6	14.93	379	7.22	183	5.11	130	8.67	220
H323AWK, A	F6	20.50	521	9.00	229	7.00	178	10.50	267
H323DS	F6	20.82	529	9.36	238	6.97	177	11.25	286
H324A,AWK	F6	29.00	737	17.25	438	8.75	216	18.63	473
H324DS	F6	29.00	737	17.25	438	8.75	216	18.63	473
H325AWK, DS	E4	46.25	1175	26.25	667	10.13	259	26.25	667
H325NAWK, NDS	E4	46.25	1175	26.25	667	10.13	259	26.25	667
H326AWK, DS	E4	46.25	1175	26.25	667	10.13	259	26.25	667
H326NAWK, NDS	E4	46.25	1175	26.25	667	10.13	259	26.25	667
H327AWK, NAWK	E4	69.13	1756	36.62	930	17.75	451	36.62	930
H328AWK, NAWK	E4	69.13	1756	36.62	930	17.75	451	36.62	930
H361AWA	F7	16.50	419	9.00	229	7.00	178	10.50	267
H361AWC	F7	16.50	419	9.00	229	7.00	178	10.50	267
H361AWK, A	F6	14.60	371	6.63	168	4.96	125	7.55	192
H361DS	F6	14.93	379	7.22	183	5.11	130	8.67	220
H361DSWA	F7	16.87	428	8.92	227	5.11	130	10.81	275
H361DSWC	F7	16.87	428	8.92	227	5.11	130	10.79	274
H361DF	F1	16.50	419	11.00	279	8.80	224	11.00	279
H361DX	F1	19.40	493	11.40	290	8.60	218	11.40	290
H361SS	F6	14.93	379	7.22	183	5.11	130	8.67	220
H361-2AWK, A	F6	16.50	419	9.00	229	7.00	178	10.50	267
H362AWA	F7	16.50	419	9.00	229	7.00	178	10.50	267
H362AWC	F7	16.50	419	9.00	229	7.00	178	10.50	267
H362AWH	F6	16.50	419	9.00	229	7.00	178	10.50	267
H362AWK, A	F6	16.50	419	9.00	229	7.00	178	10.50	267
H362DS	F6	16.87	428	8.92	227	6.97	177	10.81	275

Cat. No.	Series	Approximate Dimensions							
		H		W		D		W/H	
		in.	mm	in.	mm	in.	mm	in.	mm
H362DSWA	F7	16.87	428	8.92	227	5.11	130	10.81	275
H362DSWC	F7	16.87	428	8.92	227	5.11	130	10.79	274
H362DF	F1	16.50	419	11.00	279	8.80	224	11.00	279
H362DX	F1	19.40	493	11.40	290	8.60	218	11.40	290
H362SS	F6	16.87	428	8.92	227	6.97	177	10.81	275
H363AWA	F7	20.50	521	9.00	229	7.00	178	10.50	267
H363AWC	F7	20.50	521	9.00	229	7.00	178	10.50	267
H363AWK, A	F6	20.50	521	9.00	229	7.00	178	10.50	267
H363DS	F6	20.82	529	9.36	238	6.97	177	11.25	286
H363DSWA	F7	20.82	529	9.36	238	6.97	177	11.25	286
H363DSWC	F7	20.82	529	9.36	238	6.97	177	11.25	286
H363DF	F1	24.80	630	13.70	348	12.00	305	13.70	348
H363DX	F1	25.25	641	11.40	290	8.60	218	11.40	290
H363SS	F6	20.82	529	9.36	238	6.97	177	11.25	286
H364A,AWK	F6	29.00	737	17.25	438	8.75	216	18.63	473
H364DS,NDS	F6	29.00	737	17.25	438	8.75	216	18.63	473
H364NA,NAWK	E1	31.30	795	26.30	668	11.80	300	26.30	668
H364DF	F6	29.00	737	17.25	438	8.75	216	18.63	473
H364SS	F6	29.00	737	17.25	438	8.75	216	18.63	473
H365AWK, DS	E4	46.25	1175	26.25	667	10.13	259	26.25	667
H365NAWK, NDS	E4	46.25	1175	26.25	667	10.13	259	26.25	667
H366AWK, DS	E4	46.25	1175	26.25	667	10.13	259	26.25	667
H366NAWK, NDS	E4	46.25	1175	26.25	667	10.13	259	26.25	667
H367AWK, NAWK	E4	69.13	1756	36.62	930	17.75	451	36.62	930
H368AWK, NAWK	E4	69.13	1756	36.62	930	17.75	451	36.62	930
H461AWK	F6	20.50	521	14.75	375	6.80	173	16.13	410
H461DS	F6	20.82	529	15.08	383	6.97	177	16.85	428
H462AWK	F6	20.50	521	14.75	375	6.80	173	16.13	410
H462DS	F6	20.82	529	15.08	383	6.97	177	16.85	428
H463AWK	F6	20.50	521	14.75	375	6.80	173	16.13	410
H463DS	F6	20.82	529	15.08	383	6.97	177	16.85	428
H464AWK	F6	29.00	737	23.25	591	8.75	222	24.88	632
H464DS	F6	29.00	737	23.25	591	8.75	222	24.88	632
H465AWK	E4	46.25	1175	32.50	826	10.13	259	32.50	826
H663AWK	F6	20.50	521	14.75	375	6.80	173	16.13	410
H663DS	F6	20.82	529	15.08	383	6.97	177	16.85	428
H664AWK	F6	29.00	737	23.25	591	8.75	222	24.88	632
H664DS	F6	29.00	737	23.25	591	8.75	222	24.88	632
HU265AWK, DS	E4	46.25	1175	26.25	667	10.13	259	26.25	667
HU266AWK, DS	E4	46.25	1175	26.25	667	10.13	259	26.25	667
HU267AWK	E4	69.13	1756	36.62	930	17.75	451	36.62	930
HU268AWK	E4	69.13	1756	36.62	930	17.75	451	36.62	930
HU361AWA	F7	16.50	419	9.00	229	7.00	178	10.50	267
HU361AWC	F7	16.50	419	9.00	229	7.00	178	10.50	267
HU361AWK, A	F6	14.60	371	6.63	168	4.96	125	7.55	192
HU361DS	F6	14.93	379	7.22	183	5.11	130	8.67	220
HU361DSWA	F7	16.87	428	8.92	227	5.11	130	10.81	275
HU361DSWC	F7	16.87	428	8.92	227	5.11	130	10.79	274
HU361DF	F1	16.50	419	11.00	279	8.80	224	11.00	279
HU361DX	F1	19.40	493	11.40	290	8.60	218	11.40	290
HU361SS	F6	14.93	379	7.22	183	5.11	130	8.67	220
HU362AWA	F7	16.50	419	9.00	229	7.00	178	10.50	267
HU362AWC	F7	16.50	419	9.00	229	7.00	178	10.50	267
HU362AWH	F6	16.50	419	9.00	229	7.00	178	10.50	267
HU362AWK, A	F6	16.50	419	9.00	229	7.00	178	10.50	267
HU362DS	F6	16.87	428	8.92	227	6.97	177	10.81	275
HU362DSWA	F7	16.87	428	8.92	227	5.11	130	10.81	275
HU362DSWC	F7	16.87	428	8.92	227	5.11	130	10.79	274
HU362DF	F1	16.50	419	11.00	279	8.80	224	11.00	279
HU362DX	F1	19.40	493	11.40	290	8.60	218	11.40	290
HU362SS	F6	16.87	428	8.92	227	6.97	177	10.81	275
HU363AWA	F7	20.50	521	9.00	229	7.00	178	10.50	267
HU363AWC	F7	20.50	521	9.00	229</				



30–100 A Types DT, DTU (Series F)

- Fusible (DT) and non-fusible (DTU) switches available
- Manually-operated switch suitable for use in accordance with article 702 of the NEC, ANSI/NFPA 70
- Standards: UL 98, NEMA KS1, CSA, and NOM
- Modular design—switch handle, lock-plate, switch mechanism; line and load bases are field replaceable
- UL Listed short circuit current ratings up to 200 kA (using Class R, J, or T fuses—see table for rating)
- Load make/break rated
- Meets NEMA hp ratings
- Dual cover interlock
- May be padlocked ON (I) or OFF (O)
- Lock-off accepts up to three padlocks
- Side-opening door
- Quick make / quick break mechanism
- Meets NEMA requirements as heavy duty switch
- Field-installed electrical interlock kits
- Field-installed neutral assembly kits (2P and 3P switches)
- UL Listed as suitable for use as service equipment
- Supplied as standard for switching one load between two power sources, and may be field-converted to switch on power source between two loads.



30 (Series T4), 200–600 A Types 82,000 and 200 A DTU (Series E, A)

- Non-fusible
- Designed for manual transfer of loads from one supply to another
- UL Listed switches are suitable for use in accordance with Article 702 of the National Electrical Code, ANSI / NFPA 70
- All 82,000 and DTU double throw switches are continuous duty rated for their nameplate ampere rating
- The 82,000 and DTU (Series E, A) switches are load make/break rated
- UL Listed as suitable for use as service equipment
- Horsepower rated only as footnoted.

Field-Installed Accessories:

- Neutral
- Electrical Interlock
- Grounding Terminals

30–100 A DT, DTU (Series F)
NEMA 1



82,000 Line
NEMA 1

System	Rating (A)	Current Series	NEMA 1		NEMA 3R		NEMA 4,4X,5 304 Stainless Steel		NEMA 12 Gasketed		Horsepower Ratings ▲■			
			Cat. No.	\$ Price	Cat. No.	\$ Price	Cat. No.	\$ Price	Cat. No.	\$ Price	240 Vac		250 Vdc ♦	
											Std.	Max.		

Table 3.35: Fusible—2P, 240 Vac—250 Vdc

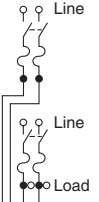
	100	F	DT223	2379.00	DT223RB	3056.00	—	—	—	—	7.5	15 ★	15	30 ★	20
---	-----	---	-------	---------	---------	---------	---	---	---	---	-----	------	----	------	----

3P, 240 Vac—250 Vdc





	30	F	DT321	1646.00	DT321RB	2216.00	—	—	—	—	1.5 ▼	3 ★	3 ▼	7.5 ★	5
	60	F	DT322	1970.00	DT322RB	2612.00	—	—	—	—	3 ▼	7.5 ★	10 ▼	15 ★	10
	100	F	DT323	3104.00	DT323RB	3725.00	—	—	—	—	7.5 ▼	15 ★	15 ▼	30 ★	20

Table 3.36: Non-Fusible—2P, 240 Vac—250 Vdc

	60	F	DTU222	962.00	—	—	—	—	—	—	—	—	10	—	10 △
	100	F	DTU223	1371.00	DTU223RB	1347.00	—	—	—	—	—	—	15	—	20 △
	30	T4	92251 □	585.00	—	—	—	—	—	—	—	—	—	—	—
	200	E	82254 ◐	1815.00	DTU224NRB □ ◐ ◑	2177.00	—	—	H82254	4671.00	15	—	—	—	—
	400	A	82255 ◐ ◑	5850.00	82255R □	8715.00	—	—	H82255 □	10335.00	15	—	—	—	—

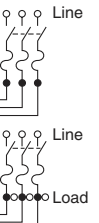
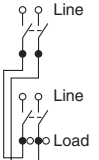
3P, 240 Vac—250 Vdc

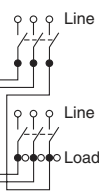
	30	F	DTU321	804.00	—	—	—	—	—	—	—	3 ★	5 ▼	10 ★	5 △
	60	F	DTU322	1119.00	—	—	—	—	—	—	—	—	10 ▼	15 ★	10 △
	100	F	DTU323	1764.00	DTU323RB	1953.00	—	—	—	—	—	—	15 ▼	30 ★	20 △
	30	T4	92351 □	687.00	—	—	—	—	—	—	—	—	—	—	—
	200	E	82354 □	2564.00	DTU324NRB □ ◐	3005.00	—	—	H82354 □ ☆	5408.00	15	—	—	—	—
	200	E	DTU324N □ ◐	2798.00	—	—	—	—	—	—	15	—	—	—	—
	400	A	82355 ◐ ◑	8040.00	82355R □ ◐ ◑	13038.00	—	—	H82355 ◐ ◑	11715.00	—	—	—	—	—
	600	A	DTU326	12555.00	DTU326R	13890.00	—	—	—	—	—	125	—	—	50

4P, 240 Vac

	30	T4	92451 □	953.00	—	—	—	—	—	—	—	—	—	—	—
	200	E	82454	5184.00	82454R ◐	7517.00	—	—	H82454 ▼	6779.00	15 ▼	—	—	—	—
	400	A	82455 ◐	11505.00	82455R	16200.00	—	—	H82455	15975.00	—	—	—	—	—
	600	A	DTU426	20355.00	DTU426R	20595.00	—	—	—	—	—	125	—	—	50

- ▲ Refer to page 7-31 for additional motor application data. The starting current of motors or more than standard horsepower may require the use of fuses with appropriate time delay characteristics.
- Std.—Using fast acting one time fuses. Max.—Using dual element time delay fuses.
- ◐ For switching dc, use two switching poles.
- ★ If used on corner grounded delta systems, install neutral and use outer switching pole for ungrounded conductors.
- ▼ Use outer switching poles.
- △ Maximum rating.
- 240 Vac only.
- ◊ Neutral included with device.
- ☆ Suitable for use as service equipment.
- ▽ Hp rating applies only to H82454.
- ◑ 250 V dc rated.

600 V Double Throwpage 3-18
 Accessoriespage 3-19
 Application Datapage 3-20
 Dimensions: 30–100 A (Series F)page 3-21
 Dimensions: 30, 200–600 A (Series E, T4, A)page 3-22

Table 3.37: 600 V Double Throw Safety Switches

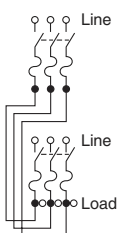
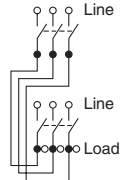
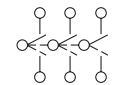
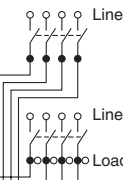
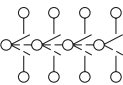
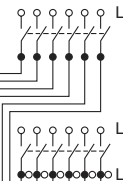
System	Rating (A)	Current Series	NEMA 1		NEMA 3R		NEMA 4,4X,5 304 Stainless Steel		NEMA 12 Gasketed		Horsepower Ratings ▲ ◊																	
											240 Vac		480 Vac		600 Vac		Vdc■											
			Cat. No.	\$ Price	Cat. No.	\$ Price	Cat. No.	\$ Price	Cat. No.	\$ Price	3Ø	3Ø	3Ø	3Ø	3Ø	3Ø	250	600										
Fusible 3P, 600 Vac—600 Vdc																												
	30	F	DT361	2016.00	DT361RB	2678.00	—	—	—	—	—	—	—	5	15	7.5	20	5	15									
	60	F	DT362	2111.00	DT362RB	3135.00	—	—	—	—	—	—	—	15	30	15	50	—	30									
	100	F	DT363	3686.00	DT363RB	4427.00	—	—	—	—	—	—	—	25	60	30	75	—	50									
Non-Fusible 3P, 600 Vac—600 Vdc												1Ø★	3Ø■	1Ø★	3Ø■	1Ø★	3Ø											
	30	F	DTU361	879.00	DTU361RB	1544.00	—	—	—	—	5	10	7.5	20	10	30	5	15										
	60	F	DTU362	1254.00	DTU362RB	2045.00	DTU362DS	6306.00	DTU362AWK	3635.00	10	20▼	25	50□	30	60□	10	30										
	100	F	DTU363	2036.00	DTU363RB	3425.00	DTU363DS	9414.00	DTU363AWK	3894.00	20	40◇	40	75◇★	40	75◇	20	50										
	200	E	82344▼◊	2783.00	82344RB▼◊	5868.00	82344DS▼‡	11415.00	H82344*▼◇	7503.00	—	—	—	15◊	—	—	—	—										
	400	A	82345◊	8213.00	82345R◊◊	13140.00	82345DS◊◊	15675.00	H82345	12105.00	—	—	—	—	—	—	—	—										
	600	A	DTU366◊	13890.00	DTU366R◊	19800.00	—	—	DTU366AWK◊	21675.00	—	125	—	250	—	350	50	—										
Non-Fusible 4P, 600 Vac—600 Vdc												2Ø	3Ø	2Ø	3Ø	2Ø	3Ø											
	60	F	DTU462	3035.00	Use NEMA 12	—	DTU462DS	6683.00	DTU462AWK	4184.00	20	20	40	50	50	60	10	30										
	100	F	DTU463	3851.00	—	—	DTU463DS	9978.00	DTU463AWK	6123.00	30	40	50	75	50	75	20	30										
	200	E	82444◊	6143.00	82444R◊	8130.00	82444DS◊	15105.00	H82444*▼◇	7143.00	—	—	—	—	—	—	—	—										
	400	A	82445◊◊	12578.00	82445R◊◊	16800.00	—	—	H82445◊	16845.00	—	—	—	—	—	—	—	—										
	600	A	DTU466◊	20355.00	DTU466R◊	23475.00	—	—	—	—	—	125	—	250	—	350	50	—										
Non-Fusible 6P, 600 Vac—600 Vdc												1Ø	3Ø	1Ø	3Ø	1Ø	3Ø											
	60	F	—	—	—	—	—	—	DTU662AWK	8474.00	—	20	—	50	—	60	10	30										
	100	F	—	—	—	—	—	—	DTU663AWK	12735.00	—	40	—	75	—	75	20	50										

- ▲ Refer to page 7-31 for additional motor application data. The starting current of motors or more than standard horsepower may require the use of fuses with appropriate time delay characteristics.
- If used on corner grounded delta systems, install neutral and use outer switching pole for ungrounded conductors.
- ◆ For switching dc, use two switching poles.
- ★ Use outer switching poles.
- ▼ Maximum Hp is 15 for corner grounded delta systems.
- △ Maximum Hp is 30 for corner grounded delta systems.
- Use 75°C #4 Cu or #2 Al conductors only.
- ◇ Use 75°C #1 Cu conductors only.
- ★ Maximum Hp is 60 for corner grounded delta systems.
- ▼ 480 Vac maximum only, 250Vdc.
- ◊ Standard Hp rating.
- * Not suitable for use as service equipment.
- ◇ 600 Vac max.
- ◊ 250 V dc rated.
- ◊ Std.—Using fast acting one time fuses. Max.—Using dual element time delay fuses.
- (Non-fusible switches have max rating unless noted.)
- Complete rating on switch is NEMA 3R or 12.
- For 3R applications, remove drain screw from bottom endwall.
- ◆ H82 ... and H92 ... devices are NEMA 12 only, intended for use indoors only.
- ‡ Not UL Listed.

240 V Double Throw page 3-17
 Accessories page 3-19
 Application Data page 3-20
 Dimensions: 30–100 A (Series F) page 3-21
 Dimensions: 30, 200–600 A (Series E, T4, A) page 3-22

3 SAFETY SWITCHES

Table 3.38: Neutral Assembly

Switch	Field-Installed Standard Neutral Kit Cat. No.	Terminal Data AWG/kcmil	\$ Price	Field-Installed Copper only Neutral Kit Cat. No.	Terminal Data AWG/kcmil	\$ Price
30-100 A Type DT, DTU (Series F) (2- and 3-pole switches only)	SN0310	14-1/0 Al/Cu	114.00	SN0310C	14-1/0 Cu	120.00
30 A (Series T4) (2- and 3-pole switches only)	▲	▲	908.00	—	—	—
200 A Type 82000 and DTU (Series E) ■	▲	▲	1110.00	—	—	—
400 A Type 82000	DT400N	(1) 4-600kcmil or (2) 1/0-250kcmil	105.00	—	—	—
600 A Type DTU (Series A)	DT600NKD	250-500kcmil	452.00	—	—	—

▲ For Type 82,000 switches, neutral is available factory-installed on 2P and 3P double throw switches. Not UL Listed. To order, add suffix N to the standard catalog number and add the above price to the list price of the switch. For DTU switches, neutral is factory-installed in standard device and is UL Listed.
■ Neutral assembly catalog number DT200N can be added to 4P Type 82000 switches in the field.

Table 3.39: Electrical Interlocks (For Electrical Interlock Contact Ratings, see Supplemental Digest page 2-4.)

Switch	Field-Installed Electrical Interlock Kit Cat. No. ♦	\$ Price	Factory-Installed \$ Price Adder Per Switch
30-100 A Type DT, DTU (Series F)	EIK1, EIK2 ★	311.00	905.00▼
200 A Type 82000 and DTU (Series E) △	□	—	1113.00▼
400 A Type 82000	EK400DTU2	260.00	—
600 A Type DTU (Series A)	DS200EK2D	438.00	—

♦ Electrical interlock kit catalog numbers with "1" suffix indicate one normally open and normally closed contact; "2" indicates two normally open and two normally closed contacts. See page 3-11 for electrical interlock ratings.
★ 30-100 A Type DT, DTU (Series F) switches contain (2) separate switching mechanisms. Each mechanism will accept an electrical interlock. Some applications may therefore require (2) electrical interlocks.
▼ 30-100 A Type DT, DTU (Series F) switches with factory-installed electrical interlocks installed are UL Listed and interlocks are furnished with 2 N.O./2 N.C. contacts installed in both "ON" positions. To order, add suffix EI to standard catalog number.
△ Electrical interlock EK400DTU2 can be added to 4-pole Type 82000 switches in the field.
□ Type 82000 and DTU switches are available with electrical interlock factory-installed only. Not UL listed. Electrical interlocks are furnished with 2 N.O./N.C. contacts and are installed in both "ON" positions. To order, add suffix EI to standard switch catalog number.

Table 3.40: Service Grounding Kit (Required for service equipment use.)

Switch	Field-Installed Service Grounding Lug Kit Cat. No.	Terminal Data AWG/kcmil	\$ Price
30-100 A Type DT, DTU (Series F)	Included	Included	std.
30 A Type 92,000	DT30SG	(4) 14-4 Cu/Al	29.40
200 A Type 82000 and DTU (Series E)	DT100SG	(3) 14-1/0 Cu/Al	30.00
400 A Type 82000	PKOGTA2 (2 required)	(4) 10-2/0 Cu or (4) 6-2/0 Al	55.00
600 A Type 82000 (Series A)	DS468GKD	6-250kcmil	309.00

Table 3.41: Class R Fuse Kits

When installed, this kit rejects all but Class R fuses. Kits are available for field installation. For factory installation, add "CLR" suffix to catalog number.

Switch	Series Number	Class R Fuse Kit Cat. No.	\$ Price	Factory-Installed	\$ Price
Class R Fuse Kits—240 V (two kits per 3P switch)					
30 A	F5	RFK03	24.50		390.00
60 A	F5	RFK06	25.50		390.00
100 A	F5	RFK10	47.70		390.00
Class R Fuse Kits—600 V (two kits per 3P switch)					
30 A	F5	RFK06	25.50		390.00
60 A	F5	RFK06H	25.50		390.00
100 A	F5	RFK10	47.70		390.00

Key Interlock Systems

For factory-installed key interlocks, refer to page 3-13.

Phenolic Legend Plate

For factory-installed phenolic legend plates, refer to Supplemental Digest page 2.4.

Lock-On Provisions—UL Listed

30-100 A type DT, DTU (Series F) and type 92,000 included on standard device.

Type 82,000 and 200 A DTU (Series E) available factory-installed. Add SPLO to catalog number and add \$410. to list price.

Table 3.42: Rainproof Bolt-On Hubs—for use on NEMA 3R Enclosures

Conduit Size	3/4	1	1-1/4	1-1/2	2	2-1/2	3	3-1/2	4	Closing Cap
Hub Cat. No.	B075	B100	B125	B150	B200	B250	B300	B350	B400	BCAP
\$ Price Each ♦	33.30	33.30	33.30	33.30	61.00	102.00	186.00	300.00	368.00	3.80

Note: NEMA 3R rainproof enclosures with catalog number ending in RB have a bolt-on closing cap factory-installed. Order bolt-on hubs separately from table above. For more details see page 1-13. Hubs through size 2-1/2 in. can be directly installed on RB devices. Devices requiring 3 in. or larger hubs must have holes cut in the field. Gaskets are provided on 3 in. and larger hubs.

Note: All hubs are UL Listed for indoor and rainproof applications and suitable for use with conduit having ANSI standard taper pipe thread.

♦ See Discount Schedule.

Table 3.43: Watertight Hubs—for use on NEMA 4, 4X and 5 Stainless Steel and NEMA 12 Enclosures

Conduit Trade Size	1/2	3/4	1	1-1/4	1-1/2	2	2-1/2	3	3-1/2	4
Standard-Zinc Hub Cat. No.	H050	H075	H100	H125	H150	H200	H250	H300	H350	H400
Zinc \$ Price Each	31.10	45.00	47.10	54.00	83.00	120.00	138.00	177.00	282.00	381.00
Chrome Plated Hub Cat. No.	H050CP	H075CP	H100CP	H125CP	H150CP	H200CP	—	—	—	—
Chrome Plated \$ Price Each	40.70	56.00	64.00	67.00	96.00	137.00	—	—	—	—

240 V Double Throwpage 3-17
600 V Double Throwpage 3-18
Application Datapage 3-20
Dimensions: 30-100 A (Series F)page 3-21
Dimensions: 30, 200-600 A (Series E, T4, A)page 3-22



Situations Requiring Fuses

30–100 A Type DT (Series F):

Select DT switches from pages 3-17, 3-18, which have provisions for accepting fuses.

30 A, 200–600 A Type 82,000 (Series E, T4, A), all DTU devices:

Use the non-fusible double throw switches from pages 3-17, 3-18 in conjunction with standard fusible devices, and install them according to diagram 1 or 2, below.

Table 3.44: UL Listed Short Circuit Current Ratings

Switch Type	Ampere Rating	Voltage Rating	UL Listed Fuse Class	Short Circuit Current Rating ▲ (A)
Type DT (Series F)	30–100 A	240 V or 600 V	H, K	10,000
			R, J	200,000
Type DTU ■ (Series F)	30–100 A	240 V or 600 V	H or K	10,000 ◆
			R, J or T	200,000
DTU224NRB and DTU324NRB (Series E)	200 A	240 V	H, K	10,000 ◆
DTU324N (Series E)	200 A	240 V	H, K	10,000 ◆
			R, J	100,000
Type 82,000	all	240 V	H, K	10,000 ◆
			R, J	100,000 ★
			H, K	10,000 ◆
	600 V	240 V	H, K	10,000 ◆
			R, J	100,000 ★
Type DTU (A series)	600 A	240 V or 600 V	H, K	10,000
			R, J, T	100,000

- ▲ Rating applies to AC only. The UL Listed short circuit current rating for non-fusible switches is based on the switch being used in conjunction with the corresponding fuse type. Evaluation of non-fusible switches in conjunction with molded case circuit breakers has not been performed.
- The DTU361 and DTU361RB are also suitable for use on a circuit capable of delivering not more than (A) 18 kA, 600 Vac maximum when protected by Type FH circuit breaker rated 30 A maximum or (B) 14 kA, 600 Vac maximum when protected by Type FA circuit breaker rated 30 A maximum.
- ◆ Any brand of circuit breaker or fuse not exceeding the ampere rating of the switch may be used ahead of a non-fusible safety switch when there is up to 10 kA short circuit current available.
- ★ 400 A 82,000 switch is only 10 kA.

Table 3.45: Terminal Lug Data for Type DT, DTU (Series F) Double Throw Safety Switches

Switch	Wires per Phase	NEMA 1, 3R, 4, 4X, 12			Optional Copper Only Lug
		Wire Range Wire Bending Space Per NEC Table 373-6 AWG/kcmil	Standard Lug Wire Range AWG/kcmil	Optional Compression Lug Field-Installed	
30–60 A Type DT, DTU (Series F)	1	12–2 Al or 14–2 Cu	12–2 Al or 14–2 Cu	C10-14, D8-14, or E6-14 ▼	See pages 3-13 and 3-15 for appropriate kit. Order two kits per switch.
100 A Type DT, DTU (Series F)	1	12–1/0 Al or 14–1/0 Cu	12–1/0 Al or 14–1/0 Cu	VCEL02114S1 △	

- ▼ Thomas and Betts catalog numbers.
- △ Hubbell Versa-Crimp® catalog numbers.

Table 3.46: Terminal Lug Data for Types 82,000 and for A and E-Series DTU devices □

Switch	Wires per Phase	Wire Range Wire Bending Space Per NEC Table 373-6 AWG/kcmil	Lug Wire Range AWG/kcmil	Optional Compression Lugs Field-Installed
30 A (Series T4) ◇	1	14–8 Al/Cu	12–2 Al or 14–2 Cu	—
200	1	6–300 Al/Cu	6–300 Al/Cu	VCEL030516H1 ★
400	1 or 2	1/0–600 Al/Cu or 1/0–300 Al/Cu	1/0–600 Al/Cu	—
600	2	250–500 Al/Cu	250–500 Al/Cu	—

- 200–600 A switches suitable for 75°C conductors.
- ◇ 30 A switches suitable for 60°C or 75°C conductors.
- ★ Hubbell Versa-Crimp® catalog numbers.

240 V Double Throw page 3-17
 600 V Double Throw page 3-18
 Accessories page 3-19
 Dimensions: 30–100 A (Series F) page 3-21
 Dimensions: 30, 200–600 A (Series E, T4, A) page 3-22

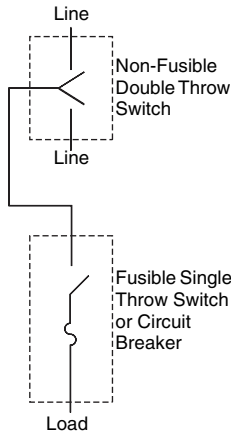

Diagram 1

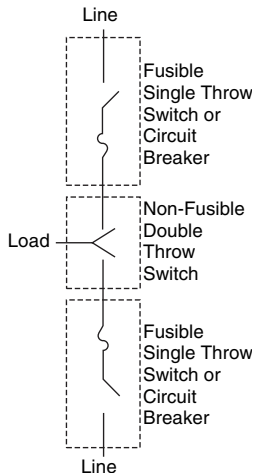
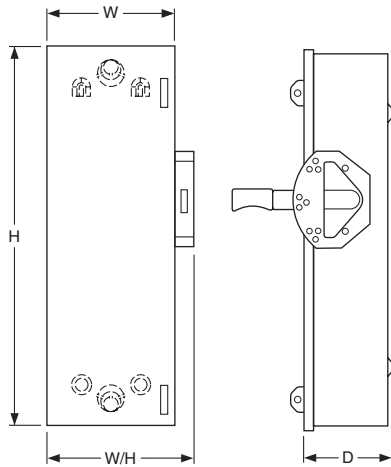
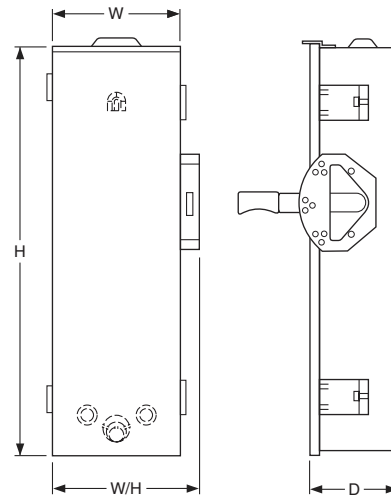

Diagram 2



NEMA 1



NEMA 3R

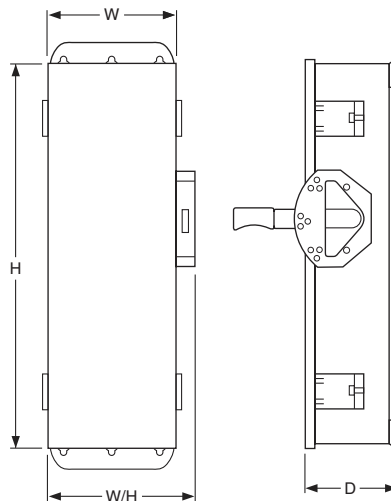

NEMA 4, 4X, 5 and 12

Table 3.47: 30–100 A Type DT, DTU (Series F)—Approximate Dimensions

Cat. No.	Series	H		W		W/H		D	
		in.	mm	in.	mm	in.	mm	in.	mm
DT223	F5	38.00	965	9.88	251	11.13	283	6.75	171
DT223RB	F5	38.00	965	6.87	174	8.12	206	6.60	168
DT321	F5	38.00	965	10.25	260	11.50	292	6.75	171
DT321RB	F5	38.00	965	10.25	260	11.80	300	6.60	168
DT322	F5	38.00	965	10.25	260	11.50	292	6.75	171
DT322RB	F5	38.00	965	10.25	260	11.80	300	6.60	168
DT323	F5	38.00	965	9.88	251	11.13	283	6.75	171
DT323RB	F5	38.00	965	6.87	174	8.12	206	6.60	168
DT361	F5	38.00	965	10.25	260	11.50	292	6.75	171
DT361RB	F5	38.00	965	10.25	260	11.80	300	6.60	168
DT362	F5	38.00	965	10.25	260	11.50	292	6.75	171
DT362RB	F5	38.00	965	10.25	260	11.80	300	6.60	168
DT363	F5	38.00	965	9.88	251	11.13	283	6.75	171
DT363RB	F5	38.00	965	6.87	174	8.12	206	6.60	168
DTU222	F5	29.94	760	10.25	260	11.96	304	6.93	176
DTU223	F5	29.94	760	10.25	260	11.96	304	6.93	176
DTU223RB	F5	30.50	775	10.25	260	11.96	304	6.93	176
DTU321	F5	29.94	760	10.25	260	11.96	304	6.93	176
DTU322	F5	29.94	760	10.25	260	11.96	304	6.93	176
DTU323	F5	29.94	760	10.25	260	11.96	304	6.93	176
DTU323RB	F5	30.50	775	10.25	260	11.96	304	6.93	176
DTU361	F5	29.94	760	10.25	260	11.96	304	6.93	176
DTU361RB	F5	30.50	775	10.25	260	11.96	304	6.93	176
DTU362	F5	29.94	760	10.25	260	11.96	304	6.93	176
DTU362AWK	F6	29.94	760	10.25	260	11.96	304	6.93	176
DTU362DS	F6	30.26	769	10.25	260	11.50	292	7.12	181
DTU362RB	F5	30.50	775	10.25	260	11.96	304	6.93	176
DTU363	F5	29.94	760	10.25	260	11.96	304	6.93	176
DTU363AWK	F6	29.94	760	10.25	260	11.96	304	6.93	176
DTU363DS	F6	30.26	769	10.25	260	11.50	292	7.12	181
DTU363RB	F5	30.50	775	10.25	260	11.96	304	6.93	176
DTU462	F5	29.94	760	10.25	260	11.96	304	6.93	176
DTU462AWK	F6	30.26	769	15.50	394	16.75	425	7.12	181
DTU462DS	F6	30.26	769	15.50	394	16.75	425	7.12	181
DTU463	F5	29.94	760	10.25	260	11.96	304	6.93	176
DTU463AWK	F6	30.26	769	15.50	394	16.75	425	7.12	181
DTU463DS	F6	30.26	769	15.50	394	16.75	425	7.12	181
DTU662AWK	F6	30.26	769	15.50	394	16.75	425	7.12	181
DTU663AWK	F6	30.26	769	15.50	394	16.75	425	7.12	181

240 V Double Throw page 3-17
 600 V Double Throw page 3-18
 Accessories page 3-19
 Application Data page 3-20
 Dimensions: 30, 200–600 A (Series E, T4, A) page 3-22

Table 3.48: 30, 200–600 A Types 82,000 and E-Series DTU devices, NEMA 1 and 3R—Approximate Dimensions

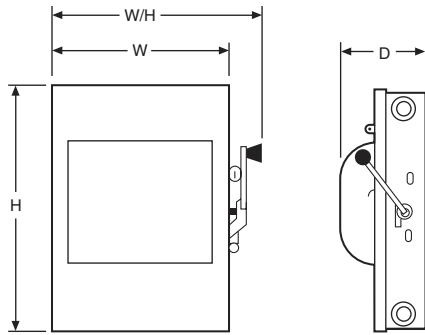

NEMA 1

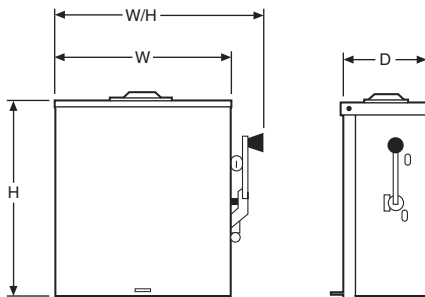

DTU—200 A
NEMA 3R

Cat. No.	Series	H		W		W/H		D	
		in.	mm	in.	mm	in.	mm	in.	mm
DTU224NRB ▲	E1	32.50	826	20.63	524	24.00	610	10.63	270
82254 ▲	E1	30.88	784	15.75	400	19.63	499	9.75	248
82254NW ▲	E1	30.88	784	20.00	508	23.88	607	11.75	298
82344 ▲	E2	30.88	784	20.00	508	23.88	607	11.75	298
82344RB ▲	E1	32.50	826	20.63	524	24.00	610	10.63	270
82354	E1	30.88	784	20.00	508	23.88	607	11.75	298
92251	T4	10.00	254	8.00	203	9.75	248	4.75	121
82344DS	E1	30.88	784	20.00	508	23.88	607	11.75	298
DTU324N	E1	32.50	826	24.50	622	26.25	667	10.63	270
DTU324NRB	E1	32.50	826	24.50	622	26.25	667	10.63	270
H82344	E2	32.50	826	24.50	622	26.25	667	10.63	270
H82444 ▲	E2	32.50	826	30.21	767	33.61	854	10.63	270
H82454	E3	32.50	826	30.21	767	33.61	854	10.63	270
82454	E3	38.00	965	29.62	753	33.02	839	10.63	270
82444	E3	38.00	965	29.62	753	33.02	839	10.63	270
82454R ▲	E3	38.00	965	29.62	753	33.02	839	10.63	270
82444R	E3	38.00	965	29.62	753	33.02	839	10.63	270
H82254	E3	32.50	826	24.50	622	26.25	667	10.63	270
H82354	E3	32.50	826	24.50	622	26.25	667	10.63	270
82444DS ▲	E3	38.00	965	29.62	753	33.02	839	10.63	270
82255 ▲	A1	38.50	978	26.10	663	29.51	750	10.63	270
82255R	A1	39.00	991	26.62	676	30.02	763	10.63	270
82345 ▲	A1	38.50	978	26.10	663	29.51	750	10.63	270
82345DS ▲	A1	39.00	991	26.62	676	30.02	763	10.63	270
82345R ▲	A1	39.00	991	26.62	676	30.02	763	10.63	270
82355 ▲	A1	38.50	978	26.10	663	29.51	750	10.63	270
82355R ▲	A1	39.00	991	26.62	676	30.02	763	10.63	270
82445	A1	38.50	978	30.10	765	33.50	851	10.63	270
82445R	A1	39.00	991	30.21	767	33.61	854	10.63	270
82455 ▲	A1	38.50	978	30.10	765	33.50	851	10.63	270
82455R	A1	39.00	991	30.21	767	33.61	854	10.63	270
H82255	A1	39.00	991	26.62	676	30.02	763	10.63	270
H82345	A1	39.00	991	26.62	676	30.02	763	10.63	270
H82355	A1	39.00	991	26.62	676	30.02	763	10.63	270
H82445	A1	39.00	991	30.21	767	33.61	854	10.63	270
H82455	A1	39.00	991	30.21	767	33.61	854	10.63	270
DTU326	A1	63.31	1608	23.66	601	24.46	621	8.88	226
DTU426	A1	63.31	1608	27.00	686	27.80	706	8.88	226
DTU366	A1	63.31	1608	23.66	601	24.46	621	8.88	226
DTU466	A1	63.31	1608	27.00	686	27.80	706	8.88	226
DTU326R	A1	63.76	1619	23.66	601	24.46	621	8.88	226
DTU426R	A1	63.76	1619	27.00	686	27.80	706	8.88	226
DTU366R	A1	63.76	1619	23.66	601	24.46	621	8.88	226
DTU466R	A1	63.76	1619	27.00	686	27.80	706	8.88	226
DTU366AWK	A1	63.76	1619	23.66	601	24.46	621	8.88	226

▲ 250 V dc rated.

240 V Double Throw page 3-17
 600 V Double Throw page 3-18
 Accessories page 3-19
 Application Data page 3-20
 Dimensions: 30–100 A (Series F) page 3-21