

**SA6A: Ultrasonic Analog Distance Detection Sensors****Key features of the SA6A include:**

- Noise protection is available in two modes of operation
- Fuzzy logic eliminates the adverse effects of temperature fluctuation and air turbulence
- Hold mode is ideal for sensing liquid levels without the chatter often caused by surface ripples
- Three sensing ranges optimize resolution:  
Short range: 1.97" to 11.81" ( $\pm 0.04$ ")  
Medium range: 3.94" to 39.37" ( $\pm 0.08$ ")  
Long range: 7.87" to 78.74" ( $\pm 0.19$ ")
- Shape, size, color, and material do not impair high-precision measurement
- Select analog output (4 to 20mA) for continuous values; use digital output (on/off); or use both
- An eight-dot LED meter provides a dynamic display of detected positions



<b>General Specifications</b>	<b>Power Voltage</b>	12 to 24V DC (ripple 10% maximum)
	<b>Current Draw</b>	100mA (maximum)
	<b>Dielectric Strength</b>	Between live and dead parts: 1000V, 50/60Hz, 1 minute
	<b>Insulation Resistance</b>	Between live and dead parts: 100M $\Omega$ (minimum) with 500V DC megger
	<b>Operating Temperature</b>	-10° to +60°C (performance will be adversely affected if the sensor becomes coated with ice)
	<b>Storage Temperature</b>	-30°C to +70°C
	<b>Operating Humidity</b>	35 to 70% RH (avoid condensation)
	<b>Vibration Resistance</b>	Damage limits: 10 to 55Hz, amplitude 1.5mm p-p, 2 hours in each of 3 axes (when de-energized)
	<b>Shock Resistance</b>	Damage limits: 500m/sec <sup>2</sup> (approximately 50G) 3 shocks in each of 3 axes
	<b>Noise Resistance</b>	Power line: 500V; Pulse width: 1 $\mu$ sec, 50/60Hz (using a noise simulator)
	<b>Material</b>	Housing: diecast zinc; Coverplate: polyarylate
	<b>Degree of Protection</b>	IP65 — IEC Pub 529: Sensors rated IP65 are dust-tight, water-resistant, and perform best when not subjected to heavy particle or water blasts
	<b>Cable</b>	Cable type: 6-core cabtyre cable 0.2mm <sup>2</sup> , 6'-6-3/4" (2m) long
	<b>Weight</b>	Short and medium range: 260g; Long range: 270g
<b>Dimensions</b>	Short and medium range: 1.96"H x 0.82"W x 3.19"D (50mm H x 21mm W x 81mm D) Long range: 3.19"H x 1.14"W x 3.33"D (50mm H x 29mm W x 84.5mm D)	

### Part Numbers: Short Sensing Range

Part Number	Output	Sensing Range (A Mode)	Sensing Range (B Mode)	Linearity/Resolution
SA6A-L1K4S SA6A-L1L4S	NPN PNP	3.94" to 11.81" ± 0.4" (100mm to 300mm ± 10mm)	1.97" to 11.81" ± 0.4" (50mm to 300mm ± 10mm)	± 0.04" (1mm)

### Part Numbers: Medium Sensing Range

Part Number	Output	Sensing Range (A Mode)	Sensing Range (B Mode)	Linearity/Resolution
SA6A-LK4S SA6A-LL4S	NPN PNP	7.87" to 39.37" ± 0.8" (200mm to 1m ± 20mm)	3.94" to 39.37" ± 0.8" (100mm to 1m ± 20mm)	± 0.08" (2mm)

### Part Numbers: Long Sensing Range

Part Number	Output	Sensing Range (A Mode)	Sensing Range (B Mode)	Linearity/Resolution
SA6A-L2K4S SA6A-L2L4S	NPN PNP	15.75" to 78.74" ± 1.6" (400mm to 2m ± 40mm)	7.87" to 78.74" ± 1.6" (200mm to 2m ± 40mm)	± 0.19" (5mm)

	SA6A-L1K4S, -L1L4S	SA6A-LK4S, -LL4S	SA6A-L2K4S, -L2L4S
<b>Analog Output</b>	4 to 20mA (fixed range)	4 to 20mA (fixed range)	4 to 20mA (fixed range)
<b>Error</b>	± 0.08mA	± 0.04mA	± 0.05mA
	Defined as how accurate the actual analog output is, with respect to distance		
<b>Resolution</b>	± 0.04" (1mm)	± 0.08" (2mm)	± 0.19" (5mm)
	Defined as the smallest object or the shortest distance that can be detected with reliability		
<b>Digital Output</b>	NPN or PNP transistor open collector, 100mA, 30V DC (maximum); Residual: 1.5V (NPN), 2.5V (PNP)		
<b>Alarm Output</b>	NPN or PNP transistor open collector, 100mA, 30V DC (maximum); Residual: 1.5V (NPN), 2.5V (PNP)		
<b>Level Meter</b>	A or B mode: Represents analog output level on an 8-dot LED display, corresponding to object distance		
<b>Out LED</b>	On: When digital output is on (red LED)		
<b>Power LED</b>	On: When power is on (red LED)		
<b>Alarm LED</b>	On: When environment change occurs (red LED)		
<b>Stable LED</b>	On: When stable operation is ensured (green LED)		
<b>Response: Normal Mode</b>	Analog: 12Hz Digital (A mode): 22Hz Digital (B mode): 15Hz	Analog: 8Hz Digital (A mode): 15Hz Digital (B mode): 10Hz	Analog: 5Hz Digital (A mode): 10Hz Digital (B mode): 7Hz
<b>Response: Fuzzy Mode</b>	Analog/Digital: 4Hz	Analog/Digital: 3Hz	Analog/Digital: 2Hz
<b>Response: Hold Mode</b>	Analog/Digital: 4Hz	Analog/Digital: 3Hz	Analog/Digital: 2Hz
<b>Response Time</b>	Analog: 48ms Digital (A mode): 16ms Digital (B mode): 24ms	Analog: 70ms Digital (A mode): 24ms Digital (B mode): 36ms	Analog: 90ms Digital (A mode): 30ms Digital (B mode): 45ms
<b>Internal Synchronous Mode</b>	Two sensors synchronized, alternate oscillations prevent interference; response time is doubled		
<b>External Synchronous Mode</b>	Three or more sensors synchronized with timing pulse signal:		
	On/Off (A mode) ≥ 15ms On/Off (B mode) ≥ 20ms	On/Off (A mode) ≥ 20ms On/Off (B mode) ≥ 30ms	On/Off (A mode) ≥ 30ms On/Off (B mode) ≥ 45ms
<b>Oscillation Frequency</b>	Approximately 290kHz	Approximately 200kHz	Approximately 130kHz
<b>Directivity</b>	± 10° (half wave: -6 dB)	± 7° (half wave: -6 dB)	± 7° (half wave: -6 dB)
<b>Temperature Characteristics</b>	± 0.06% per °C (± 12 μA per °C)		
<b>Hysteresis</b>	0.24" (6mm)	0.39" (10mm)	0.79" (20mm)

Defined as the difference between the operating point and the release point  
This document provided by Barr-Thorp Electric Co., Inc. 800-473-9123 www.barr-thorp.com

**Dimensions**

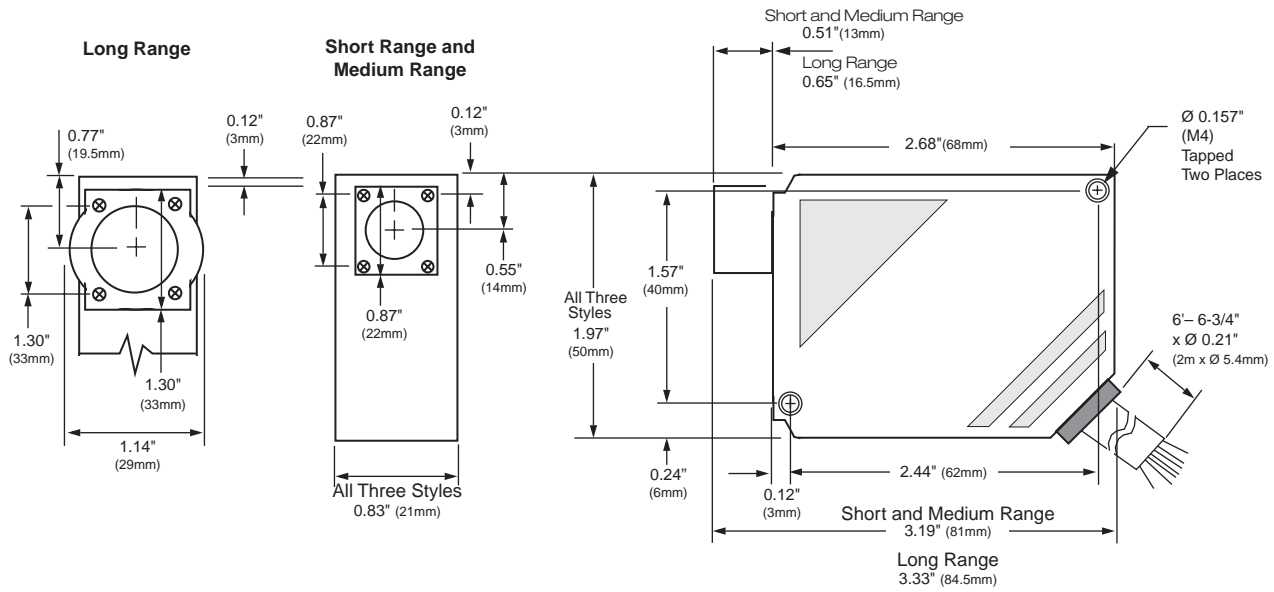

## General Information

### Specifications

Do not operate a sensor under any conditions exceeding these specifications.

Do not operate a sensor under current and voltage conditions other than those for which the individual sensor is rated.

Do not exceed the recommended operating temperature and humidity. Although sensors are rated for operation below 0°C, this specification does not imply that performance characteristics will remain constant under prolonged freezing conditions. Continued exposure and the accompanying frost, ice, dew, and condensation which accumulate on the optical surface will adversely affect sensor performance.

To maintain superior performance characteristics, do not exceed vibration and shock resistance ratings while operating a sensor. In addition, avoid isolated impacts to the sensor housing which are severe enough to adversely affect the waterproof characteristics.

### IEC (International Electrotechnical Commission) Ratings

Sensors rated IP67 are resistant to moisture when occasionally immersed in still water. Sensors rated IP64 through IP66 are resistant to moisture when occasionally subjected to splashing or when located in the vicinity of turbulent waters. These ratings do not imply that a sensor is intended for use under continual high-pressure water spray. Avoid such applications to maintain optimal sensor performance.

Sensors rated IP64 through IP67 are dust-tight and water-tight. For best performance, avoid using any sensor in an area where it will be subjected to heavy particle blasts and where dust, water, or steam will accumulate on the optical surface.

### Start-up

Do not test the housing for dielectric strength and insulation resistance, since the housing is connected to the electronic circuit ground of a sensor. Do not perform dielectric strength and insulation resistance tests on electrical systems without disconnecting photoelectric sensors, as such testing may result in damage to the sensor.

Several lines of sensors, as noted in the individual *operation* sections, are provided with an internal circuit to turn an output off for a specified amount of time upon power-up. This delay is normal; it prevents a transient state when turning power on.

### Optimum Performance

The optical surface of each sensor must be cleaned on a regular basis for continual superior performance. Use a soft cloth dipped in isopropyl alcohol to remove dust and moisture build-up.

**IMPORTANT:** Do not use organic solvents (such as thinner, ammonia, caustic soda, or benzene) to clean any part of a sensor.

All sensors experience signal inconsistencies under the influence of inductive noise. Do not use sensors in close proximity to transformers, large inductive motors, or generators. Avoid using sensors in direct contact with sources of excessive heat. Also avoid operation in close proximity to welding equipment.



1. Even though the SA6A ultrasonic sensor features protection against noise, there may be adverse effects from strong noise.
2. It is strongly recommended to avoid using any sensor where it will be continually subjected to elements which impair performance or cause corrosive damage to the sensor. In particular, avoid strong vibrations and shocks, corrosive gases, oils, and chemicals, as well as blasts of water, steam, dust, or other particles.

This document provided by Barr-Thorp Electric Co., Inc. 800-473-9123 www.barr-thorp.com

### Extraneous Light

Bright, extraneous light such as sunlight, incandescent lights, or fluorescent lights may impair the performance of sensors in detecting color or light.



3. SA6A ultrasonic sensors are not affected by extraneous light.

Make sure that extraneous light does not exceed recommended levels found in the individual *specifications* sections. When 500 lux is specified, this is equal to 50 footcandles. The average factory illumination is ordinarily below this level, except in areas where visual inspection is being performed. Only in such brightly lit areas is incident light of particular concern.

Unwanted light interference can often be avoided simply by making sure that the optical receiver is not aimed directly toward a strong light source. When mounting direction cannot be adjusted, place a light barrier between all nearby light sources and the receiver.

### Reflected-Light Sensors

When installing sensors which detect reflected light, make sure that unwanted light reflections from nearby surfaces, such as the floor, walls, reflective machinery, or stainless steel, do not reach the optical receiver.

Also, make sure that reflected-light sensors mounted in close proximity do not cause interfering reflections. When it is not possible to maintain the recommended clearance between sensors, as noted in the individual *installation* sections, provide light barriers between sensors.

### Through-Beam Sensors

A slit attachment is available to modify the beam size of through-beam sensors. This option is recommended for detecting very small objects (near the size of the smallest object which a sensor can detect) or for eliminating light interference when sensors are mounted in close proximity.

### Laser Sensors

**IMPORTANT:** Always consider safety when installing a laser sensor of any kind. Make sure that the laser beam cannot inadvertently shine into the eyes of people passing by or working in the vicinity. See safety information on page Q-20.

### Mounting

The mounting bracket and hardware are included with sensors, where applicable. Use the appropriate hardware for mounting, along with washers and spring washers or lock nuts. Do not overtighten attachment hardware. Overtightening causes damage to the housing and will adversely affect the waterproof characteristics of the sensor.

Best results can be obtained when the sensor is mounted so that the object sensed is in the center of the beam, rather than when the object is located near the edges of the sensing window. In addition, the most reliable sensing occurs when the majority of the objects being sensed are well within the sensing range, rather than at the extreme near and far limits.

**Wiring**

Avoid running high-voltages or power lines in the same conduit with sensor signal lines. This prevents inaccurate results or damage from induced noise. Use a separate conduit when the influence of power lines or electromagnetic equipment may occur, particularly when the distance of the wiring is extended.

**IMPORTANT:** Connect the sensor cables and wires as noted in the individual *Wiring* sections. Failure to connect as shown in wiring diagrams will result in damage to the internal circuit.

When extending sensor cables and wires, make sure to use cables equal or superior to that recommended in the individual *specifications* sections.

When wiring terminals, be sure to prevent contact between adjoining terminals. When using ring or fork lug terminals, use the insulated sleeve style only. Each sensor terminal can accept only one ring of fork lug terminal.

On ISF series photoelectric sensors, use recommended cable, along with the attached packing gland and washer, when wiring the terminals. This ensures waterproof and dustproof characteristics.

**Power Supply**

Noise resistance characteristics are improved when a sensor is grounded to the 0V power terminal. If the 0V power terminal is not at ground potential, use a ceramic 0.01µF capacitor which can withstand 250V AC minimum.

When using a switching power supply, be sure to ground the FG terminal to eliminate high-frequency noise. The power supply should include an insulating transformer, not an autotransformer.

On ISF series photoelectric sensors, the power supply should be sized according to the voltage drop through the lead wire when using a long extension for the DC type (328' or 100m maximum extension).

**Power Supply**

The compact PS5R-A power supply is the perfect companion item for most IDEC sensors. This power supply is only 1.77" (45mm) wide, 3.15" (80mm) tall, and 2.76" (70mm) deep. Call an IDEC representative for more details.

Part Number	Output Ratings
PS5R-A12	12V DC, 0.62A
PS5R-A24	24V DC, 0.32A

**Miscellaneous**

Strong magnetic fields may detract from the accuracy of the sensing measurement. Avoid mounting a sensor directly to machinery, since the housing is connected to the electronic circuit ground of the sensor. If it is necessary to mount a sensor on machinery, use the insulating plate and sleeve provided.

**Glossary**

**Attenuation:** Reduction of beam intensity as a result of environmental factors such as dust, humidity, steam, etc.

**Dark on:** Output energized when light is *not* detected by the receiving element. For through-beam sensors, light from the projector is not detected by the receiver when an object is present. For reflected light sensors, light is not detected when it is not reflected from an object surface.

**Diffuse-reflected light sensors:** Sensors that detect all scattered, reflected light. Light reflected from nearby surfaces, as well as intended object surface, is detected. Diffuse-reflected light sensors are often called "proximity switches," since they switch when any object is near. Also use to detect color contrast when colors reflect light intensity differently (green LED recommended for this application).

**EEPROM:** Acronym which stands for electronically erasable, programmable, read only memory.

**Excess gain:** Ratio of optical power available at a given projector-to-receiver range divided by the minimum optical power required to trigger the receiver.

**Extraneous light:** Incident light received by a sensor, unrelated to the presence or absence of object being detected. Extraneous light is usually unwanted background light such as sunlight and incandescent lamps in close proximity.

**ΔE:** The measurement of color difference as a three-variable function, located on an XYZ axis of light, hue, and chroma values.

**Hysteresis:** Operating point and release point at different levels. For solid state sensors, this is accomplished electrically. For mechanical switches, it results from storing potential energy before the transition occurs.

**Light on:** Output energized when light is detected by receiving element. For through-beam sensors, light from the projector is detected by the receiver when an object is not present. For reflected light sensors, light is detected when it is reflected from an object surface.

**Linearity:** Measurement of how nearly linear, that is, how accurate actual analog output is, with respect to distance.

**NPN/PNP:** Types of open collector transistors. NPN is a sink transistor; output on establishes negative potential difference. PNP is a source transistor; output on establishes positive potential difference.

**Polarizing:** Filtering out all reflected light except that which is projected in one plane only. Polarized retro-reflected light sensors detect the light from corner-cube type reflectors when an object is not present.

**Reflected-light sensors:** Sensors with the projector and receiver in one housing. Light is projected by the light source, and reflected light is received by the optical surface. Includes diffuse-reflected, retro-reflected, limited-reflected, and spot-reflected sensors.

**Repeatability:** Ability of a sensor to reproduce output readings consistently when the same value is applied consecutively, in the same direction, for a specified number of cycles, or for a specified time duration.

**Resolution:** Overall dimension of the smallest object which can be detected (when sensing the presence of an object) or smallest increment of distance which can be distinguished with reliable results (when sensing the position of an object).

**Response time:** Time elapsed between input and output. Total response time is the sum of object detection, amplifier response, and output response times.

**Retro-reflective scan:** This type of reflected light sensor uses a special reflector to return projected light when an object is not present. Sensor detects the presence of an object when the light is reflected differently.

**Through-beam sensors:** Sensors with a separate projector and receiver. The light source from the projector is detected by the receiver, except when an object is present.

**Transient:** Undesirable surge of current (many times larger than normal current) for a very short period, such as during the start-up of an inductive motor.

