

ALTIVAR® 18 AC Drives

File 8805



CATALOG CONTENTS

Description	Page
Introduction	1
Specifications	2-3
Torque Characteristics	4
Drive Catalog Numbers	5
PC Connection Options	5
Dynamic Braking Resistors	6
Inductors	7
Dimensions	8-9
Wiring Diagrams	10
Recommended Fuses	11
Electromagnetic Compatibility	12-13
Functions and Applications	14-15
Factory Settings	16
Adjustment and Extension of Functions	16
Drive Settings	16-23





Introduction

The ALTIVAR 18 drive for 3-phase asynchronous squirrel cage motors incorporates the latest technological developments.

Robust and compact, and conforming to international standards, the ALTIVAR 18 drive is a universal product. Created from our experience over several generations of drives, its functions meet the requirements of most applications including:

- Ventilation and air conditioning
- Pumps and compressors
- Horizontal material handling
- Packing and packaging

Factory Preset Values and Extension of Functions

The ALTIVAR 18 drive is ready to use right out of the box for the majority of applications. Its new algorithms for sensorless flux vector control and auto-tuning ensure optimum operation on standard motors worldwide.

An integrated keypad is used to modify parameter settings to suit your application. Two hierarchical levels of access ease parameter configuration:

- Level 1: Adjustments
- Level 2: Extension of functions

It is always possible to restore parameters to their factory preset values.

Electromagnetic Compatibility (EMC)

The ALTIVAR 18 drive has built-in filters eliminating the need for additional expense. The incorporation of filters in the drive simplifies installation and reduces the cost of conformity for CE marking. The filters conform to EN 61800-3/IEC 1800-3, domestic and industrial environments.

Functions

The main functions of the ALTIVAR 18 drive are:

- Starting/stopping and speed control
- Dynamic braking and braking to standstill
- Energy savings
- PI feedback (flow rate, pressure, etc.)
- Protection of motor and drive
- Preset speeds
- Jog
- Automatic catching a spinning load with speed search (flying restart)
- Automatic limiting of operating time at low speed

The RS232C standard PC Connection option is used for configuration and adjustment using a personal computer. It allows you to:

- Prepare a configuration in the design office without connecting the drive
- Back up settings on diskette or hard disk
- Load settings to the drive remotely
- Print out settings on paper



ALTIVAR 18 AC Drives Specifications

Environment

Conformity to standards		<p>ALTIVAR 18 drives have been developed to conform to the most stringent national and international standards and recommendations for electrical industrial devices (IEC, EN, NFC, VDE) including:</p> <ul style="list-style-type: none"> • Low voltage EN 50178 • EMC immunity: <ul style="list-style-type: none"> — IEC 1000-4-2/EN 61000-4-2 level 3 — IEC 1000-4-3/EN 61000-4-3 level 3 — IEC 1000-4-4/EN 61000-4-4 level 3 — IEC 1000-4-5/EN 61000-4-5 level 3 — IEC 1800-3/EN 61800-3, environments 1 and 2 • EMC, conducted and radiated emissions: <ul style="list-style-type: none"> — IEC 1800-3/EN 61800-3, environments 1 (public sector) and 2 (industrial sector) under restricted distribution — EN 55011 class A (radio interference suppression filters included)
CE marking		The ALTIVAR 18 drive was developed in accordance with European (73/23/EEC and 93/68/EEC) and EMC (89/336/EEC) low voltage directives. For this reason, ALTIVAR 18 drives have been given the CE mark from the European community.
Product certification		UL and CSA
Degree of protection		NEMA Open IP31: with grey tape, sizes up through ATV18U72 (5 hp) IP21: with grey tape, sizes ATV18U90 (7.5 hp) and above IP20: without the grey tape on the top of the drive
Resistance to vibrations	g	0.6 from 10 to 50 Hz 2 from 50 to 150 Hz
Pollution degree		Degree 2 according to NEMA ICS-1 and IEC 664. The drive must be protected against dust, corrosive gas, and falling liquid.
Maximum relative humidity		95% non-condensing and without dripping. Provide heating system if there is condensation.
Maximum ambient temperature		
Storage	°F (°C)	-13 to +149 (-25 to +65)
Operation	°F (°C)	+40 to +104 (-10 to +40) with grey tape on top of the drive +40 to +122 (-10 to +50) without grey tape on top of the drive
Altitude	ft (m)	3300 (1000) without derating For each additional 3300 ft (1000 m), derate the current by 3%.
Operating position		Vertical

Electrical Characteristics

Power supply		
Voltage	V	200 - 15% to 240 + 10% single-phase 200 - 15% to 230 + 10% 3-phase 380 - 15% to 460 + 10% 3-phase
Frequency	Hz	50/60 ±5%
Output voltage	V	Maximum output line voltage is equal to input line voltage.
Output frequency range	Hz	0.5 to 320



Electrical Characteristics (cont.)	
Maximum transient current	150% of nominal drive current for 60 s
Transient overtorque	150% of nominal motor torque
Braking torque	30% of the nominal motor torque without braking resistor (typical value) Up to 150% with optional braking resistor
Available control voltage	+10 V - 0%, + 15% for the manual speed potentiometer (1 k Ω to 10 k Ω), maximum output current = 10 mA +24 V for control inputs, maximum output current = 100 mA
Analog inputs AI	1 voltage analog input AI1: 0 to +10 V, impedance = 30 k Ω 1 voltage analog input AI2: 0 to +10 V, impedance = 30.55 k Ω 1 current analog input AIC: 0-20 mA or 4-20 mA, impedance = 400 Ω AI2 and AIC cannot be used at the same time.
Frequency resolution	Display units: 0.1 Hz Analog inputs: 0.1 Hz for 100 Hz maximum
Time constant when changing a setpoint	ms 5
Logic inputs LI	4 logic inputs with an impedance of 3.5 k Ω , isolated. 3 can be reassigned. Power supply: +24 V (maximum 30 V), state 0 if < 5 V, state 1 if > 11 V
Logic output LO	1 PLC-compatible logic output (open collector). Can be assigned. +24 V (19.2 to 30 V), maximum 20 mA with internal source or 200 mA with external source
Acceleration and deceleration ramps	Linear ramps which can be adjusted separately from 0.1 to 3,600 seconds (0.1 s definition) Automatic adaptation of the ramp times if the torque capacity is exceeded Deceleration ramp adaptation can be inhibited
Voltage/frequency ratio	Factory set for most constant torque applications with sensorless flux vector control. Adjustment possible: specific ratios for pumps and fans, energy savings, and constant torque V/f for special motors.
Frequency loop gain	Factory set for the majority of applications. Adjustment possible for machines with high resistive torque or high inertia, or for machines with fast cycles.
Slip compensation	Automatic regardless of the load Can be disabled or adjusted
Switching frequency	Factory set for 4 kHz. Can be adjusted from 2.2 to 12 kHz.
Braking to standstill	DC injection: <ul style="list-style-type: none"> • By a contact to an assigned logic input • Automatically as soon as the deceleration frequency becomes < 0.5 Hz for a time adjustable between 0 to 25 seconds
Drive protection	Electrical isolation between power and control circuits (inputs, outputs, supplies) Protection against short circuits: <ul style="list-style-type: none"> • In internal power supplies • Between output phases Thermal protection against excessive overheating and overcurrents Protection against input line supply under/overvoltage Protection against overvoltage during braking
Motor protection	Thermal protection integrated in the drive by calculation of I ² t
Fault relay	NO/NC contact Minimum switching capacity: 10 mA at 5 Vdc Maximum switching capacity: <ul style="list-style-type: none"> • For inductive load: 1.5 A at 250 Vac or 1.5 A at 30 Vdc • Protect relay contacts with Class CC time delay fuses; Maximum rating, 2 A
Display	1 red LED on the front panel: LED on indicates that the drive is powered up Coded display via 4-character, 7-segment keypad display



Torque Characteristics

The following graph defines the continuous and transient overtorque available with a self-ventilated or force-ventilated motor. The only difference between the two is the ability of the motor to provide a high continuous torque at less than half nominal speed.

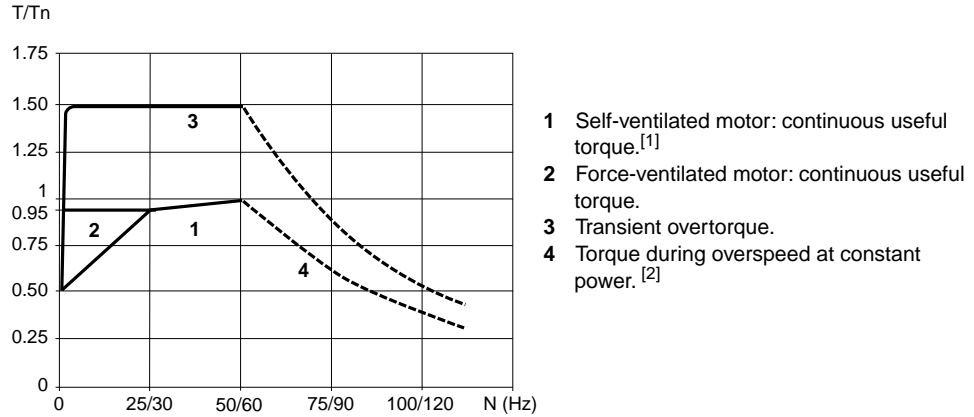

[1] For fractional motors $\leq 1/3$ hp (250 W), derating is less (20% instead of 50% at the lowest frequency).
 [2] The nominal motor frequency and the maximum output frequency can be adjusted from 40 to 320 Hz.
 Caution: consult motor manufacturer before operating motor above rated speed.

Use with a Motor of Different Power

The drive can supply any motor with power less than that for which it is designed. For motor powers slightly greater than the drive rating, ensure that the motor current does not exceed the continuous drive output current (see page 5 for ratings).

Connecting Motors in Parallel

Drive rated power must be greater than or equal to the sum of the powers of the motors connected to the drive. When connecting motors in parallel, it is necessary to provide separate overload protection by thermal sensor or relay. If three or more motors are used in parallel, a three-phase inductor installed between the drive and motor is recommended.

Connecting an Additional Motor Downstream from the Drive

A motor can be connected downstream while the drive is running if the power of the motor is less than that of the drive, and if the overload is acceptable (peak current is less than or equal to the maximum transient drive current).



Drive Catalog Numbers

ALTIVAR 18 drives for asynchronous motors from 0.5 to 20 hp (0.37 to 15 kW)



ATV18U09M2



ATV18U72N4

Supply		Motor		ALTIVAR 18				Catalog Number [3]	Weight
Input Voltage	Line Current [1]	Rated Power [2]		Continuous Output Current	Max. Transient Current (60 s)	Power Dissipated at Nominal Load			
V1 to V2	at V1	at V2	kW	HP	A	A	W	lb (kg)	
200 to 240 50/60 Hz single-phase	4.4	3.9	0.37	0.5	2.1	3.2	23	ATV18U09M2	2.3 (1.5)
	7.6	6.8	0.75	1	3.6	5.4	39	ATV18U18M2	3.3 (1.5)
	13.9	12.4	1.5	2	6.8	10.2	60	ATV18U29M2	4.6 (2.1)
	19.4	17.4	2.2	3	9.6	14.4	78	ATV18U41M2	6.2 (2.8)
200 to 230 50/60 Hz 3-phase	16.2	14.9	3	—	12.3	18.5	104	ATV18U54M2 [5]	7.3 (3.3)
	20.4	18.8	4	5	16.4 [4]	24.6	141	ATV18U72M2 [5]	7.3 (3.3)
	28.7	26.5	5.5	7.5	22 [4]	33	200	ATV18U90M2 [5]	17.2 (7.8)
	38.4	35.3	7.5	10	28 [4]	42	264	ATV18D12M2 [5]	17.2 (7.8)
380 to 460 50/60 Hz 3-phase	2.9	2.7	0.75	1	2.1 [4]	3.2	24	ATV18U18N4	4.4 (2.0)
	5.1	4.8	1.5	2	3.7 [4]	5.6	34	ATV18U29N4	4.6 (2.1)
	6.8	6.3	2.2	3	5.3 [4]	8	49	ATV18U41N4	6.8 (3.1)
	9.8	8.4	3	—	7.1 [4]	10.7	69	ATV18U54N4	7.3 (3.3)
	12.5	10.9	4	5	9.2 [4]	13.8	94	ATV18U72N4	7.3 (3.3)
	16.9	15.3	5.5	7.5	11.8 [4]	17.7	135	ATV18U90N4	17.6 (8.0)
	21.5	19.4	7.5	10	16 [4]	24	175	ATV18D12N4	17.6 (8.0)
	31.8	28.7	11	15	22 [4]	33	261	ATV18D16N4	26.4 (12.0)
42.9	38.6	15	20	29.3 [4]	44	342	ATV18D23N4	26.4 (12.0)	

[1] Typical value without additional inductance.
 [2] These power values are given for a switching frequency of 4 kHz.
 [3] This number indicates a drive without a user's manual. To receive a United States user's manual, add the letter "U" at the end of the catalog number.
 [4] Values shown are for operation of switching frequencies from 2.2 kHz to 4 kHz. Derate currents by 5% for operation up to 8 kHz, and derate by 10% for operation above 8 kHz.
 [5] Available second quarter of 1997.

PC Connection Options

for ALTIVAR 18 drives all ratings

Description	Catalog Number	Weight lb (kg)
RS232C PC Connection Option with Software [6]	VW3A18104 [7]	1.1 (0.5)
3-1/2" Diskettes (Software Only)	VW3A18105 [7]	0.2 (0.1)

[6] Kit contains: One 16.4 ft (5 m) connection cable for the PC; One 11.48 ft (3.5 m) connection cable for the drive; One adaptation module; 3-1/2" diskettes containing the software.
 [7] Available third quarter of 1997.



ALTIVAR 18 AC Drives

Dynamic Braking Resistors

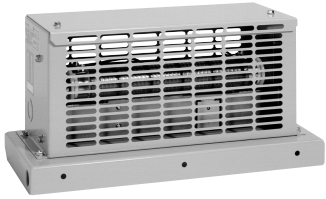

Dynamic Braking Resistors

Introduction

Dynamic braking resistors allow the ALTIVAR 18 drive to operate in quadrants 2 and 4 of the torque-speed curve by displacing braking energy.

The resistors are provided in a Type 1 enclosure and are thermally protected.

Applications include machines with high inertia, overhauling loads, and machines with fast cycles.

Characteristics

Resistors	VW3A66711 to 714
Ambient temperature	104 °F (40 °C)
Degree of protection	Type 1
Load factor of resistors	Resistors are rated for stopping six times rotor inertia of a four-pole motor with the drive at current limit.
Load factor of drives	The internal circuits of the drives which ensure braking on external resistors are sized for the following cycles. If these values are exceeded, the drive trips and displays an error.
ATV18U09M2	1.5 Tn for 8 seconds per minute Tn for 12 seconds per minute 0.6 Tn for 20 seconds per minute
ATV18U18M2	1.5 Tn for 4 seconds per minute Tn for 6 seconds per minute 0.6 Tn for 10 seconds per minute
ATV18U29M2	1.3 Tn for 2 seconds per minute Tn for 3 seconds per minute 0.6 Tn for 5 seconds per minute
Other drives	1.5 Tn for 60 seconds per cycle of 140 seconds Tn continuously

Catalog Numbers

For Drives	Ohmic Value Ω	Power W	Catalog Number	Weight lb (kg)
ATV18U09M2, U18M2, U18N4, U29N4, U41N4, U54N4	120	120	VW3A66711	2.54 (1.15)
ATV18U29M2, U72N4, U90N4, D12N4	56	118	VW3A66712	3.31 (1.50)
ATV18U41M2, U54M2, U72M2, D16N4, D23N4	28	204	VW3A66713	3.31 (1.50)
ATV18U90M2, D12M2	14	202	VW3A66714	3.31 (1.50)



Inductors

Introduction

Inductors provide improved protection against overvoltages on the input supply and reduce harmonic distortion of the current produced by the drive.

The inductors recommended are open style, 5% impedance rated line inductors from MTE Corporation. Equivalent inductors from another manufacturer may be used.

The use of inductors is recommended in the following cases:

- Input supply with significant interference from other equipment
- Input supply with a voltage imbalance between phases > 1.8% of the nominal voltage
- Drive supplied by a line with low impedance (close to transformers ten times more powerful than the drive)
- Large number of drives installed on the same supply

Catalog Numbers

For Drives	Characteristics	Catalog Number ^[1]	Weight lb (kg)
ATV18U09M2	6.0 mH - 4 A	RL-00401 ^[2]	4 (1.8)
ATV18U18M2	3.0 mH - 8 A	RL-00801 ^[2]	7 (3.1)
ATV18U29M2	1.6 mH - 18 A	RL-01801 ^[2]	9 (4.0)
ATV18U41M2	1.0 mH - 25 A	RL-02501 ^[2]	11 (5.0)
ATV18U54M2, U72M2	1.5 mH - 18 A	RL-01802	12 (5.4)
ATV18U90M2	1.2 mH - 25 A	RL-02502	14 (6.3)
ATV18D12M2	0.8 mH - 35 A	RL-03502	16 (7.3)
ATV18U18N4	20.0 mH - 2 A	RL-00202	4 (1.8)
ATV18U29N4, U41N4	9.0 mH - 4 A	RL-00403	5 (1.8)
ATV18U54N4, U72N4	5.0 mH - 8 A	RL-00803	11 (5.0)
ATV18U90N4	4.2 mH - 12 A	RL-01203	18 (8.1)
ATV18D12N4	2.5 mH - 18 A	RL-01803	16 (7.3)
ATV18D16N4	2.0 mH - 25 A	RL-02503	18 (8.1)
ATV18D23N4	1.2 mH - 35 A	RL-03503	30 (14.0)

^[1] Inductors can be ordered from Square D's Columbia S.C. plant for drop shipment to customer.

^[2] Inductors listed are 3-phase devices where the drive input is single-phase.

When using these Inductors, connect the single phase power to the outside windings



ALTIVAR 18 AC Drives

Dimensions

Dimensions

ALTIVAR 18 Drive

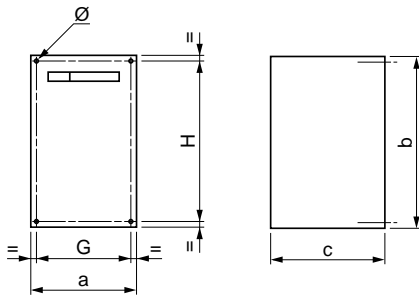

Dimensions:
in (mm)

ATV18****	a	b	c	G	H	Ø
U90M2, U18M2	4.41 (112)	7.17 (182)	4.76 (121)	3.94 (100)	6.7 (170)	0.20 (5)
U29M2, U18N4, U29N4	5.87 (149)	7.24 (184)	6.18 (157)	5.39 (137)	6.77 (172)	0.20 (5)
U41M2, U54M2, U72M2, U41N4, U54N4, U72N4	7.28 (185)	8.46 (215)	6.22 (158)	6.73 (171)	7.95 (202)	0.24 (6)
U90M2, D12M2, U90N4, D12N4	8.27 (210)	11.81 (300)	6.69 (170)	7.48 (190)	11.02 (280)	0.28 (7)
D16N4, D23N4	9.65 (245)	15.35 (390)	7.48 (190)	8.86 (225)	14.57 (370)	0.40 (10)

Installation Precautions

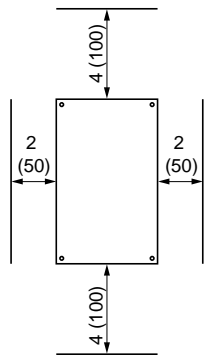

For all ALTIVAR 18 drives:

- When installing drive, allow the minimum clearances shown.
- Install the drive in a vertical position.
- Do not place the drive close to or directly above heat radiating elements.
- Leave enough space to ensure air circulation necessary for cooling. Ventilation is from the bottom to the top of the drive.

Flow Rate of Integrated Fan

ATV18*****	Flow:	
	CFM	m ³ /minute
U09M2, U18M2, U18N4	Non-ventilated	
U29M2, U29N4	8.8	0.25
U41M2, U54M2, U72M2, U41N4, U54N4, U72N4	26.5	0.75
U90M2, D12M2, U90N4, D12N4, D16N4, D23N4	45.9	1.3

PC Connection Option

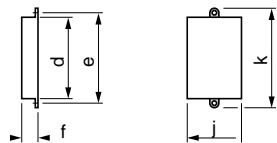

	d	e	f	j	k
VW3A18104	3.5 (90)	3.9 (100)	0.71 (18)	2.4 (60)	4.3 (110)



Dimensions (cont.)

Dynamic Braking Resistors

VW3A66711 and VW3A66712

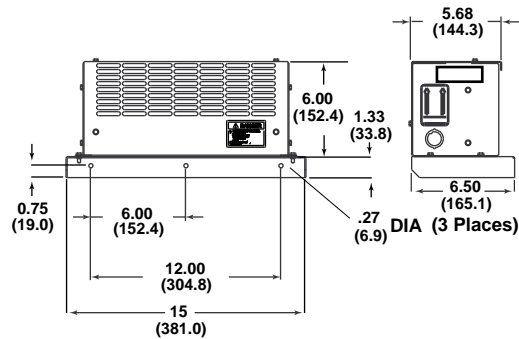

VW3A66713 and VW3A66714

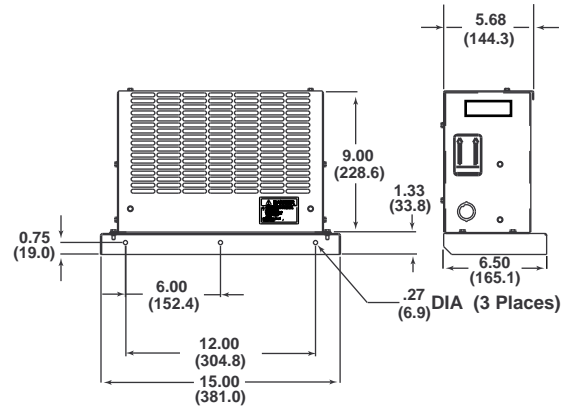

Inductors

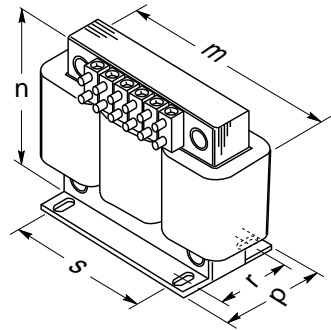

Dimensions:
in (mm)

Inductor	m	n	p	r	s
RL-00401	4.4 (112)	4.0 (102)	2.9 (74)	2.0 (50)	1.4 (36)
RL-00801	6.0 (152)	4.8 (122)	3.1 (79)	2.1 (54)	2.0 (50)
RL-01801	6.0 (152)	4.8 (122)	3.1 (79)	2.1 (54)	2.0 (50)
RL-01802	6.0 (152)	4.8 (122)	3.4 (86)	2.5 (53)	2.0 (50)
RL-02501	7.2 (183)	5.6 (142)	3.4 (86)	2.3 (60)	3.0 (76)
RL-02502	7.2 (183)	5.6 (142)	3.4 (86)	2.3 (60)	3.0 (76)
RL-03502	7.2 (183)	5.7 (145)	3.8 (97)	2.6 (66)	3.0 (76)
RL-00202	4.4 (112)	4.0 (102)	2.9 (74)	2.0 (50)	1.44 (36)
RL-00403	4.4 (112)	4.0 (102)	3.1 (79)	2.1 (54)	1.44 (36)
RL-00803	6.0 (152)	4.8 (122)	3.4 (86)	2.5 (63)	2.0 (50)
RL-01203	6.0 (152)	4.8 (122)	3.7 (94)	2.75 (70)	2.0 (50)
RL-01803	7.2 (183)	5.7 (145)	3.8 (97)	2.6 (86)	3.0 (76)
RL-02503	7.2 (183)	5.7 (145)	3.8 (97)	2.6 (86)	3.0 (76)
RL-03503	9.0 (229)	7.0 (178)	4.8 (122)	3.2 (80)	3.0 (76)



Wiring Diagrams

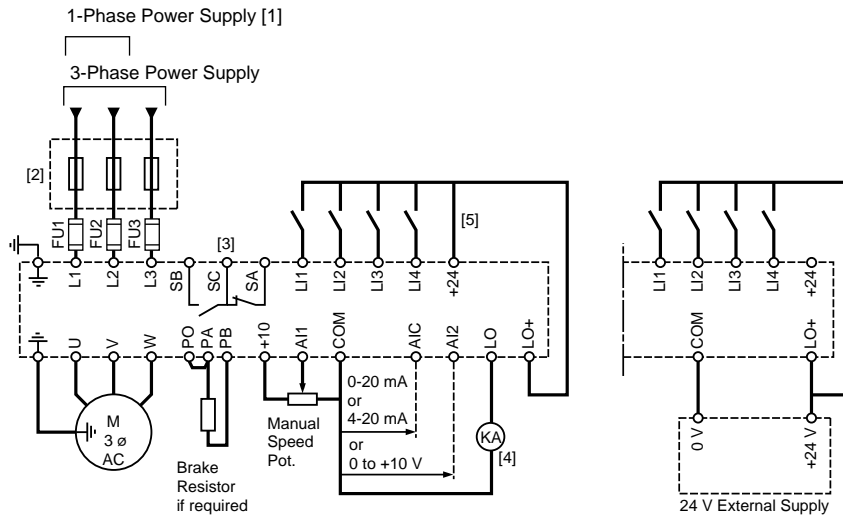

- [1] ATV18U09M2 to U41M2 only.
- [2] Line inductor if required (1-phase or 3-phase).
- [3] Fault relay contacts for remote signalling of the drive controller state. Contact state shown with drive controller deenergized or faulted.
- [4] Relay must draw ≤ 20 mA to be used on internal supply. For relay up to 200 mA, use external supply.
- [5] This jumper needed only if logic output is used. When using a +24 V external supply, connect the 0 V to the COM terminal, and connect LO+ to the external +24 V instead of the +24 V terminal on the drive controller.

External 24 V Supply

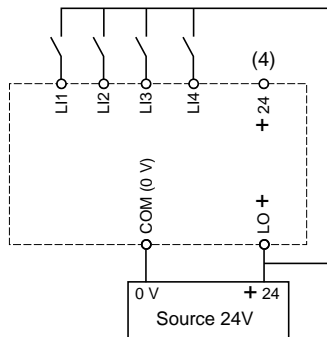

Note: All terminals are located at the bottom of the drive. Equip all inductive circuits near the drive (relays, contactors, solenoid valves) with noise suppressors or connect them to a separate circuit.



Recommended Fuses

Recommended Fuses for 230 V Drives

Motor		Drive Controller ATV18****	Fuses	
kW	HP		Class CC	Class J
0.37	0.5	U09M2	600 V, 6 A	600 V, 6 A
0.75	1	U18M2	600 V, 10 A	600 V, 10 A
1.5	2	U29M2	600 V, 20 A	600 V, 20 A
2.2	3	U41M2	600 V, 25 A	600 V, 25 A
3	—	U54M2	600 V, 25 A	600 V, 25 A
4	5	U72M2	—	600 V, 30 A
5.5	7.5	U90M2	—	600 V, 40 A
7.5	10	D12M2	—	600 V, 40 A

Recommended Fuses for 460 V Drives

Motor		Drive Controller ATV18	Fuses	
kW	HP		Class CC	Class J
0.75	1	U18N4	600 V, 5 A	600 V, 5 A
1.5	2	U29N4	600 V, 12 A	600 V, 12 A
2.2	3	U41N4	600 V, 10 A	600 V, 10 A
3	—	U54N4	600 V, 15 A	600 V, 15 A
4	5	U72N4	600 V, 20 A	600 V, 20 A
5.5	7.5	U90N4	600 V, 25 A	600 V, 25 A
7.5	10	D12N4	—	600 V, 40 A
11	15	D16N4	—	600 V, 40 A
15	20	D23N4	—	600 V, 60 A



Electromagnetic Compatibility

Installation Precautions

For electromagnetic compatibility, observe the following installation precautions:

- Ensure that the grounds of the drive, the motor, and the cable shields are at equal potential.
- Use shielded cables with the shields tied to ground at both ends of the motor cable and the control cables. The ground connection to the shield must make contact with the complete circumference of the shield. This shielding can be achieved by using metallic conduit as long as there is no discontinuity (bonding at conduit fittings is required).

Installation Plan

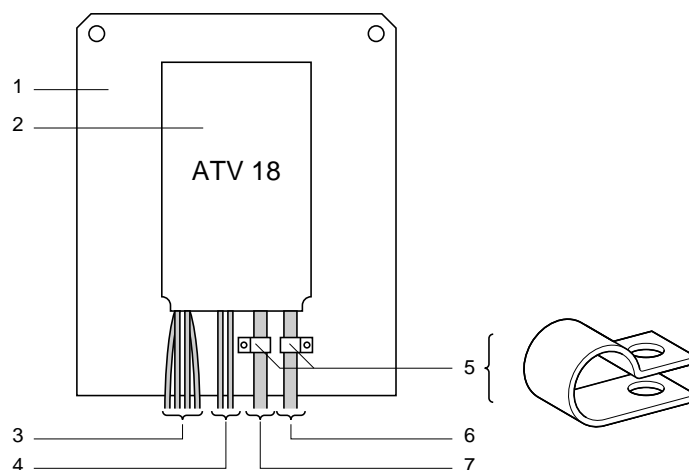

Electromagnetic Compatibility (cont.)

Refer to Installation Plan on page 12.

1. Unpainted sheet metal mounting plate with anti-corrosion conductive treatment (ground plane). Painted sheet metal can be used if a good electrical contact is made between the support and mounting surfaces and 2 and 5.
2. The drive is mounted directly to the metal plate. Ensure that all four corner mounting points have good electrical contact with the metal plate.
3. Non-shielded input wire or cable, connected to the input inductors, if used. Maintain separation between input wiring and motor wiring.
4. Non-shielded wire for the output of the fault relay contacts. Maintain separation between fault relay wiring and motor wiring.
5. The shields of cables 6 and 7 must be fastened and grounded as close to the drive as possible. The shields must be well clamped to the mounting plate. To ensure good contact:
 - Strip the shields.
 - Fasten stripped portions of the shields to the mounting plate with correctly sized clamps.
 - Use stainless steel clamps.
6. Shielded cable for connection to motor, with shield tied to ground at both ends. At the drive, the shield is connected to the E or G/E terminal on the far right of the power terminal strip. This shield must not be interrupted and if intermediate terminal blocks are used, they must be EMC-shielded metallic boxes. The cable shield must have an ampacity greater than or equal to the ampacity of the ground conductor.
7. Shielded cable for connection to control system. For applications requiring several conductors, a small wire size must be used (20 AWG or 0.5 mm²). The shield must be tied to ground at both ends. At the drive, the shield is connected to the E or G/E terminal on the far right of the power terminal strip. This shield must not be interrupted and if intermediate terminal blocks are used, they must be EMC-shielded metallic boxes. Maintain separation between control/command wiring and motor wiring.

Note: Connection at equal potential of the grounds between the drive, motor, and cable shields does not preclude the connection of equipment ground conductors as required by national and local codes.



ALTIVAR 18 AC Drives Functions and Applications

Applications

Pumps and Compressors

Fans

Centrifugal pumps
Screw compressors

Dryers, drying ovens, tunnels, extraction hoods
Air treatment

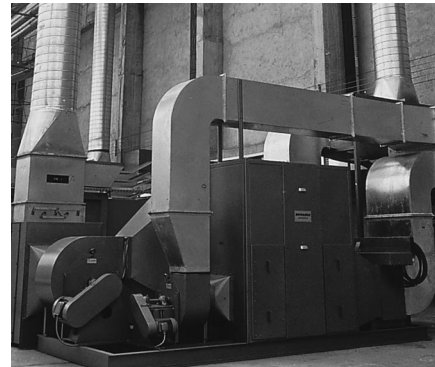
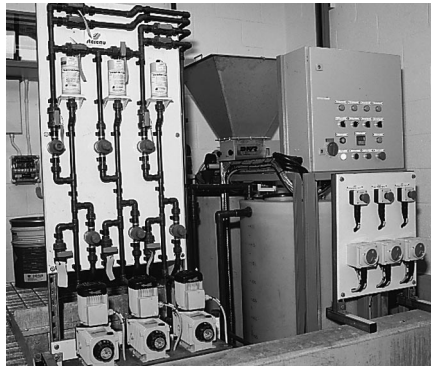

Basic functions

Maximum frequency 320 Hz	—	—
Choice of V/f ratio ^[1]	—	—
Variable torque	●	—
Sensorless flux vector control	—	—
Energy savings	—	●
Switching frequency	4 to 12 kHz	12 kHz
Automatic DC injection at stop	—	—
Dynamic braking	—	—
Auto-tuning	—	—
Skip frequency	●	●

Application and control system functions

Deceleration ramp adaptation	●	●
Automatic catching a spinning load	●	●
Automatic restart	●	●
Controlled stop at loss of power	—	—
Low speed run time	●	—
Analog inputs	—	—
Summing	—	—
PI regulator	●	●
Logic inputs	—	—
2 run directions	—	—
DC injection	—	●
Fast stop	—	—
Jog	—	—
Preset speeds	—	●
Logic outputs	—	—
Speed reference reached	●	●
Frequency threshold reached	●	—

^[1] Choice of V/f ratio: constant torque selection is used for motors connected in parallel and special motors (e.g., with resistive cage).



Material Handling

Continuous conveyors
belt, screw, chain

Cyclical conveyors
Transfer tables
Manipulation arms



Packing/Packaging

Hoop casing machines
Bagging machines
Labeling machines

Palletizers



Special Machines

Wood working
Textiles

Mixers
Kneaders

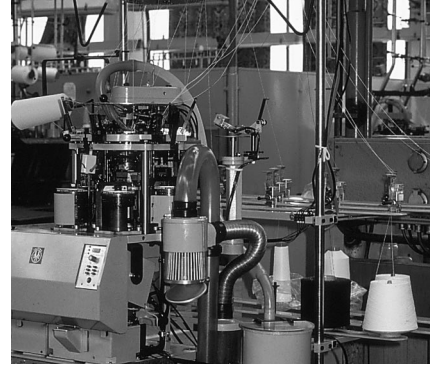

—	—	—	—	●	—
—	—	—	—	—	—
●	●	●	●	●	●
—	—	—	—	—	—
4 kHz	4 kHz	4 kHz	4 kHz	12 kHz	4 kHz
●	●	●	●	●	●
●	●	●	●	●	—
●	●	●	●	●	●
—	—	—	—	—	●
●	—	●	—	●	●
●	—	●	—	●	●
—	—	—	—	—	—
●	—	—	—	●	●
—	—	—	—	—	—
●	●	●	●	●	●
—	—	—	—	—	●
●	—	—	—	●	—
●	●	●	●	●	●
●	●	●	●	●	●
—	—	—	—	—	—
●	—	—	—	●	●
—	—	●	●	—	●



Factory Settings

The drive is supplied ready to use for most applications with the following functions and settings:

Motor base frequency	50 Hz
Motor voltage	230 V (ATV18***M2) or 400 V (ATV18***N4)
Acceleration and deceleration ramps	3 seconds
Low speed	0 Hz
High speed	50 Hz
Motor thermal current	nominal drive current
Injection braking current at stop	0.7 nominal drive current for 0.5 seconds
V/f ratio	Constant torque operation with sensorless flux vector control
Logic inputs	2 run directions (LI1, LI2) 4 preset speeds (LI3, LI4): 0 Hz, 5 Hz, 25 Hz, 50 Hz
Analog inputs	AI1: 0 to 10 V reference AI2 (0 to 10 V) or AIC (0 to 20 mA) summed with AI1
Logic output:	LO: speed reference attained
Deceleration ramp adaptation	Auto deceleration ramp adaptation in case of overvoltage when braking
Switching frequency	4 kHz

User Adjustment and Extension of Functions

The keypad can be used to modify the settings and extend the functions described on pages 16 to 22. There are two levels of access:

- Level 1: Adjustments (basic configuration)
- Level 2: Extension of functions

It is possible to restore the factory preset values at any time.

Acceleration and Deceleration

The linear acceleration and deceleration ramps can be adjusted separately from 0.1 to 3600 seconds. Factory setting is 3 seconds.

Operating Speed Range

The two frequency limits, HSP (high speed) and LSP (low speed), define the speed range permitted by the machine during operation. The frequency limits are suitable for all applications. Ensure that the HSP setting is suitable for the motor.

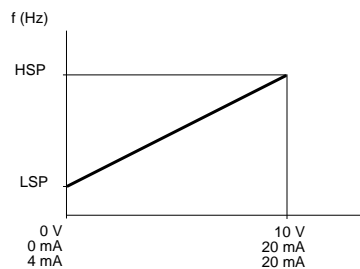

LSP: 0 to HSP, factory setting 0 Hz
HSP: LSP to 320 Hz, factory setting 50 Hz



Automatic Deceleration Ramp Adaptation

Function

Automatic adaptation of the deceleration ramp time if the initial setting is too low given the inertia of the load. This function eliminates tripping due to an overbraking fault.

Applications

All applications not requiring a controlled stop and not using dynamic braking.

Setting

Yes or no, factory set to yes. Automatic adaptation must be set to no if the machine has position control when stopping on a ramp, or dynamic braking.

Thermal Protection of the Motor

Function

Indirect protection of the motor by continuous calculation of I^2t . This function provides thermal protection of the motor in the following cases:

- Ambient temperature around the motor ≤ 40 °C
- Prolonged operation between 30 Hz and 50/60 hz with self-ventilated motor
- Below 30 Hz, reduced cooling of the motor is taken into account in the calculation

Ith: 0.5 to 1.15 times the continuous output current of the drive, factory set to drive output current. Set to the nominal current shown on the motor nameplate. To override thermal protection, increase the adjustment value to the maximum value.

If motors are connected in parallel on the same drive, a separate thermal relay should be added for each motor.

Thermal Protection of the Drive

Function

Indirect protection of the drive by calculation of I^2t . This function provides thermal protection of the drive for normal ambient temperature conditions. Typical tripping values are:

- Motor current = 185% of nominal drive current: 2 seconds
- Motor current = 150% of nominal drive current: 60 seconds
- Motor current = 110% of nominal drive current: not active

Protection by thermistor mounted on heat sink.

Fault Relay

The fault relay is energized when the drive is powered up and there is no fault present. There is a NO/NC contact available.

The drive is reset after a fault:

- By cycling power
- Automatically as described in "Automatic Restart" on page 22.

Logic Inputs

Assignment of the logic inputs:

- LI1: Forward operation
- LI2, LI3, LI4: The possible assignments are:
 - Reverse operation, factory assigned to LI2
 - Preset speeds: 2 or 4, factory set to 4 preset speeds with LI3 and LI4
 - Jog
 - Fast stop
 - DC injection



Preset Speeds

Function

Use of preset speeds.

Applications

Material handling and machines requiring 2 or 4 operating speeds.

- 2 speeds with LI3 or LI4
 - State 0: First preset speed = LSP + analog reference
 - State 1: Second preset speed = HSP
- 4 speeds with LI3 and LI4
 - LI3 = 0 and LI4 = 0: First preset speed = LSP + analog reference
 - LI3 = 1 and LI4 = 0: Second preset speed (adjustable from LSP to HSP)
 - LI3 = 0 and LI4 = 1: Third preset speed (adjustable from LSP to HSP)
 - LI3 = 1 and LI4 = 1: Fourth preset speed = HSP

Settings

Factory setting is 4 preset speeds with LI3 and LI4:

- First preset speed: LSP = 0 + analog reference
- Second preset speed: 5 Hz
- Third preset speed: 25 Hz
- Fourth preset speed: HSP = 50 Hz

Note: The preset speeds function is not compatible with the PI regulator function (see page 20).

Jog

Function

Jog function with a minimum ramp time of 0.1 second and a speed reference up to 10 Hz (factory preset to 10 Hz). Minimum time between two jog pulses is 0.5 seconds. Jog requires one logic input (LI1, LI2, or LI3) and a direction input (FW or RV).

Applications

- Machines which run in manual
- Used to move slightly forward when performing maintenance

Note: Jog is not compatible with PI regulator (page 20). During jog operation, automatic DC injection braking at stop is deactivated; however, DC injection braking using a logic input has priority over Jog.

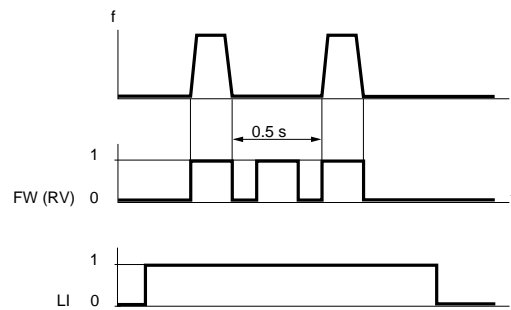

Fast Stop

Function

When activated, the drive will stop the motor on a deceleration ramp that is one-fourth the set deceleration adjustment. This time may be modified (lengthened) to prevent an overbraking fault. Requires 1 logic input (LI2, LI3, or LI4), activated when LI is off. Used for conveyors with electric brake (optimization of braking time depending on the load).

Note: During a fast stop, automatic DC injection braking and DC injection braking using a logic input are not active.

DC Injection Braking

Function

There are two modes of DC injection braking:

- DC injection braking automatic at stop (frequency < 0.5 Hz)
 - Automatic current at stop adjustable from 0.25 times the thermal motor current (I_{th}) to 1 times the continuous current of the drive. Factory setting is 0.7 nominal drive current
 - Braking time at stop: 0 to 25 seconds or continuous
- DC injection braking activated by logic input LI2, LI3, or LI4
 - Braking when LI is on
 - Fixed braking current: nominal drive current for 5 seconds followed by 0.5 I_{th}

Applications

Braking at low speed for high inertia fans and maintaining torque at stop (0.2 to 0.4 T_n) in the case of fans situated in an air flow.

Factory setting: automatic at stop only, 0.5 seconds.

Note: DC injection braking is not active if the fast stop function is in progress.

Logic Output

Assignment of logic output LO:

- Detection of speed attained: detection that speed reference has been attained by the motor, with a hysteresis of ± 2.5 Hz.
- Detection of a frequency level attained: Detection of a minimum level of frequency attained, with a hysteresis of 2 Hz. Level adjustable from LSP to HSP.

Factory setting: LO is assigned to detection of reference speed attained.

Analog Inputs: Speed Reference

Function

Two summing inputs (factory setting).

- 1 speed reference input: + 10 V (AI1)
- 1 additional analog input used: either voltage 0 to 10 V (AI2) or current 0 to 20 mA or 4 to 20 mA (AIC)

Applications

Machines in which the speed is determined by an external parameter.



Analog Inputs: PI Regulator

Function

Simple regulation of flow rate or pressure with a sensor sending a feedback signal adapted to the drive. AI1 is the reference, AI2 or AIC can be assigned to feedback. For pump and fan applications.

Settings

- Proportional gain: 0.01 to 100
- Integral gain: 0.01 to 100/second
- Feedback multiplied by K from 0.1 to 100

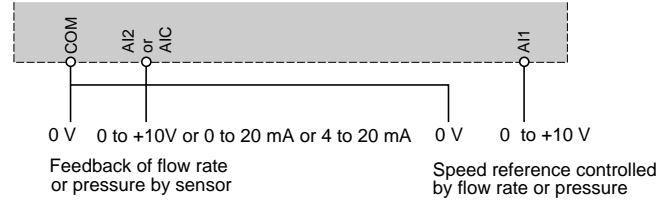

Note: PI regulator is not compatible with preset speeds (see page 18) or Jog (see page 18).

Volts/Frequency Options

Function

Performance of the application can be optimized by selecting the Volts/frequency option.

Applications

- Heavily loaded machines at low speed or machines with short cycles with sensorless flux vector control: ratio **n**.
- Constant torque applications (machines with average load at low speed) with motors connected in parallel or special motors (e.g., with resistive cage): ratio **L**.
- Variable torque applications (pumps, fans): ratio **P**.
- Energy savings for machines with slow variations in torque and speed: ratio **nLd**. The voltage is automatically reduced to the minimum depending on the torque required.

Auto-Tune

The Auto-tune function is for sensorless flux vector control (**n**) or energy savings (**nLd**) V/f options only. This function is activated from the keypad and can only be performed when the drive is stopped. It automatically measures the motor parameters and adapts the corresponding drive parameters.

Applications

For use on North American motors, when torque or stability performance is insufficient, or to obtain increased performance.



Switching Frequency

Function

The switching frequency can be adjusted to reduce the noise generated by the motor. Range is 2.2 to 12 kHz, factory setting of 4 kHz.

Applications

All applications requiring a low level of motor noise.

Adapting the Power

Above a frequency of 4 kHz (factory setting), the drive output current must be derated depending on the drive.

- ATV18U09M2, U18M2, U29M2, U41M2, U54M2: no derating required.
- All other catalog numbers:
 - > 4 kHz to 8 kHz: derate output current of drive by 5%.
 - > 8 kHz to 12 kHz: derate output current of drive by 10%.

The thermal protection of the drive automatically takes the adaptation into account. For example, for a 10% derating, 1.5 I_n becomes 1.35 I_n (activated after 60 seconds).

Skip Frequencies

Function

Suppression of critical speeds caused by mechanical resonance. It is possible to prohibit the prolonged operation of the motor at a preset frequency with a bandwidth of 2 Hz, adjustable from LSP to HSP.

Applications

Pumps and fans.

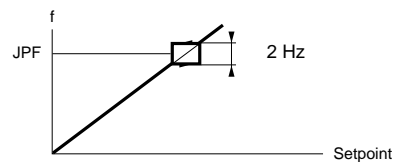

Factory setting: JPF = 0, no skip frequency set.

Controlled Stop on Loss of Input Power

Function

Controlled stop of the motor on a loss of input supply power. The drive follows a self-adjusting ramp which is a function of the regenerated energy.

Applications

Material handling, machines with high inertia, continuous process machines.

Factory setting: not active

Automatic Catching a Spinning Load with Speed Search

Function

Smooth restarting of the motor after a short input line undervoltage. When restarted, the effective speed of the motor is sought in order to restart on a ramp and return to the reference speed. The speed search time can reach 3.2 seconds depending on the initial deviation. This function requires the speed reference and the run direction command (FW or RV) to be maintained when restarted. Factory setting: not active.

Applications

Machines for which loss of motor speed is not great during input line undervoltage.



Automatic Restart

Function

Automatic restart after the drive trips on certain faults (see list below) if the cause of the fault has been corrected and operating conditions permit. The restart is made by a series of attempts performed at increasing intervals of 5 seconds, 10 seconds, then 1 minute. If the drive has not restarted after 6 minutes, it faults and must be manually reset. Factory setting is not active.

Faults which may be automatically restarted are:

- Overbraking
- Overvoltage
- Motor thermal overload
- Drive thermal overload
- Undervoltage (for undervoltage, automatic restart is always active even if it has not been configured).

If any of these faults occur, the fault relay remains closed if automatic restart is configured. Automatic restart requires the speed reference and the run direction to be maintained.

Applications

Machines or installations operating continually or without monitoring, where restarting does not present any danger for personnel or product (e.g., pumps or fans).

Low Speed Run Time

Function

The motor will run at low speed (LSP) for a time set by this function when the reference equals zero and a direction command (FW or RV) is present. The drive will restart when the reference exceeds zero or if the direction command is cycled. Low speed run time can be adjusted from 0.1 to 25.5 seconds. Setting this time to 0 deactivates the function (no timed stop).

Factory setting is not active.



Function Compatibility

The functions available on the ALTIVAR 18 drive are limited by the number of inputs and outputs on the drive and those required by the function. The ALTIVAR 18 drive has three assignable logic inputs and one assignable logic output (LI1 is defined as run forward and is not reassignable). The following functions require one logic input:

- Run reverse
- DC injection braking
- Fast stop
- Jog
- 2 preset speeds

Two logic inputs are required for 4 preset speeds.

Some logic functions take priority over other related functions, and there are incompatibilities between some logic functions. The following table describes the priorities and incompatibilities between logic functions.

	Automatic DC injection braking	Summing input	PI feedback	Forward direction	Reverse direction	DC injection braking by logic input	Fast stop	Jog	Preset speeds
Automatic DC injection braking							↑	↑	
Summing input			●						
PI feedback		●					↑	●	●
Forward direction					← ↑		↑		
Reverse direction				← ↑			↑		
DC injection braking by logic input							↑	←	←
Fast stop	←			←	←	←	↑	←	←
Jog	←		●			↑			
Preset speeds			●						

Function priority

●	Non-compatible functions	←	The function indicated by the arrow has priority over the other one.
	Compatible functions	↑	
	No significance	← ↑	The first operated has priority.



ALTIVAR 18 AC Drives
Drive Settings





SQUARE D

Square D Company
P.O. Box 27446
Raleigh, NC 27611 USA
(919) 266-3671

Square D, , and ALTIVAR are registered trademarks of Square D Company.

Catalog No. 8805CT9701 06/97 © 1997 Square D All Rights Reserved.