

ALTIVAR® 28 AC Drives

Class 8840

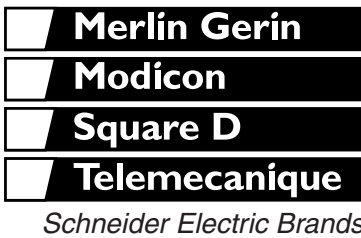

CONTENTS

Description	Page
Product Descriptions	5–7
Application and General Information	8–14, 40–43
Functionality	23–39
Specifications	48
Dimensions and Weights	49–52
Selection	53–54
Wiring and Fuse Recommendations	44–47
Accessories	15–22



ALTIVAR® 28 AC Drives

Contents

DESCRIPTION	PAGE
PRODUCT OVERVIEW.....	5
USER INTERFACE KITS.....	6
FIELD INSTALLED KITS.....	6
FEATURES	8
TECHNICAL CHARACTERISTICS	9
POWER TERMINALS	10
CONTROL TERMINALS	11
PROGRAMMING AND SETUP	12
REMOTE KEYPAD DISPLAY MOUNTING KIT.....	15
START/STOP/POTENTIOMETER KIT—VW3A28100	16
POWERSUITE SOFTWARE KIT.....	16
MAGELIS® TERMINAL	17
MODBUS COMMUNICATIONS KIT	17
SUMMARY OF USER INTERFACE OPTIONS.....	17
CONDUIT ENTRY KIT.....	18
DIN RAIL KIT.....	18
ATV18 REPLACEMENT KIT	18
DYNAMIC BRAKING RESISTOR KITS FOR 230/460 V CONTROLLERS	18
ELECTROMAGNETIC COMPATIBILITY (EMC) KITS	22
INTERNAL RFI FILTERS.....	22
EXTERNAL RFI FILTERS	22
DISPLAY PARAMETERS	23
ADJUSTMENT PARAMETERS.....	24
DRIVE AND MOTOR CONFIGURATION PARAMETERS	27
DRIVE CONTROL PARAMETERS	29
CONFIGURABLE I/O FUNCTIONS.....	30
FUNCTION COMPATIBILITY	30
ASSIGNMENT OF LOGIC INPUTS (LIX)	31
ASSIGNMENT OF ANALOG INPUTS (AIX)	34
ASSIGNMENT OF LOGIC OUTPUT (R2).....	35
ASSIGNMENT OF ANALOG OUTPUTS.....	35
FAULT MANAGEMENT PARAMETERS.....	36
PARAMETER SUMMARY	39
INSTALLATION	40
ATV28 MENU OVERVIEW	41
MOUNTING IN A TYPE 12 (OR IP54) METAL ENCLOSURE	42



ALTIVAR® 28 AC Drives
Contents

DESCRIPTION PAGE
WIRING RECOMMENDATIONS 44
RECOMMENDED FUSES 47
SPECIFICATIONS 48
DIMENSIONS AND WEIGHTS 49
ALTIVAR 28 53
SUPPORT 55





PRODUCT OVERVIEW

The ALTIVAR 28 (ATV28) adjustable frequency AC drive incorporates the latest sensorless flux vector technology in a compact design for three-phase asynchronous squirrel cage motors. This versatile drive offers increased performance while maintaining cost-effectiveness. The ATV28 provides advanced speed control capabilities for motors from 0.5–20 hp.

Industrial users and OEMs who specialize in small material handling, HVAC, pump, or general purpose motor control applications will find the ALTIVAR 28 drive well suited for their use.

Key benefits:

- Robust/Reliable
- Advanced design, simplified construction
- Reduced parts count and fewer internal electrical connections
- Conforms to/meets international standards
- Features/functions meet requirements of most applications
 - HVAC
 - pumping
 - simple machines
 - conveyors
 - packaging SFVC
- Integrated/on-board four-button, four to seven segment character display control
- Compact design reduces valuable panel space
- Provides an economical solution for communication capability for networking mini-drives into a system
- Analog output provides a simple, built-in speed indication signal that drives a remote meter while eliminating the expense of auxiliary signal devices
- The assignment of a logic input to fault reset and the automatic restart parameter minimize downtime.

ALTIVAR® 28 AC Drives

Options and Accessories

USER INTERFACE KITS



Start/Stop/Potentiometer Kit

This option consists of a reference potentiometer, a start button, and a stop/reset button in addition to the standard display functions.



Remote Keypad Display Mounting Kit

This kit can be used to mount a keypad display remotely. The keypad display has the same great features as the ATV28 drive controller with the added benefit of run, stop/reset, and forward/reverse buttons and a switch that allows for the menus to be locked. The kit has an IP65 rating. The kit includes a remote mount keypad display, hardware, and a three-meter cable.



MODBUS® Communication Kit

This kit is used to connect an ATV28 drive controller to a MODBUS network. With this kit, parameter configuration, control, monitoring, and diagnostic functions are accessible to the user over the network. This kit includes a register mapping guide and a three-meter cable with a 9-pin SUB-D female connector for connection to the network and an RJ-45 connector for connection to the ATV28 drive controller MODBUS port.



Software

Powersuite Test and Commissioning Software for PCs and HP® JORNADA® Pocket PCs

The Microsoft® WINDOWS®-based software can be used to display, configure, and adjust parameters as well as upload and download configurations. It can also be used to operate the drive and view the fault history. The PC software may be used in a stand-alone mode to create or modify a configuration and transfer it to an ATV28 drive controller.



Cable and connectors

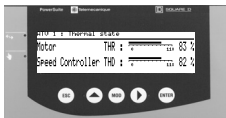

MAGELiS® Terminal

This user interface terminal can be used to connect with a single drive or multiple drives. The terminal can be used to monitor, make adjustments, and diagnose the ATV28 and ATV58 drive controllers.

FIELD INSTALLED KITS

Conduit Entrance Kits



This option is a conduit box that allows multiple (three or more) conduit entries. It attaches to the bottom of the drive controller. See the documentation supplied with the option for installation instructions. Without removal of the protective vent cover on the top of the drive controller and with the addition of this kit, the drive controller complies with UL Type 1.

ATV18 Replacement Kits

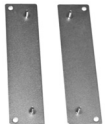

These kits contain brackets that adapt the spacing of the ATV28 mounting holes to be equivalent to that of the ATV18 drive. This allows the ATV28 drive to be secured to the panel holes and mounting hardware already in place for the ATV18 drive.

RFI Input Filter

The RFI Input Filter allows the drive to comply with European (CE) conducted emissions standard 55022 Class B. The Class A filter is built into the ATV28 drive. (ATV28•••N4, ATV28•••M2 only).



DIN Rail Kit

The DIN rail kit is for use with drive controllers ATV28HU09M2U and U18M2U. It allows the smaller drive controllers to be DIN rail mounted.

Dynamic Braking Resistor Kits

Dynamic braking resistors packaged in UL Type 1 enclosures are available for applications requiring fast cycle times. The kits mount separately.



ALTIVAR® 28 AC Drives

Features

FEATURES

The ATV28 family of adjustable frequency AC drive controllers is used for controlling three-phase asynchronous motors ranging from:

- 0.5–3 hp (0.37–2.2 kW) 208/230/240 V, single-phase input
- 5–10 hp (3–7.5 kW) 208/230/240 V, three-phase input
- 1–20 hp (0.75–15 kW) 400/460/480 V, three-phase input
- 1–20 hp (0.75–15 kW) 525/575/600 V, three-phase input

Operator interfaces, configuration tools, and communication options are shared throughout the product range.

The ATV28 drive controller uses the latest in AC drive technology. Intelligent power modules (IPMs) are used on the entire product family. The IPMs contain IGBTs (insulated gate bi-polar transistors) to produce a pulse width modulated (PWM) output waveform to the motor. IPMs minimize part count and improve reliability.

The ATV28 drive controller integrates third-generation sensorless flux vector control for three-phase asynchronous squirrel cage AC motors. This allows the drive controller to deliver needed torque with excellent dynamic response over a wide speed range.

ATV28 drive controllers are capable of:

- producing a transient maximum current of 150% of nominal drive controller current for 60 s
- output frequency ranges from 0.5–400 Hz
- 30% of nominal motor torque without dynamic braking (typical value); up to 150% with optional dynamic braking resistor
- switching frequency adjustments from 2–15 kHz
- drive controller protection through galvanic isolation between power and control (power supplies, inputs, and outputs)
- Protection against short circuits:
 - in available internal sources
 - between output phases
 - between output phases and ground for 7.5–20 hp drive controllers
- thermal protection against overheating and overcurrents
- undervoltage and overvoltage faults
- overbraking fault
- thermal motor protection integrated in the drive controller by calculation of I^2t

ATV28 drive controllers rated at 230 V and 460 V are available with an integrated EMC filter. This filter reduces conducted and radiated emissions, and complies with IEC product standards IEC 61800-3 and EN 61800-3 for drive controllers. Compliance with these standards meets the Class A requirements of the European directive on EMC.



TECHNICAL CHARACTERISTICS

Single Phase Supply Voltage: 208/240 V –15%, +10%, 50/60 Hz

Catalog No.	Input Line Current ♦		Motor Power		Rated Output Current	Transient Output Current ▲	Total Dissipated Power at Rated Load	SC Rating
	208 V	230 V	kW	hp				
	A	A			A	A	W	kA
ATV28HU09M2U	6.9	6.4	0.37	0.5	3.3	3.6	32	1
ATV28HU18M2U	9.3	8.6	0.75	1	4.8	6	45	1
ATV28HU29M2U	15.5	14.3	1.5	2	7.8	10.9	75	1
ATV28HU41M2U	21.3	19.8	2.2	3	11	15	107	1

Three-Phase Supply Voltage: 208/230 V –15%, +10%, 50/60 Hz

Catalog No.	Input Line Current ♦		Motor Power		Rated Output Current	Transient Output Current ▲	Total Dissipated Power at Rated Load	SC Rating
	208 V	230 V	kW	hp				
	A	A			A	A	W	kA
ATV28HU54M2U	16.8	15.4	3	4	13.7	18.5	116	5
ATV28HU72M2U	21.1	19.1	4	5	17.5	24.6	160	5
ATV28HU90M2U	36.3	33.2	5.5	7.5	27.5	38	250	22
ATV28HD12M2U	42.0	36.6	7.5	10	33	49.5	343	22

Three-Phase Supply Voltage: 400/460 V –15%, +10%, 50/60 Hz

Catalog No.	Input Line Current ♦		Motor Power		Rated Output Current ●	Transient Output Current ▲	Total Dissipated Power at Rated Load	SC Rating
	400 V	460 V	kW	hp				
	A	A			A	A	W	kA
ATV28HU18N4U	3.6	3.2	0.75	1	2.3	3.5	33	5
ATV28HU29N4U	6.1	5.4	1.5	2	4.1	6.2	61	5
ATV28HU41N4U	8.0	7.0	2.2	3	5.5	8.3	81	5
ATV28HU54N4U	9.8	8.6	3	–	7.1	10.6	100	5
ATV28HU72N4U	12.5	10.7	4	5	9.5	14.3	131	5
ATV28HU90N4U	21.5	18.6	5.5	7.5	14.3	21.5	215	22
ATV28HD12N4U	24.7	21.1	7.5	10	17	25.5	281	22
ATV28HD16N4U	37.5	32.8	11	15	27.7	41.6	401	22
ATV28HD23N4U	42.4	35.8	15	20	33	49.5	495	22

Three-Phase Supply Voltage: 575 V –15%, +15%, 60 Hz

Catalog No.	Input Line Current ★	Motor Power		Rated Output Current ●	Transient Output Current ▲	Total Dissipated Power at Rated Load	SC Rating
		kW	hp				
	A	kW	hp	A	A	W	kA
ATV28HU18S6XU	1.5	0.75	1	1.7	2.6	20	5
ATV28HU29S6XU	2.4	1.5	2	2.7	4.1	33	5
ATV28HU41S6XU	3.4	2.2	3	3.9	5.9	55	5
ATV28HU72S6XU	5.7	4	5	6.1	9.2	74	5
ATV28HU90S6XU	8.0	6	7.5	9.0	13.5	105	22
ATV28HD12S6XU	10.2	7.5	10	11.0	16.5	137	22
ATV28HD16S6XU	15.3	11	15	17.0	25.5	218	22
ATV28HD23S6XU	19.6	15	20	22.0	33.0	300	22

- ♦ Values correspond to the amount absorbed by drive controllers supplied with fault capacity equal to the short-circuit rating indicated in the table and under nominal conditions of load and speed of the associated motor without additional inductance.
- ▲ For 60 seconds.
- These power ratings are for a maximum switching frequency of 4 kHz, in continuous operation. The switching frequency is adjustable from 2 to 15 kHz. Above 4 kHz derate the nominal drive controller current. The nominal motor current should not exceed this value. Up to 12 kHz, derate by 10%, above 12 kHz derate by 20%.
- ★ Values correspond to the amount absorbed by drive controllers supplied with fault capacity equal to the short-circuit rating indicated in the table, and under nominal conditions of load and speed of the associated motor with the additional inductance of a 3% line reactor. *A 3% line reactor is required on all 575 V drive installations.* See page 54 for selection.



ALTIVAR® 28 AC Drives



Power Terminals

POWER TERMINALS

Power Terminal Wire Size and Torque

ATV28H*****	Max. Wire Size (75 °C copper)		Tightening Torque	
	AWG	mm ²	N•m	lb-in
U09M2U, U18M2U, U18S6XU, U29S6XU, U41S6XU	AWG 14	2.5	0.8	7.1
U29M2U, U18N4U, U29N4U, U72S6XU	AWG 12	3	1.2	10.7
U41M2U, U54M2U, U72M2U, U41N4U, U54N4U, U72N4U, U90S6XU	AWG 10	5	1.2	10.7
D12S6XU, D16S6XU	AWG 8	8	2.5	22.2
U90M2U, D12M2U, U90N4U, D12N4U, D23S6XU	AWG 6	16	2.5	22.2
D16N4U, D23N4U	AWG 3	25	4.5	40.0

Power Terminal Functions

Terminal ♦	Function	For ATV28H*****
	ATV28 controller ground terminal	Frame sizes 4–5
R/L1, S/L2	Input power	All models
T/L3		3-phase units only
PO	DC bus + polarity	All models
PA	Connection to braking resistor	All models
PB	Connection to braking resistor	All models
PC	DC bus – polarity	All models
U/T1, V/T2, W/T3	Output to motor	All models
Rightmost terminal 	ATV28 controller ground terminal	Frame sizes 4–5

♦ See the figure below for arrangement.

Power Terminal Arrangement

ATV28HU09M2U, U18M2U, U29M2U, U41M2U:

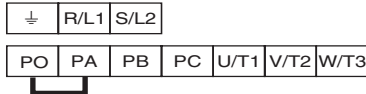

ATV28HU54M2U, U72M2U, U18N4U, U29N4U, U41N4U, U54N4U, U72N4U, U18S6XU, U29S6XU, U41S6XU, U72S6XU:

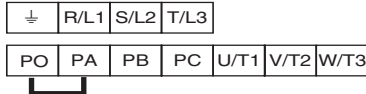

ATV28HU90M2U, D12M2U, U90N4U, D12N4U, D16N4U, D23N4U, U90S6XU, D12S6XU, D16S6XU, D23S6XU:



CONTROL TERMINALS

Control Terminal Description

Terminal	Function	Electrical specifications
R1A R1B R1C	R1A is a N.O. contact. When controller is powered with no fault, contact is closed. R1B is a N.C. contact. When controller is powered with no fault, contact is open. R1C is common.	Min. switching capacity • 10 mA for 5 Vdc Max. switching capacity on inductive load (cos φ = 0.4 and L/R = 7 ms): • 1.5 A for 250 Vac and 30 Vdc
R2A R2C	N.O. contact of R2 programmable relay	
COM	I/O common for logic	—
AI1	Analog voltage input. Used for speed reference input.	Analog input 0 to 10 V • impedance 30 kΩ • resolution 0.01 V • precision ± 4.3%, linearity ± 0.2%, of max. value • Sampling time 4 ms max.
+10	Power supply for speed reference potentiometer with a value between 1 and 10 kΩ	+10 V (+ 8% - 0), 10 mA max, protected against short-circuits and overloads
AI2 AIC	AI2 is an analog voltage input. Used for speed reference input or feedback. AIC is an analog current input. AI2 or AIC are assignable. Use either, but not both.	Analog input 0 to 10 V, impedance 30 kΩ Analog input X - Y mA. X and Y can be programmed from 0 to 20 mA, impedance 450 Ω Resolution, precision, and sampling time of AI2 or AIC = AI1.
AO	Analog output. Programmable for indication of motor current, motor frequency, motor torque, and motor power.	Output can be programmed for 0–20 mA or 4–20 mA with a Precision ± 6% of the max. value, max. load impedance 800 Ω.
LI1 LI2 LI3 LI4	Logic inputs. Function depends on configuration. See page 31.	Programmable logic inputs • + 24 V power supply (max. 30 V) • Impedance 3.5 kΩ • State 0 if < 5 V, state 1 if > 11 V • Sampling time 4 ms max.
+ 24	Logic input power supply	+ 24 V protected against short-circuits and overloads, min. 19 V, max. 30 V. Max. customer current available 100 mA

Control Terminal Arrangement

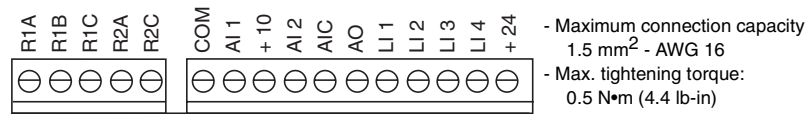

ALTIVAR® 28 AC Drives

Programming and Setup

PROGRAMMING AND SETUP

Preliminary Recommendations

When using a line contactor to start the drive controller from line power, limit operations of the line contactor to less than once per minute to avoid premature failure of the filter capacitors and precharge resistors. The preferred method of control is to use inputs LI1 to LI4. This is vital for cycles less than 60 seconds; otherwise the load resistor may be damaged. Ensure that the programmed settings are compatible with the wiring layout.

When first commissioning a 230/460 V ATV28 drive controller on a 60 Hz system, if bFr does not appear, perform a factory parameter reset (see parameter FCS on page 41). When parameter bFr appears on the display, set it to 60. The proper setting of bFr is important because it affects many of the drive controller functions. Since 575 V models are only rated for 60 Hz, parameter bFr is not displayed.

Programming the ATV28 controller is simplified by internal sequence selections and interlocks. For ease of setup, Square D recommends accessing the menus in the following order:

1. I/O
2. drC
3. Set

Some steps may not be necessary.

Factory Settings

The ALTIVAR 28 drive controller is preset for most constant torque applications. The table below lists some factory settings.

Function	Setting
Display	Drive ready (when stopped) Reference frequency (when running)
Base frequency	50 Hz ♦ (60 Hz for 575 V)
Motor voltage	230 V, 400 V, or 575 V, depending on the model
Acceleration and deceleration ramps	3 s
Low speed	0 Hz
High speed	50 Hz (60 Hz for 575 V)
Frequency loop gain	Standard
Motor thermal current	Nominal drive controller current
DC braking current at stop	0.7 times nominal drive controller current for 0.5 s
Operation	Constant torque with sensorless vector control
Logic inputs	2 run directions (LI1, LI2) 4 preset speeds (LI3, LI4): 0 Hz, 5 Hz, 25 Hz, 50 Hz
Analog inputs	AI1: 0 to +10 V reference AI2 (0 to +10V) or AIC (0 to 20 mA) summed with AI1
Relay R2	Speed reference reached
Analog output	0–20 mA, motor frequency
Deceleration ramp adaptation	Automatic in the case of overvoltage when braking
Switching frequency	4 kHz

♦ To change base frequency to 60 Hz, see page 13.

To modify these adjustments, use the keypad to change the parameter settings. The following section explains the keypad and parameters.



Using the Keypad Display

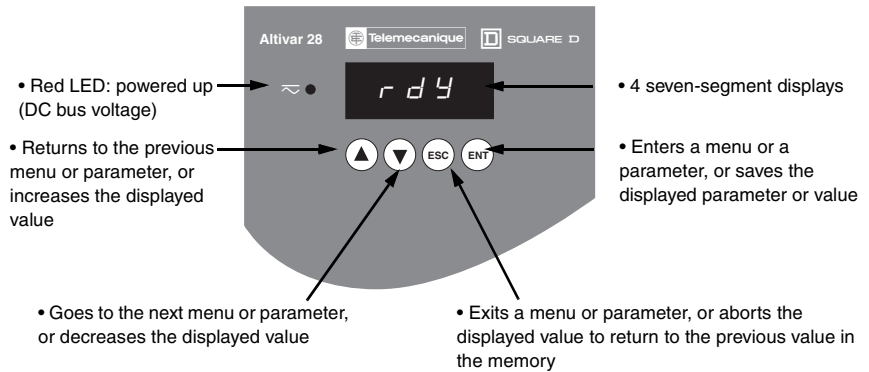

Keypad Display

NOTE: Pressing or does not store the choices. To store the displayed choice, press . The display flashes when a value is stored.

Normal display, with no fault present:

- Init: Initialization sequence
- rdY: Drive controller ready
- xx.x: Frequency reference (for example, 43.0)
- dcb: DC injection braking in progress
- rtrY: Automatic restart in progress
- nSt: Freewheel stop command
- FSt: Fast stop command

Access to Menus

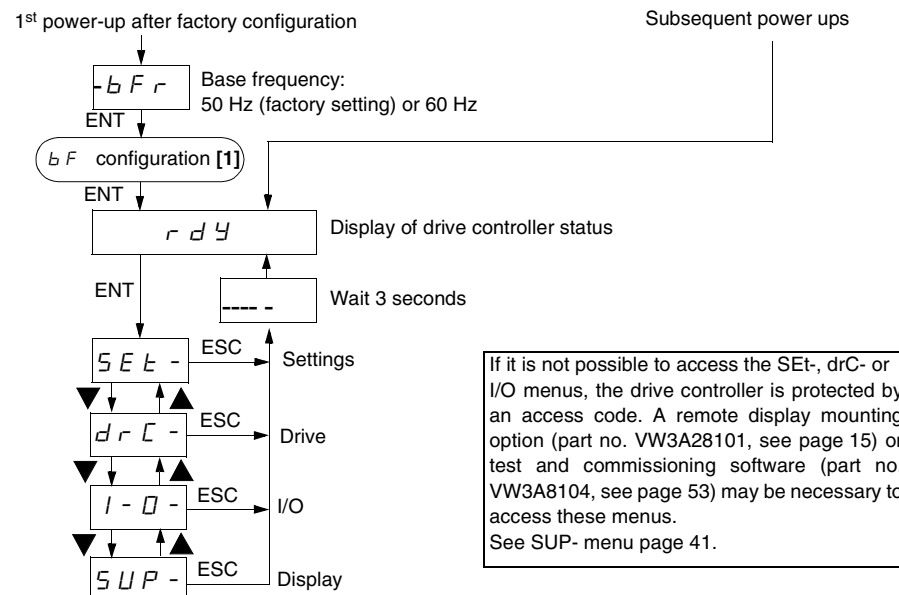

[1] The proper setting of parameter bFr is important because it affects many other drive controller functions. In 208/230 V and 400/460 V models, this parameter comes factory set to 50 Hz. When



ALTIVAR® 28 AC Drives Programming and Setup

commissioning one of these models for use on a 60 Hz system, first perform a factory parameter reset (see parameter FCS on page 41) and then adjust bFr to 60. Since 575 V models are only rated for 60 Hz, parameter bFr is not displayed..

Access to Parameters

There are three types of parameters:

- Display: values displayed by the drive controller.
- Adjustment: can be changed during operation or when the controller is stopped.
- Configuration: can only be modified when the controller is stopped and the motor is not braking. Parameters can be displayed during operation

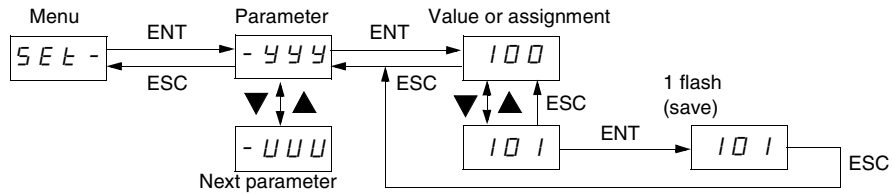

VW3A28101

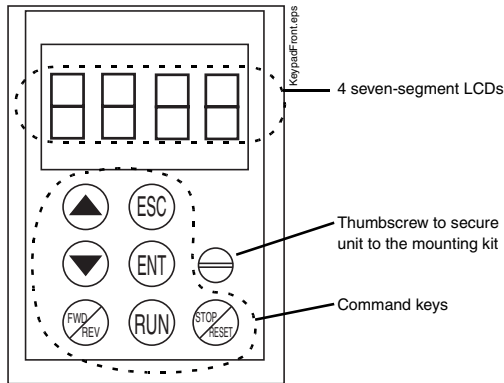

The Front of the Remote Keypad Display Showing the Keypad Display and Command Keys

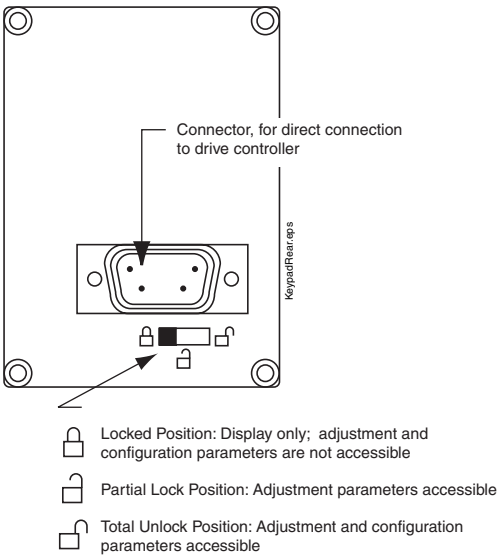

The Rear of the Keypad Display Showing the Access Control Switch and Connector

REMOTE KEYPAD DISPLAY MOUNTING KIT

This module can be mounted on the door of a wall-mounted or floor-standing enclosure. The kit includes a keypad, mounting hardware, and a three-meter cable. The cable is connected to the drive controller serial link (see the instruction sheet supplied with the display module). It has the same display and the same programming buttons as the ATV28 drive controller with the addition of a switch to lock access to the menus and three buttons for controlling the drive controller.

The functions of the keys are explained below:

- Press to move within menus or among the parameters, or to adjust a displayed value up or down.
 - Press to return to the previous menu, or abandon an adjustment in progress and return to the original value.
 - Press to select a menu, or validate and save a choice or adjustment.
- If command by the keypad is selected, the following keys are active:
- Press to change the direction of motor rotation.
 - Press to start the motor.
 - Press to stop the motor or reset a fault. The STOP key can also stop the drive controller in terminal block command mode. Pressing the button once stops the motor, and if DC injection standstill braking is configured, pressing the button a second time stops the braking.

Access Control

On the rear of the keypad display is a three-position, access control switch and a connector (see the figure to the left). Access may also be controlled by using an access code.

The switch setting can deter unwanted tampering with adjustment and/or configuration parameters.

Principle of Access to Menus

When a remote keypad display is the user interface, access is controlled by the three-position switch on the rear of the keypad (see the figure to the left). What is permitted with each setting is described below:

- With the switch in the locked position, the user can:
 - display the firmware version
 - display the state of the controller
 - display the electrical values
 - display the last fault register
- With the switch in the partially locked position, the user can:
 - Perform the operations possible when the switch is in locked position
 - Modify settings
- With the switch in the total unlock position, the user can:
 - Perform the operations possible when the switch is in locked or partial locked positions
 - Modify the motor power
 - Modify all configuration parameters
 - Enable control of the controller via the terminal

When a PC is the user interface, no access restrictions exist unless an access code is configured (in which case, the access code must be entered to perform any actions).



ALTIVAR® 28 AC Drives

User Interface Options and Accessories



START/STOP/POTENTIOMETER KIT—VW3A28100

This option consists of a reference potentiometer and provides access to two additional buttons on the drive controller (see documentation provided with the option):

- RUN button: Starts the motor. The direction of operation is determined by parameter rOt in the settings menu SEt-.
- STOP/RESET button: controls the stopping of the motor and the clearing (resetting) of any faults. The first press on the button stops the motor, and if DC injection standstill braking is configured, a second press stops this braking.

The reference given by the reference potentiometer is summed with analog input AI1. Installing this option changes the factory setting of certain functions (see page 12):

I/O Menu:

- tCC = OPt not reassignable
- LI1 = no not reassignable
- LI2 = PS2 reassignable
- LI3 = PS4 reassignable
- LI4 = PS8 reassignable

This option must be connected with the drive controller powered down, otherwise it will trip on an InF fault.

NOTE: After this option is installed, it is not possible to restore the original faceplate to the drive controller.

POWERSUITE SOFTWARE KIT



Software



Cable and connectors

The Powersuite software is a WINDOWS-based, intuitive graphical user interface to the ALTIVAR family of AC drive controllers, including the ATV28. The software can be used with a PC using Microsoft® WINDOWS 95, WINDOWS 98, or WINDOWS NT™ operating systems or an HP JORNADA 520 or 540 series pocket PC using WINDOWS CE v3.0 operating system. The connection is made with a serial link between the terminal port and the PC serial port.

The Powersuite test and commissioning software allows you to:

- run the drive
- create, modify, and store drive configurations
- transfer data to and from the drive
- display and view run time data
- display and view faults and the fault history
- print a hard copy of the drive configuration for reference
- configure the software operator dialog in five languages

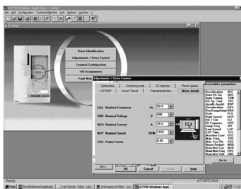

When using the software, no access restrictions exist unless an access code has been configured.



ALTIVAR® 28 AC Drives User Interface Options and Accessories

MAGELIS® TERMINAL



The MAGELiS terminal offers a unique solution for upgrading the user interface to one drive or multiple drives. The MAGELiS terminal can be used to connect up to eight drive controllers via a MODBUS RS-485 multi-drop link. The MAGELiS terminal can be used with ATV28 and ATV58 drive controllers. The display has a 240 x 64 pixel monochrome matrix backlit display.

The MAGELiS terminal has a factory loaded HMI application. This is easily modified with the XBT-L1003 software package to customize and configure the display. The terminal can be used to monitor, make adjustments to, and diagnose the drive controller. Drive status, operating parameters, and I/O status can be viewed.

The terminal requires a 24 Vdc power supply. A cable, (XBTZ908) is included for connection to a TSXSCA62 tap. The ATV28 drive with a MODBUS communications kit (VW3A28301U) can be connected to the tap with the RS-485 Connection Kit (VW3A58306U) cable.

MODBUS COMMUNICATIONS KIT



This option allows multiple ALTIVAR 28 drive controllers to be connected to the MODBUS network. The controllers can receive and respond to data messages. This data exchange enables a network to access ATV28 functions such as

- Remote loading of configuration parameters
- Command and control
- Monitoring
- Diagnostics

Refer to instruction bulletin VVDED399092US supplied with the MODBUS kit.

SUMMARY OF USER INTERFACE OPTIONS

The following table lists the various user interface options and provides a catalog number for ordering.

User Interface Option	Description	Catalog Number
Start/Stop/Potentiometer Kit	This kit consists of a reference potentiometer and provides access to Run and Stop/Reset buttons. This option cannot be removed once it has been fitted.	VW3A28100
Remote Keypad Display Mounting Kit	This kit may be used to locate the keypad display remotely (for example, on the door of the enclosure). The kit includes the remote keypad display, a 3-meter (9.8 foot) cable with connectors, a translucent protective cover for the keypad, and seals and screws for IP65 mounting on an enclosure door.	VW3A28101
Powersuite Software Kit	This software is used to establish a link and interface with the ATV28 drive. It allows the user to monitor and control drive functions, and to configure and store drive parameters. It can be used with a PC using Microsoft WINDOWS 95, WINDOWS 98, or WINDOWS NT 4.X operating systems or an HP JORNADA 520 or 540 series pocket PC using WINDOWS CE v3.0 operating system.	VW3A8104
Pocket PC Powersuite Pak	Includes an HP JORNADA 545 pocket PC with AC charger, serial cable, stylus pen, carrying case, Powersuite software (VW3A8104), and connection kit (VW3A8111).	VW3A8108US
Compact Flash Modules	Modules loaded with Powersuite software, for use with the HP JORNADA 520 or 540 series pocket PC.	VW3A8110
Pocket PC Connection Kit	Includes a 0.5 m cable, RS-232 to RS-485 adapter, and an RJ45 to DB9 adapter for use with the ATV58 controller.	VW3A8110
PC Cable for Test and Commissioning Software	This option includes a 3-meter (9.8 foot) cable, an RS-485/RS-232C adapter, and connectors to an ATV28 or ATV58 drive.	VW3A8106
MODBUS Communications Kit	This kit allows RS-485 multidrop serial link connection to PLCs, man-machine terminals. The kit includes a 3-meter (9.8 foot) cable and a manual.	VW3A28301U
MAGELiS Terminal	This user interface terminal is used in conjunction with MODBUS RS-485 communication kits (VW3A28301U and VW3A58306U, not included) and a tap (TSXSCA62, not included). A cable (XGTZ908) is included.	XBTHM017010AA8



ALTIVAR® 28 AC Drives Field Installed Options



CONDUIT ENTRY KIT

This option is a conduit box allowing three or more conduit entries. It attaches to the bottom of the drive controller. See the documentation supplied with the option for installation instructions. Without removal of the vent cover on the top of the drive controller and with the addition of this kit, the drive controller complies with UL Type 1 standards.

Kit Catalog No.	Drive Controller Catalog No. ATV28H*****
VW3A28811A	U09M2U, U18M2U
VW3A28812A	U29M2U, U18N4U, U29N4U, U18S6XU, U29S6XU
VW3A28813A	U41N4U, U54N4U, U72N4U, U41M2U, U54M2U, U72M2U, U41S6XU, U72S6XU
VW3A28814A	U90M2U, D12M2U, D12N4U, U90N4U, U90S6XU, D12S6XU
VW3A28815	D16N4U, D23N4U, D16S6XU, D23S6XU

DIN RAIL KIT

The DIN rail kit is for use with drive controllers ATV28HU09M2U and U18M2U. It allows these smaller drive controllers to be DIN rail mounted.

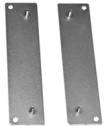

ATV18 REPLACEMENT KIT

This option provides brackets that allow an ATV28 drive controller to be secured to existing panel mounting holes for an ATV18 drive controller.

Kit Catalog No.	Drive Controller Catalog No. ATV28H*****
VW3A28821A	U09M2U, U18M2U
VW3A28822	U29M2U, U18N4U, U29N4U
VW3A28823	U41N4U, U54N4U, U72N4U, U41M2U, U54M2U, U72M2U
VW3A28824	U90M2U, D12M2U, D12N4U, U90N4U
VW3A28825	D16N4U, D23N4U

DYNAMIC BRAKING RESISTOR KITS FOR 230/460 V CONTROLLERS



The dynamic braking resistor kit allows the ATV28 drive controllers to function in quadrants 2 and 4 of the four quadrant speed/torque curve. In these quadrants of motor operation, the motor is essentially a generator through which energy is transferred from the motor load back to the drive controller. This results in elevated DC bus voltage to the drive controller which may cause it to shut down to protect itself. Dynamic braking resistor kits are commonly used to dissipate the excess energy generated by the motor operating in this mode. The flow of current to the braking resistor is controlled by the dynamic braking transistor. Applications include machines with high inertia, overhauling loads, and machines with fast cycles.

The following table shows the minimum ohmic value of the resistor that can be used with the ATV28 drive controllers. Using lower than recommended values will cause excessive current flow, exceeding the rating of the dynamic braking transistor.



Minimum Dynamic Braking Resistance Values

208/230 V Drive Controller Part No.	PA / PB Minimum Resistance Ω	460 V Drive Controller Part No.	PA / PB Minimum Resistance Ω	575 V Drive Controller Part No.	PA / PB Minimum Resistance Ω
ATV28HU09M2U	65	ATV28HU18N4U	95	ATV28HU18S6XU	100
ATV28HU18M2U	45	ATV28HU29N4U		ATV28HU29S6XU	
ATV28HU29M2U	30	ATV28HU41N4U	70	ATV28HU41S6XU	85
ATV28HU41M2U		ATV28HU54N4U		ATV28HU72S6XU	65
ATV28HU54M2U	25	ATV28HU72N4U	45	ATV28HU90S6XU	38
ATV28HU72M2U		ATV28HU90N4U		ATV28HD12S6XU	
ATV28HU90M2U	10	ATV28HD12N4U	25	ATV28HD16S6XU	
ATV28HD12M2U		ATV28HD16N4U		ATV28HD23S6XU	
		ATV28HD23N4U			

The following charts show the motor braking torque capacity of an ATV28 drive controller with a braking resistor.

Braking Torque with Resistor

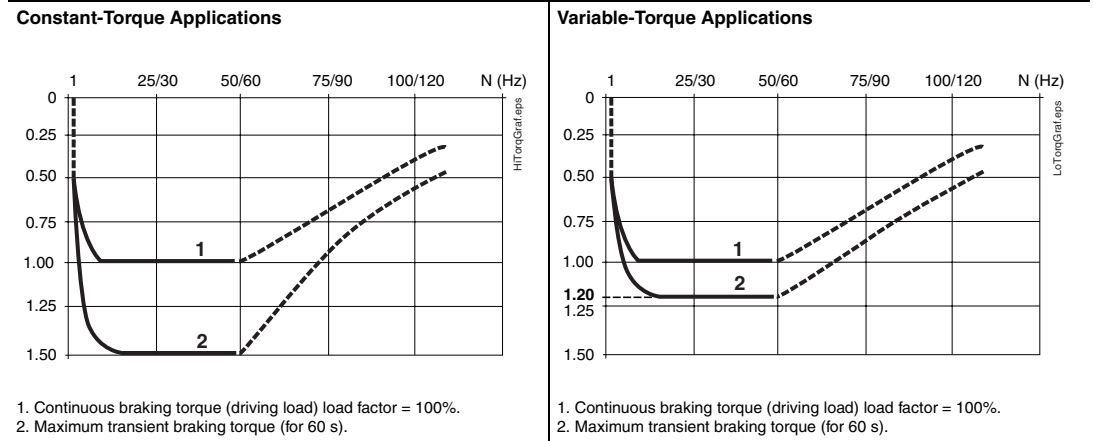

Calculating Resistor Size

The standard dynamic braking (DB) resistor assemblies are suitable for a wide variety of drive system stopping applications. However, when the driven machinery may present an overhauling load or large inertia to the drive system, the suitability of the DB resistor assembly should be checked.

The suitability of a DB resistor assembly is determined by analyzing the mechanical system of the driven machinery. From the analysis, the following key parameters are computed:

- The peak braking power required during stopping or speed changes (P_i). The value of P_i determines the maximum allowable ohmic value of the DB resistor.
- The amount of power that must be absorbed (P_d) for a given time (t_d) by the DB resistors during stopping or speed changes of the drive. The value of P_d and T_d determine the required time-current characteristic of the DB resistor.
- The calculation of dynamic braking power requires V_{db} .
- $V_{db} = 1020$ V for 575 V drives
 $V_{db} = 850$ V for 460 V drives
 $V_{db} = 375$ V for 230 V drives
- The average power that must be dissipated by the DB resistor during an entire cycle of the machine (P_a). The value of P_a determines the required continuous current rating of the DB resistor.



ALTIVAR® 28 AC Drives Field Installed Options

The following example illustrates the process:

Given

The application consists of a 5 hp, 460 Vac, 1740 rpm motor (N_{base} = base speed) with a rotor inertia of 0.28 lb-ft². The motor is being controlled by an ATV28HU72N4 operating in the constant torque mode. The motor is driving a machine with an inertia 10 times that of the motor with no interposing gear box. The machine resistive (friction) torque is one-tenth of the rated motor torque at full speed. The requirement is to stop in 5 seconds from rated speed at a rate of 2 cycles/minute.

Mechanical System Parameters:

Rated motor torque: $T_n = (HP \times 5250)/N_{base} = (5 \times 5250)/1740 = 15.1$ lb-ft

Machine cycle time: $t_c = (60 \text{ seconds})/(\text{two operations per minute}) = 30$ seconds

Machine speed change during deceleration: $N_d = 1740 \text{ rpm} - 0 \text{ rpm} = 1740$ rpm

Machine deceleration time: $t_d = 5$ seconds

Mechanical system resistive (friction) torque: $T_r = (15.1 \text{ lb-ft})/10 = 1.51$ lb-ft

Mechanical system overhauling torque: $T_o = 0.00$ lb-ft

Mechanical system combined inertia: $J_c = 0.28 \text{ lb-ft}^2 + (10) \times 0.28 \text{ lb-ft}^2 = 3.08 \text{ lb-ft}^2$

Mechanical system inertial torque for a 5 second deceleration rate (as set by controller deceleration ramp):

$T_j = J_c \times (N_d)/(308 \times (t_d)) = 3.08 \times 1740/(308 \times 5) = 3.48$ lb-ft

Required braking torque from motor: $T_b = T_j + T_o - T_r = 3.48 + 0.00 - 1.51 = 1.97$ lb-ft

NOTE: The required braking torque must not exceed the motor's ability to produce torque. For inertial loads, including those depicted in the above examples, the required braking torque must not exceed the torque producing ability of the dynamic braking unit with the recommended braking resistor (approximately 1.5 times the motor rated torque for constant torque applications).

For machines that can continuously overhaul the motor, the value of overhauling torque (T_o) minus the resistive torque (T_r) must not exceed the motor continuous torque rating at any speed.

DB resistor requirements:

Peak braking power required to develop braking torque (T_b) when decelerating from a given speed

$P_i = T_b \times N_{base}/(7.04) = (1.97 \times 1740)/(7.04) = 487$ W

The braking power that must be absorbed for a time (t_d) during stopping or speed changing operation: $P_d = 0.5 \times P_i = 0.5 \times 487 = 243$ W for a period of t_d seconds

The average braking power that must be dissipated during a machine cycle:

$P_a = P_d \times t_d/t_c = 243 \times 5/30 = 40.5$ W

Capability of VW3A66711 DB resistor assembly for ATV28U72N4 controller:

Peak braking power that can be developed with VW3A66711 DB resistor assembly with controller configured for 460 Vac input line operation: $P_i = (V_{db})^2/R_{db} = (850 \text{ V})^2/120 \Omega = 6020$ W

The braking power that can be absorbed for t_d (based on DB resistor hot state current-time characteristic curve shown below):

$P_d = R_{db} \times ((\text{Multiple of } I_r \text{ at } t_d) \times I_r)^2 = 120 \Omega \times (3.5 \times 1.0)^2 = 1470$ W

Since R_{db} limits the peak current that can be drawn from the drive controller DC bus, the value of $[(\text{Multiple of } I_r) \times I_r]$ must be limited to no greater than $(\sqrt{P_i/R_{db}})$.

The average braking power that can be dissipated continuously:

$P_a = R_{db} \times (I_r)^2 = 120 \Omega \times (1)^2 = 120$ W

For this example, the VW3A66711 DB resistor assembly will work as intended for the application.



Current/Time Characteristics for DB Resistor Assemblies

The figure below shows the allowable GV2 trip times as a function of current setting multiples with the dynamic braking resistor assembly located in a 40 °C (104 °F) ambient temperature environment. See page 19 for an example of how to calculate resistor size.

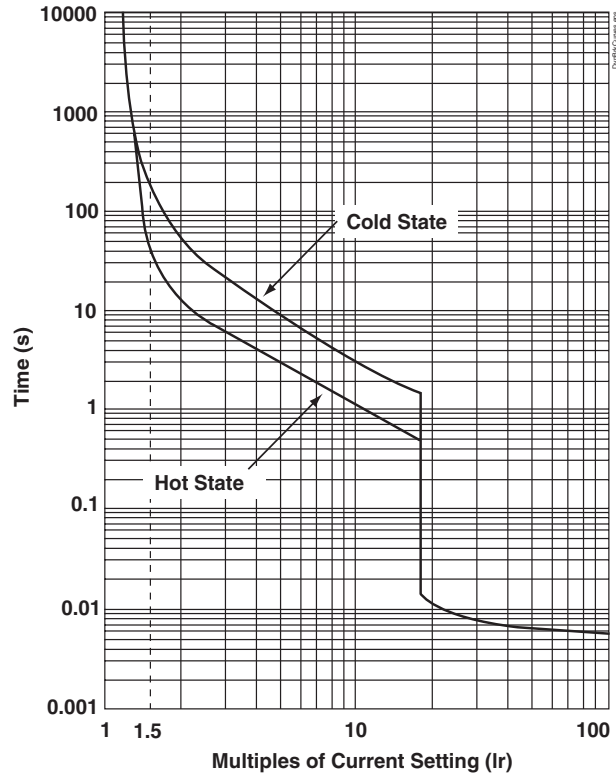

The kits in the following table use the thermal protection of a GV2 manual starter and have a Type 1 rating per UL 50. The insulation system is suitable for use in a Pollution Degree 3 environment (refer to NEMA ICS-1 Annex A). The package is UL/CSA marked.

Dynamic Braking Kits Technical Specifications

Dynamic Braking Kit for:	Ohmic Value (Rdb) Ω	Continuous Current Rating of Assembly ♦ (Ir) A	Average Power (W)	Catalog Number
ATV28HU09M2U	120	1.0	120	VW3A66711
ATV28HU18N4U–U72N4U				
ATV28HU18M2U–U41M2U	56	1.45	118	VW3A66712
ATV28HU90N4U–D12N4				
ATV28HU54M2U–U72M2U	28	2.7	204	VW3A66713
ATV28HD16N4U–D23N4U				
ATV28HU90M2U–D12M2U	14	3.8	202	VW3A66714

♦ Current rating of resistor assembly is calculated based on setting of internal overload protective device in assembly, overload setting based on enclosure overtemperature protection, and resistor overload time characteristics. Resistors are rated for stopping six times rotor inertia of four-pole motor with drive at current limit. Motor inertias are based on NEMA MG-1 14.45.



ELECTROMAGNETIC COMPATIBILITY (EMC) KITS

ATV28 drive controllers are marked with the CE European Community mark.

The ATV28 drive controller is considered to be a component. It is neither a machine nor a piece of equipment ready for use in accordance with the European Community directives (machinery directive or electromagnetic compatibility directive). It is the user's responsibility to ensure that the machine meets these standards.

Metal EMC plate kits are included with each ATV28 drive controller to assist in meeting the European Community EMC directives. The plate is used for landing the shield of the shielded cable. These kits are for integrators and end-users who are including the drive controller as part of a machine to be exported to Europe requiring compliance to these directives. When installed as directed in Instruction Bulletin VVDED399062US (shipped with the drive), the requirements of EMC Directive Level A will be met. To achieve Level B compliance, install an external RFI filter (see following sections). See page 49 for EMC kit dimensions.

INTERNAL RFI FILTERS

All ATV28 drive controllers rated at 230 V and 460 V are equipped with integrated internal radio interference suppression input filters to comply with the EMC "products" standards IEC 1800-3 and EN 61800-3 concerning variable speed controllers. Compliance with these standards meets the Class A requirements of the European directive on EMC.

575 V ATV28 drive controllers are not equipped with integrated input filters.

EXTERNAL RFI FILTERS

External RFI input filters are available to meet the strictest requirements. These filters are designed to reduce conducted emissions on the mains supply to below the limits of standards EN 55022 class B or EN 55011 class A. The motor cable must be longer than 5 m (16 feet).

External RFI filters are mounted beneath ATV28 controllers. They have tapped holes for mounting the drive controller which they support. The filters are mounted to the side of ATV28 controllers.

RFI filters can only be used on TN type (connected to neutral) and TT type (neutral to ground) mains supplies. They must not be used with IT (impedant or isolated neutral) mains supplies. Standard IEC 1800-3, appendix D2.1, states that filters must not be used with IT mains supplies because they prevent the ground leakage detectors from working reliably. In addition, the effectiveness of the filters on IT mains supplies depends on the type of impedance between neutral and earth, and is therefore not recommended.

In the case of a machine which must be installed on an IT supply, the solution is to insert an isolation transformer and operate the machine locally using a TN or TT supply.

Characteristics of External RFI Filters

Conformity to standards		EN 133200
Degree of protection		IP 21 and IP 41 on upper part
Maximum relative humidity		93% with no condensation or dripping water, conforming to IEC 68-2-3
Ambient air temperature	Operation	-10 to 60 °C (14 to 140 °F)
	Storage	-25 to 70 °C (-13 to 158 °F)
Operating altitude	Up to 1000 m (3280 feet)	No derating required
	Above 1000 m (3280 feet)	Derate the current by 1% for each additional 100 m (328 feet)
Maximum nominal voltage	50/60 Hz single-phase	240 Vac +10%
	50/60 Hz 3-phase	500 Vac +10%

Refer to page 50 for dimensions and to page 54 for selection.

DISPLAY PARAMETERS

The display parameters, described in the following tables, can be viewed in any access level from the Display menu. Use the arrow keys on the keypad display or programming terminal to scroll through this parameter set. The following parameters can be viewed under Drive State in the Display menu. They are used for monitoring drive controller operation.

Parameter	Units	Description
Reference Frequency	Hz	Displays the frequency the drive controller is commanded to run
Output Frequency	Hz	Displays the output frequency being applied to the motor
Motor Speed	—	Displays the value calculated by the drive controller (rFR x SdS)
Motor Current	A	Displays the motor current
Output Power	Opr	Displays the power supplied by the motor, estimated by the drive controller. 100% corresponds to the nominal drive controller power.
Line Voltage	ULn	Displays the line voltage
Motor Overload	LHr	Displays the motor thermal state: 100% corresponds to nominal
Motor Thermal State	LHd	Displays the drive controller thermal state: 100% corresponds to the nominal thermal state. Above 118%, the drive controller triggers an OHF fault (drive overheated). It can be reset below 70%.
Last Fault	LFL	View the last fault which appeared. If there has been no fault, the display shows: noF.
Firmware Version	CPU	Drive controller firmware version
Access Code	Cod	Parameter can be seen and accessed on drive controllers with firmware versions V11_12 (230/460 V) and V77_15 (575 V) or later. With previous firmware versions, this parameter can only be seen and accessed using a remote display module option or Test and Commissioning software. Access code: 0 to 9999. Value 0 (factory setting) does not prevent access. All other values lock access to the Set-, drC-, and I-O- menus. To lock access to the drive controller, the code can be incremented using (▲▼) then saved using ENT. To access the menus on a drive controller which is locked by a code, the code can be incremented using (▲▼) and confirmed with ENT: When the correct access code is displayed, it flashes, and code 0 can then be configured in order to access the menus. When an incorrect code is displayed, the drive controller returns to the initial display (rdY).
Drive State	Init RdY Dcb rtrY nSt FSt	Display of the drive controller status: the operating phase of the motor or a fault. Initialization sequence Drive controller ready DC injection braking in progress Automatic restart in progress Freewheel stop command Fast stop command



ALTIVAR® 28 AC Drives

Adjustment Parameters

ADJUSTMENT PARAMETERS

Adjustment parameters can be viewed and modified when access parameter, COD, is set to 0 (unlocked) or when the access locking switch on the remote keypad display is not in a locked position (see page 15). Adjustment parameters can be modified with the motor stopped or running.

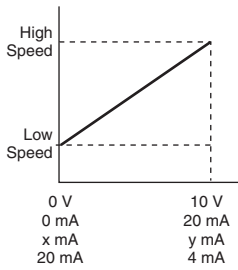

Low Speed and High Speed

These two frequency limits define the speed range permitted, as shown in the graph to the left. Low speed is adjustable from 0 to the High Speed setting and is factory set at 0 Hz. High Speed is adjustable from Low Speed to 400 Hz and is factory set to 50 or 60 Hz depending on the base frequency configuration. Note that the speed reference input is scaled between Low Speed and High Speed. It is possible to modify the scaling with the Low Speed parameter.

Acceleration and Deceleration Ramp Times

The ramp times for acceleration and deceleration are determined by the requirements of the application and the dynamics of the machine. The following table shows the acceleration and deceleration settings.

Acceleration	Deceleration
Adjustment from 0.0 to 3600 s, preset at 3 s.	Adjustment from 0.0 to 3600 s, preset at 3 s.

Alternate Ramp Switching Using Frequency Threshold

Alternate ramp switching allows switching between two sets of acceleration and deceleration ramp times, with each set being adjusted separately. To switch between the two sets, a frequency threshold can be defined. (A logic input may also be configured for ramp switching; see page 31.)

Ramp switching is particularly suited for the following:

- Material handling applications that require smooth starting and approach
- Applications involving fast, steady-state speed correction
- High-speed lathes with limitation of acceleration and deceleration above certain speeds

Skip Frequency

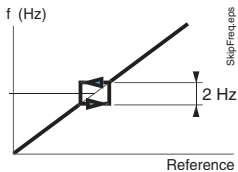

This parameter, also referred to as jump frequency, allows suppression of a critical speed which causes mechanical resonance phenomena. Prolonged operation of the motor within a frequency band of 2 Hz is prohibited. The frequency band is adjustable over the speed range. A representation of this is shown to the left.

This function is useful for applications involving light-weight machines, such as bulk product conveyors, with unbalanced motors. It is also useful for applications involving fans and centrifugal pumps.

Low Speed Run Time Limit

This function, also referred to as a sleep function, is used to stop the motor after running at low speed for a programmed amount of time, with the run command present and zero speed reference. The length of run time at low speed is adjustable from 0.1 to 25.5 seconds. The factory setting is 0 s, which disables this function. In two-wire control, the motor will restart if the frequency reference becomes greater than the low speed and a run command is still present. In three-wire control, another run command must be given to restart.

This function is used for automatic starting and stopping of pressure-regulated pumps.

IR Compensation

This parameter is used to adjust low-speed torque for optimal performance. Adjust this parameter to compensate for the resistive voltage drop of the motor stator windings and the conductors connecting the motor and drive controller.

The factory setting is 20% (15% for 575 V), with a range of 0 to 100%.

This parameter is typically used to boost torque performance during low speed operation. If an auto-tune is performed, adjustment of this parameter is usually not required.

Slip Compensation

This parameter is used to adjust the slip compensation to improve speed regulation. This parameter only appears when the drive is configured for sensorless flux vector control. The adjustment range is from 0 to 5 Hz.

Induction motors develop torque based on the slip, which is the difference between the speed of the rotating magnetic field in the stator and the speed of the rotor. As the load increases, the slip increases to produce the necessary torque. In applications where this slip is undesirable, the slip compensation should be increased. When this parameter is increased, the drive controller will automatically increase the output frequency.

Gain

This parameter allows adjustment of the drive controller's response time to sudden changes in the motor load. The factory setting is 33%, with a range of 0 to 100%.

Decreasing the gain parameter slows the response time of the drive. Increasing the gain parameter makes the drive respond more quickly. This parameter should be increased when it is not desirable for motor speed to change as the motor load changes, such as in applications that have fast cycle times or high torque requirements.

DC Current Injection

This parameter allows the drive to inject DC current into the stator, creating a stationary magnetic pole which brakes the rotor at the end of each stop command when the frequency drops below 0.1 Hz.

This feature is useful when a coasting motor is undesirable at the end of the deceleration ramp. The time of DC current injection is adjustable from 0 to 25.4 seconds, with a factory setting of 0.5 seconds. A continuous setting is also available at 25.5 seconds. If the continuous setting is selected, the drive controller brakes at the set level of DC current for 5 seconds, and then continuously at 50% of rated current or the set level, whichever is less.



ALTIVAR® 28 AC Drives Adjustment Parameters

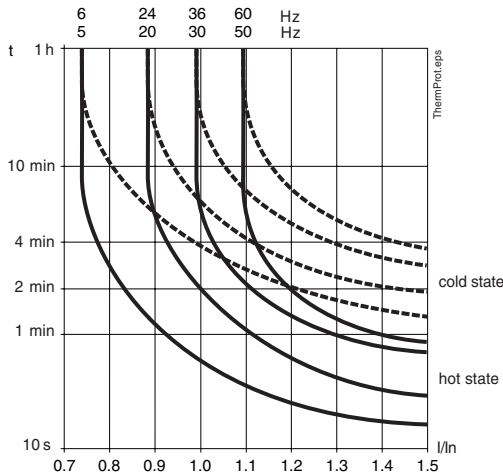

Thermal Protection of Motor

This function provides indirect thermal protection of the motor by continuous calculation of its theoretical temperature rise. The drive controller will be locked on a fault if the calculated temperature rise exceeds 118% of the nominal temperature rise.

For applications using self-cooled or force-cooled motors, the microprocessor calculates the theoretical temperature rise of the motor using the following elements:

- Operating frequency
- Current drawn by the motor
- Operating time
- Maximum ambient temperature of 40 °C (104 °F) around the motor

The following adjustments may be made:

- (230/460 V) 0.20 to 1.15 times the nominal current of the drive controller's constant-torque rating, preset at 1.0
- (575 V) 0.50 to 1.15 times the nominal current of the drive controller's constant-torque rating, preset at 1.0
- Adjust to the nominal current indicated on the motor rating plate.

NOTE: When the drive controller de-energizes, the I²t calculation is saved and the cooling effect is calculated.

This function may also be used for specialized applications. Thermal protection may be customized in the fault configuration menu for:

- Applications with force-cooled motors. See the tripping curves at left for the nominal frequency 50/60 Hz.
- Inhibiting thermal protection in harsh environments where temperatures exceed 40 °C (104 °F) around the motor or where there is a risk of the cooling fins becoming clogged. In these applications, provide direct thermal protection using PTC thermistor probes built into the motor.
- Protection of motor using PTC probes. See "Thermal Protection of ATV28 Controller" below.
- In the case of motors connected in parallel on the same controller, each motor starter must be fitted with a thermal overload relay.

Thermal Protection of ATV28 Controller

This function provides direct thermal protection via a thermistor affixed to the heatsink, thus ensuring component protection even in the case of faulty ventilation or excessive ambient temperature. When an overtemperature condition is sensed, the controller will fault on drive overtemperature.

DRIVE AND MOTOR CONFIGURATION PARAMETERS

Drive and motor configuration parameters can be viewed and modified only when access parameter, COD, is set to 0 (unlocked) or when the access locking switch on the remote keypad display is in the total unlock position (see page 15). These parameters can be modified only when the motor is stopped.

Input Base Frequency

At the first powerup or after a return to factory setting, the input base frequency can be set to 50 Hz or 60 Hz. The proper setting of this parameter is important because it affects many other drive controller functions. In 208/230 V and 400/460 V models this parameter is factory set to 50 Hz. Since 575 V models are only rated for 60 Hz, this parameter will not appear.

Nominal Motor Voltage

This parameter is used to enter the nominal motor voltage given on the motor nameplate.

The factory setting is 230 Vac with a range of 200 to 240 Vac for the ATV28•M2 models. For the ATV28•N4 models, when bFr is set to 60 Hz, the factory setting is 460 Vac with a range of 380 to 500 Vac; when the switch is set to 50 Hz, the nominal motor voltage defaults to 400 Vac with a range of 380 to 500 Vac. The factory setting is 575 Vac with a range of 525 to 575 V for the ATV28•S6 models.

Nominal Motor Frequency

This parameter is used to enter the nominal motor frequency given on the motor nameplate. The factory setting is 60 Hz when bFr is set to 60 Hz. When the switch is set to 50 Hz, the nominal motor frequency defaults to 50 Hz. The range is 40 to 400 Hz.

Auto Tune

This parameter causes the drive controller to auto tune with the connected motor. When Auto Tune is initiated, the drive controller pulses the connected motor, and measures and stores motor stator resistance and conductor resistance. This allows the drive to provide better current regulation for improved motor torque performance.

Automatic Adaptation of the Deceleration Ramp

This function provides automatic adaptation of the deceleration ramp if the programmed ramp setting is too low for the inertia of the load. This prevents possible faulting of the drive controller due to excessive braking. All applications, except those requiring precise stopping and those which use braking resistors, may benefit from this function.

The setting of this function is either Yes or No. The default setting is yes.. Automatic adaptation must be cancelled if the machine has position control with stopping on a ramp and a braking resistor installed.

Maximum Frequency

Maximum Frequency is used as a maximum speed clamp. The High Speed setting cannot be above the Maximum Frequency setting. Maximum Frequency is adjustable from 40 to 400 Hz and factory set to 60 Hz or 72 Hz depending on the 50/60 Hz switch configuration.

Switching Frequency

This function allows configuration of the switching frequency of the drive output transistors. The factory setting is 4 kHz. The range for this parameter is 2 to 15 kHz.

If the drive controller thermal state goes above 95%, the switching frequency selection will drop to 4 kHz. When the thermal state drops to 70%, the switching frequency returns to the set value.

A higher switching frequency will produce a waveform with less harmonic distortion and allow the current regulator in the drive controller to perform better. Cable lengths greater than 330 feet (100 m) may



ALTIVAR® 28 AC Drives

Drive and Motor Configuration Parameters

require adjusting the switching frequency to lower settings to reduce the transmission line phenomena that tends to develop in long conductors.

The switching frequency can be randomly modulated to avoid resonance phenomena in the motor. This feature is useful in applications where audible motor noise is undesirable.

Energy Economizer

This function is enabled when the energy saving for Variable Torque configuration is selected in the Drive menu. When this parameter is enabled, the drive controller optimizes the motor efficiency by automatically adjusting the volts/hertz ratio. The drive controller accelerates the load with a constant volts/hertz ratio. When the reference speed is attained, the drive controller begins lowering the voltage applied until the current begins to rise. It operates at this point until the speed reference is changed. This parameter is useful in all variable torque applications.



DRIVE CONTROL PARAMETERS

Drive control parameters can be viewed and modified only when access parameter, COD, is set to 0 (unlocked) or when the access locking switch on the remote keypad display is in the total unlock position (see page 15). They can be modified only when the motor is stopped.

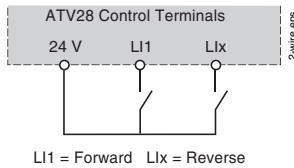

Two Wire Control

Two-Wire Control

The drive controller is factory-configured for two-wire control. The two-wire control function controls operation direction using maintained contacts. Depending on whether one or two directions of operation are required by the application, one or two logic inputs must be assigned to this function. An example of wiring for two-wire control is shown to the left.

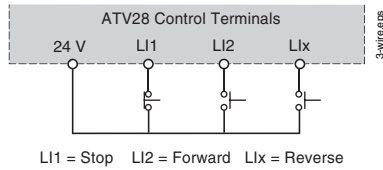

Three Wire Control

Three operating modes are possible:

- Detection of the state of logic inputs
- Detection of a change in the state of logic inputs
- Detection of the state of logic inputs with Forward operation having priority over Reverse operation

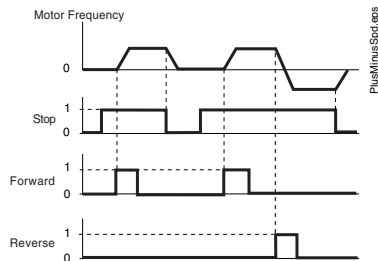

Three Wire Control Timing Diagram

Three-Wire Control

The three-wire control function controls operation and stopping direction using momentary contacts. Depending on whether one or two directions of operation are required by the application, two or three logic inputs must be assigned to this function. An example of wiring for three-wire control is shown to the left. Three-wire control is appropriate for all types of applications with one or two operating directions.

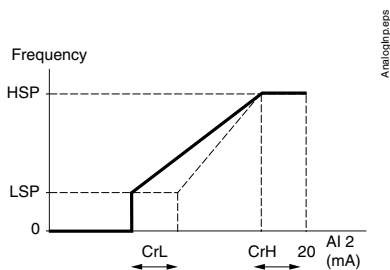

Analog Input Configuration Diagram

Analog Input Configuration

This parameter allows Analog Input 2 (AI2) on the drive controller to be redefined to accept a range of signals. The input can be configured for 0 to 20 mA, 4 to 20 mA, or the minimum value (X) and maximum value (Y) can be user assigned by programming X and Y (with 0.1 mA resolution). Reverse-acting operation can also be configured. For example, 20 to 4 mA, where 20 mA equals low speed and 4mA equals high speed.

Keypad Command

When this parameter is set to Yes, the drive controller can be controlled by the keypad. The factory default is No. Enabling this parameter allows operation of the drive controller with the keypad RUN, STOP/RESET, and FWD/REV keys. In this mode of operation, the speed reference is entered by using the keypad up or down arrow keys. Also, a logic input configured for Freewheel Stop, Fast Stop, or Stop by DC Injection will remain active at the control terminal strip.

Drive Address

This parameter is used to set the address when controlling the drive controller by a MODBUS device via the RS-485 port. The range of addresses is 1 to 31. The factory setting is 1, indicating that the drive controller is not being controlled via the RS-485 port.



ALTIVAR® 28 AC Drives

Configurable I/O Functions and Function Compatibility

CONFIGURABLE I/O FUNCTIONS

Configurable I/O Functions can be viewed and modified only when the access locking switch on the keypad display is in the total unlock position (see page 15). These parameters can be modified only when the motor is stopped.

FUNCTION COMPATIBILITY

The table below shows the I/O functions that are not compatible with each other. Any function not listed in this table is compatible with all other functions.

Aside from the particular functions shown in this table, two general priorities exist:

- Stop functions always have priority over Run commands.
- Speed references via logic command always have priority over analog setpoints.

In addition, the choice of functions is limited by:

- The number of controller inputs and outputs to be re-assigned
- The incompatibility of certain functions with others

	DC injection braking	Summing input	PI regulator	Reference switching	Freewheel stop	Fast stop	JOG operation	Preset speeds
DC injection braking					↑	●		
Summing input			●	●				
PI regulator		●					●	●
Reference switching		●						●
Freewheel stop	←					←		
Fast stop	●				↑			
JOG operation			●					←
Preset speeds			●	●			↑	

- Incompatible functions
- Compatible functions
- N/A

Priority functions (the arrow points to the function that takes priority):

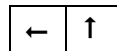

NOTE: Stop functions take priority over run commands. Speed references via logic command take priority over analog references.

ASSIGNMENT OF LOGIC INPUTS (LIX)

The following sections describe the possible assignments of the Logic Inputs (LIx) on the drive controller.

Reverse Operation

A logic input is assigned to reverse the direction of operation. The factory default is for logic input LI2 to be used to reverse operation. To disable this function (for example, when using the controller with a single-direction motor), configure for no assignment or re-assign LI2 to another function.

Alternate Ramp Switching

Alternate ramp switching allows switching between two sets of acceleration and deceleration ramp times, with each set being adjusted separately. A logic input can be assigned to switch between the two sets. A frequency threshold may also be configured for ramp switching; see page 24.

Ramp switching is particularly suited for the following:

- Material handling applications that require smooth starting and approach
- Applications involving fast, steady-state speed correction
- High-speed lathes with limitation of acceleration and deceleration above certain speeds

An example of using a logic input (LI4) to switch between two sets of ramps is shown to the left.

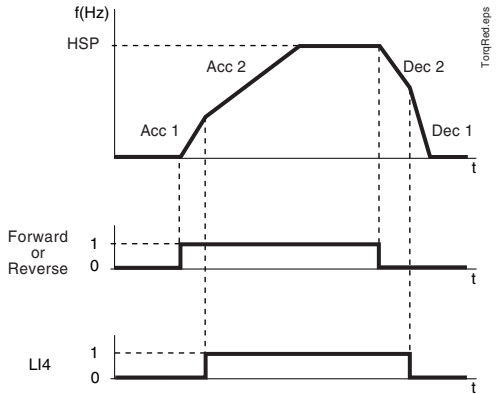

Acceleration 1/Deceleration 1: Adjustment 0.05 to 999.9 s, preset at 3 s
Acceleration 2/Deceleration 2: Adjustment 0.05 to 999.9 s, preset at 5 s

Jog Speed

This function pulses operation with minimum ramp times (0.1 s), limited speed, and minimum time between two pulses. To use this function, assign a logic input to jog. Jog direction is provided by the operating direction command. This function is particularly appropriate for the following applications:

- Machines requiring some manual operation during the process
- Gradual advancement of equipment during a maintenance operation

The graph to the left portrays a typical jogging operation. The speed reference adjusts between 0 and 10 Hz (preset at 10 Hz) and the minimum time (tm) between pulses adjusts from 0 to 2 s (preset at 0.5 s).

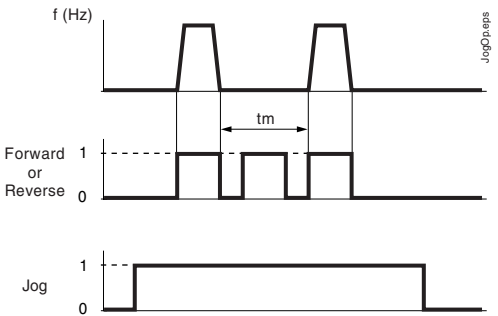

Preset Speeds

The Preset Speeds function allows switching between 2, 4, or 8 preset speeds, and requires 1, 2, or 3 logic inputs respectively. The function is typically used with materials handling and machines with several operating speeds. A typical example involving four speeds is shown to the left.

In this example, four speeds are obtained with inputs LI3 and LI4. At state 0, the speed is LSP or the speed reference depending on the level of analog inputs AI1 and AI2. The preset speeds may be adjusted from 0.1 Hz to the maximum frequency. The factory default settings are:

- 1st Speed: LSP or reference
- 2nd Speed: 5 Hz
- 3rd Speed: 10 Hz
- 4th Speed: HSP

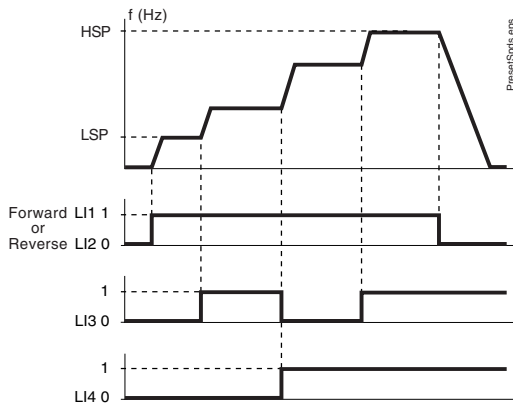

NOTE: To reassign the logic inputs to a function other than Preset Speeds, PS8 (LIz) must be cleared, then PS4 (LIy), then PS2 (LIx).



ALTIVAR® 28 AC Drives

Assignment of Logic Inputs (Lix)

Preset Speed Logic

2 Preset Speeds		4 Preset Speeds			8 Preset Speeds			
Assign Llx to PS2.		Assign Llx to PS2, then Lly to PS4.			Assign Llx to PS2, then Lly to PS4, then Llz to PS8.			
Llx	Speed reference	Lly	Llx	Speed reference	Llz	Lly	Llx	Speed reference
0	LSP + AI reference	0	0	LSP + AI reference	0	0	0	LSP + AI reference
1	HSP	0	1	SP2	0	0	1	SP2
		1	0	SP3	0	1	0	SP3
		1	1	HSP	0	1	1	SP4
					1	0	0	SP5
					1	0	1	SP6
					1	1	0	SP7
					1	1	1	HSP

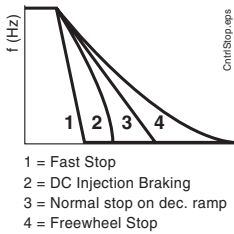

Controlled Stop Functions

The Controlled Stop functions provide alternate stopping methods to the normal drive controller stop. Normally, the drive controller follows the decel ramp on a command to stop. To use the Controlled Stop function, one logic input (LI) must be assigned. The input is active at 0 for a Freewheel Stop or Fast Stop, and is active at 1 for DC Injection Braking. These stop requests always have priority over a normal stop or a Run signal. Three controlled stop methods are available:

- **Freewheel Stop/Run Permissive**
The drive controller output is turned off and the motor coasts to a stop according to the inertia and resistive torque of the load. This method is often used in applications where Run Permissive is used as an electrical safety device.
- **Fast Stop**
Braking with a deceleration ramp time that is four times faster than that set by the standard deceleration parameter (DEC). A successful fast stop depends on the braking torque rating of the motor and on the drive controller's ability to accept energy from the motor. This method is often used for materials handling applications as an emergency stop.
- **DC Injection Braking**
Adjustment of time (0 to 25.5 s, preset at 0.5 s) and current (10% to 100% of nominal controller current in a high-torque application, preset at 70%). It is possible to set continuous braking current from 10% to 100% of nominal motor current (factory setting is 50%). After 25 s, the current automatically goes to 50%. This method is often used for applications involving fans since it eliminates the need for the addition of a braking resistor.
Note that after a stop (frequency less than 0.1 Hz), DC Injection Braking may be combined with the other methods. For this situation, only the current injected after 30 s can be adjusted.

Force Local

This function allows a logic input to be assigned to force local control of the drive controller. Configuration of this function is recommended when using serial communication with the drive controller. This input is typically wired into the Hand and Off positions of a Hand-Off-Auto selector switch when used in conjunction with serial communication with the drive controller. Initiating this input overrides any commands being received over the serial communications link and the drive controller responds to the inputs given at the control terminal block.

Fault Reset

This function allows faults to be reset by a logic input assigned to this function. See page 36 for additional fault reset methods.

ALTIVAR® 28 AC Drives Assignment of Logic Inputs (Lix)

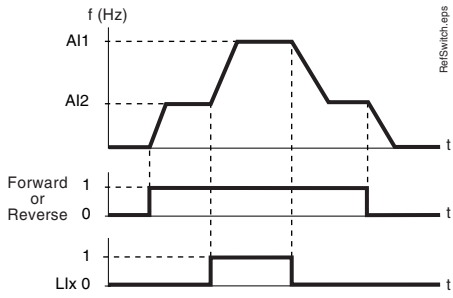

Connection Diagram for Reference Switching

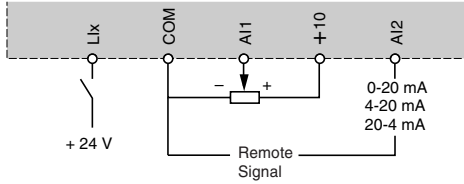

Reference Switching (Auto – Manual)

The Reference switching function permits switching of two analog references by logic command. This function avoids switching of low-level speed reference signals, and enables two reference inputs, AI1 and AI2 (or AIC), to be independent. To use this function, one logic input (LI) must be re-assigned.

This function is typically used for:

- Machines with automatic/manual operation such as pumps
- Automatic control via a sensor on input AI2, validated by the logic input at state 0
- Manual control via potentiometer on input AI1 (local control)

A graphical representation of reference switching and a connection diagram are shown to the left.



ALTIVAR® 28 AC Drives

Assignment of Analog Inputs (AIx)

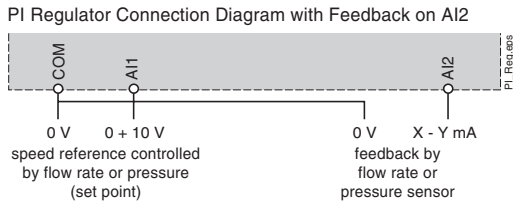
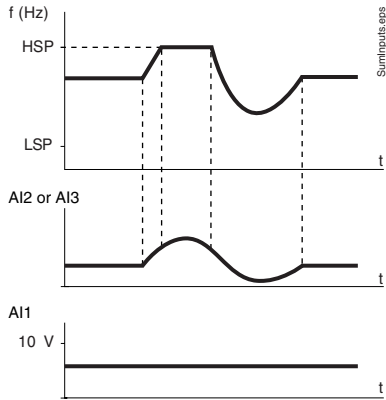

ASSIGNMENT OF ANALOG INPUTS (AIX)

The following sections describe the possible assignments of the Analog Inputs (AIx) on the drive controller and the optional I/O Extension Cards.

Speed Reference Summing

Analog input AI2 (and/or analog input AI3 with an I/O extension card) can be assigned as a summing input for AI1 with peak limiting corresponding to the speed HSP. This is often used for machines whose speed is controlled by a correction signal on input AI2.

The figure to the left provides a graphical depiction of summed references.

PI Regulation

The PI Regulation function provides simple regulation of flow rate or pressure with a sensor sending a feedback signal to the drive controller. This function is often used for pumping and fan applications. Note that the PI Regulation function is not compatible with the Preset Speeds and Jog functions.

To use this function, assign AI1 as the reference and AI2 as feedback. The PI reference signal may also be transmitted via the RS-485 serial link or via one of the communication cards. Typical connection diagrams are shown to the left.

The adjustable parameters for this function are:

- Proportional gain, 0.01 to 100.00
- Integral gain, 0.01 to 100.00 per second
- PI feedback-scaling factor. This parameter permits adjustment of the maximum value of the PI feedback so that it corresponds to the maximum value of the PI regulator speed reference.
- PI inversion parameter. This parameter can be used to invert the response of the drive controller to the feedback signal.
 - If set to NO, the motor speed increases when the difference between the set point signal and the feedback signal is positive.
 - If set to YES the motor speed decreases when the difference between the set point signal and the feedback signal is positive.



ASSIGNMENT OF LOGIC OUTPUT (R2)

The following is a description of the possible assignments of the Logic Output, R2.

Reference Frequency Attained (Speed Attained)

The logic output is high (24 Vdc nominal) if the output motor frequency is equal to the speed reference value.

Frequency Level Attained

The logic output is high (24 Vdc nominal) if the output motor frequency is greater than or equal to the configured frequency level. The frequency level is factory set at 50 or 60 Hz (depending on the setting of bFr) and has an adjustable range of 0 Hz to the high speed setting.

Current Level Attained

The logic output is high (24 Vdc nominal) if the motor current is greater than or equal to the configured current level. The current level is factory set at 150% of the normal current and has an adjustable range of 10% of the motor thermal current, Ith, to 150% of the nominal current.

Motor Thermal Level Attained

The logic output is high (24 Vdc nominal) if the motor thermal state is greater than or equal to the configured motor thermal level. The motor thermal level is factory set at 100% and has an adjustable range of 1 to 118%.

ASSIGNMENT OF ANALOG OUTPUTS

The following sections describe the possible assignments of the Analog Output (AO). The analog output can be selected from 0–20 mA or 4–20 mA.

Motor Current

When configured for motor current, the analog output provides a signal proportional to motor current. The minimum configured value corresponds to zero, while the maximum configured value of the analog output corresponds to twice the nominal motor thermal current, Ith.

Output Frequency

When configured for output frequency, the analog output provides a signal proportional to motor frequency estimated by the drive controller. The minimum configured value corresponds to zero, while the maximum configured value of the analog output corresponds to the maximum frequency setting, not the high speed setting.

Motor Torque

When configured for motor torque, the analog output provides a signal proportional to motor torque as an absolute value. The minimum configured value corresponds to zero, while the maximum configured value of the analog output corresponds to twice the nominal motor torque.

Motor Power

When configured for motor power, the analog output provides a signal proportional to the power supplied by the drive controller. 20 mA corresponds to twice the nominal motor power.



ALTIVAR® 28 AC Drives

Fault Management Parameters

FAULT MANAGEMENT PARAMETERS

The ATV28 drive is equipped with features that are designed to protect the drive controller and motor, and to provide process related information. Understanding the fault management capabilities of the drive controller and determining the proper configuration for the application can enhance the total system installation and performance over the life of the equipment.

The fault messages provided by the drive controller can be divided into three categories:

- Protective faults
These faults are displayed when the drive detects conditions that may damage the drive controller and/or motor. The drive controller shuts down to prevent further damage from occurring.
- Drive faults
These faults are displayed when a problem in the drive needs to be diagnosed.
- Process faults
These faults are displayed when a process signal used by the drive controller is interrupted.

Fault Messages

Protective Faults	Protective Faults (Cont.)	Drive Faults	Process Faults
Input phase loss	Overbraking	EEPROM fault	Serial link failure
Undervoltage	Motor phase loss	Internal fault	
Overvoltage	Overcurrent		
Drive overheating	Motor short circuit		
Motor overload	Motor overheating		

Fault Relay

The fault relay (R1) provides 1 normally open and 1 normally closed contact. The relay is energized when the drive controller is powered up and a fault is not present. This relay cannot be re-assigned. If a fault is detected, the drive controller trips and the fault relay de-energizes.

Resetting a Fault

The drive controller can be reset after a fault by one of three methods:

- Turning power to the drive controller off, waiting for the LEDs to go off, and applying power
- Using the reset button on the keypad or a logic input after assigning to Fault Reset
- By the Automatic Restart function, if configured

Automatic Restart

This function permits automatic restarting after the drive controller detects a fault, provided that the other operating functions are correct, a Run command is present, and the fault has disappeared. The factory setting for this function is NO.

When automatic restart is configured for YES. The fault relay remains energized while attempting to restart. If the controller has not restarted after six attempts, it will display a fault, de-energize the fault relay, and the automatic restart procedure will be abandoned until the controller is switched off and then on again.

When configured for USF, Automatic Restart is only active for the USF fault.



The faults which allow automatic restarting are:

- Excessive braking
- Input mains overvoltage
- Motor thermal overload
- Drive controller thermal overload
- Motor phase loss
- Serial link fault
- Mains voltage is too low (for this fault, the function is always active, even if it has not been configured). In the case of this fault, the controller fault relay remains energized if the function is configured, and the speed reference and the operating direction must be maintained.

Automatic restart is often used in applications where machines or installations are operating continuously or without supervision and which, when restarted, pose no hazard to either equipment or personnel (for example, pumps, fans, etc.).

Fault Reset Type

This function allows faults to be reset by logic input (Llx), which can be re-assigned to this function. The starting conditions after reset are the same as those at a normal power-up.

The following faults may be reset:

- Overvoltage
- Motor phase loss
- Motor overload if thermal state is below 100%
- Drive controller overheating
- Input mains overvoltage
- Serial link fault

The mains undervoltage and mains phase loss faults will reset automatically when the supply returns to normal.

Output Phase Loss

The output phase loss detection can be disabled. Factory setting is enabled.

Input Phase Loss

The input phase loss detection can be disabled on three phase devices. Factory setting is enabled.

Automatic Catch of a Spinning Load (Catch-on-the-fly)

This function, also termed a “flying start,” is active by default (although it is automatically disabled if the Brake Sequence function is configured). It allows the motor to be restarted without a speed surge after one of these events:

- Mains power break or simple switch off
- Fault reset or automatic restart
- Freewheel stop or injection stop with logic input
- Momentary loss of power downstream of drive controller

On restart, the controller searches for the effective speed of the motor in order to restart on a ramp from this speed and return to the reference speed. The speed search time can reach 1 s depending on the initial difference.

This function is often used for applications where the motor speed of a machine does not drop rapidly after a mains power break (machines with high inertia) as well as fans and pumps driven by residual flux.



ALTIVAR® 28 AC Drives

Fault Management Parameters

Controlled Stop on Power Loss

This function can be used to determine how the drive controller will react to a loss of power. Two configurations are possible:

- Disabled

The drive controller immediately faults in response to an input phase loss. This is the factory setting.

- Maintain DC bus voltage

With this configuration, DC bus voltage is maintained as long as possible. The ATV28 drive is designed to ride through power sags and to provide degraded operation down to 60% of nominal line voltage for 500 ms. Longer ride through is possible if there is sufficient kinetic energy generated by the connected motor load inertia. An undervoltage fault appears after the voltage drops below 60% of nominal line voltage. This configuration should be used to maximize the ride through time of the drive controller and to minimize nuisance tripping.



PARAMETER SUMMARY

The following tables show the ATV28 configuration parameters. This page can be copied and used as a worksheet to customize settings for your application.

Settings Menu (SE-) Parameters

Code	Factory Setting	Customer Setting	Code	Factory Setting	Customer Setting
- r P 1 ♦	0.0%	%	- r D t ♦	For	
- R C C ♦	3.0 s	s	- d E C	3.0 s	s
- R C 2	5.0 s	s	- d E 2 ♦	5.0 s	s
- L S P	0.0 Hz	Hz	- H S P	depends on catalog number	Hz
- I t H	depends on catalog number	A	- U F r	20% (115% for 575 V)	%
- S L P	depends on catalog number		- F L G	33%	%
- I d C	depends on catalog number	Hz	- t d C	0.5 s	s
- J P F	0 Hz	Hz	- J D G ♦	10 Hz	Hz
- r P G ♦	1		- r I G ♦	1 /s	/s
- F b S ♦	1		- P I C ♦	no	
- S P 2 ♦	10 Hz	Hz	- S P 3 ♦	15 Hz	Hz
- S P 4 ♦	20 Hz	Hz	- S P 5 ♦	25 Hz	Hz
- S P 6 ♦	30 Hz	Hz	- S P 7 ♦	35 Hz	Hz
- F t d ♦	depends on catalog number	Hz	- t t d ♦	depends on catalog number	A
- t t d ♦	100%	%	- t L S	0.0 s	s

♦ These parameters appear if the corresponding functions have been configured in the Drive or I/O menus.

I/O Menu (I-O-) Parameters

Code	Factory Setting	Customer Setting	Code	Factory Setting	Customer Setting
- t C C	2C		- L I 2	rrS	
- L I 3	PS2		- L I 4	PS4	
- R I C	SAI		- C r L	4 mA	mA
- C r H	20 mA	mA	- R D	rFr	
- R D t	0 mA	mA	- r 2	SrA	
- R d d	1		- b d r	19.2	

Drive Menu (drC-) Parameters

Code	Factory Setting	Customer Setting	Code	Factory Setting	Customer Setting
- U n S	V	V	- F r S	depends on catalog number	Hz
- t U n	no		- t F r	depends on catalog number	Hz
- U F t	n		- b r R	YES	
- F r t	0 Hz	Hz	- S F r	4.0 kHz	kHz
- n r d	YES		- R t r	no	
- D P L	YES		- I P L	YES	
- S t P	no		- F L r	no	
- d r n	no		- S d S	30	



ALTIVAR® 28 AC Drives Installation

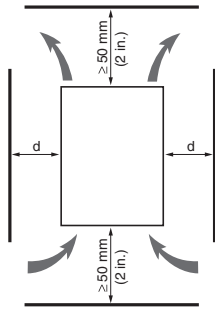

Allow 10 mm (0.4 in.) free space in front of the drive controller.

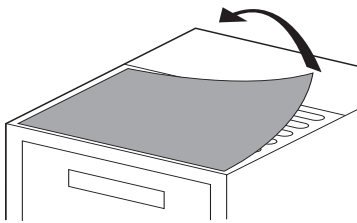

Removing the Vent Cover

INSTALLATION

- The ALTIVAR 28 drive controller must be installed in a suitable environment.
- Install the drive controller vertically $\pm 10^\circ$ with the power terminals at the bottom. Avoid placing the drive controller near any heat sources.
- Mount the drive controller on a flat, solid surface to achieve proper air flow.
- Verify that the voltage and frequency characteristics of the input line match the drive controller nameplate rating.
- Installation of a disconnect switch between the input line and the drive controller should be in accordance with national and local codes.
- Overcurrent protection is required. Install the line power fuses recommended in the tables on page 47.
- Leave sufficient free space around the controller to ensure that the air required for cooling can circulate from the bottom to the top of the unit. See the figures to the left.

Minimum Clearances

- From -10 to 40°C :
For $d \geq 50$ mm (2 in.): No special precautions.
For $0 \leq d < 50$ mm (2 in.) (drive controllers can be mounted side by side): Remove the vent cover from the top of the drive controller, as shown to the left (the degree of protection becomes IP20).
- From 40 to 50°C :
For $d \geq 50$ mm (2 in.): Remove the vent cover from the top of the drive controller, as shown to the left (the degree of protection becomes IP20), or derate the nominal drive controller current by 2.2% for every $^\circ\text{C}$ above 40°C .
For $d < 0$: Remove the vent cover from the top of the drive controller, as shown to the left (the degree of protection becomes IP20), and derate the nominal drive controller current by 2.2% for every $^\circ\text{C}$ above 40°C .
- From 50 to 60°C :
Only for $d \geq 50$ mm (2 in.): Remove the vent cover from the top of the drive controller, as shown to the left (the degree of protection becomes IP20), and derate the nominal drive controller current by 3% for every $^\circ\text{C}$ above 50°C up to 60°C .

NOTE: 575 V drive controllers are not rated to operate above 50°C .

Labels

The drive controller is supplied with four labels. The wiring diagram label comes affixed to the inside of the hinged cover. Three other self-adhesive labels are supplied with the drive controller and stored under the hinged cover. Affix these near the drive controller as required. They are:

- A brief programming description
- A description of the fault codes
- A blank label for recording customer settings

NOTE: Do not place labels on the heatsink or over the ventilating slots on the side of the drive controller.



ATV28 MENU OVERVIEW

SEt—Settings/Adjust Menu

Parameter	Code
Acceleration Ramp	<i>A C C</i>
Deceleration Ramp	<i>d E C</i>
Low Speed	<i>L S P</i>
High Speed	<i>H S P</i>
Motor Therm Current	<i>I t H</i>
IR Compensation	<i>U F r</i>
Slip Compensation	<i>S L P</i>
Freq Loop Gain	<i>F L G</i>
Level of DC Inj Current	<i>l d C</i>
DC Inj Braking Time	<i>t d C</i>
Skip Freq	<i>J P F</i>
Low Speed Dwell Time	<i>t L S</i>
Speed Ref/Remote Keypad	<i>L F r</i>
PI Reference	<i>r P I</i>
Direction of Operation	<i>r O t</i>
2nd Acceleration Ramp	<i>A C 2</i>
2nd Deceleration Ramp	<i>d E 2</i>
Jog	<i>J O G</i>
PI Proportional Gain	<i>r P G</i>
PI Integral Gain	<i>r I G</i>
PI Feedback Scaling	<i>F b S</i>
PI Reverse Acting	<i>P I C</i>
2nd Preset Speed	<i>S P 2</i>
3rd Preset Speed	<i>S P 3</i>
4th Preset Speed	<i>S P 4</i>
5th Preset Speed	<i>S P 5</i>
6th Preset Speed	<i>S P 6</i>
7th Preset Speed	<i>S P 7</i>
Motor Freq Threshold – R2	<i>F t d</i>
Current Threshold – R2	<i>C t d</i>
Motor Therm State Threshold	<i>t t d</i>

Parameters in the shaded rows appear if either the *local control option is present or the corresponding functions have been configured in the drC or I-O- menu.

I-O—I/O Assignment Menu

Parameter	Code
2-Wire/3-Wire Control	<i>t C C</i>
Keypad Command	<i>L C C</i>
LI2 Assign	<i>L I 2</i>
LI3 Assign	<i>L I 3</i>
LI4 Assign	<i>L I 4</i>
Not Assigned	<i>n O</i>
Reverse	<i>r r S</i>
Ramp Switching	<i>r P 2</i>
Jog Operation	<i>J O G</i>
2 Preset Speeds	<i>P S 2</i>
4 Preset Speeds	<i>P S 4</i>
8 Preset Speeds	<i>P S 8</i>
Freewheel Stop	<i>n S t</i>
DC Inj Braking	<i>d C I</i>
Fast Stop	<i>F S t</i>
Forced Local	<i>F L O</i>
Fault Reset	<i>r S t</i>
Reference Switching	<i>r F C</i>
Analog Input AIC/AI2	<i>A I C</i>
Not Assigned	<i>n O</i>
Summing with AI1	<i>S A I</i>
PI Feedback Internal	<i>P I I</i>
PI Feedback Auto	<i>P I A</i>
Min Value AIC	<i>C r L</i>
Max Value AIC	<i>C r H</i>
Analog Output	<i>A O</i>
Not Assigned	<i>n O</i>
Motor Current	<i>O C r</i>
Motor Freq	<i>r F r</i>
Motor Torque	<i>O L O</i>
Power	<i>O P r</i>
Analog Output 0–20/4–20	<i>A O t</i>
Relay R2	<i>r 2</i>
Not Assigned	<i>n O</i>
Freq Threshold Att	<i>F t A</i>
Current Thresh Att	<i>C t A</i>
Speed Ref Att	<i>S r A</i>
Thermal Thresh Att	<i>t S A</i>
Drive Address	<i>A d d</i>
Serial Link Baud Rate	<i>b d r</i>

SUP—Display Menu

Parameter	Code
Frequency Ref	<i>F r H</i>
Output Frequency	<i>r F r</i>
Speed	<i>S P d</i>
Motor Current	<i>L C r</i>
Power	<i>O P r</i>
Line Voltage	<i>U L n</i>
Motor Thermal State	<i>t H r</i>
Drive Thermal State	<i>t H d</i>
Last Fault	<i>L F t</i>
Software Version	<i>C P U</i>
Access Code	<i>C O d</i>
Drive Status	<i>- - -</i>
Initialization	<i>I n I t</i>
Ready	<i>r d Y</i>
Freq Ref	<i>4 3. 0</i>
DC Inj Braking	<i>d c b</i>
Freewheel Stop	<i>n S t</i>
Fast Stop	<i>F S t</i>

drC—Drive Config Menu

Parameter	Code
Nominal Motor Voltage	<i>U n S</i>
Nominal Motor Freq	<i>F r S</i>
Auto-tuning	<i>t U n</i>
Max Output Freq	<i>t F r</i>
V/Hz Ratio	<i>U F t</i>
Decel Ramp Adaptation	<i>b r A</i>
Ramp Switching Freq	<i>F r t</i>
Switching Freq	<i>S F r</i>
Noise Reduction	<i>n r d</i>
Automatic Restart	<i>A t r</i>
Motor Phase Failure Fault	<i>O P L</i>
Line Supply Phase Failure	<i>I P L</i>
Controlled Stop	<i>S t P</i>
Smooth Restart	<i>F L r</i>
Low Tripping Thresh. USF	<i>d r n</i>
Scale Factor for SPd	<i>S d S</i>
Factory Settings	<i>F C S</i>

For a diagram of how to use the Menus, see page 13.



MOUNTING IN A TYPE 12 (OR IP54) METAL ENCLOSURE

Calculating Enclosure Size

The equation for calculating Rth (°C/W), the maximum allowable thermal resistance of the enclosure is as follows:

$$R_{th} = \frac{T_i - T_o}{P}$$

T_i = Max. internal ambient temp. (°C) around the controller
 T_o = Max. external ambient temp. (°C) around enclosure
 P = Total power dissipated in enclosure (W)

For the power dissipated by the drive controllers at rated load, see page 9.

Useful heat exchange surface area, S (in²), of a wall-mounted enclosure generally consists of the sides, top, and front. The minimum surface area required for a drive controller enclosure is calculated as follows:

NOTE: Contact the enclosure manufacturer for K factors.

$$S = \frac{K}{R_{th}}$$

Rth = Thermal resistance of the enclosure (calculated previously)
K = Thermal resistance per square inch of the enclosure.

Consider the following points when sizing the enclosure:

- Use only metallic enclosures, since they have good thermal conduction.
- This procedure does not consider radiant or convected heat load from external sources. Do not install enclosures where external heat sources (such as direct sunlight) can add to enclosure heat load.
- If additional devices are present inside the enclosure, consider the heat load of the devices in the calculation.
- The actual useful area for convection cooling of the enclosure will vary depending upon the method of mounting. The method of mounting must allow for free air movement over all surfaces considered for convection cooling.

The following sample illustrates calculation of the enclosure size for an ATV28HU72N4U (5 hp) drive controller mounted in a Type 12 or IP54 enclosure.

- Maximum external temperature: $T_o = 25\text{ °C}$
- Power dissipated inside enclosure: $P = 131\text{ W}$
- Maximum internal temperature: $T_i = 40\text{ °C}$
- Thermal resistance per square inch of enclosure: $K = 186$
- Calculate maximum allowable thermal resistance, Rth:

$$R_{th} = \frac{40\text{ °C} - 25\text{ °C}}{131\text{ W}} = 0.115\text{ °C/W}$$

- Calculate minimum useful heat exchange surface area, S:

$$S = \frac{186}{0.115} = 1624.4\text{ in}^2$$



Useful heat exchange surface area (S) of the proposed wall-mounted enclosure:

- Height: 28 in (711 mm)
- Width: 24 in (610 mm)
- Depth: 12 in (305 mm)

$$\begin{array}{ccc} \text{front area} & \text{top area} & \text{side area} \\ \downarrow & \downarrow & \downarrow \\ S = (24 \times 28) + (24 \times 12) + 2(28 \times 12) = 1632 \text{ in}^2 \end{array}$$

If the selected enclosure does not provide the required surface area or does not meet application needs, consider the following:

- Use a larger enclosure.
- Add a passive heat exchanger to the enclosure.
- Add an air conditioning unit to the enclosure.

Ventilation

When mounting the drive controller inside a Type 12 or IP54 enclosure, follow these ventilation precautions:

- Observe minimum clearance distances shown on page 40.
- Follow the installation precautions on page 40.
- A stirring fan with filter may be necessary to circulate the air inside the enclosure and prevent hot spots in the drive controller and to distribute the heat uniformly to surfaces used for convection cooling.

If there is a possibility of condensation, keep the drive controller powered up during periods when the motor is not running or install thermostatically controlled strip heaters.



ALTIVAR® 28 AC Drives

Wiring Recommendations

WIRING RECOMMENDATIONS

Follow the practices below to reduce the possibility of coupling electrical transients from power circuits into control circuits or from motor power wiring into other power circuits:

- Separate control circuit wiring from all power wiring.
- Separate motor wiring and other power conductors as much as possible, whether from the same drive controller or other drive controllers.
- Do not run control circuit wiring in the same conduit as power wiring.
- Do not run multiple sets of power wiring in the same conduit.

Follow the practices below when wiring enclosed ATV28 drive controllers:

- When using metallic conduit, use metal conduit entrance kits; see page 53 for a list of conduit kits.
- Use metallic conduit for all controller wiring. Do not run control and power wiring in the same conduit.
- Separate metallic conduits carrying power wiring or low-level control wiring by at least 3 in. (76 mm).
- Separate non-metallic conduits or cable trays used to carry power wiring from metallic conduit carrying low-level control wiring by at least 12 in. (305 mm).
- Whenever power and control wiring cross, the metallic conduits and non-metallic conduits or trays must cross at right angles.
- Equip all inductive circuits near the drive (relays, contactors, solenoid valves) with noise suppressors or connect them to a separate circuit.

Branch Circuit Connections

Refer to NEC Article 430 and local codes for sizing of branch circuit conductors. Ensure that all branch circuit components and equipment (such as transformers, feeder cables, disconnect devices, and protective devices) are rated for the input current of the ATV28 drive controller, or for the rated output current, whichever value is larger. The input current of the controller depends on the impedance of the power distribution system and the available fault current at the drive input terminals.

Select the input current corresponding to the available fault current capability or the line impedance present. If the branch circuit available fault current capability is limited by fuses or circuit breakers (not system impedance), use the available fault current capability on the line side of the fuses or circuit breakers to select the drive controller input current. Tables 1–4 on pages 11–13 provide input current information to optimally size branch circuit conductors.

NOTE: Ensure that the branch circuit feeder protection rating is not less than the rated output current of the drive controller.

Installation of line reactors with a minimum impedance of 3% is required for all 575 V drive controllers.

When more than two drive controllers are installed in parallel on a common power line voltage, regardless of voltage rating, an individual line reactor per drive controller is recommended. This provides filtering between controllers and reduces harmonic distortion when the system is partially loaded.

When using a line contactor to start the drive controller from line power, limit operations of the line contactor to less than once per minute to avoid premature failure of the filter capacitors and precharge resistors. The preferred method of control is to use inputs LI1 to LI4. This is vital for cycles less than 60 seconds; otherwise the load resistor may be damaged.



Line Reactors

Line reactors can improve protection against line overvoltage surges and reduce input currents to the drive controller by adding impedance. The additional impedance can also reduce the harmonic current distortion produced by the drive controller. Additional impedance is recommended when the impedance of the power distribution system is low, such as when the power of the system transformer is ten times larger than the power rating of the drive controller. Single-phase line reactors can be used for single-phase input rated ATV28 drive controllers. A 3% line reactor is required on all 575 V drive installations (see page 54 for selection).

Output Wiring Precautions

The drive controller is sensitive to the amount of capacitance (either phase-to-phase or phase-to-ground) present on the output power conductors. Excessive capacitance can cause an overcurrent trip. Follow these guidelines when selecting output cable:

- Cable type: The cable selected must have a low capacitance phase-to-phase and phase-to-ground. Do not use mineral-impregnated cable because it has a very high capacitance. Immersion of cables in water increases capacitance.
- Cable length: The longer the cable, the greater the capacitance. Cable lengths greater than 100 ft (30.5 m) can affect controller and motor performance.
- A load filter is recommended on all 575 V applications, especially when the motor leads exceed 40 ft (12 m).
- Proximity to other output cables: Because of high frequency switching and increased capacitance, the drive controller may fault under some conditions.
- **Do not use lightning arrestors and/or power factor correction capacitors on the output of the drive controller.**

Provide at least 20 in. (500 mm) of cable at the drive controller output (U, V, W) to ensure a minimum inductance to protect the drive controller output from short circuits.

Motor Protecting Output Filters

The motor protecting output filters combine inductance, capacitance, and resistance to form a low pass filter. This filter will lower the dv/dt levels to prevent exciting the natural resonant wire frequency of the motor cables. Motors compliant to NEMA MG1, Part 31 may reduce the need for motor protecting filters.

Grounding

For safe, dependable operation, ground the drive controller according to National Electrical Code and all local codes. To ground the drive controller:

- Connect a copper wire from the ground terminal on the drive controller (see the terminal locations in instruction bulletin VVDED399062US) to the power system ground conductor. Wire size is determined by the drive controller size and by national and local codes.
- Verify that resistance to ground is one ohm or less. Improper grounding causes intermittent and unreliable operation.

Ground multiple drive controllers as shown in the figure to the left. Use one grounding conductor per device. Do not loop ground conductors or install them in series.

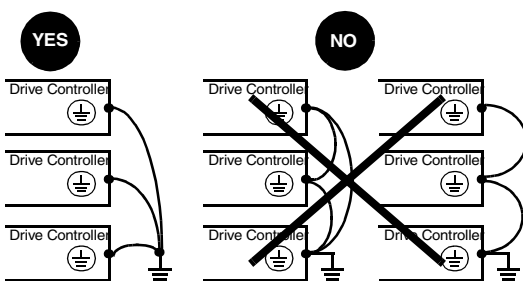

ALTIVAR® 28 AC Drives Wiring Recommendations

Wiring Diagram

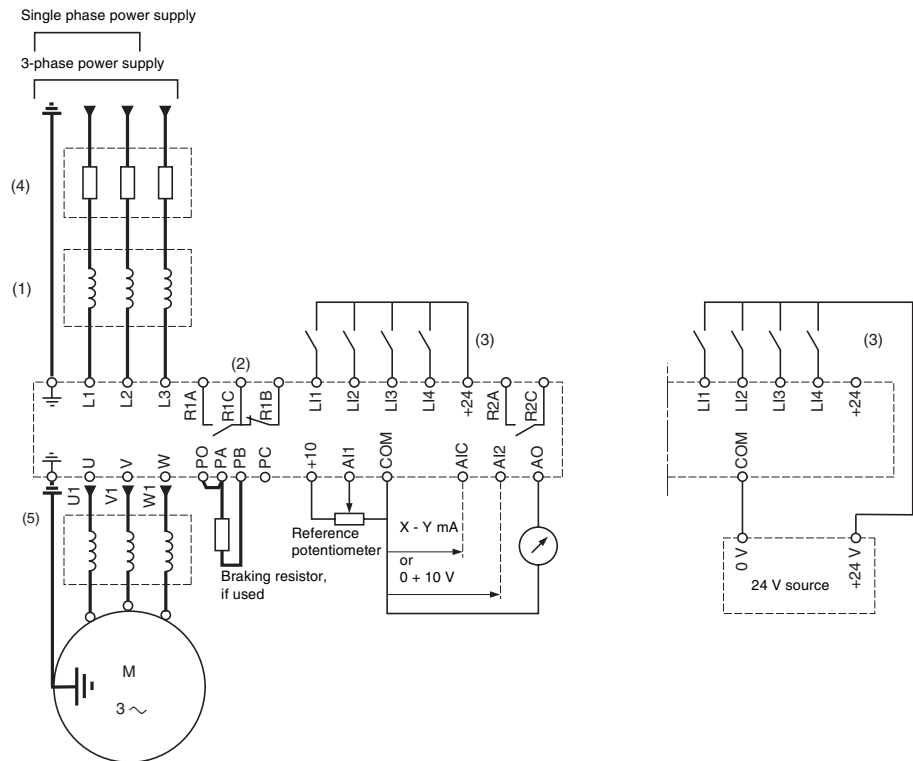

NOTE: Equip all inductive circuits near the drive controller (relays, contactors, solenoid valves) with noise suppressors or connect them to a separate circuit.

- (1) Line reactor, if used. All 575 V installations must include a line reactor (see page 54 for selection).
- (2) Fault relay contacts for remote indication of the drive controller status.
- (3) Internal +24 Vdc. If an external +24 Vdc source is used, connect 0V/Common from that source to the COM terminal, and do not use the +24 terminal on the drive controller.
- (4) Place fuses here. Refer to "Recommended Fuses" on page 47.
- (5) Installation of a load filter is recommended for all 575 V installations. See page 45.



RECOMMENDED FUSES

Recommended Fuses for 230 V Drive Controllers

Motor		Drive Controller ATV28H*****	Fuses (all 600 V)	
kW	hp		Class CC	Class J ▲
0.37	0.5	U09M2U	10 A	10 A
0.75	1	U18M2U	15 A	15 A
1.5	2	U29M2U	20 A	20 A
2.2	3	U41M2U	30 A	30 A
3	—	U54M2U	25 A	25 A
4	5	U72M2U	30 A	30 A
5.5	7.5	U90M2U	—	50 A
7.5	10	D12M2U	—	60 A

▲ Either fast acting or time delay Class J fuses can be used.

Recommended Fuses for 460 V Drive Controllers

Motor		Drive Controller ATV28H*****	Fuses (all 600 V)	
kW	hp		Class CC	Class J ▲
0.75	1	U18N4U	5 A	5 A
1.5	2	U29N4U	10 A	10 A
2.2	3	U41N4U	10 A	10 A
3	—	U54N4U	15 A	15 A
4	5	U72N4U	15 A	15 A
5.5	7.5	U90N4U	30 A	30 A
7.5	10	D12N4U	—	35 A
11	15	D16N4U	—	50 A
15	20	D23N4U	—	60 A

▲ Either fast acting or time delay Class J fuses can be used.

Recommended Fuses for 575 V Drive Controllers

Motor		Drive Controller ATV28H*****	Fuses (all 600 V)	
kW	hp		Class CC	Class J
0.75	1	U18S6XU	2 A	2 A
1.5	2	U29S6XU	3 A	3 A
2.2	3	U41S6XU	5 A	5 A
4	5	U72S6XU	8 A	8 A
5.5	7.5	U90S6XU	10 A	10 A
7.5	10	D12S6XU	—	15 A
11	15	D16S6XU	—	20 A
15	20	D23S6XU	—	25 A



ALTIVAR® 28 AC Drives

Specifications

SPECIFICATIONS

Environmental Specifications

Degree of Protection	Open. Controller electrical creepage distances are designed for use in a pollution degree 2 environment per UL 840. UL Type 1 (230 V/460 V units only) without removal of the protective vent cover from the top of the controller and with the addition of the Conduit Entry Kit (see page 18). IP20 when the vent cover is removed from the top of the controller (see page 40).
Resistance to vibrations	1 g from 13 to 150 Hz
Pollution degree	Pollution degree 2 according to UL 840. Protect the drive controller against dust, corrosive gas, and falling liquid.
Maximum relative humidity	93% maximum, non-condensing and without dripping (provide heating system if there is condensation)
Maximum ambient temperature	Storage: -13 to +158 °F (-25 to +70 °C) Operation: +14 to +104 °F (-10 to +40 °C) without vent cover removed +14 to +122 °F (-10 to +50 °C) with vent cover removed
Altitude	Up to 3,300 ft (1,000 m) without derating; derate by 1% for each additional 330 ft (100 m)

Electrical Specifications

Input voltage	ATV28***M2U (1 phase):208 V -15% to 240 V +10% ATV28***M2U (3 phase):208 V -15% to 230 V +10% ATV28***N4U:400 V -15% to 460 V +15% ATV28***S6XU:575 V ±15%
Input frequency	50/60 Hz ±5% (60 Hz only for 575 V)
Input phases	ATV28HU09M2U to HU41M2U: 1 ATV28HU54M2U to HD12M2U: 3 ATV28***N4U: 3 ATV28***S6XU: 3
Output voltage	Maximum voltage equal to input voltage
Output frequency	0.5 to 400 Hz
Output phases	3
Max. transient current	Up to 150% of nominal drive controller current for 60 seconds (see tables on page 9)
Braking torque	30% of nominal motor torque without dynamic braking (typical value). Up to 150% with optional dynamic braking resistor.
Frequency resolution	Display: 0.1 Hz Analog inputs: 0.1 Hz for 100 Hz maximum
Switching frequency	Adjustable from 2.0 to 15 kHz
Drive controller protection	Galvanic isolation between power and control (power supplies, inputs, outputs) Protection against short circuits: <ul style="list-style-type: none"> • within internal power supplies • between output phases • between output phases and ground for 7.5 to 20 hp drive controllers Thermal protection against overheating and overcurrents Undervoltage and overvoltage faults Overbraking fault
Motor protection	Thermal protection integrated in the drive controller by I ² t calculation Protection against motor phase loss
Codes and standards	UL Listed per UL 508C as incorporating electronic overload protection: UL File E164874 CCN NMMS CSA Certified to CSA C22.2 No. 14 (except for 575 V models) CSA File LR96921 Class 3211 06 CE Marked (except for 575 V models) Conforms to applicable NEMA ICS, NFPA, IEC, and ISO 9001 standards 575 V controllers are cUL Listed



DIMENSIONS AND WEIGHTS

ATV28 Drives

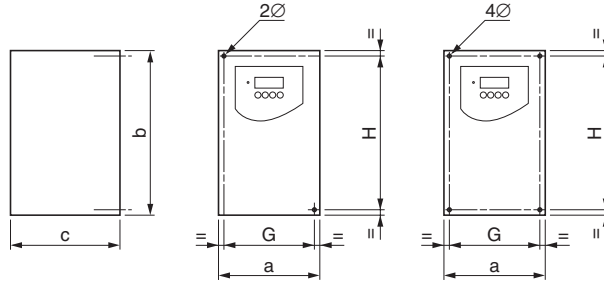

ATV28H****	a		b		c		G		H		2 Ø		4 Ø		Weight	
	mm	in.	mm	in.	mm	in.	mm	in.	mm	in.	mm	in.	mm	in.	kg	lb
U09M2U, U18M2U	105	4.2	130	5.2	140	5.6	93	3.7	118	4.7	5	0.20	—	—	1.8	4.0
U29M2U, U18N4U, U29N4U, U18S6XU, U29S6XU	130	5.2	150	6	150	6	118	4.7	138	5.5	—	—	5	0.20	2.5	5.5
U41M2U, U54M2U, U72M2U, U41N4U, U54N4U, U72N4U, U41S6XU, U72S6XU	140	5.6	195	7.8	163	6.5	126	5.0	182	7.3	—	—	5	0.20	3.8	8.4
U90M2U, D12M2U, U90N4U, D12N4U, U90S6XU, D12S6XU	200	8	270	10.8	170	6.8	180	7.2	255	10.2	—	—	6	0.24	6.1	13.5
D16N4U, D23N4U, D16S6XU, D23S6XU	245	9.8	330	13.2	195	7.8	225	9	315	12.6	—	—	6	0.24	9.6	21.2

EMC Plate

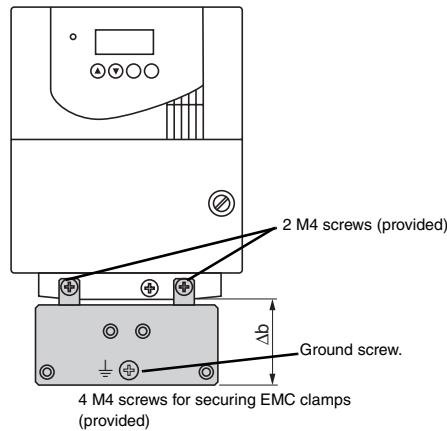

Frame Sizes	ATV28H****	Δb	
		mm	in.
1-3	U09M2U, U18M2U, U29M2U, U41M2U, U54M2U, U72M2U, U18N4U, U29N4U, U41N4U, U54N4U, U72N4U, U18S6XU, U29S6XU, U41S6XU, U72S6XU	48	1.9
4-5	U90M2U, D12M2U, U90N4U, D12N4U, D16N4U, D23N4U, U90S6XU, D12S6XU, D16S6XU, D23S6XU	79	3.2



ALTIVAR® 28 AC Drives

Dimensions and Weights

Conduit Kits (Size 1–5)

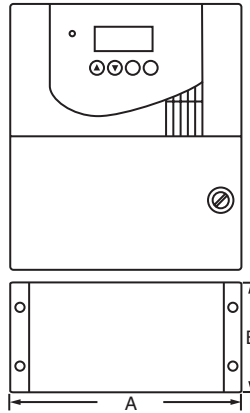

Frame Size	A		B	
	mm	in.	mm	in.
1	106.0	4.17	68.5	2.70
2	123.5	4.86	68.5	2.70
3	132.5	5.22	67.5	2.66
4	200.0	7.87	77.47	3.05
5	244.8	9.64	74.5	2.93

RFI Input Filters

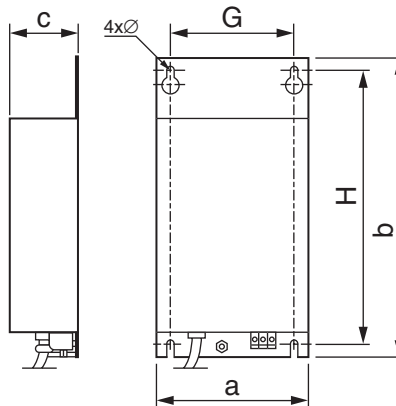

Part Number	a		b		c		G		H		Ø	
	mm	in.	mm	in.	mm	in.	mm	in.	mm	in.	mm	in.
VW3A28401	105	4.11	185	7.28	50	1.96	85	3.35	170	6.69	4	0.16
VW3A28402, VW3A28403	130	5.09	205	8.07	60	2.35	110	4.33	190	7.48	4	0.16
VW3A28404, VW3A28405	140	5.48	250	9.85	60	2.35	120	4.73	230	9.06	4	0.16
VW3A28406	200	7.83	351	13.82	60	2.35	160	6.30	330	13.0	5	0.20
VW3A28407	245	9.60	425	16.73	60	2.35	205	8.07	360	14.17	5	0.20



Keypad Remote Mount Dimensions

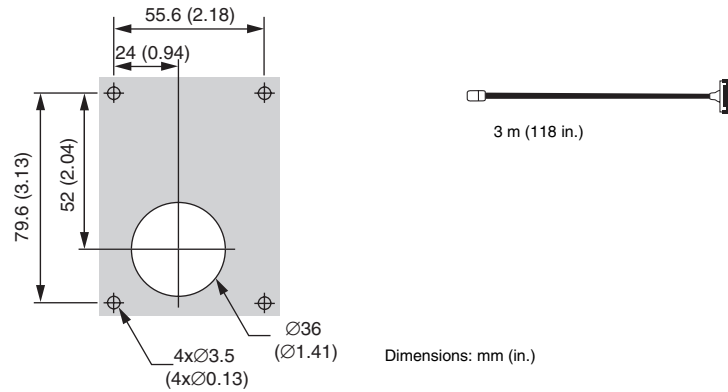

Dynamic Braking Resistor Kit Wall Mounting Dimensions

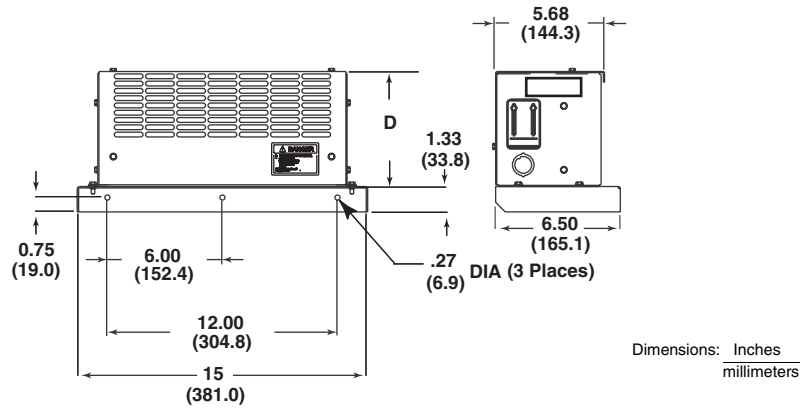

Part Number	D	
	in.	mm
VW3A366711 and VW3A66712	6.00	152.4
VW3A366713 and VW3A66714	9.00	228.6



ALTIVAR® 28 AC Drives Dimensions and Weights

Dimensions for Line Reactor for 575 V Drive Controllers

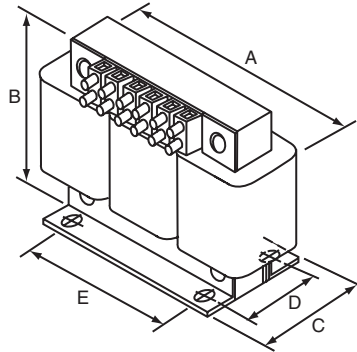

Open Type

Part Number	A		B		C		D		E		Weight	
	mm	in.	mm	in.	mm	in.	mm	in.	mm	in.	kg	lb
RL00202	112	4.4	102	4.0	74	2.9	50	2.0	36	1.44	1.8	4
RL00403	112	4.4	102	4.0	79	3.1	54	2.1	36	1.44	1.8	5
RL00802	152	6.0	122	4.8	79	3.1	54	2.1	50	2.0	3.2	8
RL00803	152	6.0	122	4.8	86	3.4	63	2.5	50	2.0	5.0	11
RL01202	152	6.0	122	4.8	79	3.1	54	2.1	50	2.0	4.5	10
RL01802	152	6.0	122	4.8	86	3.4	63	2.5	50	2.0	5.4	12
RL02502	183	7.2	142	5.6	86	3.4	60	2.3	76	3.0	6.3	14

For line reactors mounted in a cabinet the next to last digit in the part number changes from 0 to 1.

Installed in NEMA 1 Cabinets

Part Number	Cabinet Type	Width		Height		Depth		Cabinet Weight Only	
		mm	in.	mm	in.	mm	in.	kg	lb
RL00212, RL00413, RL00812, RL00813, RL01212, RL01812	Wall mount	203	8	203	8	152	6	3.2	7
RL02512	Floor	330	13	381	15	330	13	14.0	31

ALTIVAR 28 Selection

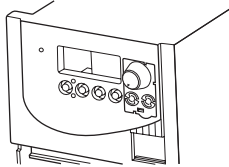
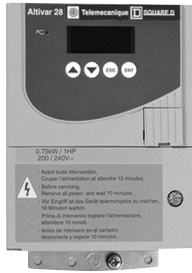

Local Operator Kit

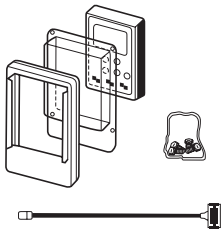

Keypad Remote Mount Kit

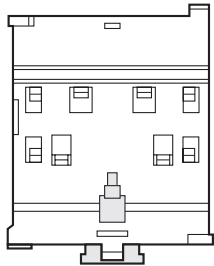

DIN Rail Mount Kit

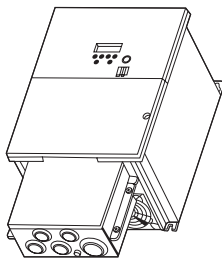

Conduit Entrance Kit

Input Line Voltage 50/60 Hz +/- 5% (Volts)	Three Phase Motor Power ●		Continuous Output Current ▼ (Amperes)	Catalog Number
	kW	HP		
208 - 15% to 230 + 10% Single Phase	0.37	0.5	3.3	ATV28HU09M2U
	0.75	1	4.8	ATV28HU18M2U
	1.5	2	7.8	ATV28HU29M2U
	2.2	3	11	ATV28HU41M2U
208 - 15% to 230 + 10% Three Phase	3	—	13.7	ATV28HU54M2U
	4	5	17.5	ATV28HU72M2U
	5.5	7.5	27.5	ATV28HU90M2U
	7.5	10	33	ATV28HD12M2U
400 - 15% to 460 + 10% Three Phase	0.75	1	2.3	ATV28HU18N4U
	1.5	2	4.1	ATV28HU29N4U
	2.2	3	5.5	ATV28HU41N4U
	3	—	7.1	ATV28HU54N4U
	4	5	9.5	ATV28HU72N4U
	5.5	7.5	14.3	ATV28HU90N4U
	7.5	10	17	ATV28HD12N4U
	11	15	27.7	ATV28HD16N4U
15	20	33	ATV28HD23N4U	
575 ± 15% Three Phase	0.75	1	1.7	ATV28HU18S6XU
	1.5	2	2.7	ATV28HU29S6XU
	2.2	3	3.9	ATV28HU41S6XU
	4	5	6.1	ATV28HU72S6XU
	5.5	7.5	9.0	ATV28HU90S6XU
	7.5	10	11.0	ATV28HD12S6XU
	11	15	17.0	ATV28HD16S6XU
15	20	22.0	ATV28HD23S6XU	

- These power ratings are for a maximum ATV28 switching frequency of 4 kHz in continuous operation.
- ▼ Rated output currents shown are for ATV28 switching frequencies between 2 to 4 kHz. Above 4 kHz and up to 12 kHz, derate continuous output current by 10%. Above 12 kHz, derate current by 20%.

Options — Field Installed Kits

Description	For Drives ATV28H*****	Catalog Number
Start/Stop/Potentiometer Kit Replaces ATV28 keypad display with the addition of a speed potentiometer and run/stop controls	ATV28 all ranges	VW3A28100
Keypad Remote Mount Kit Includes keypad, remote mount hardware, and 3 meter cable. IP65 rated	ATV28 all ranges	VW3A28101
Pocket PC Powersuite Pak Includes an HP JORNADA 545 pocket PC with AC charger, serial cable, stylus pen, carrying case, Powersuite software (VW3A8104), and connection kit (VW3A8111).	ATV28 all ranges	VW3A8108US
Compact Flash Modules Loaded with Powersuite software, for use with the HP JORNADA 520 and 540 series pocket PCs.	ATV28 all ranges	VW3A8110
Pocket PC Connection Kit For connection of an HP JORNADA 520 or 540 series pocket PC to an ATV28 or ATV58 controller. Includes a 0.5 m cable, RS-232 to RS-485 adapter, and an RJ45 to DB9 adapter for use with the ATV58 controller.	ATV28 all ranges	VW3A8111
MODBUS Communications Kit Includes register mapping guide and 3 meter cable with 9-pin SUB-D connector	ATV28 all ranges	VW3A28301U
MAGELiS Terminal This user interface terminal is used in conjunction with MODBUS RS-485 communication kits (VW3A28301U and VW3A58306U, not included) and a tap (TSXSCA62, not included). A cable (XGTZ908) is included.	ATV28 all ranges	XBTHM017010AA8
Powersuite Test and Commissioning Software Kit Software on CD-ROM (cable not included)	ATV28 all ranges	VW3A8104
PC Cable for Test and Commissioning Software	ATV28 all ranges	VW3A8106
DIN Rail Mount Kit	U09M2U – U18M2U	VW3A28851
Conduit Entrance Kit Multiple knockout sizes Installation of conduit entrance kit and retention of vent cover on top of drive controller provides 230/460 V ATV28 with Type 1 rating.	U09M2U, U18M2U U29M2U, U18N4U, U29N4U U41N4U, U54N4U, U72N4U, U41M2U, U54M2U, U72M2U U90M2U, D12M2U, D12N4U, U90N4U D16N4U, D23N4U	VW3A28811A VW3A28812A VW3A28813A VW3A28813A VW3A28814A VW3A28814A VW3A28815



Options — Field Installed Kits (Continued)

Description	For Drives ATV28H*****	Catalog Number
<p>ATV18 Replacement Kit This kit contains two brackets that adapt the spacing of the ATV28 mounting holes to be equivalent to that of the ATV18. This will permit the ATV28 to be secured to the panel holes and mounting hardware already in place for the ATV18.</p>	<p>U09M2U, U18M2U U29M2U, U18N4U, U29N4U U41N4U, U54N4U, U72N4U, U41M2U, U54M2U, U72M2U U90M2U, D12M2U, D12N4U, U90N4U D16N4U, D23N4U</p>	<p>VW3A28821A VW3A28822 VW3A28823 VW3A28823 VW3A28824 VW3A28825</p>
<p>Dynamic Braking Resistor Kit DB resistors are provided in a NEMA Type 1 enclosure and are thermally protected</p>	<p>U09M2U, U18N4U – U72N4U U18M2U – U41M2U, U90N4U – D12N4U U54M2U – U72M2U, D16N4U – D23N4U U90M2U – D12M2U</p>	<p>VW3A66711 VW3A66712 VW3A66713 VW3A66714</p>
<p>RFI Input Filter For compliance with European (CE) conducted emissions standard 55022 Class B (Class A filter built into ATV28 drive)</p>	<p>U09M2U – U18M2U U29M2U U18N4U – U29N4U U41M2U U54M2U – U72M2U, U41N4U – U72N4U U90M2U – D12M2U, U90N4U – D12N4U D16N4 – D23N4U</p>	<p>VW3A28401 VW3A28402 VW3A28403 VW3A28404 VW3A28405 VW3A28406 VW3A28407</p>
<p>Line Reactors for 575 V controllers Open Style</p>	<p>U18S6XU U29S6XU, U41S6XU U72S6XU U90S6XU D12S6XU D16S6XU D23S6XU</p>	<p>RL00202 RL00403 RL00803 RL00802 RL01202 RL01802 RL02502</p>
<p>Line Reactors for 575 V controllers Enclosed (NEMA)</p>	<p>U18S6XU U29S6XU, U41S6XU U72S6XU U90S6XU D12S6XU D16S6XU D23S6XU</p>	<p>RL00212 RL00413 RL00813 RL00812 RL01212 RL01812 RL02512</p>



SUPPORT

Customer Information Center

Now there's one toll-free number to call to get all the information you need. The Square D Customer Information Center (CIC) is a single point of contact where qualified personnel answer your customer service and technical support questions.

The Customer Information Center serves all Square D authorized distributors and customers in the U.S.

Monday–Friday 8:00 a.m.–8:00 p.m. EST

Telephone: 1-888-SQUARED
(1-888-778-2733)

Field Services

We can provide a total service solution for any manufacturer's equipment.

Engineering Services

- Custom-engineered solutions

New Product Services

- Ensure trouble-free start-up

Maintenance Services

- Improve equipment reliability

Retrofit and Upgrade Services

- Extend equipment life

Services available throughout the U.S. and Canada, anytime, day or night.

Telephone: 1-800-634-2003

Conditions of Sale

Refer to the inside cover of the Square D Digest.

D-FAX Fax-On-Demand Service

The Square D fax-on-demand service provides access to information when you need it. The automated voice attendant will guide you through the process and you will receive the information on your fax machine within minutes.

Telephone: 800-557-4556

Customer Literature Center

To obtain support literature for your product or application needs, contact the Square D Customer Literature Center.

Telephone: 800-392-8781

Fax: 800-824-7151

Square D Website

Visit the virtual work zone at the Square D website. It offers a variety of solutions for your drive applications. It also includes software tools, new product information, and product selection information.

Web Address: <http://www.squared.com>



Square D Company
8001 Highway 64 East
Knightdale, NC 27545
1-888-SquareD
(1-888-778-2733)
www.SquareD.com

Schneider Canada Inc.
19 Waterman Avenue,
M4B 1 Y2
Toronto, Ontario
1-800-565-6699
www.schneider-electric.ca

Catalog No. 8840CT0101 January 2002 © 2002 Schneider Electric All Rights Reserved