

Molded case circuit breakers

Catalog

Compact™ CM 1250-2500 A

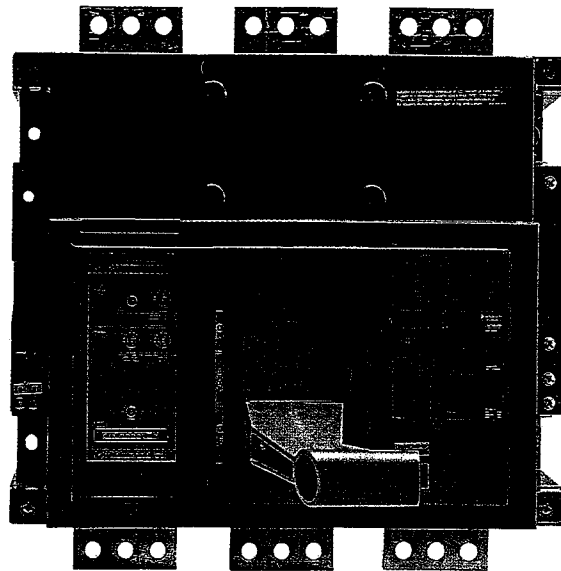

SQUARE D
GROUPE SCHNEIDER

Compact CM circuit breaker table of contents

	page
molded case circuit breaker	
introduction	
standard compliance	2
performance	2
other performances	2
ratings	2
interrupting capability	2
advantages	2
description	3
trip unit characteristics	
ST 206D	4
ST 306S - ST 316S	5
neutral sensor	6
portable test kit	6
test procedure	6
time current curves	
ST 206D (overcurrent protection)	7
ST 306S - ST 306ST - ST 316ST (overcurrent protection)	8
ST 306ST (ground fault protection)	9
ST 316ST (ground fault protection)	10
accessories	
terminals	11
location	11
shunt trip	12
undervoltage trip device	12
auxiliary and alarm switches	12
overcurrent trip switch	12
motor operator	13
OFF position locking	13
wiring diagrams	14
molded case switch	15
construction	15
ratings	15
accessories - dimensions - installation	15
dimensions	16
appendix	
UL 489 test procedures	20
application of 100% rated breakers	21
routine and maintenance guidelines	22
international standards	23

Compact CM circuit breaker introduction, advantages

standard compliance

CM breakers are built in accordance with Underwriters Laboratories standard UL 489. The circuit breaker and its accessories, except when noted, are listed under UL file E63335.

performance

CM breakers are designed to meet or exceed UL 489 requirements.

Standard tests: UL 489 standard section 7.1 gives test values for calibration, overload, temperature, endurance, interrupting ability, dielectric. On page 21 of this document, extracts of UL standards are given.

Additional tests: CM breakers meet UL 489 standard additional requirements:

- high available fault current
 - 100% rating
- as shown on page 21

other performances

The UL 489 standard assures that the circuit breaker has sufficient characteristics to be used in normal conditions.

However, CM circuit breakers exceed the standard requirements without additional cost:

in endurance : the heavy duty mechanism and contact design provides a mechanical endurance of 10,000 operations and an electrical endurance of 2,000 cycles

in accuracy : the solid state trip unit provides a more accurate protection than required by the standard, see time current curves page 7

interrupting ratings

CM type 3-pole	ampere ratings current sensors (A)	UL listed interrupting ratings RMS Symmetrical. Amps		
		240V	480V	600V
standard rated breaker				
CM 1250 HE	1250	125,000	85,000	50,000
CM 1600 HE	1600	125,000	85,000	50,000
CM 2000 HE	2000	125,000	85,000	50,000
CM 2500 HE	2500	125,000	85,000	50,000

100% rated breaker

CM 1250 HH	1250	125,000	85,000	50,000
CM 1600 HH	1600	125,000	85,000	50,000
CM 2000 HH	2000	125,000	85,000	50,000
CM 2500 HH	2500	125,000	85,000	50,000

ratings

Four continuous current ratings : 1250, 1600, 2000 and 2500A

Two types are listed :

- standard rated circuit breakers
- 100% rated circuit breakers

small dimensions

A unique and small insulating casing for all five ratings (1250 to 2500A) simplifies layout design and installation.

reverse feeding

maintenance free breaker design

reduces downtime and maintenance costs.

high endurances

The endurance of the design is four times greater than that required by the standards.

isolation function

The operating handle is representative of the position of the main contacts. The OFF position can be reached only when the main contacts are fully opened.

built-in control terminal blocks

Are provided with the accessories, consequently intermediate terminals are not required for the connection of control wiring.

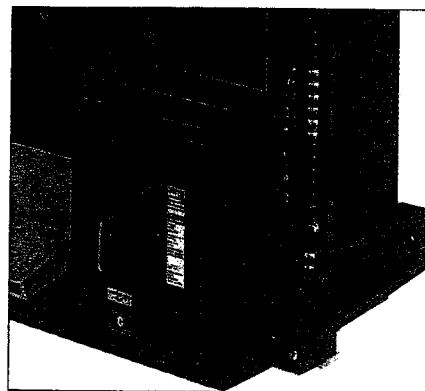

Compact CM circuit breaker description

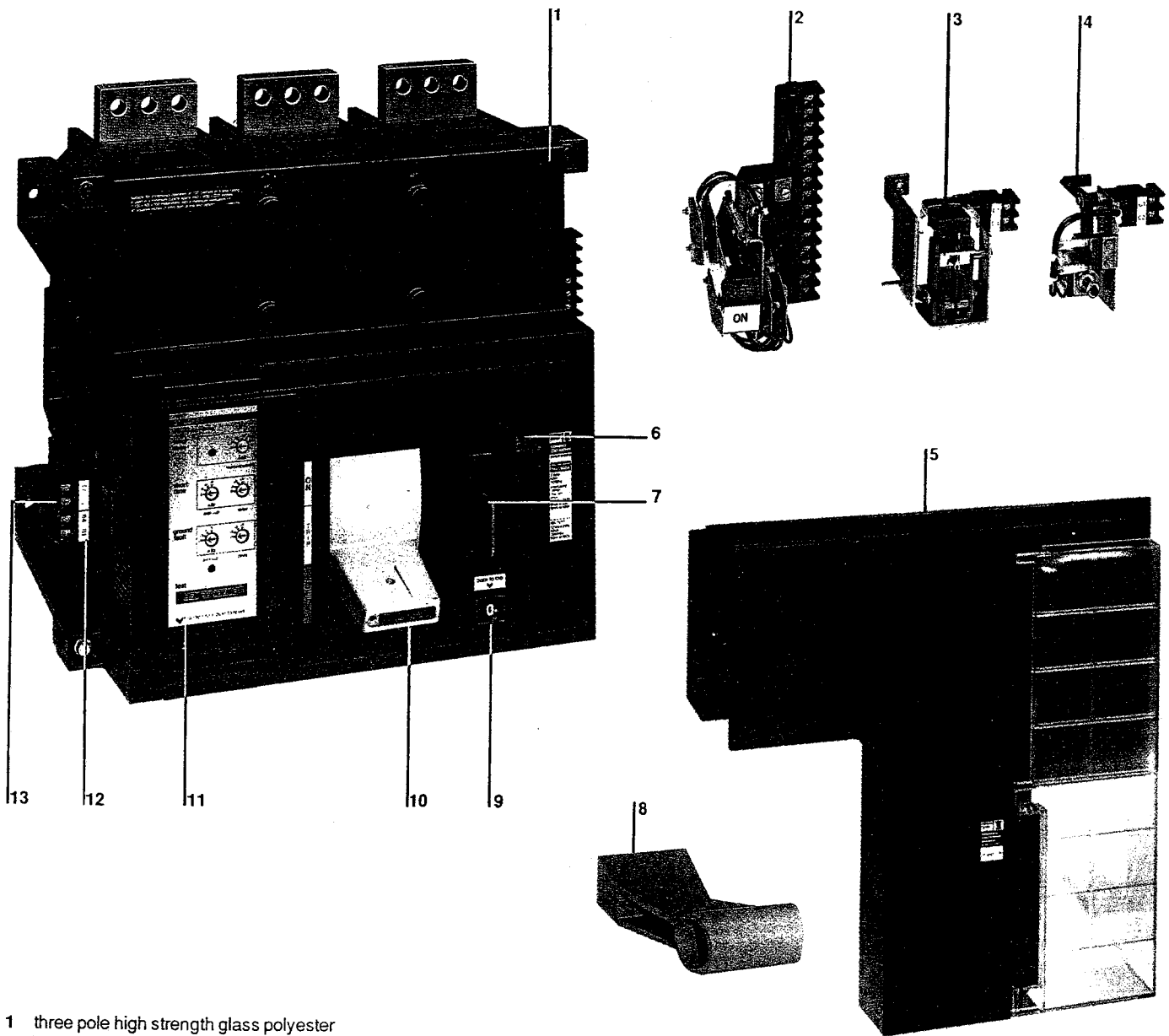

- 1 three pole high strength glass polyester casing
- 2 auxiliary and alarm switches
- 3 undervoltage trip device
- 4 shunt trip
- 5 motor operator
- 6 ON-OFF indicator directly operated by the mechanism (optional with auxiliary switches)
- 7 provisions for padlock, when contacts are actually opened
- 8 handle extension
- 9 push to trip button
- 10 handle with three positions :
ON-TRIPPED-OFF
- 11 solid state trip unit
- 12 overcurrent trip switch terminal block
- 13 neutral sensor terminal block

Compact CM circuit breaker trip units

ST206D
for general purpose

- 1 long time current setting
 - 2 instantaneous pickup
 - 3 mechanical fault trip indicator, pops out when the circuit breaker trips through the trip unit. It indicates any electrical fault, as does the overcurrent trip switch described on page 12. This indicator must be reset prior to resetting the circuit breaker
- note :** a transparent cover is provided. It is secured by two screws to prevent access to the settings by unauthorized personnel

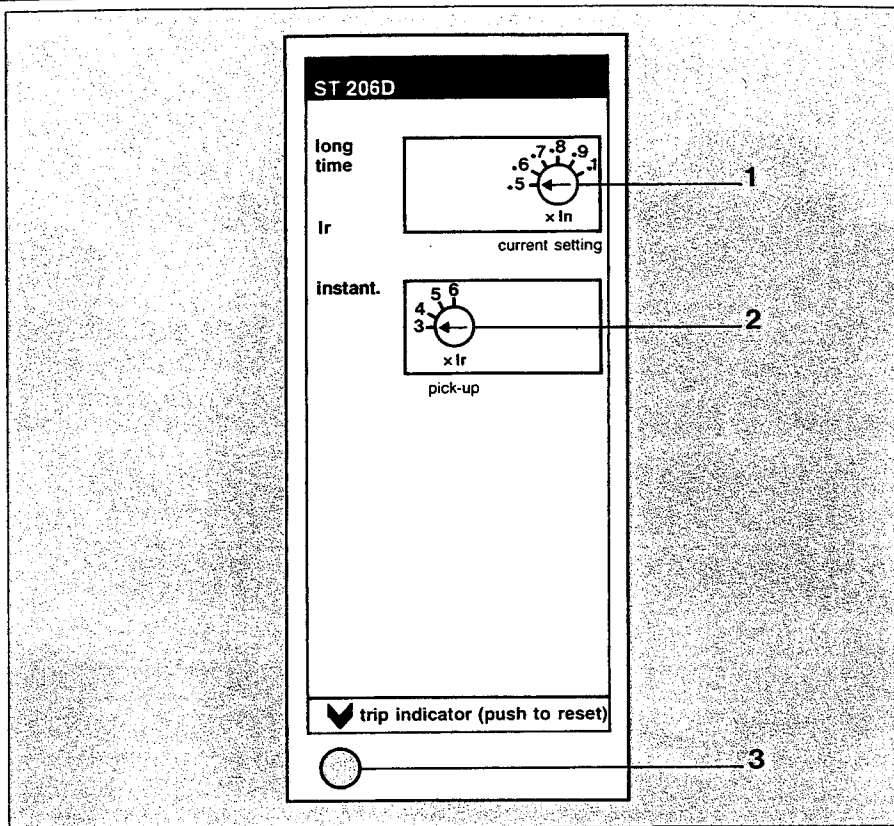
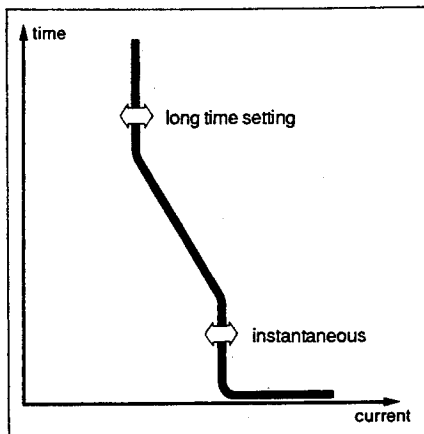

overcurrent protection

long time	current setting	0.5 to 1 x sensor rating
instantaneous	pick-up	3 to 6 x current setting

fault indicators

local	by mechanical pop-out type indicator
remote	by overcurrent trip switch - see page 12

Compact CM circuit breaker trip units

ST 306S - ST 316S

for selective application and ground fault protection

- 1 long time current setting
 - 2 short time pickup and delay
 - 3 ground fault pickup and delay
 - 4 test receptacle for use with portable test kit cat. no. 55391
 - 5 mechanical fault trip indicator, pops out when the circuit breaker trips through the trip unit. It indicates any electrical fault, as does the overcurrent trip switch described on page 12. This indicator must be reset prior to resetting the circuit breaker.
- note:** a transparent cover is provided. It is secured by two screws to prevent access to the settings by unauthorized personnel

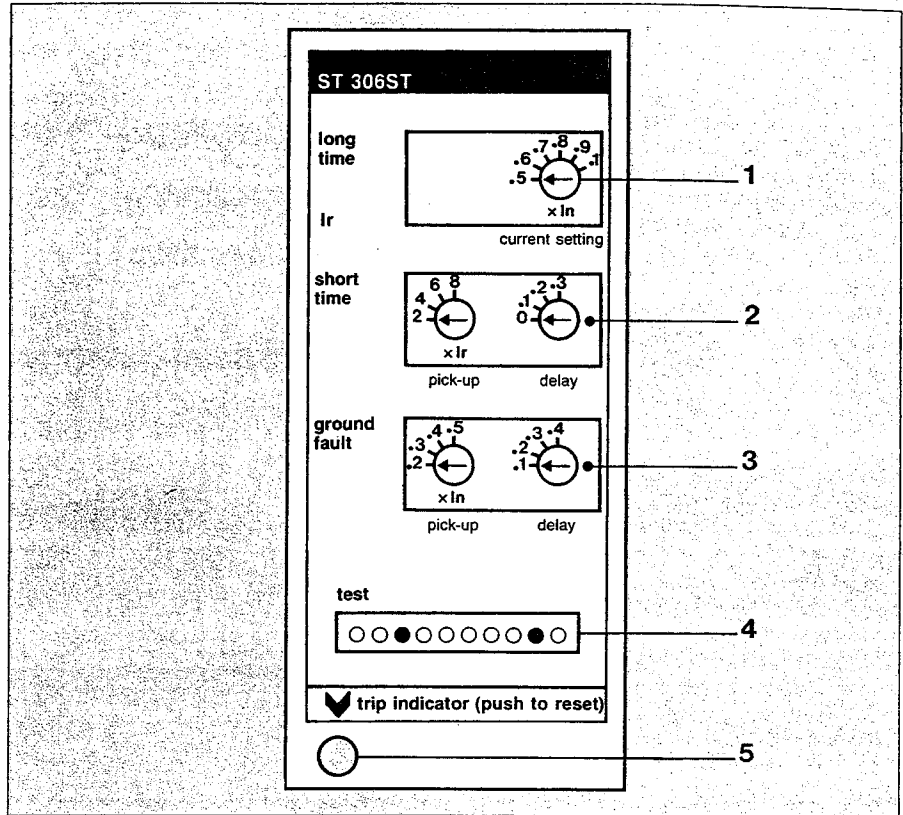
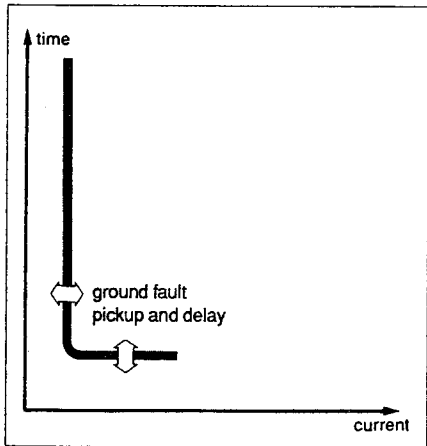
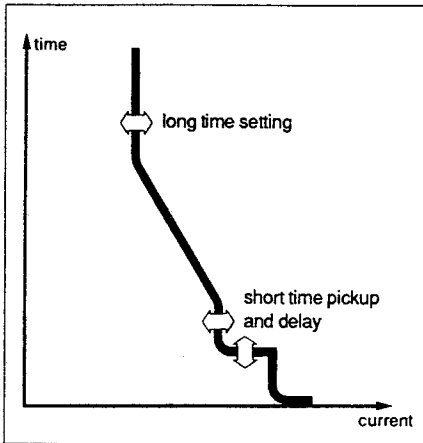

overcurrent protection

long time	current setting	0.5 to 1 x sensor rating
short time	pickup	2 to 8 x current setting
	delay	0 - 0.1 - 0.2 - 0.3 ①
instantaneous	pickup	override at 35,000A
test receptacle	for overcurrent and ground fault testing	

ground fault protection ②

(option T)	pickup	ST 306ST ③ : 0.2 to 0.5 x sensor rating ST 316ST ④ : 0.2 to 0.4 x sensor rating
	delay	0.1 - 0.2 - 0.3 - 0.4

fault indicators

local	by mechanical pop-out type indicator
remote	by overcurrent trip switch - see page 12

① The short time delay may be set at zero if instantaneous tripping is required

② The maximum ground fault pickup of ST 316ST meets 1996 National Electrical Code paragraph 230-95 (not to exceed 1200A).

③ Used on CM 1250 - CM 1600 and CM 2000

④ Used on CM 2500

Compact CM circuit breaker trip unit neutral sensor

neutral sensor
portable test kit

neutral sensor

Ground fault protection may be applied on 3Ø4W or 3Ø3W circuits. On 3Ø4W an external neutral sensor must be used.

This neutral current sensor shall have the same ampere rating as the breaker.

The following are current sensors for use with CM breakers equipped with ST 306ST or ST 316ST trip units.

rating	for	cat. no.
1250A	CM 1250	55760
1600A	CM 1600	55759
2000A	CM 2000	55758
2500A	CM 2500	55757

wiring

It shall be as indicated in opposite fig. and on the neutral sensor label. Observe control wiring (terminal S1-S2, T1-T2).

terminals

- terminals S1-S2 (neutral sensor) are of "quick-connect" type (1/4" male tab terminals are supplied with current sensors).
- terminals T1-T2 (circuit breaker) are pressure type terminal blocks. These terminals are intended for use with 18 to 14 AWG stranded copper wire.

portable test kit

All tests performed by the test kit are functional tests only designed to electrically test the operating integrity of the trip unit, the flux transfer shunt trip and the mechanical operation of the breaker. Tests are not designed as a check of the breaker calibration. Calibration tests can best be done at the factory.

Complete test operating instructions and required setting details are given on the side of the test kit. For convenience, the operating instructions are repeated below.

ST306S, ST306ST and ST316ST trip units are equipped with test points that can be used with the portable test kit.

This test kit allows independent tests on the three following protections :

- long time
- short time
- ground fault on ST 306ST and ST 316ST

The portable test kit should be supplied by a 120V 60Hz source.

Catalog number **55391**

location

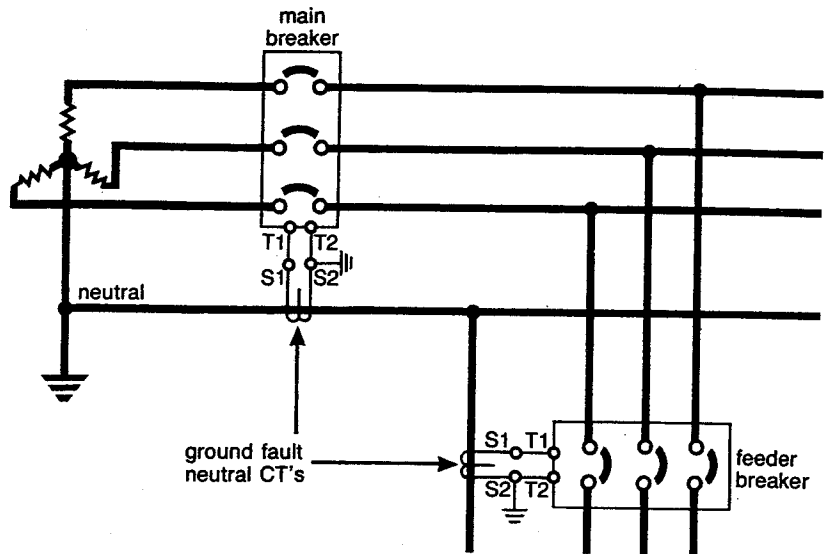

note : ground terminal T2 or S2

caution : in 3Ø4W systems, do not connect or do not short terminals T1 and T2

Compact CM circuit breaker time current curves

overcurrent protection ST 206D

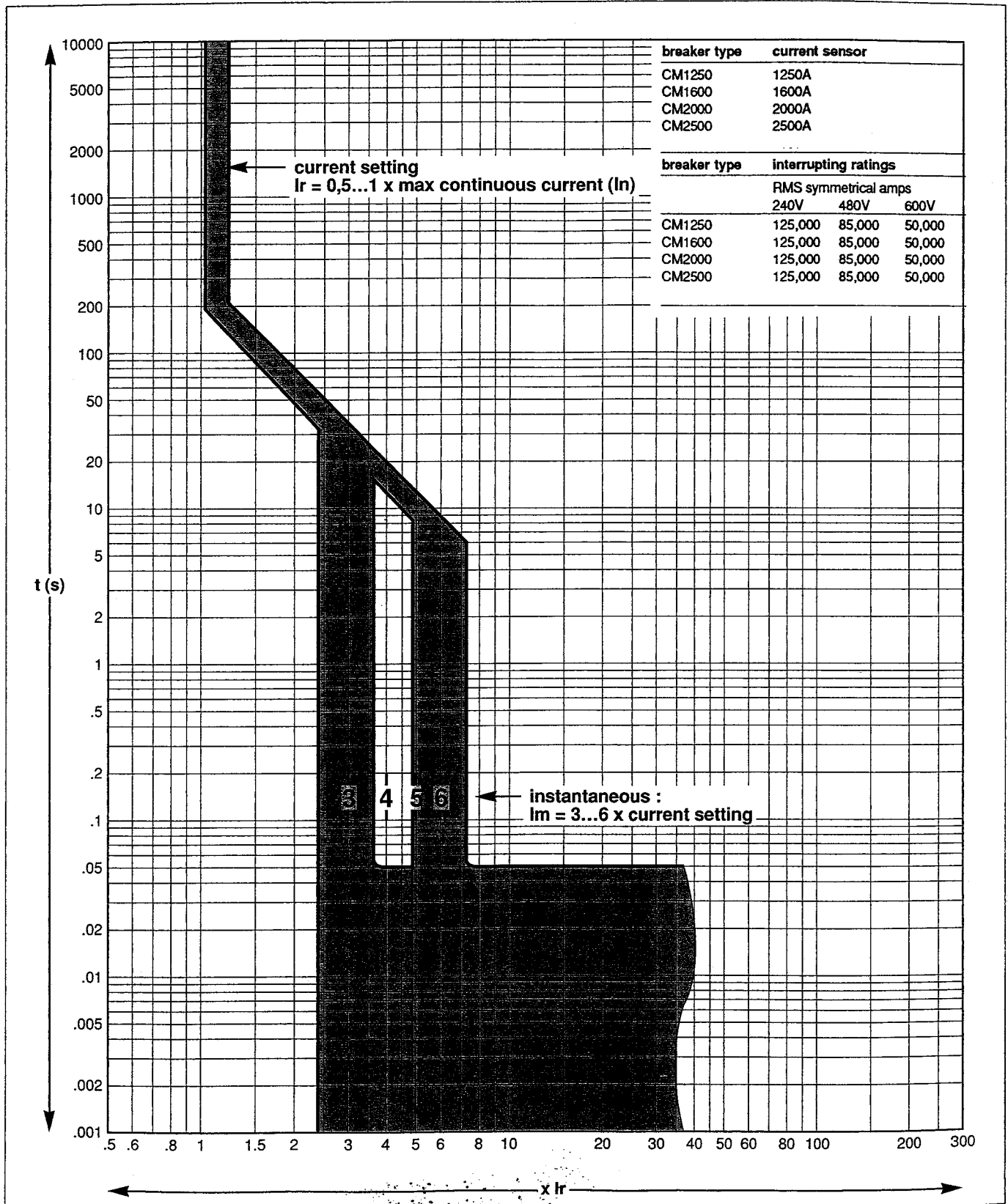

Compact CM circuit breaker time current curves

overcurrent protection ST 306S - ST306ST - ST 316ST

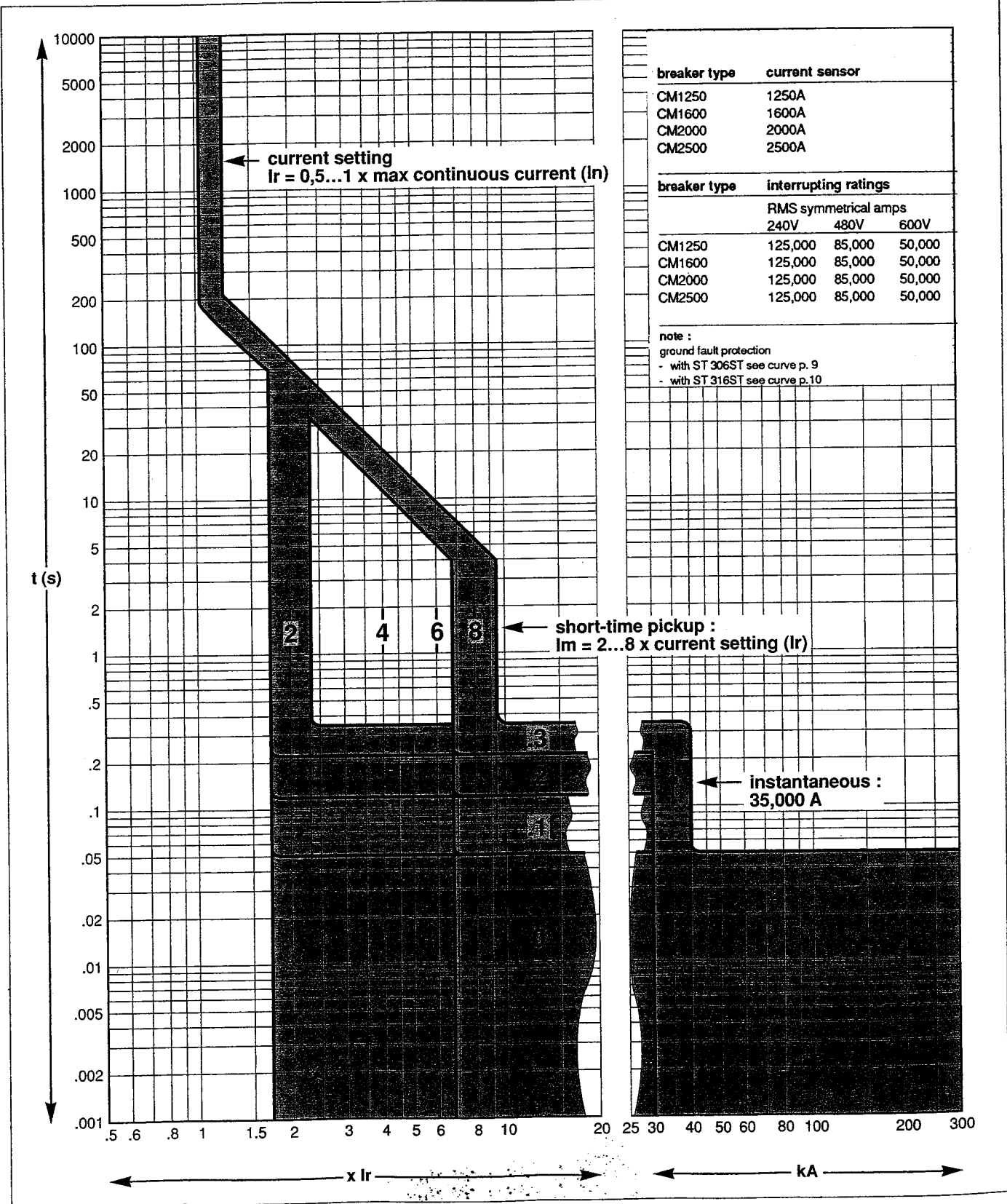

Compact CM circuit breaker time current curves

ground fault protection ST 306ST

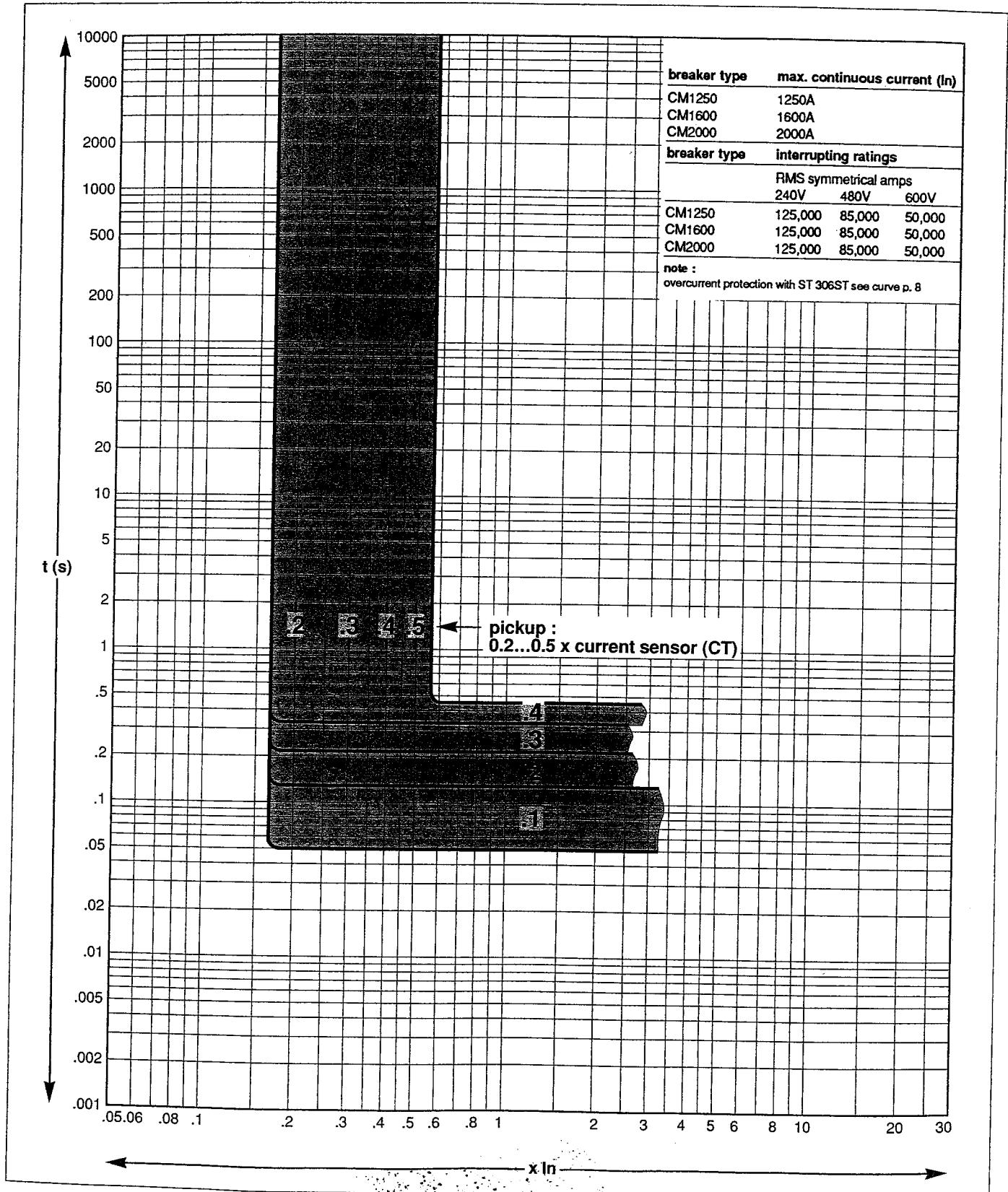

Compact CM circuit breaker time current curves

ground fault protection ST 316ST

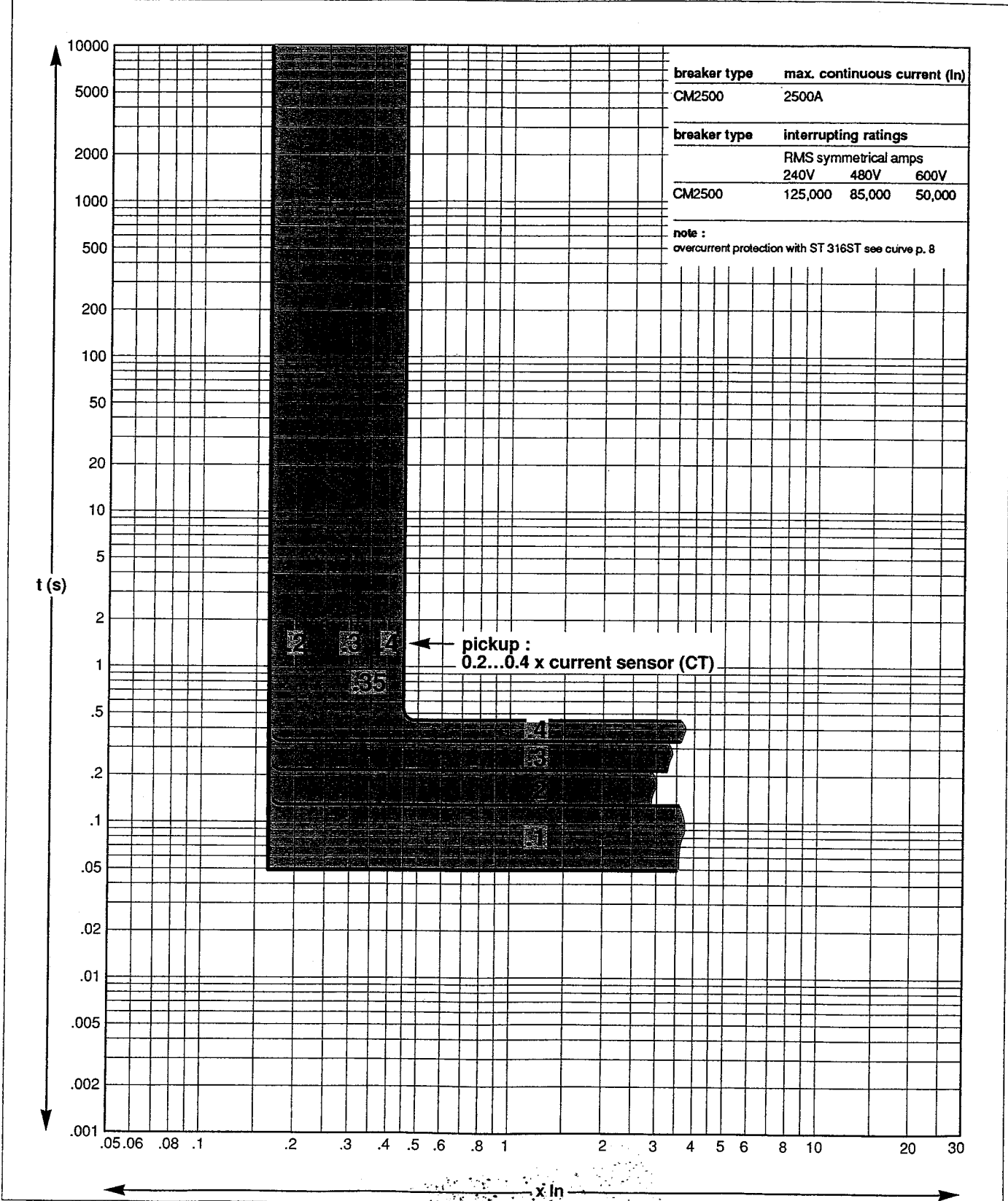

Compact CM circuit breaker accessories

terminals

Internal accessories are field installable and comply with requirements of Underwriters Laboratories Standard UL 489 and are listed for field installation per UL E103955.

terminals

All internal accessories are equipped with pressure type terminals located on the side of the breaker.

Each terminal may be connected by one or two copper wires 18 to 14AWG.

The terminals comply with Underwriters Laboratories Standard UL486A.

Tightening torque : 12 lb.in.

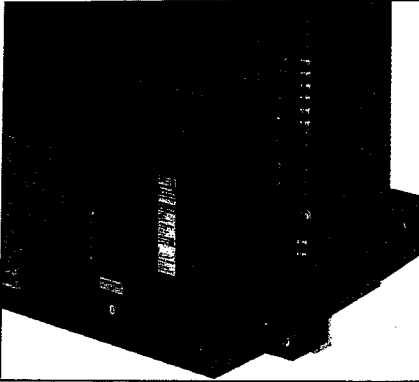

location

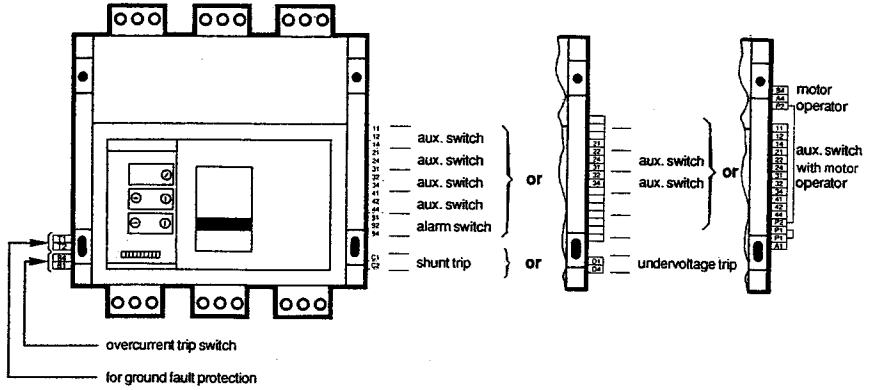

Compact CM circuit breaker accessories

shunt trip
undervoltage trip device
auxiliary and alarm switches
overcurrent trip switch

shunt trip

The shunt trip is intermittently rated with a series normally open contact. AC shunt trips can be operated at 55 percent of their rated voltage, making them suitable for use with ground fault protection devices.

minimum operating voltage :

AC : 55 % of rated voltage
DC : 75 % of rated voltage

opening time = 50 m sec.

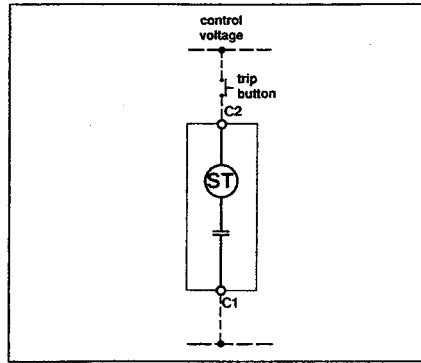

rated voltage (V)	inrush current (A)	cat. no.
60 Hz		
120	3.5	55740
240	1.9	55741
480	1	55742
600	0.65	55743
DC		
24	10	55744
48	4	55745
125	1.8	55746

undervoltage trip device

Undervoltage trip devices may be used as circuit interlocks. If an undervoltage condition exists, operation of the closing mechanism of the circuit breaker will not permit the main contacts to touch, even momentarily.

dropout : 35-70 % of rated voltage

pickup : 85 % of rated voltage

note : to prevent the breaker from tripping in the event of transient voltage drops, an external time delay may be added (fixed delay : min. 0.5 sec. - max. 1 sec., voltage : 120V AC, not UL listed)

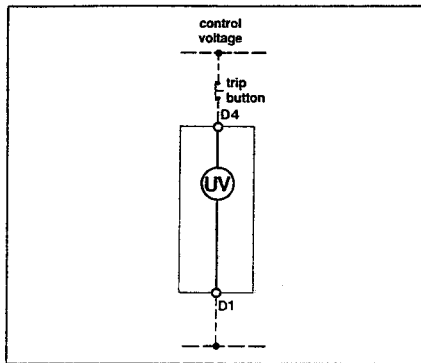

rated voltage (V)	seal-in current (A)	cat. no.
60 Hz		
120	0.5	55728
240	0.3	77729
480	0.15	55730
600	0.18	55731
DC		
24	0.14	55732
48	0.07	55733
125	0.02	55734

auxiliary and alarm switches

Auxiliary switches consist of SPDT switches and provide remote information of the breaker status.

Alarm switch provides alarm/lockout information. When the breaker is reset, the "a" contact (alarm) is open, and the "b" contact (lockout) is closed.

This SPDT switch is operated when the breaker is tripped by the trip unit, shunt trip or undervoltage trip device or "push-to-trip" button.

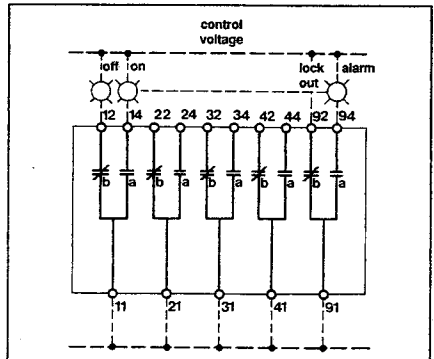
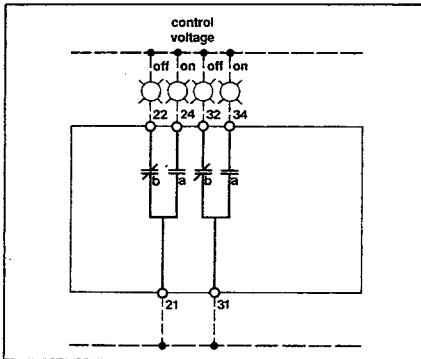

without motor operator

2 auxiliary switches **cat. no. 55755**

4 aux. + 1 alarm switch **cat. no. 55754**

for motor operator

4 auxiliary switches ① **cat. no. 55676**

① not UL listed

voltage (V)	2 auxiliary switches		4 auxiliary + 1 alarm switch	
	auxiliary	alarm	auxiliary	alarm
50/60 Hz	240 - 480	6	5	5
	600	3	3	3
DC	125	0.5	0.5	0.5
	250	0.25	0.25	0.25

overcurrent trip switch

Supplied as standard with the trip unit. Operates in the same way as the mechanical trip indicator.

The "a" contact closes when the breaker operates through the trip unit (overcurrent or ground fault). It does not operate if tripping is by shunt trip, undervoltage trip device or push-to-trip button.

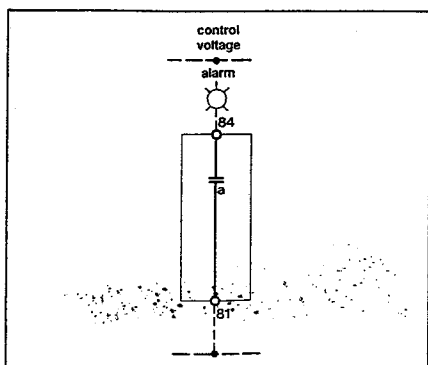

voltage (V)	current (A)	
50/60 Hz	240	2
DC	125	0.1

Compact CM circuit breaker accessories

motor operator OFF position locking

motor operator

The motor operator operates remotely the circuit breaker on orders from pushbuttons, switches or relays.

Remote opening is performed by shunt trip or undervoltage trip device. It ensures resetting and closing in the same time. ON and OFF positions are clearly indicated by a flag indication :

- white : ON
- green : OFF

Those two indicators are representative of the status of the main contacts : the OFF position can be indicated only when the main contacts are fully opened.

Not UL listed.

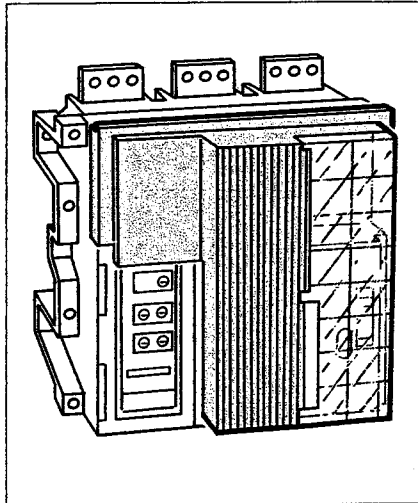

rated voltage (V)	cat.no.
60Hz	
120	55611
240	55613
277	55615
480	55617
DC	
24	55618
48	55620
125	55624

operating voltage : 80-110% of rated voltage

max. operation frequency : 2 per minute

consumption :

- closing : 350VA
- opening : refer to shunt trip or undervoltage trip device tables
- max. closing time : 1.5 sec.

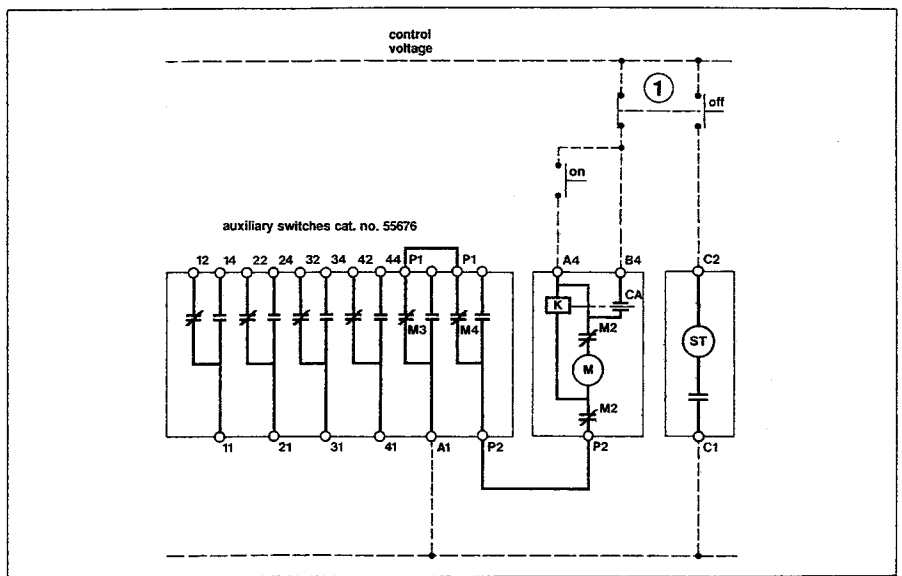

Ⓢ caution : control diagram shall be designed to interlock remote ON and OFF orders.

- CA-K auto-supply switch/relay
- M2 locking switches
- M3 auxiliary switches (automatic resetting)
- M4 alarm switch
- ST shunt trip

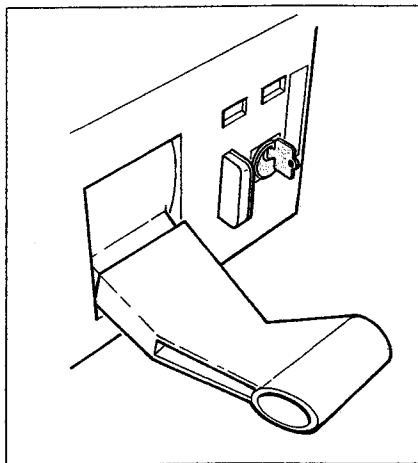
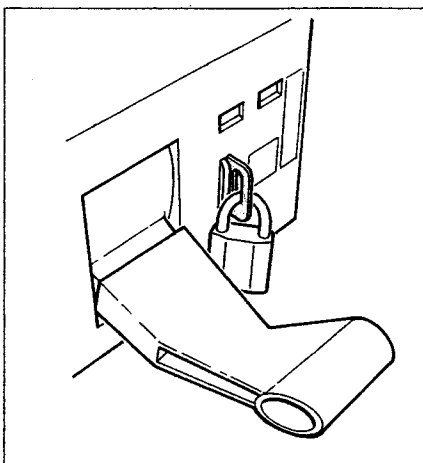

OFF position locking

The breaker can be locked in the OFF position by the means of 1 to and/or 3 padlocks (padlocks not provided) and 1 Kirk key lock (KIRK or CASTELL key lock is provided -Factory mounted).

note :

- The adaptator accomodates up to 3 padlocks.
- Padlock shackle diameter : 1/4 to 5/16
- keylock is of the captive key type, free when locked.

padlocking device	cat no. 55653
prov. for KIRK key lock	cat no. 55768
KIRK key lock	cat no. 35635
prov. for CASTELL key lock [®]	cat no. 55769

Ⓢ includes padlocking device

Compact CM circuit breaker wiring diagrams

auxiliary switches
remote operation

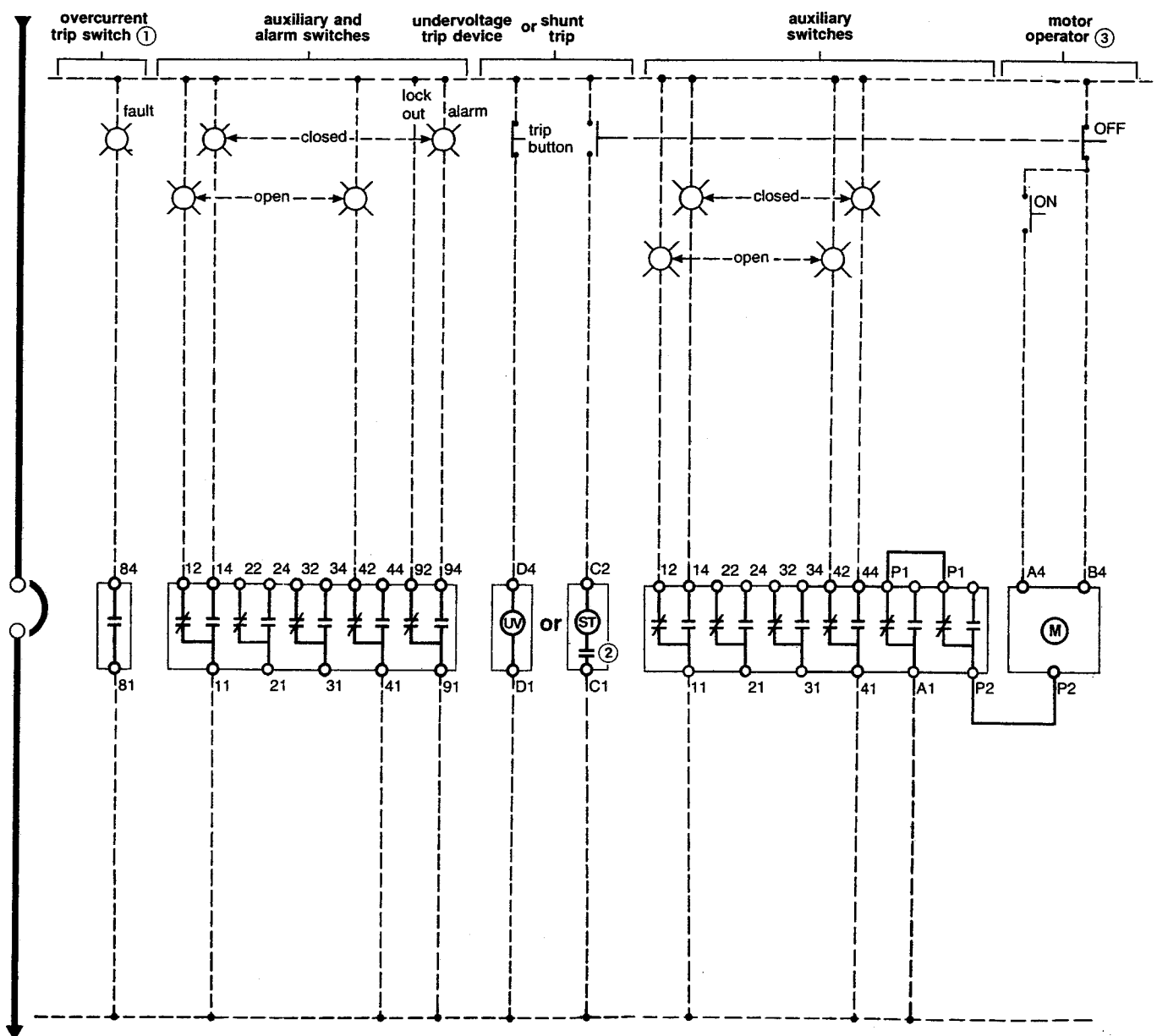

① not available on molded case switch
 ② self cut-off switch
 ③ see page 13 for internal wiring diagrams
note : contacts are shown with the breaker in the open and reset position

Compact CM molded case switch

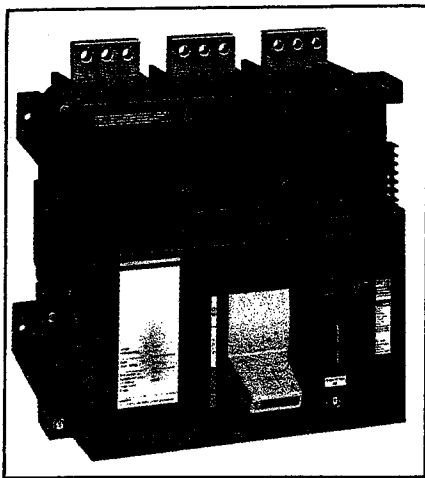

construction

CM molded case switch is designed identically to CM molded case circuit breaker, except that it is not equipped with a trip unit. High instantaneous trip at 35,000 Amps. UL listed under file E103740.

Caution :

molded case switches does not provide overcurrent protection. Molded case switch can be protected by a CM circuit breaker.

ratings

m.c.s. 600V	ampere rating (A)		short circuit withstand max. sym. Amps	when protected by
CM 1600HA	1600	at 240V	125,000	CM1600
		at 480V	85,000	CM1600
		at 600V	50,000	CM1600
CM 2000HA	2000	at 240V	125,000	CM2000
		at 480V	85,000	CM2000
		at 600V	50,000	CM2000
CM 2500HA	2500	at 240V	125,000	CM2500
		at 480V	85,000	CM2500
		at 600V	50,000	CM2500

accessories-dimensions- installation

Molded case switch accessories, dimensions, installation and connection are identical to those of the corresponding circuit breaker (except for overcurrent trip switch).

	page
accessories	11
dimensions	16

Compact CM circuit breaker dimensions

CM 1250 - CM 1600

inch / mm

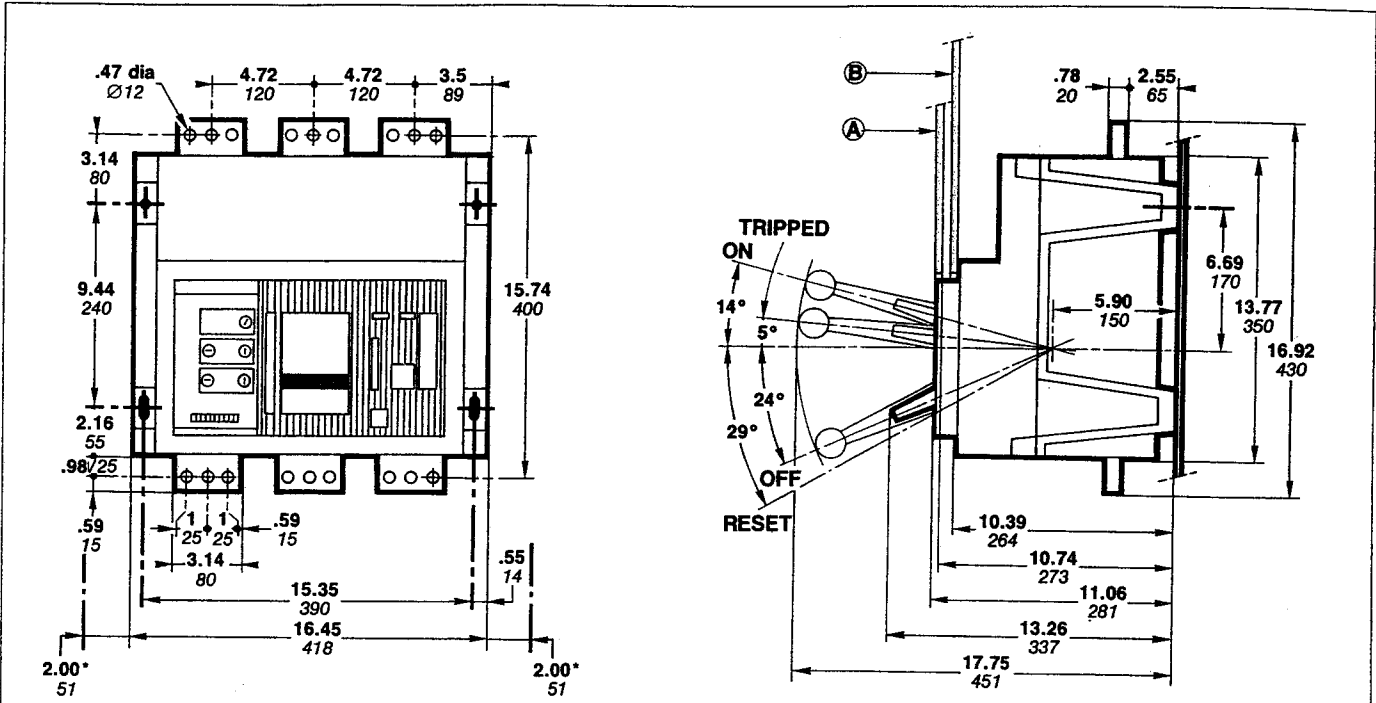

(*): approximate control wire-bending space

note: CM 1250 and CM 1600 type HH are suitable for continuous operation at 100 percent of frame rating if used a minimum cubicle space of H43 x W30 x D20 inches (1100 x 800 x 500 mm) with a minimum ventilation of 90 square inches (6 dm²) both at top and bottom.

Drilling for attachment to panel

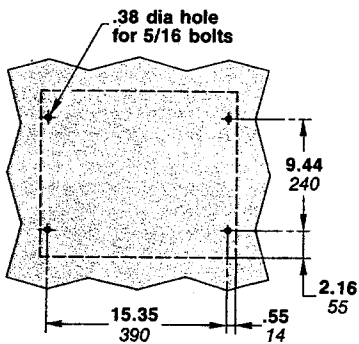

Door cutout

Ⓐ trip unit behind door

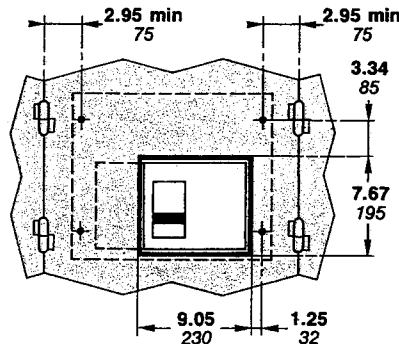

Ⓑ trip unit through door

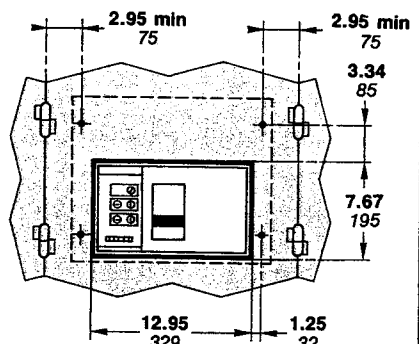

approximate shipping weights : 90lbs - 41kg

Compact CM circuit breaker dimensions

CM 2000

inch / mm

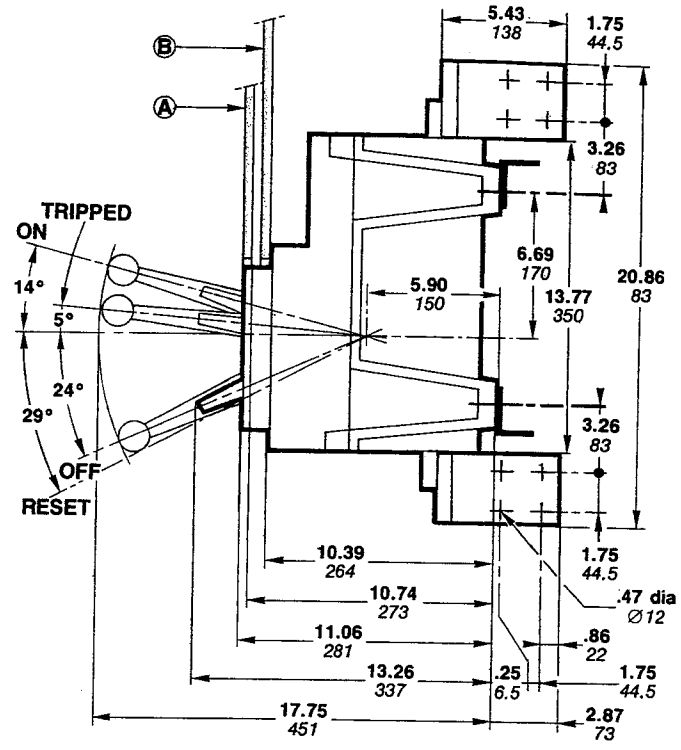
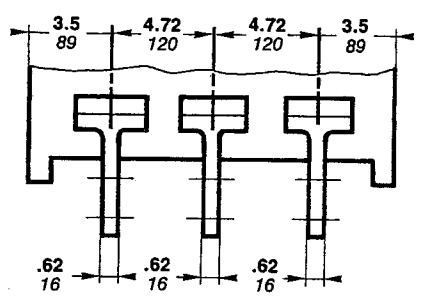
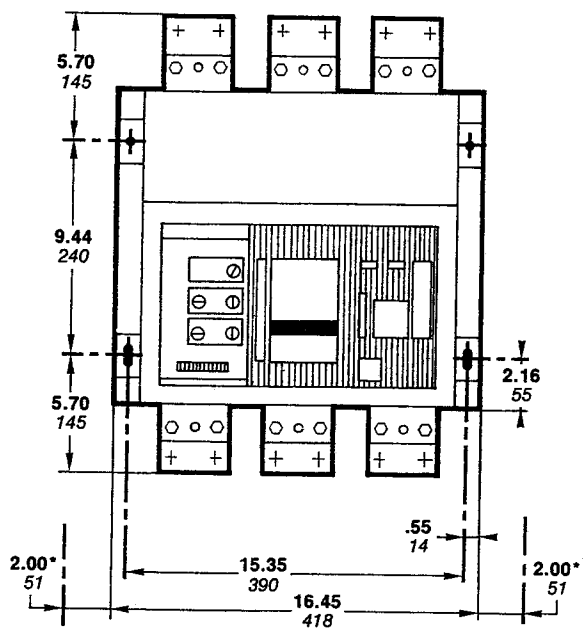

note: CM 2000 type HH are suitable for continuous operation at 100 percent of frame rating if used a minimum cubicle space of H43 x W30 x D20 inches (1100 x 800 x 500 mm) with a minimum ventilation of 90 square inches (6 dm²) both at top and bottom.

(*): approximate control wire-bending space

Drilling for attachment on rail (only)

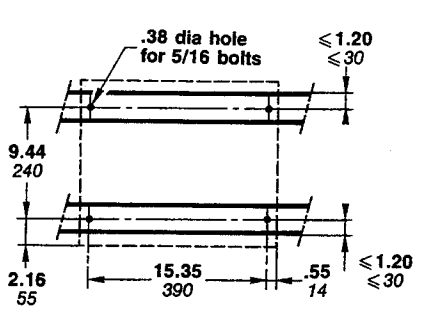

Door cutout

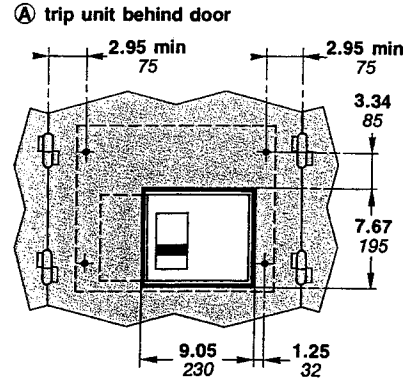

(B) trip unit through door

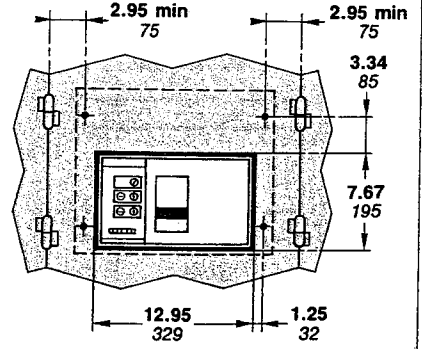

approximate shipping weights : 118lbs - 54kg

Compact CM circuit breaker dimensions

CM 2500

inch / mm

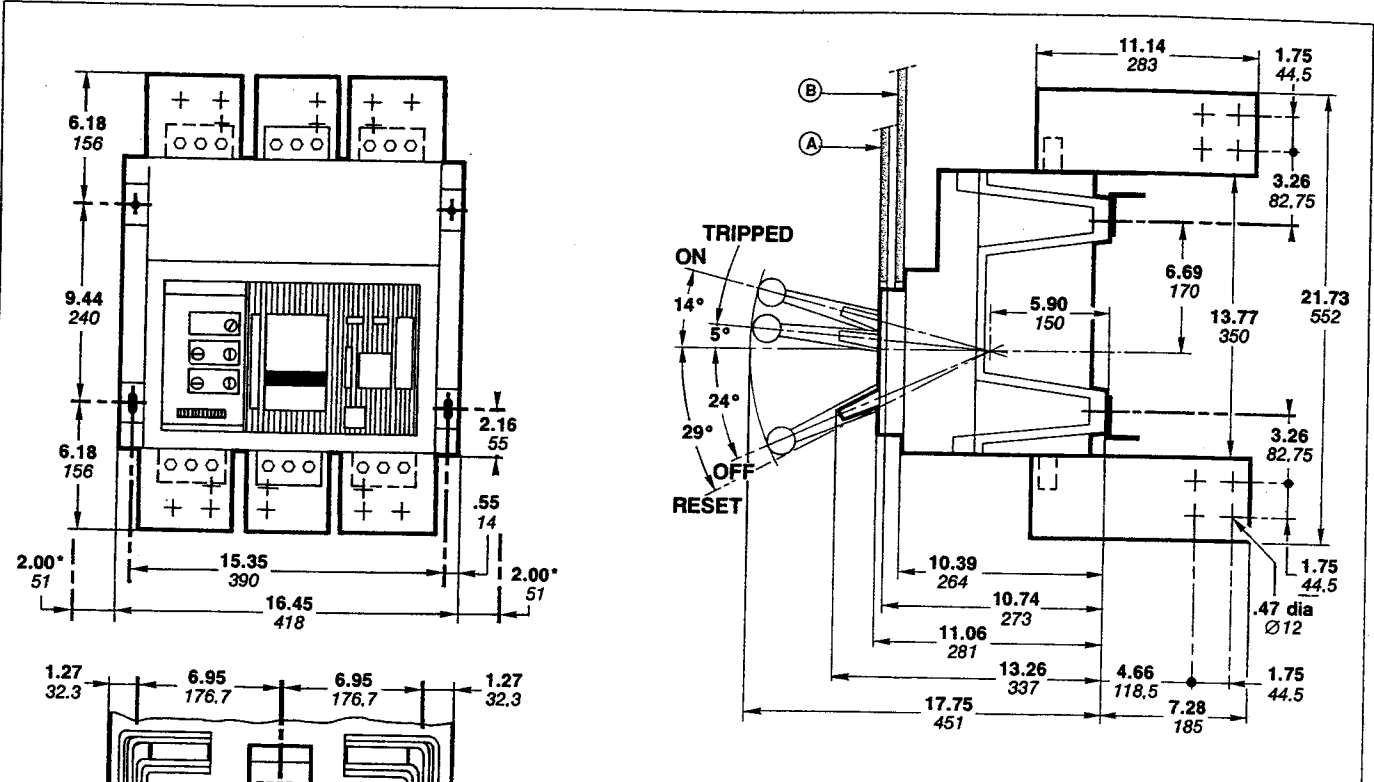

note: CM 2500 and CM 3000 type HH are suitable for continuous operation at 100 percent of frame rating if used a minimum cubicle space of H43 x W30 x D20 inches (1100 x 800 x 500 mm) with a minimum ventilation of 90 square inches (6 dm²) both at top and bottom.

(*): approximate control wire-bending space

Drilling for attachment on rail (only)

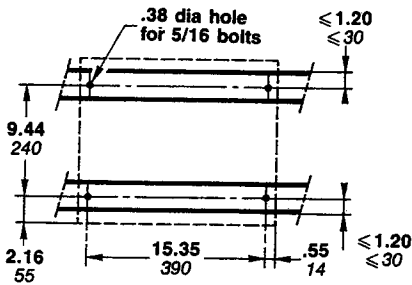

Door cutout

Ⓐ trip unit behind door

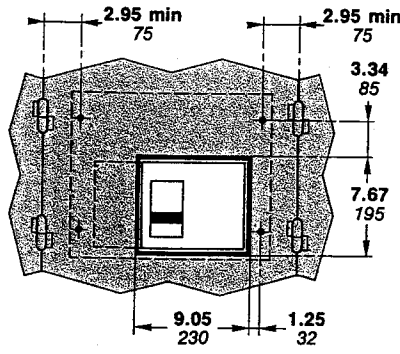

Ⓑ trip unit through door

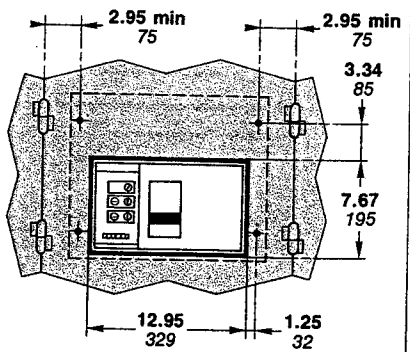

approximate shipping weights : 195lbs - 89kg

Compact CM circuit breaker dimensions

inch / mm

motor operator
neutral sensor

motor operator

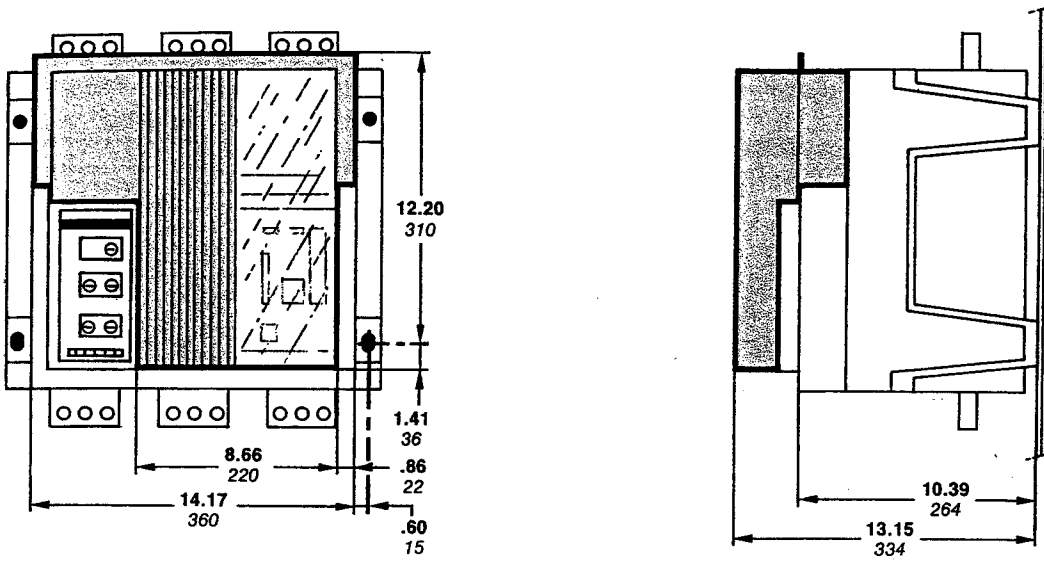

neutral sensor

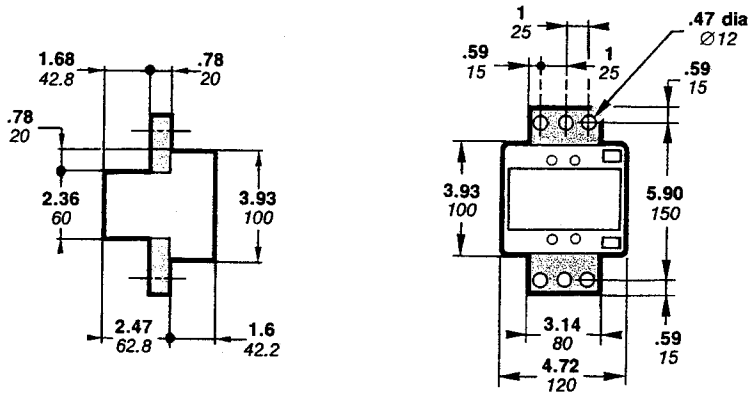

standard tests

For solid state trip breaker, and uncompensated thermal breaker rated 40°C, the test sequences are :

test	sequence		
	X	Y	Z
200% calibration at 25°C (77°F)	<input type="checkbox"/>	<input type="checkbox"/>	<input type="checkbox"/>
135% calibration at 25°C (77°F)	<input type="checkbox"/>	<input type="checkbox"/>	
calibration of adjust instant trip overload	<input type="checkbox"/>	<input type="checkbox"/>	
100% calibration at 40°C (104°F)	①		
temperature and 100% calibration at 25°C (77°F) endurance	<input type="checkbox"/>		
200% calibration at 25°C (77°F) repeated		<input type="checkbox"/>	
135% calibration at 25°C (77°F) repeated		<input type="checkbox"/>	
interrupting ability (Y sequence)		<input type="checkbox"/>	
interrupting ability (Z sequence)			<input type="checkbox"/>
200% trip out at 25°C (77°F)		<input type="checkbox"/>	<input type="checkbox"/>
dielectric voltage withstand	<input type="checkbox"/>	<input type="checkbox"/>	<input type="checkbox"/>

① Applies only for thermal breakers rated 40°C.

standard specifications

200% calibration at 25°C

The breaker must trip within time limits which depend on the rating from 3 minutes for a 30A rated breaker, up to 30 minutes over 2000A.

135% calibration at 25°C

The breaker must trip within two hours (for breakers rated more than 50 A).

Calibration of adjustable instantaneous trip

The breaker must trip within the range of 80-130% of the maximum marked tripping current and 75-125% of the minimum marked tripping current.

Overload

- up to 1600A : fifty operations at 600% of rated current
- 2000 and 2500A : twenty-five operations at 600 % of rated current
- 3000 to 6000A : three operations at 600% followed by twenty-five operations at 200 % of rated current.

The power factor shall be from 0.45 to 0.50 lagging.

Temperature

When connected with specified cables or bus bars (see below) and with its rated current, the temperature rises on the breaker and at its terminals does not exceed specified limits.

Examples of specified wires and bus
■ "75°C" copper wire

rating	number	size
100A	1	1AWG (60°C)
	or 1	3 AWG
250A	1	250 MCM
400A	2	3/0 AWG
600A	2	350 MCM
800A	3	300 MCM
1000A	3	400 MCM
1200A	4	350 MCM

■ copper bus bar

rating	number	size
1600A	2	1/4 x 3
2000A	2	1/4 x 4
2500A	2	1/4 x 5
	or 4	1/4 x 2.5

(1200A or less : 1000A / in²)

Endurance

The breaker must complete an endurance test :

- operations at rated current and rated voltage
 - followed by no load operation .
- The power factor shall be 0.75 to 0.80 lagging.

Examples:

frame size	number of cycles of operations		
	with current	without current	total
100A	6,000	4,000	10,000
225A	4,000	4,000	8,000
600A	1,000	5,000	6,000
800A	500	3,000	3,500
1200A	500	2,000	2,500
1600A	500	2,000	2,500
2000A	500	2,000	2,500
2500A	500	2,000	2,500

Interrupting ability (Y sequence)

After endurance tests and calibrations repeated, the breaker completes an opening followed by a close-open operation (O-t-CO), with specified current.

Examples for three pole breakers:

frame rating	RMS Sym. Amps (3-pole O-t-CO)
100A ①	3,000
225A	3,000
400A	5,000
600A	6,000
800A	10,000
1200A	14,000
1600A	20,000
2000A	25,000
2500A	35,000

① Above 250V.

Interrupting ability (Z sequence)

A 3-pole breaker rated 240, 480 or 600V have to complete an opening operation and a close-open operation (O-t-CO) on each pole, at rated voltage, followed by an opening operation (O) using all the three poles for the frame sizes up to 1200A, an additional close-open operation on the three poles is required).

Examples for 3-pole breaker :

frame rating	RM Sym. Amps		
	each pole	common	
	O-t-CO	O	O-t-CO
100 to 800A	8,660	10,000	
1000 to 1200A	12,120	14,000	
1600A	14,000	20,000	
2000A	14,000	25,000	
2500A	25,000	35,000	

Dielectric

After tests, the breaker must withstand for one minute a voltage of 1000V plus twice the rated voltage between :

- line and load terminals
- terminals of opposite polarity
- live parts and the overall enclosure

Optional tests :

■ high available fault current

Breakers having passed all the standard tests may have the UL label applied at higher values than the standard.

Test sequence is as follow :

- 200 % calibration
- interrupting capacity : an opening operation followed by a close open operation (O-t-CO) on all poles are performed on the circuit breaker.

The power factor over 20000A shall be 0.15 to 0.2 lagging.

- trip out at 250%
- dielectric at twice the rated test voltage.

■ 100% rated

Breakers having passed all the standard tests may have the UL label applied to use the circuit breaker in an enclosure, when carrying 100% of its maximum rating. The circuit breaker is submitted to additional temperature tests performed as in Standard tests, except that the breaker is installed in an enclosure. The dimensions and possible ventilations shall be recorded and shall be marked on the breaker.

tests on accessories

Shunt trip and undervoltage trip

These devices are submitted to temperature, overvoltage, operation, endurance and dielectric tests.

■ Overvoltage test

It checks that the device is capable of withstanding 110% of its rated voltage continuously without injury (this test does not apply to a shunt trip with an "a" contact connected in series).

■ Operation

The shunt trip must operate at 75% of its rated voltage (except that shunt trip devices for use with ground fault protection shall operate at 55%).

The undervoltage trip must trip the breaker when the voltage is between 35 and 70% of its rated voltage and shall seal (i.e.: the breaker cannot be turned on ON position) when the voltage is at 85% or more of its rated voltage.

■ Endurance

The device must be capable of performing successfully for 10% of the number of "with current" operations of the breaker.

Auxiliary and alarm switches

Auxiliary and alarm switches must be submitted to temperature, overload, endurance and dielectric tests.

■ Overload test

The test consists of fifty operations making and breaking 150% of rated current at rated voltage, with a 75-80% power factor in AC and non inductive load in DC.

■ Endurance

The switch must make and break its rated current at rated voltage, with a 75-80% power factor in AC, and non inductive load in AC for 100% of the number of operations "with current" for auxiliary switches, and 10% of this number for alarm switches.

recommended inspection intervals

Merlin Gerin circuit breakers are designed to be maintenance-free. However, all equipment with moving parts requires periodic inspection to ensure optimum performance and reliability. We recommend that the circuit breakers be routinely inspected six months after installation, followed by annual inspection. Intervals can vary depending on your particular experience.

inspection of terminals

Connections to circuit breaker terminals could be inspected. If there is discoloration due to overheating, the joint should be disassembled and the surface cleaned before reinstallation. It is essential that electrical connections be made carefully in order to prevent overheating.

- Check for terminal tightness.

cleaning

Remove the dust and dirt that have accumulated on the circuit breaker surface and terminals.

mechanical checks

Even over long periods circuit breakers are not often required to operate on overload or short-circuit conditions. Therefore it is essential to operate the breaker periodically.

To trip the breaker, push the push-to-trip button.

insulation resistance tests

When breakers are subjected to severe operating conditions, insulation resistance test should be performed as indicated in NEMA standard publication no AB2-1980. An insulation resistance test is used to determine the quality of the insulation between phases and phase to ground. The resistance test is made with a DC voltage higher than the rated voltage, to determine the actual resistance of the insulation. The most common method employs a "megger" type instrument. A 1000V instrument will provide a more reliable test because it is capable of detecting tracking on insulated surfaces. Resistance values below 1 megohm are unsafe and should be investigated. An insulation test should be made :

- between line and load terminals of individual poles with the circuit breaker contacts open.
- between adjacent poles and from poles to the metallic supporting structure with the circuit breaker contacts closed. The latter test may be done with the circuit breaker in place after the line and load conductors have been removed, or with the circuit breaker bolted to a metallic base which simulates the in-service mounting.

electrical tests

These tests require equipment for conducting pole resistance, overcurrent and instantaneous tripping, in accordance with NEMA standard publication AB4. They are not within the scope of normal field operation.

DANGER

HAZARD OF ELECTRIC SHOCK, BURN OR EXPLOSION.

- This equipment must be installed and serviced only by qualified electrical personnel.
- Turn off all power supplying this equipment before working on or inside equipment.
- Always use a properly rated voltage sensing device to confirm power is off.
- Replace all devices, doors, and covers before turning on power to this equipment.

Failure to follow these instructions will result in death or serious injury.

molded case circuit breaker

In addition to UL 489 standard, CM breakers comply with IEC 947-2 standard as per table below :

CM type 3-pole	ampere rating (A)	interrupting ratings				
		U/L 489 listed			IEC 947-2	
		RMS Sym. Amps				
		240V	480V	600V	380/415V	660V
standard rated breaker						
CM 1250HE	1250	125,000	85,000	50,000	85,000	50,000
CM 1600HE	1600	125,000	85,000	50,000	85,000	50,000
CM 2000HE	2000	125,000	85,000	50,000	85,000	50,000
CM 2500HE	2500	125,000	85,000	50,000	85,000	50,000
100% rated breaker						
CM 1250HH	1250	125,000	85,000	50,000	85,000	50,000
CM 1600HH	1600	125,000	85,000	50,000	85,000	50,000
CM 2000HH	2000	125,000	85,000	50,000	85,000	50,000
CM 2500HH	2500	125,000	85,000	50,000	85,000	50,000

shunt trip

rated voltage (V)			
UL 489 listed		IEC 947-2	
60Hz	120	50/60 Hz	110-127
	240		220-240
	480		380-415
DC	24	DC	24
	48		48
	125		125

undervoltage trip device

rated voltage (V)			
UL 489 listed		IEC 947-2	
DC	24	DC	24
	48		48
	125		125

auxiliary switches, alarm switch, overcurrent trip switch

IEC 947-2 characteristics are the same as those indicated in page 12.

circuit breakers for compliance with other world standards

Where compliance with IEC standards is required, Merlin Gerin offers a versatile range (not UL listed) of CM circuit breakers to meet your specific needs. Units include three or four poles, voltages up to 660V ratings from 1250A to 3200A, interrupting capabilities of 85,000A at 415V, and 50,000A at 660V. An extensive range of accessories complements the product line. For further information, please contact your Merlin Gerin representative.

