

# LH4 Modular Soft Start

File 8637

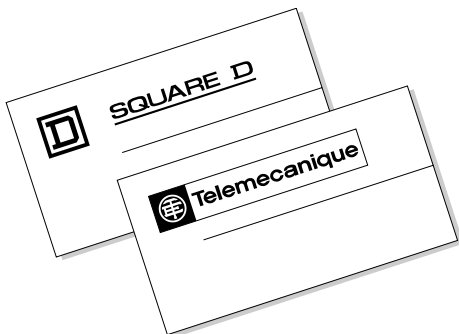

## CATALOG CONTENTS

Description .....	Page
General Information .....	3
Characteristics .....	4-5
References .....	6
Dimensions and Mounting .....	7-8
Recommended Wiring Schemes .....	9-11
List of Recommended Components .....	12
Control Connections .....	13
Application Notes .....	14



**SQUARE D**  
GROUPE SCHNEIDER



## INTRODUCTION

Asynchronous motors are the most common motors because they are reliable, standardized, and relatively inexpensive. However, in some cases when started across the line, an asynchronous motor may develop excessive torque or draw excessive current which can damage the driven machinery, material in process, or may cause the line voltage to drop.

LH4N modular soft starts provide gradual starting of asynchronous motors by using solid state power devices to control the voltage applied during acceleration. By reducing the voltage supplied to the motor during acceleration, the amount of starting torque is reduced which helps reduce mechanical shocks and may prevent premature bearing wear, shaft and belt breakage, damage to material in process, and costly downtime.

The LH4N soft start is available in two configurations:

- The LH4-N1 can be used with single or three phase motors where a simple voltage ramp is required to reduce mechanical wear and increase process performance. The compact package (45 mm x 110 mm) is a snap to install and no control wiring is required. Typical applications include small conveyors, sorting machinery, overhead doors or small belt driven machinery.
- The LH4-N2 is a higher performance version for use with three phase motors. In addition to reducing the starting torque, inrush current is reduced and a soft stop can also be provided. Typical applications include conveyors, pumps, compressors and fans.

## OPERATION

The LH4N modular soft start must be used with galvanic isolation of the soft start from the motor when the motor is not in use. The LH4N is designed for use downstream of a motor starter circuit which includes approved motor overload and short circuit protection.

The initial torque and ramp time can be adjusted via potentiometers which are easily accessible on the front panel of the device. The LH4N modular soft start will ramp the voltage from the initial torque requirement to rated voltage over the acceleration time. The voltage ramp is initiated when voltage is present on the line side of the device eliminating the need for additional control circuitry in many cases. The motor is supplied with reduced voltage in one phase when using the LH4-N1 and two phases when using the LH4-N2 soft start modules.

Once the ramp is complete, the SCRs are bypassed internally which allows for cool, efficient operation. A green LED is illuminated to indicate that power is present, while a yellow LED illuminates after the ramp is complete—indicating that the bypass is active. The internal bypass drops out when a stop command is given, with or without controlled deceleration.

On the LH4-N2 soft start, a third potentiometer can be used to adjust the voltage ramp down time following a stop command. A seal in contact is provided to keep the upstream contactor energized during the deceleration ramp and to indicate that the LH4N is functioning properly.

For LH4-N1 and N2 devices rated 25 amps and below, the control power is provided internally and the device may only be used at the voltage for which it is rated. For LH4-N2 devices rated 32 amps and above, 115 Vac external control power is required but any product may be used at any voltage between 200 and 600 Vac. When external control power is required, it must be applied at the same time a run command is given as the voltage ramp begins when voltage is present on the line side of the device.

On the LH4-N2 soft starts rated 32 amps and above, indication of the end of ramp can be provided by adding an auxiliary contact to the bypass contactor. Auxiliary relay LA8-DN●● must be ordered separately.

## PRODUCT RANGE

The LH4N product range is available in the following ratings:

	LH4-N1	LH4-N2	
	Soft start only	Soft start / soft stop	
<b>Amp ratings</b>	6 - 12 - 25	6 - 12 - 25	32 - 44 - 72 - 85
<b>Motor ratings</b>	Single or three phase 200 to 500 Vac	Three phase only 200 to 500 Vac	Three phase only 200 to 600 Vac
<b>Control power</b>	Internal	Internal	115 Vac external
<b>Ramp time</b>	0.5 to 5 seconds	0.5 to 5 seconds	0.5 to 25 seconds



# LH4 Modular Soft Start Characteristics

## Environment

<b>Rated Insulation voltage (Ui)</b>	Conforming to IEC 947	V	690
<b>Rated impulse withstand voltage (Uimp)</b>	Conforming to IEC 947	kV	6 and 8 for LH4-N2●●LY7 products
<b>Conforming to standards</b>			IEC / EN 60 947-4-2
<b>Product certifications</b>			ECC (low voltage and EMC) - UL - CSA
<b>Degree of protection</b>			IP 20
<b>Maximum relative humidity</b>			93% without condensation or dripping water
<b>Maximum ambient pollution</b>			Degree 3 conforming to IEC 664-1 and UL 508 / 840
<b>Ambient air temperature in the vicinity of the device</b>	For operation	°C	-10...+40 with derating of 1.2% per °C above 40°C and up to 60°C for LH4N rated 25 A and below. -10...+55 for LH4-N2 from 32 A.
	For storage	°C	-25...+70
<b>Maximum operating altitude</b>		m	2000 - Above this, derate the power by 0.5% for each additional 100 m.
<b>Operating positions</b>	Without derating		±30° in relation to the vertical
<b>Shock resistance</b>	Conforming to IEC / EN 60 947-4-2		8 gn, 11 ms
<b>Vibration resistance</b>	Conforming to IEC / EN 60 947-4-2		2 gn
<b>Immunity to radioelectric interference</b>	Conforming to IEC / EN 60 947-4-2		Conforming to EN 1000-4-3 level 3
<b>Radiated and conducted emissions</b>	Conforming to IEC / EN 60 947-4-2		Conforming to EN 1000-4-6 level 3
<b>Electrostatic discharge</b>	Conforming to IEC / EN 60 947-4-2		Conforming to EN 1000-4-2 level 3
<b>Immunity to electrical transients</b>	Conforming to IEC / EN 60 947-4-2		Conforming to EN 1000-4-4 level 4
<b>Voltage/current shock wave</b>	Conforming to IEC / EN 60 947-4-2		Conforming to EN 1000-4-5 level 3
<b>Radio frequency emissions</b>	Conforming to IEC / EN 60 947-4-2		According to CISPR11 and EN 55011 Class A

## Output relay characteristics

<b>Rated operating current</b>	Conforming to IEC 947-5-1		Category of use AC-15 : Ie 3 A, Ue 250 V
<b>Rated power of contacts</b>	~ 250 V	VA	2000 (6 A-250 V)
<b>Minimum switching capacity</b>	17 V	mA	10
<b>Conventional thermal current</b>		A	6
<b>Maximum operating voltage</b>	≈ 50/60 Hz	V	250
<b>gi type fuse protection</b>	IEC 947-5-1	A	6



# LH4 Modular Soft Start Characteristics

## Electrical characteristics

Catalog Number		LH4-	N106●●●	N112●●●	N125●●●	N206●●●	N212●●●	N225●●●	N230LY7	N244LY7	N272LY7	N285LY7
Rated operating voltage (Ue)		V	208...240 (LH4-N1●●LU7) 380...415 (LH4-N1●●QN7) 440...480 (LH4-N1●●RT7) (-15...+10% on all values)			208...240 (LH4-N2●●LU7) 380...415 (LH4-N2●●QN7) 440...480 (LH4-N2●●RT7) (-15...+10% on all values)			208...690 - 15...+10%			
Control voltage			internal to the product						115 V 50/60 Hz (~20 VA) external			
Frequency		Hz	50 or 60									
Rated operating current		A	6	12	22	6	12	22	32	44	72	85
Starting time	Voltage ramp		Adjustable from 1 to 5 s						Adjustable from 1 to 25 s			
Stopping time	Voltage ramp					Adjustable from 0 to 5 s			Adjustable from 0 to 25 s			
Starting torque			Adjustable from 0.3 to 0.8 of the direct motor starting torque									
Power loss	At full load at end of starting	W	2	3	3.5	3	4	5	22	22	23	23
	Transient operation	W	20	39	70	40	76	130	184	268	436	514
	Average duty 10%	W	2.5	3.6	4.3	4	6	8	37	44	59	66
Overcurrent protective device (OCPD)	Max fuse	Class	J	J	J	J	J	J	RK5/J	RK5/J	RK5/J	RK5/J
	— Type 1 coordination only	A	20	35	80	20	35	80	100	125	200	250
Starting and stopping current	Max. duty of 360 seconds of starting and stopping per hour	A	18	36	75	18	36	75	90	132	216	255
LED displays			Green lit, device powered up; Yellow lit, starting completed									
Logic inputs									Logic state 1 : I > 10 mA - Logic state 0 : I < 3 mA Voltage supplied by the product 24 V ± 25% (no power available)			

## Connections

Catalog Number		LH4-	N106●●●	N112●●●	N125●●●	N206●●●	N212●●●	N225●●●	N230LY7	N244LY7	N272LY7	N285LY7
Power	(L1/L2/L3 - T1/T2/T3)	AWG (75C)	18...8	18...8	18...8	18...8	18...8	18...8	10...2	10...2	10...2	10...2
Control	(00 - 07)	AWG (75C)	—	—	—	18...12	18...12	18...12	18...12	18...12	18...12	18...12
Ground		AWG (75C)	—	—	—	—	—	—	10...2	10...2	10...2	10...2



# LH4 Modular Soft Start Selection Table

## LH4-N1 Soft Start Modules

50/60 Hz - Single or three phase



LH4-N1●●

208 V HP	230 V HP	380 V kW	460 V HP	575 V HP	Rated Current (1)	Catalog Number
1.5	1.5	3	3	—	6	LH4-N106LU7 LH4-N106QN7 LH4-N106RT7
3	3	5.5	7.5	—	12	LH4-N112LU7 LH4-N112QN7 LH4-N112RT7
7.5	7.5	11	15	—	25	LH4-N125LU7 LH4-N125QN7 LH4-N125RT7

(1) 10% maximum duty cycle - De-rate by one size if more than 360 seconds of start/stopping time per hour is required.

## LH4-N2 Soft Start / Soft Stop Modules

50/60 Hz - Three phase



LH4-N225●●

208 V HP	230 V HP	380 V kW	460 V HP	575 V HP	Rated Current (1)	Catalog Number
1.5	1.5	3	3	—	6	LH4-N206LU7 LH4-N206QN7 LH4-N206RT7
3	3	5.5	7.5	—	12	LH4-N212LU7 LH4-N212QN7 LH4-N212RT7
7.5	7.5	11	15	—	25	LH4-N225LU7 LH4-N225QN7 LH4-N225RT7
—	10	15	20	30	32	LH4-N230LY7
10	15	22	30	40	44	LH4-N244LY7
20	25	37	50	60	72	LH4-N272LY7
25	30	45	60	75	85	LH4-N285LY7

(1) 10% maximum duty cycle - De-rate by one size if more than 360 seconds of start/stopping time per hour is required.



LH4-N244●●



# LH4 Modular Soft Start Dimensions

## LH4-N1 and LH4-N2 — External dimensions

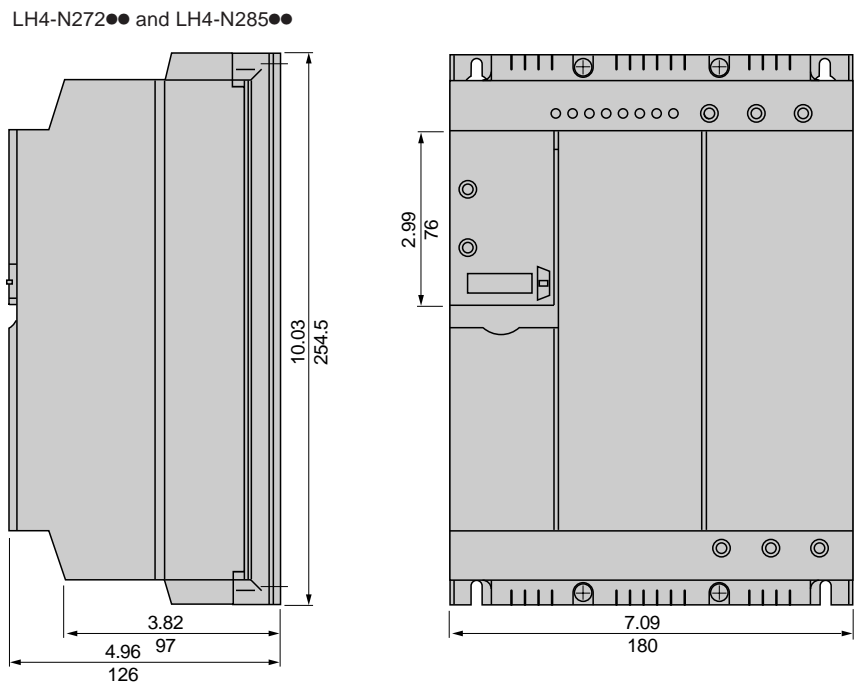
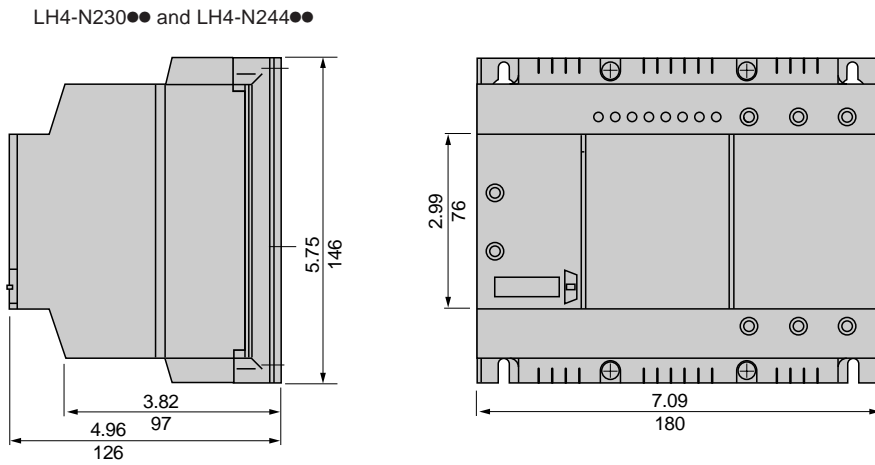
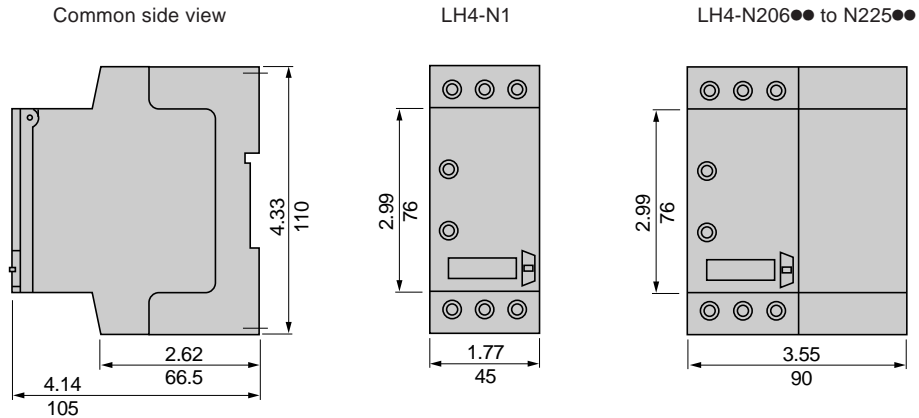

Dual Dimensions: **INCHES**  
Millimeters



# LH4 Modular Soft Start Mounting

## LH4-N1 and LH4-N2 — mounting dimensions

AM1-ED rail mounting (35 mm)  
LH4-N1 or LH4-N206●●...N225●●

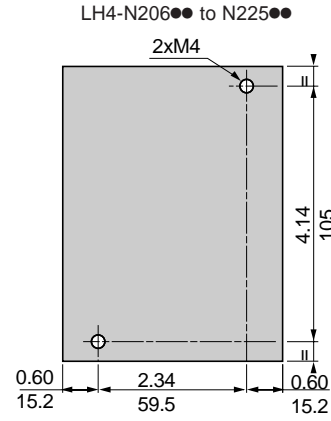
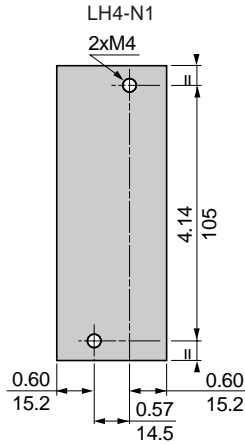
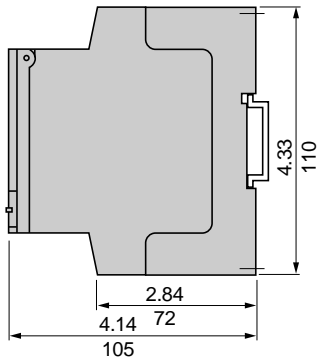

LH4-N230●● and LH4-N244●●

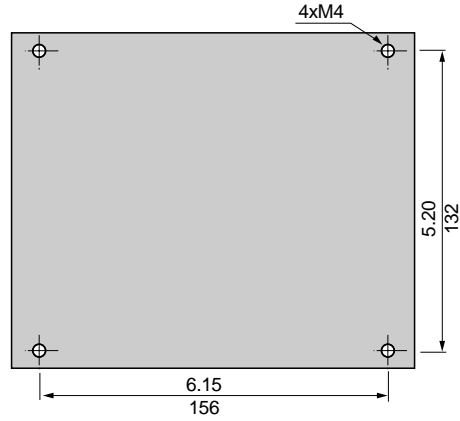
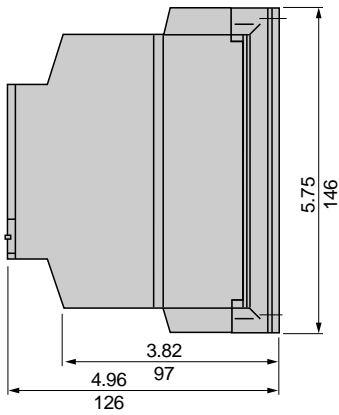

LH4-N272●● and LH4-N285●●

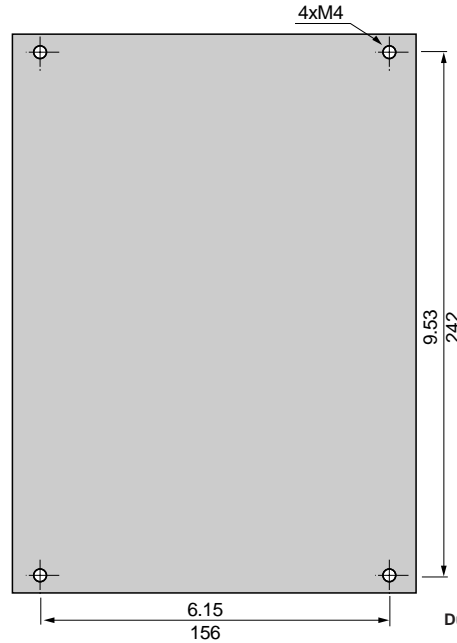
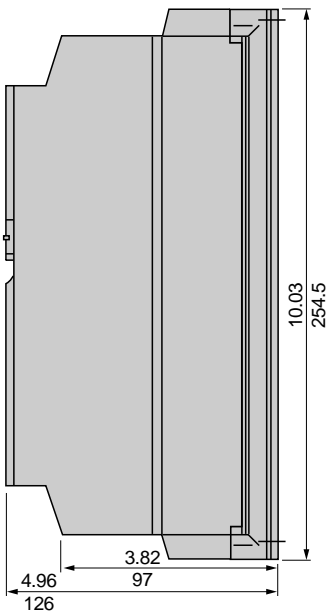

Dual Dimensions: **INCHES**  
Millimeters





# LH4 Modular Soft Start Recommended Wiring Schemes

## LH4N Soft Start Units — 25 amps and below

### LH4-N1 only

Soft start only with manual motor starter, single-phase motor

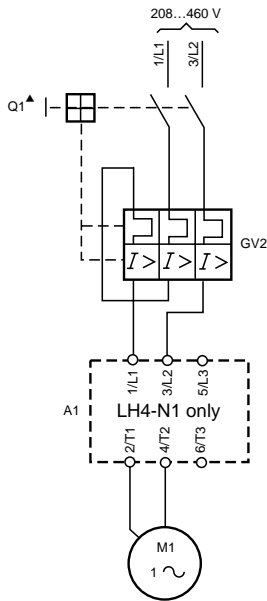

### LH4-N1 only

Soft start only with line contactor, single-phase motor

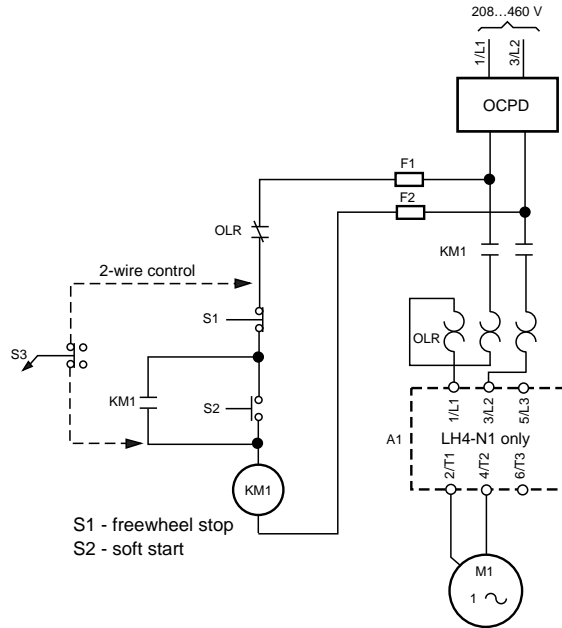

### LH4-N1 and LH4-N2

Soft start only with manual motor starter, 3-phase motor

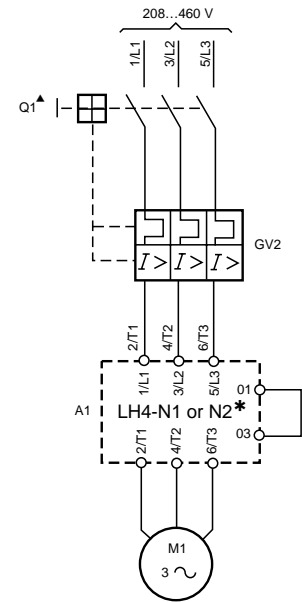

▲ When using manual motor controller (GV2) overcurrent protection must be provided in accordance with applicable installation code.

### LH4-N1 and LH4-N2

Soft start only with line contactor, 3-phase motor

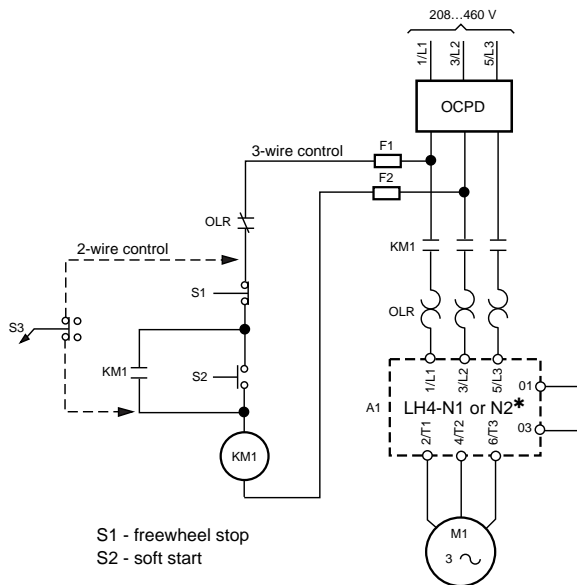

### LH4-N1 and LH4-N2

Soft start only with line contactor, reversing motor

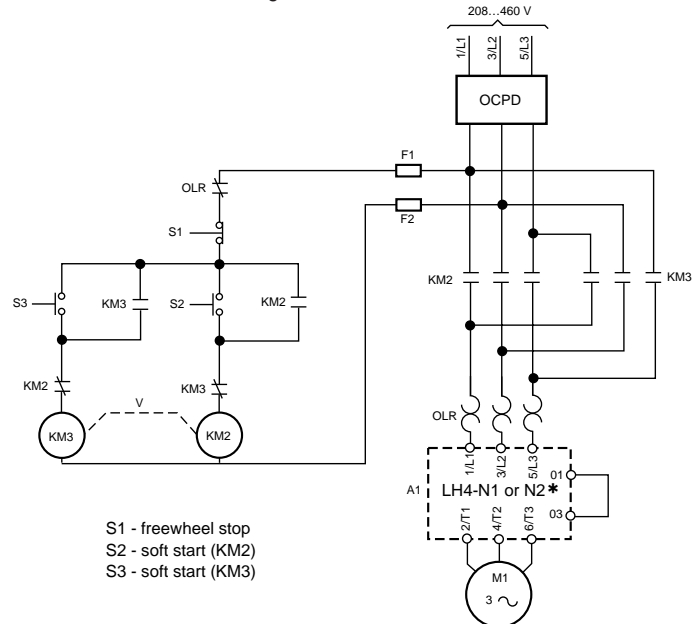

\* NOTE: On LH4-N2 units, connection from terminal 01 to 03 is required for soft start ramp. Connection is not required on LH4-N1 devices.

OCPD: Overcurrent Protective Device—size per applicable codes and standards.



# LH4 Modular Soft Start Recommended Wiring Schemes

## LH4-N2 Soft-start / Soft-stop units — 25 amps and below

### LH4-N2 only

Soft start / soft stop with line contactor

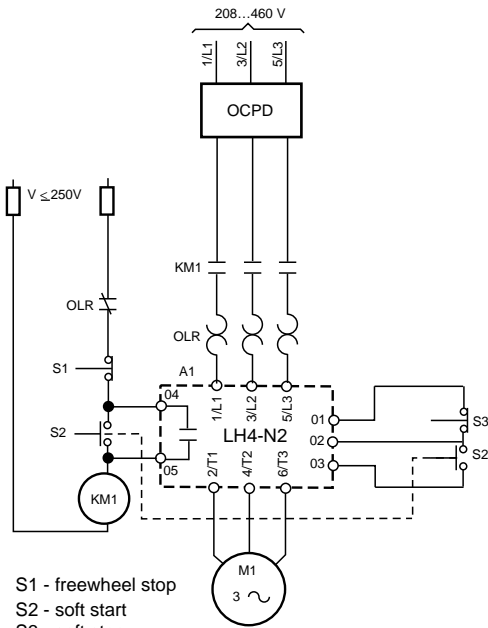

S1 - freewheel stop  
S2 - soft start  
S3 - soft stop  
04/05 - hold-in / fault contact for soft stop

### LH4-N2 only

Soft start only with line contactor and hold-in feature. \*

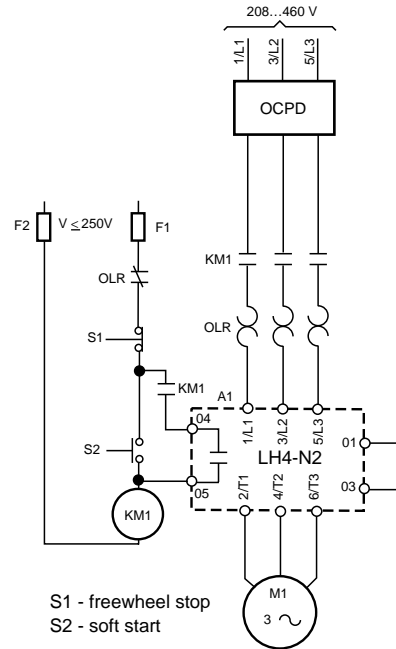

S1 - freewheel stop  
S2 - soft start

\* After a start command, hold-in relay will de-energize after the stop ramp is timed out or a fault of the LH4N module is detected.



# LH4 Modular Soft Start Recommended Wiring Schemes

## LH4-N2 Soft-start / Soft-stop units — 32 amps and above

Soft start only with GV2, GV3 and GV7 manual motor starter  
LH4-N230LY7...LH4-N285LY7

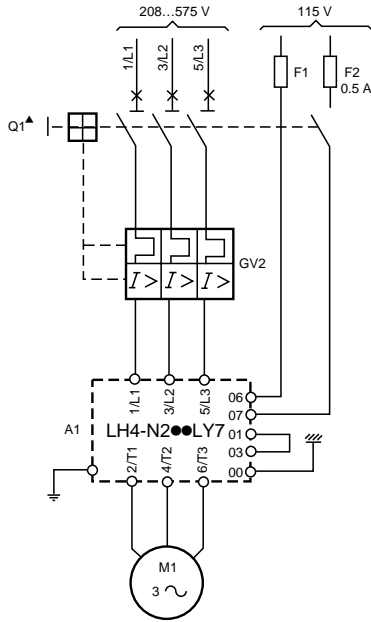

Soft start only with line contactor  
LH4-N230LY7...LH4-N285LY7

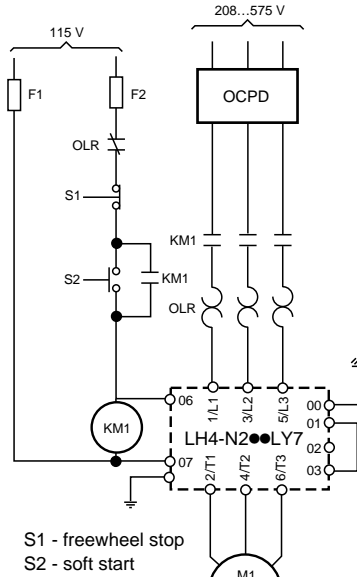

S1 - freewheel stop  
S2 - soft start

▲ When using manual motor controller (GV2) overcurrent protection must be provided in accordance with applicable installation code.

Soft start / soft stop with line contactor  
LH4-N230LY7...LH4-N285LY7

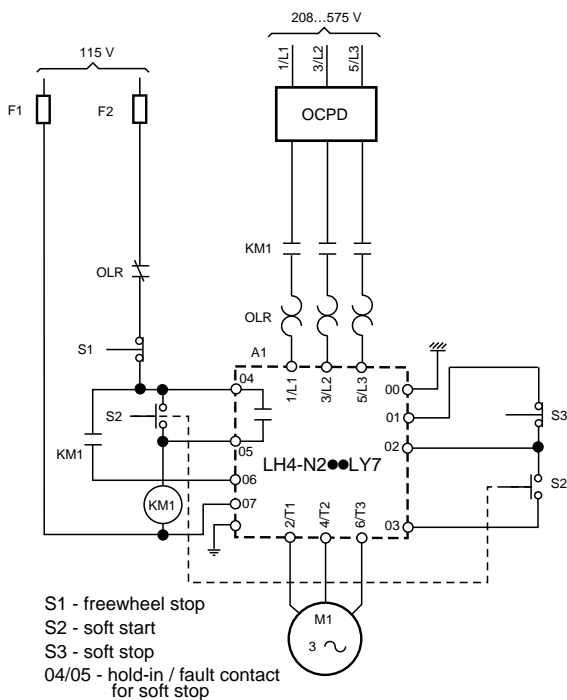

S1 - freewheel stop  
S2 - soft start  
S3 - soft stop  
04/05 - hold-in / fault contact  
for soft stop

Soft start only, reversing motor  
LH4-N230LY7...LH4-N285LY7

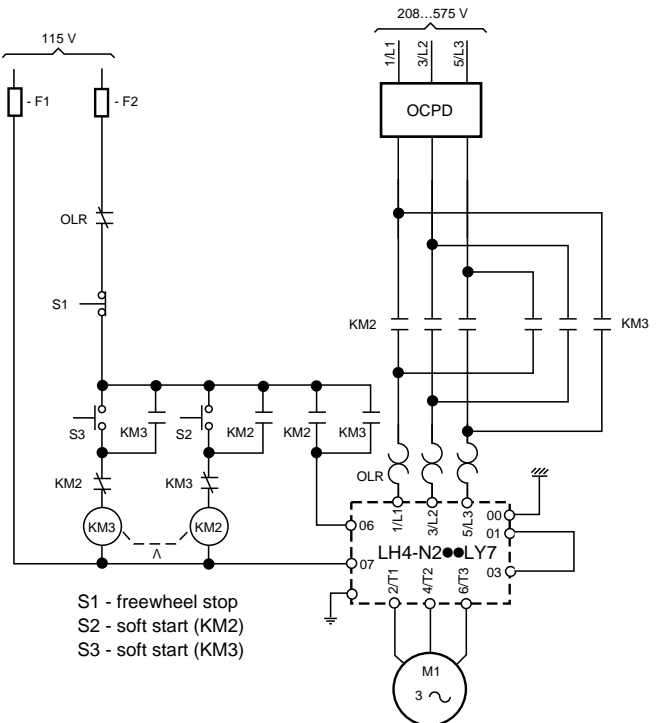

S1 - freewheel stop  
S2 - soft start (KM2)  
S3 - soft start (KM3)

# LH4 Modular Soft Start Recommended Components

## List of recommended components (7)

M1 Motor					A1 Soft start module (1)	Q1 Manual motor starter (3)	KM1 Isolation Contactor (4)	KM2-KM3 Reversing Contactor (4)	OLR Overload Relay (5)	F1-F2 Control Fuses
208V HP	240V HP	400V kW	480V HP	575V HP						
0.5	0.5	0.75	1	—		GV2-M07			LR2-K0308	
1	1	1.1	1.5	—	LH4N●06●●● (2)	GV2-M08	LC1-K0610●●	LC2-K0610●●	LR2-K0310	(6)
1.5	1.5	2.2	3	—		GV2-M10			LR2-K0312	
2	2	4	5	—		GV2-M14				
					LH4N●12●●● (2)		LC1-K0910●●	LC2-K0910●●	LR2-K0316	(6)
3	3	5.5	7.5	—		GV2-M16				
5	5	7.5	10	—		GV2-M20	LC1-D1810●●	LC2-D1801●●	LR2-D1321	
					LH4N●25●●● (2)					(6)
7.5	7.5	11	15	—		GV2-M22	LC1-D2510●●	LC2-D2501●●	LR2-D1322	
-	10	15	20	30	LH4-N230LY7	GV2-M32	LC1-D3201●●	LC2-D3201●●	LR2-D3355	0.5 amp
10	15	22	30	40	LH4-N244LY7	GV2-M53	LC1-D5011●●	LC2-D5011●●	LR2-D3357	0.5 amp
15	20	22	40	50		GV3-M63	LC1-D6511●●	LC2-D6511●●	LR2-D3359	
					LH4-N272LY7					0.5 amp
20	25	37	50	60		GV3-M80	LC1-D80●●	LC2-D80●●	LR2-D3361	
25	30	45	60	75	LH4-N285LY7	GV3-RE100	LC1-F115●●	LC2-F115●●	LR9F5367	0.5 amp

- (1) Ratings are for 10% duty cycle (soft start + soft stop time not to exceed 360 seconds per hour). Above this, derate soft start by one size.
- (2) Complete the LH4N soft start module part number per the table on page 5.
- (3) Select branch circuit protection per applicable installation codes.
- (4) Add coil voltage per IEC contactor catalog or refer to the Square D Product Digest for additional information.
- (5) The thermal overload relay has been selected to provide Class 10 protection. If this does not allow starting to be completed, select the overload protection within the NEC guidelines for across the line starting.
- (6) To be sized based on the line/control voltage.
- (7) Adaptable sub assemblies XB2-B or XB2-M can be used for control operators S1-S2-S3. Refer to the Square D Product Digest for additional information.



## LH4-N1 — ALL MODELS

No external control connections are provided on LH4-N1 devices. A transformer connected internally provides the soft start module with control power. The soft start ramp begins when voltage is present on the line side terminals. These units can only operate at the line voltage for which they are rated.

## LH4-N2 — 6,12, AND 25 AMP MODELS

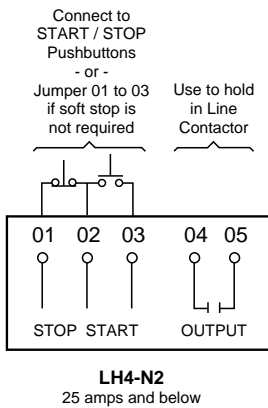

The LH4-N2 devices rated 25 amps and below are provided with control terminals 01 to 05. Terminals 01, 02, and 03 are used to provide the user with a choice of freewheel or soft stop. In order to begin the soft start ramp, both line voltage and a connection from terminals 01 to 03 must be present. The start signal may be maintained—as shown when soft stop is not required—or instantaneous, as shown for control with soft stop.

A normally open seal in / fault relay is provided between terminals 04 and 05. These terminals should be used to keep the line contactor energized after a stop command for the duration of the soft stop ramp or to drop out the line contactor if the soft start module is damaged. The LH4N has internal fault detection only and does not provide protection from motor or line faults.

Control power for the LH4-N2 devices rated 25 amps and below are provided by an internally connected transformer. These units can only operate at the line voltage for which they are rated.

## LH4-N2 — 32, 44, 72, AND 85 AMP MODELS

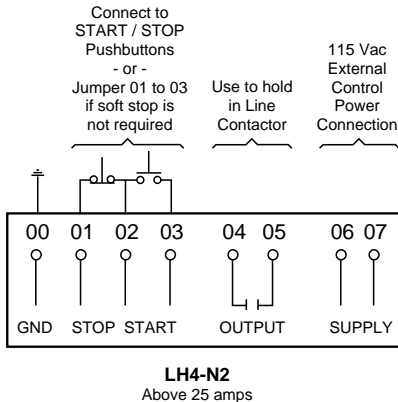

The LH4-N2 devices rated above 25 amps are provided with control terminals 00 to 07. Terminal 00 is a control power ground that should be connected to ground. Terminals 01 to 05 are the same as described for the devices rated 25 amps and below.

Terminals 06 and 07 are for connection to externally supplied 115 Vac control power. The soft start ramp will begin when control power and a connection between terminal 01 and 03 are present. Apply control power upon a start command by connecting to terminals 06 and 07 in parallel with the line contactor coil. This is shown in the recommended wiring diagrams on pages 9 to 11.

An up-to-speed relay can be added to the side of the LH4-N2 units rated above 25 amps. Auxiliary relay LA8-DN●● must be ordered separately for mounting on the bypass contactor.



# LH4 Modular Soft Start

## Application Notes, Support Information, and Warranty

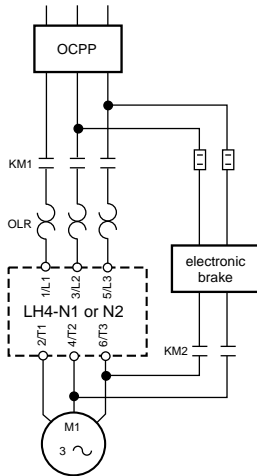

### APPLICATION NOTES

- The LH4-N1 soft start module reduces the voltage in one phase during the acceleration ramp. When starting a lightly loaded motor, or motor spinning in the reverse rotation, either increase the initial torque adjustment or use the LH4-N2 version to guarantee the direction of initial rotation.
- Consult the motor manufacturer when applying the LH4-N1 soft start with a single phase motor, as some single phase motors are already designed for soft starting with line voltage applied.
- The LH4N modular soft start can be used with a solid state overload relay. The phase imbalance protection may have to be disabled to allow starting without nuisance tripping.
- The LH4N modular soft start may be used with an electronic brake as shown in the diagram at left.

### SUPPORT

#### Product Support Group — Troubleshooting

The Product Support Group is available 24 hours a day, 365 days a year. They will work with you over the phone to diagnose product problems and advise the correct course of action.

Phone: 919-217-6535 press "3"  
Fax: 919-217-6508  
E-mail: drivespsg.raleigh@squared.com

#### Square D Field Service

The Square D Field Services division is committed to providing quality on-site service that consistently meets customer expectations. The Field Services Coordination Center responds to your requests, seven days a week, 24 hours a day.

Phone: 800-634-2003

#### D-FAX Fax-On-Demand Service

The D-FAX™ service from Square D provides immediate access to information. The automated voice attendant will guide you through the process and you will receive the information on your fax machine within minutes. Please refer to the D-FAX reference numbers in the catalog.

Phone: 800-557-4556

#### Square D Website

Visit the virtual work zone at the Square D website. It offers a variety of solutions for your drive and soft start applications. It also includes software tools, new product information, and product selection information.

Web Address: <http://www.squared.com>

### WARRANTY

#### Warranty to customers purchasing through authorized Square D distributors and customers purchasing directly from Square D.

Square D warrants equipment manufactured by it to be free from defects in materials and workmanship for eighteen months from date of invoice from Square D or its authorized sales channel. If within the applicable warranty period purchaser discovers such item was not warranted and promptly notifies Square D in writing, Square D shall repair or replace the items or refund the purchase price, at Square D's option. This warranty shall not apply (a) to equipment not manufactured by Square D, (b) to equipment which shall have been repaired or altered by others than Square D, (c) to equipment which shall have been subjected to negligence, accident, or damage by circumstances beyond Square D's control, or to improper operation, maintenance or storage, or to other than normal use or service. With respect to equipment sold but not manufactured by Square D, the warranty obligations of Square D shall in all respects conform and be limited to the warranty actually extended to Square D by its supplier. **The foregoing warranties do not cover reimbursement for labor, transportation, removal, installation, or other expenses which may be incurred in connection with repair or replacement.**

Except as may be expressly provided in an authorized writing by Square D, Square D shall not be subject to any other obligations or liabilities whatsoever with respect to equipment manufactured by Square D or services rendered by Square D.

**The foregoing warranties are exclusive and in lieu of all other express and implied warranties except warranties of title, including but not limited to implied warranties of merchantability and fitness for a particular purpose.**



## LH4 Modular Soft Start Soft Start and Reduced Voltage Starter Overview



### ALTISTART® 46

The ALTISTART 46 soft start introduces the principal of “Torque Control System” (TCS) ramping. Basing the acceleration on the motor rather than applying a voltage ramp or maintaining a current limit (as used in traditional soft starts) provides a linear speed ramp— independent of motor loading—without tach feedback.

There are 21 power ratings from 17 to 1200 A.  
Each can be configured for 208/230/380/460 V, 50/60 Hz.

Catalog # 8636CT9701  
Brochure # 8636HO9701  
D-FAX # 23



### Class 8636 — ALTISTART 46 Non-Combination Enclosed Class 8638 — ALTISTART 46 Combination Enclosed Fusible Class 8639 — ALTISTART 46 Combination Enclosed Circuit Breaker

A family of enclosed soft start controllers is available through 500 hp for easy integration of the ALTISTART 46 into industrial facilities. The Class 8638 and 8639 combination style soft starts combine the requirements of motor overload and short circuit protection in a Type 12 enclosure, and are available for reversing and non-reversing applications.

Catalog # 8636CT9701  
D-FAX # 23



### LH4N

The LH4N soft starter module allows gradual starting and stopping of single and three phase motors. Unlike conventional electromechanical starting systems, the LH4N provides precise adjustment of the motor torque which eliminates mechanical shocks. The LH4N is designed for installation downstream from a motor starter circuit which includes a power contactor and approved motor overload and short circuit protection.

6 A to 85 A — 208/240/380/460/575 V

Catalog # 8637CT9701  
Brochure # 8637HO9701  
D-FAX # 23



### Electromechanical Reduced Voltage Starters

#### Class 8606 — Autotransformer Starter Class 8630 — Wye Delta Starter Class 8640 — Part Winding Starter

Square D offers a full line of Electromechanical Reduced Voltage Starter products to minimize the electrical and mechanical stresses caused by across the line starting.

Catalog # 8600CT9601  
D-FAX # 23



Square D Company  
8001 Highway 64 East  
Knightdale, NC 27545-9032  
919-266-3671

Square D and  are registered trademarks of Square D Company.

Catalog No. 8637CT9701R7/98 July1998 © 1998 Square D All Rights Reserved.