

Overload Relays and Thermal Unit Selection

Class 9065



CONTENTS

Description	Page
General Information	2-10
Application Data	11-14
Approximate Dimensions and Weights	15-17
Thermal Unit Selection	18-42



SQUARE D
GROUPE SCHNEIDER

Product Description

INTRODUCTION

Overload relays are intended to protect motors, controllers, and branch-circuit conductors against excessive heating due to prolonged motor overcurrents up to and including locked rotor currents. Protection of the motor and the other branch-circuit components from higher currents, due to short circuits or grounds, is a function of the branch-circuit fuses, circuit breakers, or motor short-circuit protectors.

Electrical motors make up a large percentage of power system loads. Market demands for reduced downtime and increased productivity have compelled the motor control industry to evaluate motor protection technology continuously. Technology advancements now allow the motor control industry to offer several options for motor protection.

This briefly reviews traditional motor protection technologies and discusses the new, electronic motor protection options. After reading this paper, you should be able to understand the available technologies and how to choose the right solution for a given application. Important factors to consider in determining the appropriate overload protection include:

- Application requirements
- Cost per feature of a given technology
- Willingness and ability of all parts of the user's organization to embrace and implement the new technology.

MOTOR FAILURE AND PROTECTION

Motor failure may be the result of electrical or mechanical factors. A study commissioned by the Electrical Research Associates (ERA) of the United Kingdom in 1986 indicated the most common causes of motor failure are:

- | | |
|-------------------------|-----|
| 1. Overcurrent | 30% |
| 2. Contamination | 18% |
| 3. Single Phasing | 15% |
| 4. Bearing Failure | 12% |
| 5. Aging (natural wear) | 10% |
| 6. Rotor Fault | 5% |
| 7. Miscellaneous | 7% |

Failure modes 1, 3 and 7 are attributable to electrical issues. Modes 2, 4, 5 and 6 are the result of mechanical (and some manufacturing) issues.

Historically, motor protection provided with the controller was only able to address the electrical causes of motor failure. These electrical issues account for at least 45% of the most common causes of motor failure. Motor branch circuits are protected against short circuits (instantaneous overload currents) and steady state or low level, sustained overload relays. In the U.S., this protection is provided by the short circuit protective device (SCPD) and the motor overload relay, when they are applied according to the National Electrical Code (NEC).

Trip Class Designation

Regardless of the product style (NEMA or IEC), overload relays respond to overload relay conditions according to trip curves. These trip curves are defined by the class of protection required (see Table 1).

Table 1: Trip Classes

Class Designation▲	Tripping Time
Class 10	10 Seconds or less
Class 20	20 Seconds or less
Class 30	30 Seconds or less

▲ Marking designation for tripping time at 600% of current element rating



IEC components are typically application rated. This means the controller is sized very close to its operational limit for a given application. IEC motors are also generally more application rated. For these reasons, Class 10 trip is most common on IEC applications. Because NEMA products are applied with more built-in excess capacity, the Class 20 trip is most common.

Figure 1 shows the three types of trip curves.

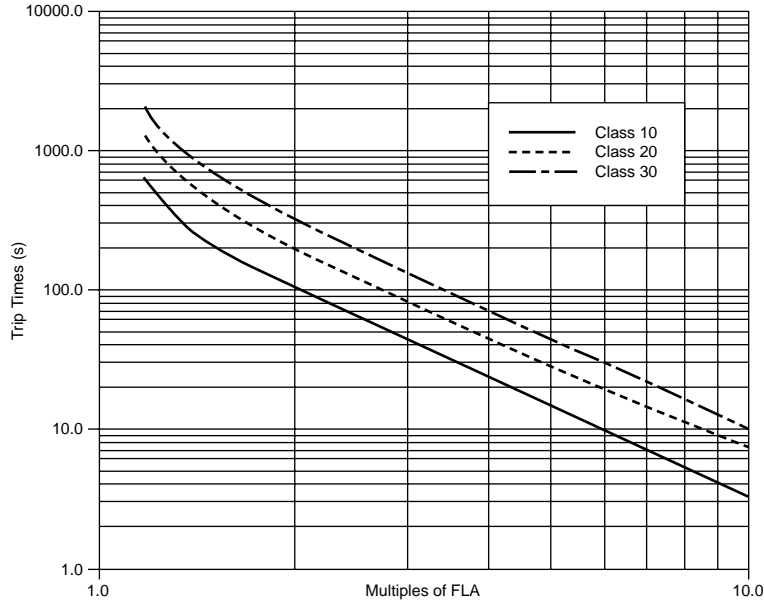

Figure 1 Typical Trip Curves

Protection to Motor Branch Circuits

To protect the motor branch circuit against short circuits, overload relay protection must be coordinated with protection provided by the SCPD. The SCPD may be a fused switch or a circuit breaker. Figure 2 shows the critical point (I_c) in this coordination.

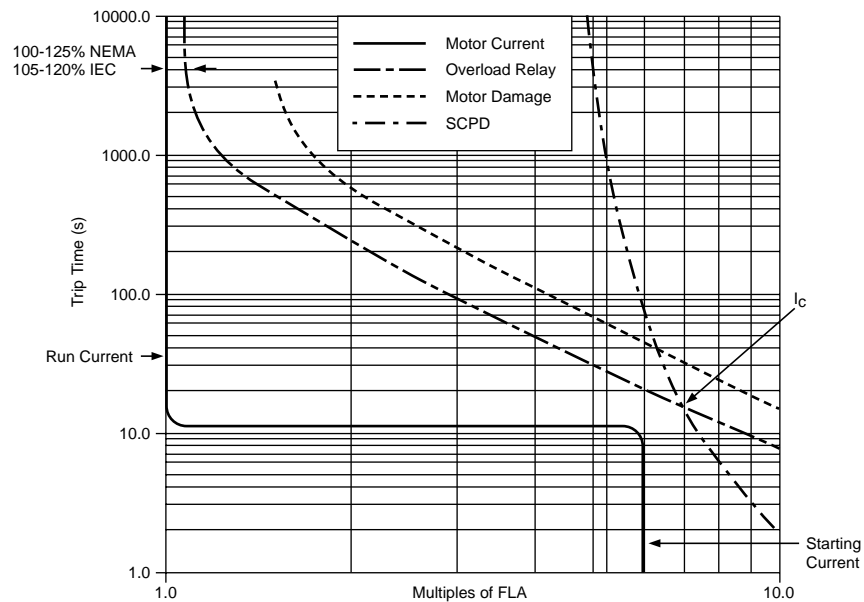
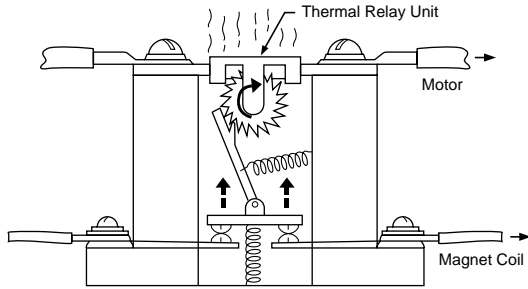

Figure 2 Typical Coordination Curves



Product Description



Drawing shows operation of melting alloy overload relay. As heat melts alloy, ratchet wheel is free to turn. The spring then pushes contacts open.

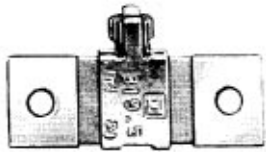

One Piece Thermal Unit

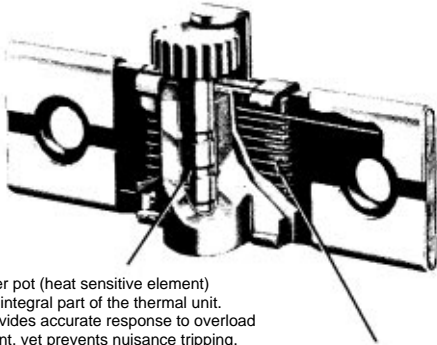

Solder pot (heat sensitive element) is an integral part of the thermal unit. It provides accurate response to overload current, yet prevents nuisance tripping.

Heating winding (heat producing element) is permanently joined to the solder pot, so proper heat transfer is always insured. No chance of misalignment in the field.

Melting Alloy Thermal Unit

At current values greater than I_c , the SCPD reacts quicker than the overload relay. At current values less than I_c , the overload relay reacts quicker. Articles 110 and 430 of the NEC provide guidance in the selection of the SCPD to facilitate coordination of the components of a motor branch circuit (i.e. location of point I_c).

Withstand Ratings

Equipment withstand ratings are linked to branch circuit protection. The same parameters that affect the trip point of a given protective device also contribute to how much (or how little) let-through energy the device may be exposed to and still function after the clearing of the fault. Withstand does not explicitly show up in Figures 1 or 2. Traditional melting alloy and bi-metal overload relays have been the “weak link” in motor branch circuit withstand ratings. Since these devices employ sensing elements directly in the current path, electrical faults leading to mechanical stresses are a concern. These devices typically contain small mechanical parts that can quickly become out-of-spec when exposed to let-through energy exceeding their withstand capability. If the coordinated protection for the circuit operates properly (and the SCPD protects the circuit), the motor and the controller will be protected. The withstand rating of a branch circuit must account for the withstandability of the lowest rated component in the circuit.

Thermal Overload Relay

In spite of being relatively simple and inexpensive, thermal overload relays are very effective in providing motor running overcurrent protection. This is possible because the most vulnerable part of most motors is the winding insulation and this insulation is very susceptible to damage by excessively high temperature.

Being a thermal model of a motor, the thermal overload relay will produce a shorter trip time at a higher current similar to the way a motor will reach its temperature limit in a shorter time at a higher current. Similarly, in a high ambient temperature, a thermal overload relay will trip at a lower current or vice versa allowing the motor to be used to its maximum capacity in its particular ambient temperature (if the motor and overload are in the same ambient).

Once tripped, the thermal overload relay will not reset until it has cooled, automatically allowing the motor to cool before it can be re-started.

NOTE: The overload relay must be used in conjunction with a contactor. The overload relay has no power contacts and cannot disconnect the motor by itself. The control circuit contact must be wired in series with the coil of the contactor so that the contactor will de-energize when an overload occurs.

Square D manufactures three types of overload relays, the melting alloy, the bimetallic, and solid state. In some types, the bimetallic is available in both non-compensated and ambient temperature-compensated versions. In both melting alloy and bimetallic, single element and three element overloads are available. Solid state overloads are discussed on Page 5.

Melting Alloy

In melting alloy thermal overload relays, the motor current passes through a small heater winding. Under overload conditions, the heat causes a special solder to melt allowing a ratchet wheel to spin free thus opening the control circuit contacts. When this occurs, the relay is said to “trip”. To obtain appropriate tripping current for motors of different sizes, or different full load currents, a range of thermal units (heaters) is available. The heater coil and



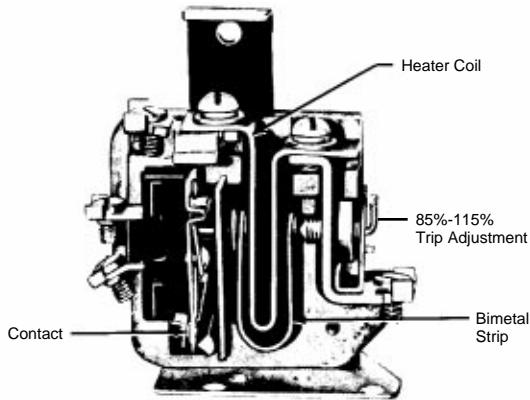

Bimetallic Overload Relay with Side Cover Removed

solder pot are combined in a one piece, nontamperable unit. Melting alloy thermal overload relays must be reset by a deliberate hand operation after they trip. A reset button is usually mounted on the cover of enclosed starters. Thermal units are rated in amperes and are selected on the basis of motor full load current, not horsepower.

Non-Compensated Bimetallic

Bimetallic thermal overload relays employ a U-shape bimetal strip associated with a current carrying heater coil. When an overload occurs, the heat will cause the bi-metal to deflect and operate a control circuit contact. Different heaters give different trip points. In addition, most relays are adjustable over a range of 85% to 115% of the nominal heater rating.

Bimetallic overload relays are used where the controller is remote or difficult to reach. Three wire control is recommended when automatic restarting of a motor could be hazardous to personnel.

Automatic Reset

These relays are field convertible from hand reset to automatic reset and vice-versa. On automatic reset after tripping the relay, contacts will automatically reclose when the relay has cooled down. This is an advantage when the relays are inaccessible. However, automatic reset overload relays should not normally be used with 2-wire control. With this arrangement, the motor will restart when the overload relay contacts reclose after an overload relay trip, and unless the cause of the overload has been removed, the overload relay will trip again. This cycle will repeat and eventually the motor will burn out due to the accumulated heat from the repeated inrush and overload current. More important is the possibility of danger to personnel. The unexpected restarting of a machine may find the operator or maintenance man in a hazardous situation as he attempts to find out why his machine has stopped.

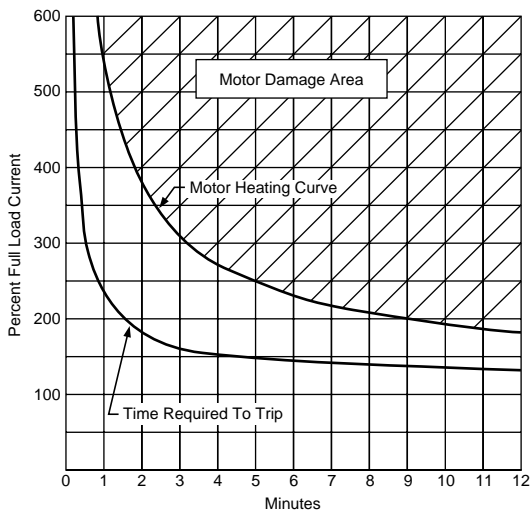

Graph shows motor heating curve and overload relay trip curve. Overload relay will always trip at a safe value.

Overload Relay Trip Curve

Ambient Temperature Compensated Bimetallic

Ambient-compensated bimetallic overload relays are designed for one particular situation; that is, when the motor is at a constant ambient temperature and the controller is located separately in a varying ambient temperature. In this case, if a standard thermal overload relay were used, it would not trip at the same level of motor current if the controller temperature changed. The standard thermal overload relay is always affected by the surrounding temperature. To compensate for temperature variations, an ambient-compensated overload relay is used. Its trip point is not affected by temperature, and it performs consistently at the same value of current.

Thermal Overload Relay Trip Characteristics

Melting alloy and bimetallic overload relays are designed to approximate the heat actually generated in the motor. As the motor temperature increases, so does the temperature of the thermal unit. The motor and relay heating curves (left) show this relationship. From this graph we can see that no matter how high the current drawn, the overload relay will provide protection yet will not trip unnecessarily.

Solid State Overload Relay

There are some substantial advantages to using the solid state electronic device. The device does not require thermal units. The customer does not have to exercise skill at the selection procedure nor is there a need to stock



Product Description

thermal units for repair or replacement. Not having to install thermal units can save from 20-30% of the installation time for a starter or separate overload relay, as compared to the traditional NEMA devices.

The solid state device, when operated within its operating temperature range, does not require ambient compensation. Only the level of current being drawn by the motor affects the trip of the device.

Solid state devices are typically available as part of a starter or as a separate component. This adds to the flexibility of their application and mounting. Some solid state devices are designed to retrofit melting alloy or bi-metal devices from the same manufacturer. This flexibility provides the user a migration path to the new technology. Product selection and application are not dramatically different from the traditional melting alloy or bi-metal devices. The mounting and "look" are also similar to the traditional devices. Backward compatibility can also be useful if the decision is made to standardize on the new technology and the user wishes to upgrade the existing installed base.

The most important feature offered by a solid state overload relay is phase loss protection. While a phase loss causes a significant current increase in the remaining phases of the motor circuit, there is a major increase in rotor current that can cause motor damage.

The time it takes for a melting alloy device to trip is determined only by the level of current in the remaining phases. The majority of the motors installed (world-wide) are run at about 70% of their full load capability. In these situations, the phase loss condition may result in a level of current in the remaining phases just slightly above the actual FLA of the motor and, therefore, only slightly above the rating of the thermal unit. Therefore, it could take a substantial amount of time for the melting alloy device in this application to respond to phase loss.

The bi-metal device offers a limited form of phase loss protection by means of a differential tripping mechanism where the device will trip somewhat faster when an overload is detected on only two of the phases. This device contrasts with a solid state overload relay with phase loss protection that would trip in less than three seconds and alert the user of a potential distribution system problem in advance of motor failure. Consequently, the problem does not have an opportunity to affect other equipment on the system.

The solid state device also provides phase unbalance protection where the device will trip if the current on any phase is 25% greater than the average of all three phases. Phase unbalances are typically caused by an unbalanced up-stream single phase load that can disturb phase voltages. Such a condition can similarly lead to excessive rotor currents and motor damage.



Thermal Overload Relays – NEMA Rated Melting Alloy

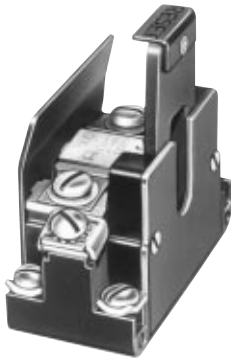

Type CO1R

NEMA-rated Thermal Overload Relays feature:

- Exclusive One-Piece Thermal Unit
- Inverse Time Delay Trip
- Alarm Contact Available
- Trip Free Reset Mechanism on Types F, G & S
- Replaceable Contact Units on Types F, G & S

Slow trip (Class 30) and quick trip (Class 10) melting alloy thermal units are available for all Size 1, 2, 5 and 6, and some Size 3 and 4 applications. Thermal units are not included.

For Separate Mounting – Melting Alloy – 600 Volts Maximum, AC or DC*

Size	Maximum Full Load Current (Amperes)	Open Type for Separate Panel Mounting		For Terminal Block Channel Mounting Order
		Left Hand Type	Right Hand Type	Type
Single Pole Construction (One N.C. Contact) — 1 Thermal Unit Required				
1	25	CO1	CO1R	...
2	45	TO1	TO1	...
3	86	UO1	UO1	...
4	133	FO1L	FO1R	...
5	266	GO11L	GO11R	...

Three Pole Construction (One Common N.C. Contact on Type S Only) — 3 Thermal Units Required

1	25	SEO5	SM2
2	45	SEO8	SM2
3	86	SEO12	...
4	133	SEO15	...
5	266	Use 3 Type GO11R Relays Listed Above	

* Maximum power circuit rating for separate mounting overload relays, Types C, F, G, T and U, is 600 volts AC or DC; Type S is 600 volts AC only. Maximum control circuit contact rating for Types C, F, G, T, U and SDO18 is 600 volts AC and 250 volts DC; the remaining Type S versions are 600 volts AC only.



Type SEO5

Replacement Melting Alloy Overload Relays for Square D Class 8536 Starters

Locate Class 8536 Starter in this Column				Order Class 9065 Overload Relay from this Column	
NEMA Size	Type	Series	Number of Poles	Type	Number of Thermal Units Required
00	SA	A & B	2 3	SDO4 SDO5	1 3
0	SB	A	2 3-5	SDO4 SDO5	1 3▲
1	SC	A	2 3-5	SDO4 SDO5	1 3▲
1P	SC	A	2	SDO10	1
2	SD	A	2 3-5	SDO7 SDO8	1 3▲
3	SE	A	2	SDO11	1
			3	SDO12	3
			4	SDO13	2
			5	SDO14	3
4	SF	A	3	SDO15	3
			4	SDO16	2
			5	SDO17	3
5	SG	A	3‡	SDO18	1
6	SH	A & B	3	SEO5	3

▲ For 4-pole starters used on two phase systems order 2 thermal units plus one Class 9998 Type SO31 jumper strap kit for every two starters. Each kit includes two jumper straps.

‡ Type S Size 5 starters use three Type SDO18 overload relays per starter.

Special Features for Melting Alloy Types

	Form
Substitute 1-N.O. isolated alarm contact and 1-N.C. contact per relay. (Type S starters only)▼	Y342▼
Substitute 2-N.C. contacts for standard N.C. contact per relay. (Type S starters only)	Y344▼
Modify Type U relay to accept Type FB quick trip or SB slow trip thermal units. (Accepts Type C standard trip)	Y21●
Modify Type SDO12 relays to accept Type FB quick trip or SB slow trip thermal units, and Type F, and Type SDO15 relays to accept Type FB quick trip thermal units. (Rejects Type CC standard trip units)	Y81●

● This form cannot be field modified.

▼ Field modification possible. Order 9999 S04 (for Form Y342) or 9999 S05 (for Form Y344).



Thermal Overload Relays – NEMA Rated Bimetallic



**Class 9065
Type SEO6B2
Three Pole Construction
Non-Compensated**

Bimetallic thermal overload relays feature automatic reset or hand reset and a trip-free mechanism. There are ambient temperature-compensated versions. Note that thermal units are not included in the shown prices.

For Separate Mounting – Bimetallic – 600 Volts Maximum AC or DC*

Description	Size	Maximum Full Load Current (Amperes)	Open Type for Separate Panel Mounting	Number of Thermal Units Required
Single Pole Construction (One N.C. Contact)				
Non-Compensated	00, 0, 1	25	DA GA HA JA	1
	2	60		
	3	100		
	4	180		
Three Pole Construction (One Common SPDT Contact on Type S)				
Non-Compensated	1	26	SEO6B2 SEO9B2	3
	2	45		
Ambient Temperature-Compensated	1	26	SEO6B SEO9B	3
	2	45		
For additional selections see International Control Products.				

* Maximum control circuit contact rating for Type S versions is 600 volts AC only.

Replacement Overload Relay for Square D Class 8536 Bimetallic Overload Relay on an Existing Starter

Locate Class 8536 Starter in this Column					Order Class 9065 Overload Relay from this Column	
NEMA Size	Type	Series	Number of Poles	Form	Type	Number of Thermal Units Required
0	SB	A & B	Any	B▲	SDO6B	3
				B1▲	SDO5B1	2
				B2▲	SDO6B2	3
1	SC	A & B	Any	B▲	SDO6B	3
				B1▲	SDO5B1	2
				B2▲	SDO6B2	3
2	SD	A	Any	B▲	SDO9B	3
				B1▲	SDO8B1	2
				B2▲	SDO9B2	3
3	SE	A	3	Y59●	26005-11000	1
		A	3	B5●	SHA01	3
		B			26005-31000	1
4	SF	A	3	Y59●	26005-11500	1
		A	3	B5●	SJA01	3
		B			26005-31800	1
5	SG	A	3	B2Y500▼	SEO6B2	3
				BY500▼	SEO6B	3
6	SH	A & B	3	B	SEO6B	3
				B2	SEO6B2	3

▲ B indicates ambient temperature-compensated bimetallic overload relay.

B1 indicates single phase non-ambient temperature compensated bimetallic overload relay.

B2 indicates polyphase non-ambient temperature compensated bimetallic overload relay.

● Form B5 and Form Y59 use 1 overload relay block per phase. B5 indicates single phase bimetallic overload relay. Y59 indicates single phase ambient temperature compensated bimetallic overload relay.

▼ B2Y500 indicates bimetallic overload relay with current transformer sensing. BY500 indicates ambient temperature compensated bimetallic overload relay with current transformer sensing. This part number does not include the current transformer assembly (Current Transformer part number 31102-084-50).



Thermal Overload Relays – NEMA Rated Solid State Overload Relay, Motor Logic™ Base Unit

Base Unit relays feature: 3 to 1 adjustment range for trip current; phase loss and unbalance protection; direct replacement for Type S melting alloy; and LED power indication. They are ambient insensitive and self-powered. Electrical remote reset is also available.

Base Unit: For Separate Mounting Solid State Overload Relay 600 Volts AC Maximum

Size (3-Pole)	Full Load Current Range (Amperes)	Open Type	
		Trip Class 10	Trip Class 20
00 _C ■	3-9	SSC10	SSC20
0■	6-18	SS010	SS020
1■	9-27	SS110	SS120
2	15-45	SS210	SS220
3	30-90	SS310	SS320
4	45-135	SS410	SS420
5◆	90-270	SS510	SS520

■ Size 00_C, 0, and 1 are supplied without lugs. Lower amperage loads can be protected by looping of power wires.

◆ Size 5 is a complete drop-in replacement for Square D NEMA Type "S" melting alloy, bimetallic, and Y500 overload relays **only**.

Base Unit: Replacement SSOLR for Retrofit of Square D Type S Starter Solid State Overload Relay – 600 Volts AC Maximum

Locate 8536 Starter in this column	NEMA Size	Full Load Current Range (Amperes)	Order Class 9065 Overload from these columns	
			Open Type	
			Trip Class 10	Trip Class 20
SA	00 _C ▼	3-9	SSC10	SSC20
SB	0▼	6-18	SS010	SS020
SC	1▼	9-27	SS110	SS120
SD	2	15-45	SR210	SR220
SE	3	30-90	SR310	SR320
SF	4	45-135	SR410	SR420
SG	5★	90-270	SR510	SR520
SH	6★	180-540	SR610	SR620
SJ	7★	270-810	SR710	SR720

▼ 00_C, 0 and 1 are supplied without lugs. Lug - Extender Kits are available for Size 00_C, 0 and 1.

★ Size 5, 6 and 7 Replacement Overloads are overload relays only for existing NEMA Type "S" starters with Motor Logic. External CTs and additional components are not included.

Additional Standard Features

- Self-powered
- Repeat trip accuracy: +/- 2%
- Normally closed trip contact
- Visible trip indication
- Trip free operation
- Ambient insensitivity
- Harmonic immunity
- Thermal memory
- Trip test function
- 3 Second trip on phase imbalance ≥25% (see Page 13)

Optional Features

- Auxiliary contacts
- Electrical remote reset
- Lug-Lug kits for separate mounting
- DIN rail adapter bracket
- Lug-Extender kit for retrofit (00_C, 0, 1)



Thermal Overload Relays – NEMA Rated Solid State Overload Relay, Motor Logic™ Feature Base Unit

Feature Unit relays include all of the features found on the Base Unit relays plus: switch selectable trip class; Class II ground fault detection; and direct replacement for Type S melting alloy. These relays will also accept the Analog Output Module or Seriplex® communication module. Electrical remote reset is also available.

Feature Unit: For Separate Mounting Solid State Overload Relay 600 Volts AC Maximum

Size (3 Pole)	Full Load Current Range (Amperes)	Open Type
		Trip Class 10/20
00 _B ■	1.5 – 4.5	SFB20
00 _C ■	3 – 9	SFC20
0 ■	6 – 18	SF020
1 ■	9 – 27	SF120
2	15 – 45	SF220
3	30 – 90	SF320
4	45 – 135	SF420
5 ◆	90 – 270	SF520

■ Size 00_B, 00_C, 0, and 1 are supplied without lugs. Lower amperage loads can be protected by looping of power wires.

◆ Size 5 is a complete drop-in replacement for Square D NEMA Type "S" melting alloy, bimetallic, and Y500 overload relays **only**.

Feature Unit: Replacement SSOLR for Retrofit of Square D Type S Starter Solid State Overload Relay – 600 Volts AC Maximum

Locate 8536 Starter in this column	NEMA Size	Full Load Current Range (Amperes)	Order Class 9065 Overload from this column
			Open Type
			Trip Class 10/20
SA	00 _B ▼	1.5 – 4.5	SFB20
SA	00 _C ▼	3 – 9	SFC20
SB	0 ▼	6 – 18	SF020
SC	1 ▼	9 – 27	SF120
SD	2	15 – 45	ST220
SE	3	30 – 90	ST320
SF	4	45 – 135	ST420
SG	5 ★	90 – 270	ST520
SH	6 ★	180 – 540	ST620
SJ	7 ★	270 – 810	ST720

▼ Size 00_B, 00_C, 0, and 1 are supplied without lugs. Lower amperage loads can be protected by looping of power wires.

★ Size 5, 6 and 7 Replacement Overloads are only for existing NEMA Type "S" starters with Motor Logic™. External CTs and additional components are not included.

Additional Standard Features

- Self-powered
- Repeat trip accuracy: +/- 2%
- Normally closed trip contact
- Visible trip indication
- Trip free operation
- Ambient insensitivity
- Harmonic immunity
- Thermal memory
- Trip test function
- Ground fault detection
- 3 Second trip on phase imbalance ≥25% (see Page 13)

Optional Features

- Auxiliary contacts
- Electrical remote reset
- Lug-Lug kits for separate mounting
- DIN rail adapter bracket
- Lug-Extender kit for retrofit (00_B, 00_C, 0, 1)
- 4-20 mADC, analog output module
- Seriplex® communication module



Thermal Overload Relays – NEMA Rated Application Data

General

Overload relays are intended to protect motors, controllers, and branch-circuit conductors against excessive heating due to prolonged motor overcurrents up to and including locked rotor currents. Protection of the motor and the other branch-circuit components from higher currents, due to short circuits or grounds, is a function of the branch-circuit fuses, circuit breakers, or motor short-circuit protectors.

Nameplate Versus NEC Full-load Current

The 1996 NEC in Tables 430-147, 430-148, 430-149 and 430-150 lists full-load currents according to motor horsepower and voltage. According to Article 430-6, these full-load currents should be used, rather than the motor nameplate full-load current, to determine the ampacity of conductors, ampere ratings of switches, or branch-circuit overcurrent devices, etc. It is specifically stated in Article 430-6, however, that “separate motor-running overcurrent (overload) protection shall be based on the motor nameplate current rating.”

Service Factor

NEMA standards for motors list service factors of 1.15 to 1.25 for general-purpose ac motors from 1/2 to 200 horsepower. Other motors, such as totally-enclosed, fan-cooled, and motors over 200 horsepower have a standard 1.0 service factor. Because of the way in which the standards are established, there is no simple way of determining the service factor without looking at the motor nameplate. For this reason all of the thermal unit selection tables in this catalog are designed for 1.15 to 1.25 service factor motors, except the tables for Class 8198 High Voltage Starters. These tables are designed for 1.0 service factor. It is important to know when a motor has a service factor of 1.0, because failure to recognize this fact will result in an over-sized thermal unit selection and reduced motor protection.

Motor Branch Circuit Design

Minimum safety provisions for the control of motors are set forth in the National Electrical Code. Although these minimum provisions **must be met**, they are no substitutes for an intelligent selection of protective devices made on the basis of the motor circuit being designed. The code recognizes this fact in Article 430, Section D, “Where maximum branch-circuit protective device ratings are shown in the manufacturer’s overload relay table for use with a motor controller or are otherwise marked on the equipment, they shall

not be exceeded even if higher values are allowed (by the code).”

Square D furnishes an instruction sheet with every starter. Each instruction sheet includes thermal unit selections and either fuse or circuit breaker selections, or both as applicable.

The capability of industrial systems to deliver high short circuit currents has been increasing steadily over the years. This fact has caused much concern about the capability of motor controllers to withstand high current faults, without creating hazards for personnel and destruction of equipment. NEMA standards require that contactors be able to interrupt currents up to 10 times full load current. Therefore, it is acceptable for the overload relay to respond before the short-circuit protector up to this level. At currents above 10 times motor full load current the short circuit protective device must respond first to minimize equipment damage. A fully coordinated system is achieved when the overload relays operate in response to motor overloads before the fuses or circuit breaker, and the fuses or circuit breaker open the circuit before the overload relays trip or burn out on short-circuit currents.

Proper coordination requires a thorough knowledge of the time versus current limits of all of the branch circuit components as well as the time versus current trip characteristics of the overload relay and short circuit protective device.

Overload Relays

Thermal overload relays sense motor current by converting this current to heat in a resistance element. The heat generated is used to open a normally closed contact in series with a starter coil causing the motor to be disconnected from the line.

In spite of being relatively simple and inexpensive, thermal overload relays are very effective in providing motor running overcurrent protection. This is possible because the most vulnerable part of most motors is the winding insulation and this insulation is very susceptible to damage by excessively high temperature.

Being a thermal model of a motor, the thermal overload relay will produce a shorter trip time at a higher current similar to the way a motor will reach its temperature limit in a shorter time at a higher current. Similarly, in a high ambient temperature, a thermal overload relay will trip at a lower current or vice versa allowing the motor to be used to its maximum capacity in its particular ambient temperature (if the motor and the overload are in the same ambient).



Thermal Overload Relays – NEMA Rated Application Data

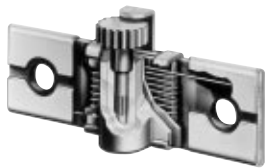

Cutaway View of Standard
Trip Melting Alloy
Thermal Unit



Class 9065 Type SE05
Three-Pole Construction

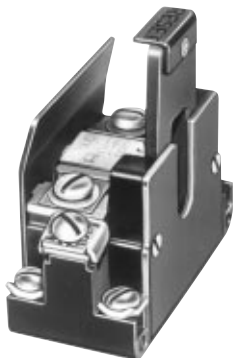

Class 9065 Type CO1
Single Pole Construction

Once tripped, the thermal overload relay will not reset until it has cooled, automatically allowing the motor to cool before it can be re-started.

Square D manufactures two basic types of thermal overload relays, the melting alloy and the bimetallic. In some types, the bimetallic is available in both non-compensated and ambient temperature-compensated versions. In both melting alloy and bimetallic, single element and three element overloads are available.

Motor Logic Solid State overload relays use an electronic method of detection, which responds directly to the motor current. When tripped the overload relay may be reset either manually or remotely using the Remote Reset Module. The Solid State overload relay provides overload protection only for three phase motors rated up to 600 volts AC.

The Solid State overload relay provides protection for phase loss and phase unbalance. In addition, this overload relay is ambient insensitive. The Solid State overload relay is available as a separate trip Class 10 or 20 and as a selectable trip Class 10/20 device.

The Motor Logic solid state overload relay must be selected based on the FLA of the motor it is to protect. Applications involving a motor with an FLA less than 1.5 amps can be addressed by passing multiple looped turns of the motor leads through the current transformer windows.

Hand Reset Melting Alloy

Application

Hand reset melting alloy overload relays use a eutectic alloy solder which responds to the heat produced in a heater element by the motor current. When tripped, the overload relay may be reset manually after allowing a few minutes for the motor and relay to cool and the solder to solidify.

Square D's one-piece thermal unit construction will provide overload protection for the majority of motors. Repeated tripping does not affect the original calibration. Melting alloy thermal units are available in three designs: standard trip, slow trip and quick trip.

Standard Trip (Class 20)—All standard trip thermal units provide trip characteristics for normal motor acceleration up to approximately 7 seconds on a full voltage start.

Slow Trip (Class 30) – Type SB thermal units provide trip characteristics for motor acceleration up to approximately 12 seconds on a full voltage start. The motor should be suitable for extended starting periods.

Quick Trip (Class 10) – Type FB thermal units are used to protect hermetically sealed, submersible pump and other motors which can endure locked rotor current for a very short time, or motors which have a low ratio of locked rotor to full load current.

Replaceable Contacts – The contact modules of Type S, F and G overload relays are replaceable. Refer to Page 13.

Alarm Contacts – Contact modules with one N.O. and one N.C. contact are available for Type S, F, and G overload relays. For Type S, specify Form Y34-2; for Types F and G, specify Form Y34. Y34-2 indicates a four terminal isolated contact module and Y34 indicates a three terminal module with a common terminal between the N.O. and N.C. contacts. Refer to Page 13.

Contact Ratings – For the overload relay control circuit contact ratings refer to Page 13.



Thermal Overload Relays – NEMA Rated Application Data

Power Circuit Voltage Ratings

Type	AC — 50 or 60 Hz	DC
C, F, G, T, U	600	600
A, S	600	—
AF, AG, AR, AT, AU	600	600

AC — 50 or 60 Hz							DC					
Type	NEMA Contact Ratings	Volts (Minimum of 110 volts is recommended)	Inductive 35% Power Factor				Type	Form	Volts	Inductive and Resistive		
			Make		Break						Make and Break Amperes	
			Amps	VA	Amps	VA						
AD, AG, AR, AT, AU, C, F, G, T, U, SAF, SAG, SAU, SDO18 SS, SSF, SR, ST	A600	120	60	7200	6	720	AF, AG, AR, AT, AU, SAF, SAG, SAU	Std.	125	.55		
		240	30	7200	3	720						
		480	15	7200	1.5	720	C, T, U	Std., Y34, or Y342	125 250	1.1 .55		
		600	12	7200	1.2	720						
SD & SE (Sizes 0-4 & 6), Class 9998 Type SO1 and Class 9999 Type SO4 and SO5 Contact Modules	B600	120	30		3	360	F GO11 SDO18	Std.	125 250	.55 .27		
		240	15	3600	1.5	360						
		480	7.5	3600	.75	360	SD & SE (Sizes 0-4 & 6)	Std.	—	—		
		600	6.0	3600	.6	360						
									SD & SE (Sizes 0-4 & 6)	Y34 or Y342	125	.22
							Class 9999 Type SO4 and SO5	Std.				
							SS, SF, SR, ST	Std.	125 250	1.1 .55		

Accessories

Isolated Auxiliary Contacts for Motor Logic Overload Relays

Overload Relay auxiliary contacts are available factory installed or in kit form for field installation on Motor Logic Overload Relays. These contacts may be used for isolated alarm contact applications.

For Use with		Description	Class 9999 Parts Kit
Type	NEMA Size		
8536 SA-SJ	00 _B through 7	N.O. or N.C. Auxiliary Contact (Field Convertible)	AC04
9065 SS, SR, SF, ST	00 _B through 7		

DIN Adapter

The DIN adapter provides a method to mount the Motor Logic overload relay to a 35 mm DIN rail.

For Use With		Description	Class 9999 Parts Kit
Type	NEMA Size		
9065 SS or SF	00 _B , 00 _C , 0, and 1	DIN Adapter	DA01

Lug-Lug/Lug-Extender Kits

A Class 9999 LL0 Lug-Lug Kit can be field installed on separately mounted overload relays. The standard NEMA Size 00_B, 00_C, 0, and 1 Class 9065 Type SS and SF Overload Relays are supplied without lugs. A Class 9999 LB0 Lug-Extender Kit is designed for NEMA Size 00_B, 00_C, 0, and 1 Retrofit Starter Applications. This kit allows the lugs to be in the same location as the Class 9065 Melting Alloy Overload Relay, eliminating the need for additional wire length.

For Use With		Description	Class 9999 Parts Kit
Type	NEMA Size		
9065 SS or SF	00 _B , 00 _C , 0, and 1	Lug-Lug Kit for separate mounting	9999 LL0
9065 SS or SF	00 _B , 00 _C , 0, and 1	Lug-Extender Kit for retrofitting existing NEMA Type "S" starters	9999 LB0



Thermal Overload Relays – NEMA Rated

Application Data

Remote Reset Module

The Remote Reset Module can be easily field installed on solid state overload relays. This module will allow the overload relay to be reset from a remote location.

For Use With		Description	Class 9999 Parts Kit
Type	NEMA Size		
8536 SA-SJ	00 _B through 7	Remote Reset Module	RR04●
9065 SS, SR, SF, ST	00 _B through 7		
8536 SE-SF	3 and 4	Top Mounting Bracket	RB34▲●
9065 SS, SR, SF, ST	3 and 4		

- ▲ To be used to mount the remote reset module on the top of the overload relay.
- 120Vac power required.

4 – 20 ma DC Communication Module

This module provides 4 - 20 mADC output proportional to the percentage of current flowing to the motor, according to the trip current adjustment setting. This feature works only on 9065 SF and ST overload relays.

For Use With		Voltage	Description	Class 9999 Parts Kit
Type	NEMA Size			
9065 SF, ST	00 _B through 7	120Vac	4-20 mADC Output	AO01
9065 SF, ST	0 through 4	24Vdc	4-20 mADC Output	AO02

Contact Units for Melting Alloy Type Overload Relays

One normally closed contact, Class 9998 Type SO1, is provided in each overload relay block on Type S starters Sizes 00-4 and Size 6. On the Type S Size 5, a normally closed contact is provided with each of the three overload relay blocks. The Class 9998 Type SO1 contact unit listed below is provided as standard in each Class 9065 Type M melting alloy overload relay. Contact modules can be easily replaced and are identified in the table below. Isolated overload relay alarm circuit contacts are available as an optional feature. A pilot light or alarm bell can be wired in series with this contact to indicate that the overload relay has tripped. For further information on isolated alarm contacts refer to Class 9999 Types SO4 and SO5.

Magnetic Starter			Description▲	Parts Kit Number
NEMA Size	Type	Series		
00-4 & 6	SA-SF SH	A & B	Standard N.C. contact unit	Class 9998 Type SO1‡
5	SG	A	Standard N.C. contact unit	31102-514-50
			N.C. and N.O. alarm (three point) contact unit	31102-514-51

▲ Refer to Page 11-131 for contact ratings.

‡ The Type SO1 is also the replacement contact unit for Class 9065 Type M melting alloy overload relays.

Melting Alloy Overload Relay Jumper Strap Kits

Jumper strap kits are for use on three-phase manual or magnetic starters with melting alloy overload relays only, where a three-phase starter is used to control a single-phase motor. These kits will include two jumper straps, a wiring diagram showing how to wire a three-phase starter to control a single-phase motor, and single-phase (one thermal unit) selection tables.

Class	For Starter		Class 9998 Kit Type No.
	Size	Type	
ALL	00, 0, 1, 2 and M0 & M1	SA, SB, SC, SD and M & T (Manual)	SO31
	3,4	SE, SF	SO32
	5	SG	None Available

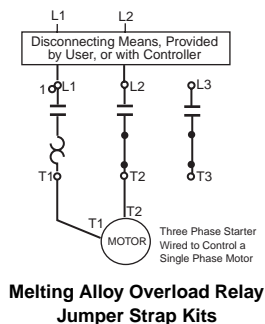

Thermal Overload Relays – NEMA Rated Approximate Dimensions

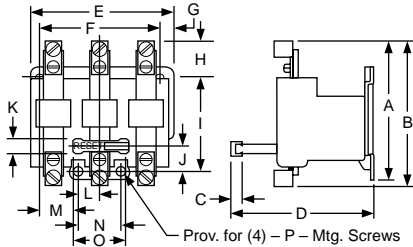

Type SEO

Melting Alloy Type NEMA Style

Type	Dimensions																Shipping Weight (Lbs)
	A	B	C	D	E	F	G	H	I	J	K	L	M	N	O	P	
SEO5	3 ⁹ / ₁₆	—	1 ⁵ / ₃₂	3 ³¹ / ₃₂	3 ¹⁷ / ₃₂	2 ¹³ / ₁₆	7 ₃₂	1 ¹ / ₁₆	2 ⁵ / ₁₆	1 ₂	1 ₂	1 ₂	2 ⁷ / ₃₂	1	1 ³ / ₈	#10	1
SEO8	3 ⁹ / ₁₆	—	1 ⁵ / ₃₂	3 ³¹ / ₃₂	3 ¹ / ₂	2 ¹³ / ₁₆	3 ₁₆	1 ¹ / ₁₆	2 ⁵ / ₁₆	1 ₂	1 ₂	1 ₂	2 ⁷ / ₃₂	1	1 ³ / ₈	#10	1 ¹ / ₄
SEO12	—	5 ¹⁹ / ₃₂	9 ₁₆	5 ³ / ₄	5 ⁵ / ₁₆	4 ³ / ₄	9 ₃₂	1 ⁷ / ₁₆	3 ⁹ / ₁₆	3 ₄	9 ₁₆	7 ₈	1 ¹ / ₂	1 ³ / ₄	2	#1 ₄	3
SEO15	—	6 ³¹ / ₃₂	9 ₁₆	5 ³ / ₄	5 ⁵ / ₁₆	4 ³ / ₄	9 ₃₂	2 ¹ / ₈	3 ⁹ / ₁₆	3 ₄	9 ₁₆	7 ₈	1 ¹ / ₂	1 ³ / ₄	2	#1 ₄	4

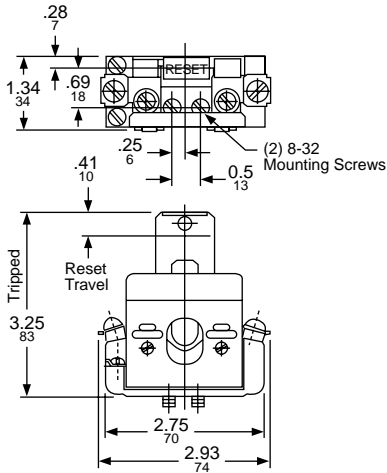

Type CO1
Weight - 1/2 Lb

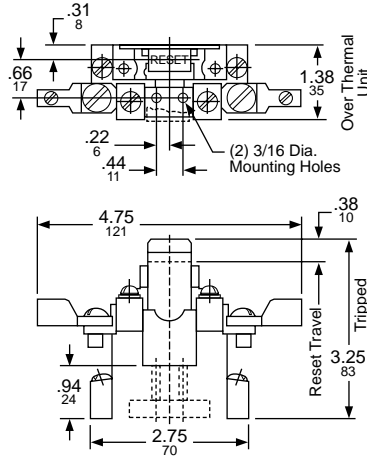

Type TO1 *
Weight - 1/2 Lb

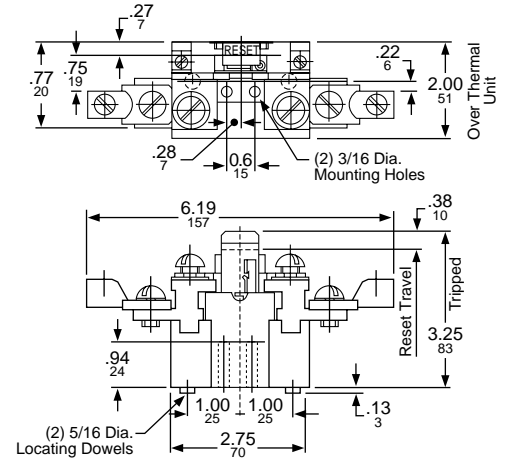

Type UO1 *
Weight - 1 1/2 Lb

* Dimensions shown for Types TO1 and UO1 do not apply when Form Y342 or Y34 is supplied.

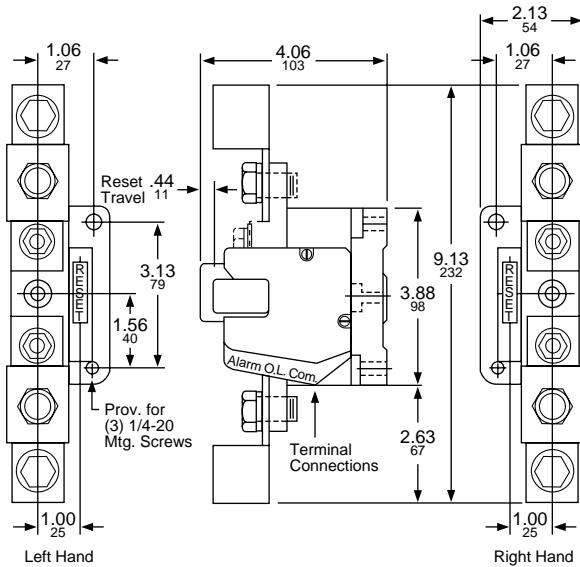

Types GO11L and GO11R
Weight - 5 Lbs

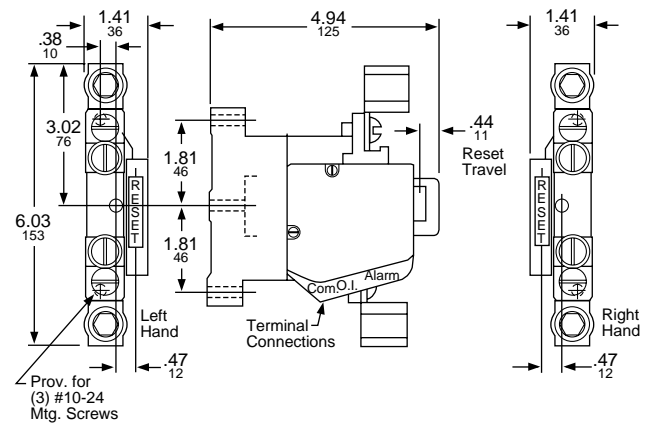

Types FO1L and FO1R
Weight - 2 Lbs

Dual Dimensions: INCHES
Millimeters



Thermal Overload Relays – NEMA Rated

Approximate Dimensions

Bimetallic Overload Relays

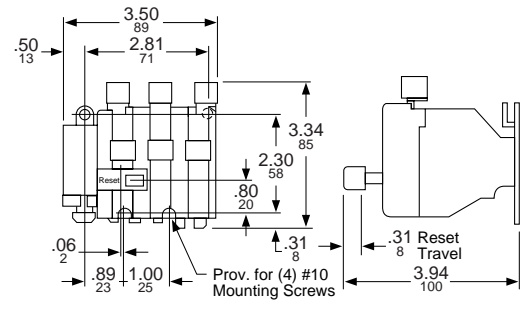
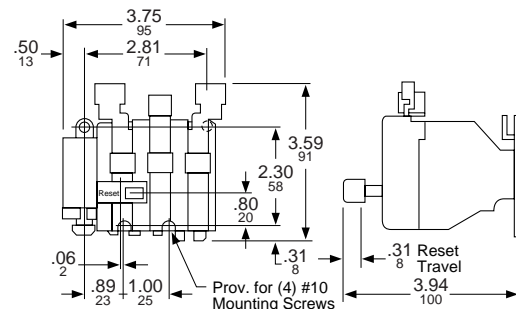

Types SEO6B and SEO6B2

Weight — 1 Lb

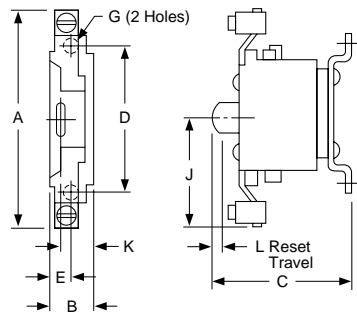

Types SEO9B and SEO9B2

Weight — 1 1/4 Lb

Class 9065	Amp Rating	Outline Dimensions			Mounting Dimensions		Reset Dimensions		Mounting Screw	Maximum Wire Size	Approx. Shipping Weight (Lbs)
		A	B	C	D	E	K	L			
DA	25	3 1/2	7/8	3 3/16	3	1/2	3/8	1/8	10	8	2
GA	60	4 7/8	7/8	3 3/16	3	1/2	3/8	1/8	10	1	2
HA	100	4 7/8	1 1/4	3 3/16	3 1/2	1/16	1/2	1/8	10	00	3
JA	180	5 15/16	1 1/4	3 3/16	3 1/2	1/2	3/16	1/8	10	250 MCM	4

All dimensions shown in inches.



Thermal Overload Relays – NEMA Rated Approximate Dimensions

Motor Logic™ – Solid State Overload Relay

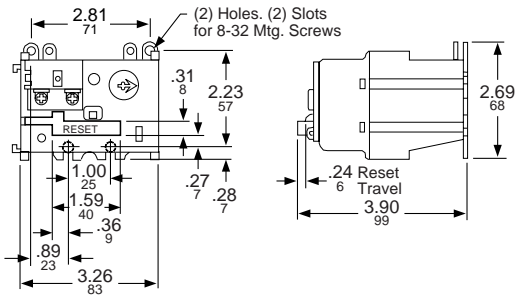

NEMA Size 00_B, 00_C, 0, and 1 Devices

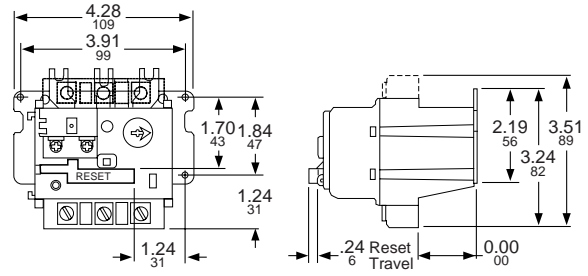

NEMA Size 2 Devices

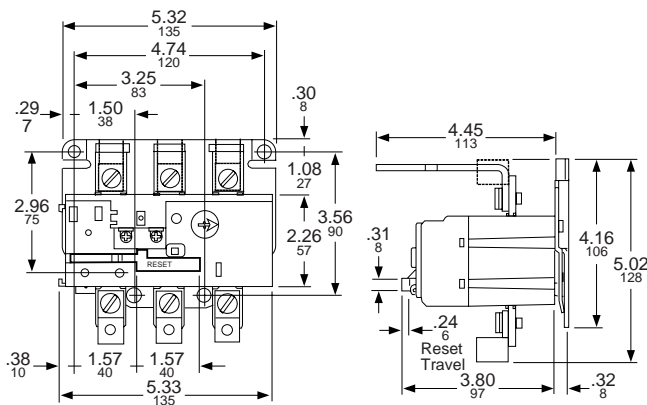

NEMA Size 3 Devices

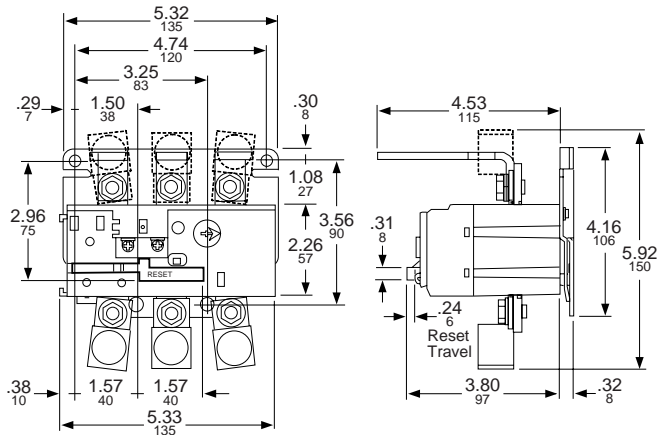

NEMA Size 4 Devices

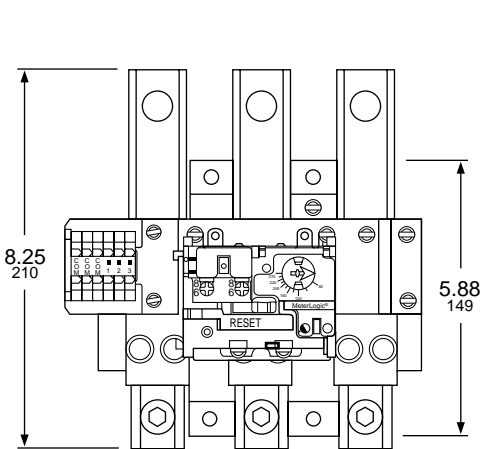

NEMA Size 5 Device

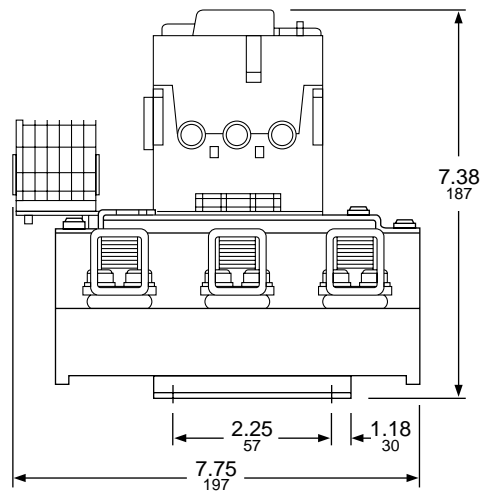

Note that the dimensions are for reference only; it is designed exclusively for NEMA Type "S" Size 5 starters and only for melting alloy, bimetallic, and Y500 overload relay assemblies.



Overload Relay Comparison

OVERLOAD RELAY COMPARISON

Information is subject to change without notice.

Overload Relay	Type	Trip Indication	Reset Mechanism	Solid State Overload
Allen Bradley Bulletin 592/593 Series	Melting Alloy Bulletin 592	Yes, an optical indicator which turns yellow.	Manual Only	<ul style="list-style-type: none"> • Self Powered SMP1, SMP2 only • External Power SMP3 • Phase Loss SMP1, SMP2, SMP3 • Grd. Fault and Jam Prot. SMP2, SMP3 only • Selectable Trip Classes SMP2, SMP3 only 10, 15, 20, 30 • Com. Capabilities SMP3 only • Led Indication SMP3 only
	Bimetallic Bulletin 593	Yes, an optical indicator which turns yellow.	Automatic	
	Solid State Bulletin 592 SMP1, SMP2, SMP3	Yes, yellow trip flag appears in window.	SMP1 Manual only or selectable (Man/Auto) SMP2, SMP3 selectable (Man/Auto)	
Cutler Hammer Freedom Series	Melting Alloy	Yes, orange trip flag appears in window.	Selectable (Man/Auto)	N/A
	Bimetallic	Yes, orange trip flag appears in window.	Selectable (Man/Auto)	
Furnas Innova® Plus/ESP 100®	Melting Alloy	No	Manual (must push to reset)	<ul style="list-style-type: none"> • Self Powered ESP 100 • Phase Loss • Separate Trip Classes 10, 20, 30
	Bimetallic	No	Manual (must push to reset)	
	Solid State	Yes, reset button moves (not noticeable).	Manual (must push to reset)	
General Electric Line 300 Series	Melting Alloy	Yes, yellow trip flag appears in window.	Manual only, optional Reset Module	<ul style="list-style-type: none"> • Self Powered • Phase Loss • Phase Unbalance (adjustable) • Selectable Trip Classes 10, 20, 30
	Bimetallic	Yes, yellow trip flag appears in window.	Manual only, optional Reset Module	
	Solid State	Yes, yellow trip flag appears in window.	Manual only, optional Reset Module	
Westinghouse Advantage®	Solid State	No, optional light accessory.	Convertible (Man/Auto) through dip switches. Remote Reset module available	<ul style="list-style-type: none"> • 120 V control power • Phase Loss • Phase Unbalance • Dip Switch setting 10, 20, 30 or none • Grd. Fault Protection
Square D Type S	Melting Alloy	Yes, yellow trip flag	Manual Only	<ul style="list-style-type: none"> • Self Powered • Base and Feature Base • Phase Loss • Phase Unbalance • Grd. Fault Detection Feature Base only • Selectable Trip Classes Feature Base, 10 or 20 • Com. Capabilities Feature Base only • 4-20 Comm. Module Feature Base only • Harmonic Immune • Power LED Indication • Ambient Insensitive
	Bimetallic	Yes, yellow trip flag appears in window.	Selectable or Manual	
	Solid State	Yes, yellow trip flag appears in window.	Manual Only, Remote Reset module available	



General

All tables are based on the operation of the motor and controller in the same ambient temperature, 40°C (104°F) or less. Always be certain the correct thermal units are installed in the starter before operating the motor. Each thermal unit shall be installed such that its catalog number is visible. On melting alloy thermal units the ratchet wheel must engage the pawl assembly.

Selection Procedure

1. Determine motor data:
 - a. Full load current rating
 - b. Service factor

NOTE: If motor full load current is not known, a tentative thermal unit selection could be made, based on horsepower and voltage. Refer to Page 22.

2. Motor and controller in *same ambient temperature*:
 - a. All starter classes, except Class 8198:
 1. For 1.15 to 1.25 service factor motors use 100% of motor full load current for thermal unit selection.
 2. For 1.0 service factor motors use 90% of motor full load current for thermal unit selection.
 - b. Class 8198 only:
 1. For 1.0 service factor motors use 100% of motor full load current for thermal unit selection.
 2. For 1.15 to 1.25 service factor motors use 110% of motor full load current for thermal unit selection.
3. Motor and controller in *different ambient temperatures*:
 - a. Multiply motor full load current by the multiplier in Table A. Use the resultant full load current for thermal unit selection.

4. Locate proper selection table from index, Pages 19 and 20.
 - a. The proper thermal unit number will be found adjacent, to the right of the range of full load currents in which the motor full load current or resultant full load current falls.

5. See Page 21 for calculation of trip current rating.

Slow Trip Thermal Unit Selection

To select Type SB slow trip thermal units, the selection table for a standard Type B thermal unit may be used with the following modifications: For continuous rated motors having service factors of 1.15 to 1.25, select thermal units from the

standard Type B table using 93% (102% for Class 8198) of the full load current shown on the motor nameplate and then substitute an SB for the B in the thermal unit type number.

Example: A motor with a full load current of 14 amps controlled by an 8536 SCG3 would require B22 thermal units for standard trip applications and SB19.5 thermal units for slow trip applications. The SB is selected by multiplying 14 amps times 93% for 13.02 amps and using this value to select B19.5s. Then add the S prefix to arrive at SB19.5s.

For continuous rated motors having a service factor of 1.0, select thermal units in the same manner using 84% (93% for Class 8198) of full load current shown on the motor nameplate.

NOTE: SB thermal units are used on Size 0, 1, 2 and only some Size 3 applications. Check thermal unit tables for current ranges.

Table A: Selection of Thermal Units for Special Applications

Class of Controller	Continuous Duty Motor Service Factor	Melting Alloy and Non-Compensated Bimetallic Relays		Ambient Temp.-Comp. Relays	
		Ambient Temperature of Motor			
		Same as Controller Ambient	Constant 10° C (18° F) Higher Than Controller Ambient	Constant 10° C (18° F) Lower Than Controller Ambient	Constant 40° C (104° F) or Less, for Any Controller Ambient
		Full Load Current Multiplier			
All Classes, Except 8198	1.15 to 1.25	1.0	0.9	1.05	1.0
	1.0	0.9	0.8	.95	0.9
Class 8198	1.15 to 1.25	1.1	1.0	1.15	1.1
	1.0	1.0	0.9	1.05	1.0

Thermal Units

Melting Alloy		Bimetallic	
Type of Trip	Thermal Unit Type	Type of Trip	Thermal Unit Type
Standard	A	Standard	AR
	B		AF
	C		AU
	CC		E
	DD		
Quick	FB		
Slow	SB		



Thermal Unit Selection

Quick Trip Thermal Unit Selection

To select Type FB quick blow trip thermal units, the selection table for a standard Type B thermal unit may be used with the following modifications: for continuous rated motors having service factors of 1.15 to 1.25, select thermal units from the standard Type B table using 93% (102% for Class 8198) of the full load current shown on the motor nameplate and then substitute a FB for the B in the thermal unit type number.

Example: A motor with a full load current of 14 amps controlled by an 8536 SCG3 would require B22 thermal units for a standard trip application and FB19.5 thermal units for quick trip applications. The FB is selected by multiplying 14 amps times 93% for 13.02 amps and using this value to select B19.5. Then add the F prefix to arrive at FB19.5.

For continuous rated motors having a service factor of 1.0, select thermal units in the same manner using 84% (93% for Class 8198) of full load current shown on the motor nameplate.



Thermal Unit Selection

Controller					Thermal Unit Selection Table Number				
					Hand Reset Melting Alloy			Bimetallic	
Starter Type	Class	Type	*Series	Size	Standard Trip (20)	Quick Trip (10)	Slow Trip (30)	Non-Compensated	Compensated
Manual Starters FHP	2510 2512 8908	F	A	FHP	43★
Manual Starters (Small Enclosure)	2510	M, T	A	M-0 M-1 M-1P	1 1 1	72 72 72	X X X
Manual Starters (Large Enclosure)	2510 2511 2512 8925	M, T	A	M-0 M-1 M-1P	2 2 2	73 73 73	X X X
Manual Starter w/LVP (Small Enclosure)	2510	M, T	A	M-0 M-1 M-1P	3 3 3	X X X
Manual Starter w/LVP (Large Enclosure)	2510 2511 2512 8908	M, T	A	M-0 M-1 M-1P	4 4 4	X X X
Manual Loom Sw.	2510	MBL, TBL	A	M-0	7	X
DC Magnetic Starters	7135	C, D	1,2	65	X
	7136	E	3	9
	7735	F	4	10
	7736	G	5	12
AC Magnetic Starters (Small Enclosure)	8536 8904♦ (Starter In Own Enclosure)	A (8536 only)	B, C	00	17★
		SA	A, B	00	13	X
		SB	A	0	13	74	X	8	33
		SC	A	1	13	74	X	8	33
			A	1P	41	X
		SD	A	2	56	75	X	62	70
		SE	A	3	18	76◊	134◊X	63	37‡
			B	3	142
		SF	A	4	54	77◊	11	29‡
			B	4	144
	SG	A	5	49◻	38	46	
	SH	A	6	21	39	47	
	8998 8999 (Model 3 Control Center) I-LINE® and QMB Motor Starter Centers	SC	A	1 Fusible	66	74	64	33
			A	1 Circuit Breaker	15	74
		SD	A	2 Fusible	67	75	57	70
			A	2 Circuit Breaker	58†	75
		SE	A	3 Small Enclosure	16	76◊	134◊X	51	37‡
			A	3 Large Enclosure	68†	76◊	133◊X
		B	3	141
		
		SF	A	4	61	77◊	35	29†
			B	4	143
	SG	A	5	24	52	46	
	SH	A	6	20	48	47	
	8998 (Model 5 Control Center)	SC#	A	1 Fusible	109	97
			A	1 Circuit Breaker	115	103
		SD#	A	2 Fusible	110	98
			A	2 Circuit Breaker	116	104
SE#		A	3 Fusible	111	99	
		A	3 Circuit Breaker	117	105	
SF#		A	4 Fusible	112	100	
		A	4 Circuit Breaker	118	106	
SG#		A	5 Fusible	113	101	
		A	5 Circuit Breaker	119	107	
SH#	A	6 Fusible	114	102		
	A	6 Circuit Breaker	120	108		
8911	DPSG	A	20-30A	135	
			40A	145	
			50A	146	

Table continued on the next page; see Page 20 For Footnotes.

NOTE: For thermal unit selection tables for other devices including obsolete devices, consult local Square D field office.



Thermal Unit Selection

Controller					Thermal Unit Selection Table Number						
					Hand Reset Melting Alloy			Bimetallic			
Starter Type	Class	Type	*Series	Size	Standard Trip	Quick Trip (10)	Slow Trip (30)	Non-Compensated	Compensated		
AC Magnetic Starters (Large Enclosure)	8198	G, S	5	X	6		
	8536 (Starter Used in Multi-Motor Panel)	A (8536 only)	B, C	00	14★		
	8538 8904■	SA	A, B	00	53	X	55	25		
	8539 8906	SB	A	0	15	78	X	64	33		
	8606 8907	SC	A	1	15	78	X	64	33		
	8630● 8920	SD	A	2	58	79	X	57	70		
	8640▲ 8922	SE	A	3	16	80◇	133◇X	51	37‡		
	9089 8924		B	3	141		
	8647 8925	SF	A	4	61	81◇	35	29‡		
	8650 8930		B	4	143		
	8736 8941	SG	A	5	24‡	52	46		
	8738	8810 8811 8812	CB, DB, SB, UB	A	0	15	78	X	64	33	
	8739			CC, DC, SC, UC	A	1	15	78	X	64	33
				CD, DD, SD, UD	A	2	58	79	X	57	70
				CE, DE, SE, UE	A	3	16	80◇	133◇X	51	37‡
			CF, DF, SF, UF	A	4	61	81◇	35	29‡	
			SE	B	3	141	
			SF	B	4	143	
			CG, DG, SG, UG	A	5	24‡	52	46	
			CH, DH, SH, UH	A	6	20	X	48	47	
			8940 WELL-GUARD® Control	WC, XC	A	1	78	33
		WD, XD, MD, RD, VD		A	2	79	70	
		WE, XE, ME, RE, VE		A	3	80◇	37‡	
		PF, WF, XF, MF, RF, VF		A	4	81◇	29‡	
		XSG, NSG, MG, RG, VG★		A	5	46	
		XSH, VH		A	6	47	
		8911	DPSO	A	20-30A	136	
					40A	147
					50A	148
	AC Magnetic Part- Winding	8998 8999 (Model 5 MCC)	SC#	A	1 Fusible	127	121	
					1 Circuit Breaker	130	124	
			SD#	A	2 Fusible	128	122	
					2 Circuit Breaker	131	125	
			SE#	A	3 Fusible	129	123	
					3 Circuit Breaker	132	126	
	Separately Mounted Overload Relays	9065	AF	B	4(133A)	30	
			AG	A	5(266A)	36	
			AR	A	1(25A)	32	
AT			A	2(45A)	60		
AU			3(86A)	50		
DA			A	1(25a)	140‡		
GA			A	2(60A)	139‡		
HA			A	3(100A)	138‡		
JA			A	4(180A)	137‡		
C			A	1(25A)	44	82	X		
F			B	4(133A)	19	85◇		
G			A	5(266A)	22		
MEO			A	(32A)	86		
S			A	1(26A)	59	83	X	23	42		
			A	2(45A)	69	84	X	27	71		
			A	3(86A)	34		
			A	4(133A)	28		
T			A	2(45A)	31	X		
U	3(86A)	40				

* Series letters listed refer to the marking on the nameplate of the basic open type starter. When the starter is supplied in a controller containing other devices, the controller may have a different series letter marked on the enclosure nameplate.

◆ Small enclosure tables apply for **Class 8904** non-combination and non-reversing starters. For combination and reversing **Class 8904** starters refer to the large enclosure selections, index above.

● For **Class 8630** starters divide the delta connected motor full load current by 1.73, and use this quotient to select thermal units.

▲ For **Class 8640** starters use the full load current of each motor winding as a basis for thermal unit selection - normally one-half total motor current.

■ Large enclosure tables apply for **Class 8904** combination and reversing starters. For non-combination and non-reversing **Class 8904** starters refer to small enclosure selections.

† Use for Autotransformer Starters (Fusible and Circuit Breaker).

‡ Order Type E thermal units by number from Square D Company.

★ Type A thermal units for full load currents lower than those listed in this table are available. For complete information, consult local Square D field office.

◇ Form Y81 must be specified to use quick trip (Class 10) or slow trip (Class 30) thermal units on Size 3 starters and quick trip (Class 10) thermal units on Size 4 starters.

X This device will accept Type SB slow trip (Class 30) thermal units. For selection, see Page 18.

Refers to type number of starter in MCC, not actual type number of MCC.

‡ For Y500 Device select Table 151, which uses "B" Thermal Units.



CALCULATION OF TRIP CURRENT RATING

Trip Current Rating – Trip current rating is a nominal value which approximates the minimum current to trip an overload relay in an ambient temperature, outside of the enclosure, of 40°C (104°F). In all selection tables, except Class 8198 the trip current rating is 1.25 times the minimum full load current shown for the thermal unit selected. For Class 8198, the trip current rating is 1.15 times the minimum full load current. This applies to bimetallic overload relays with the trip adjustment set at 100 percent.

Calculation Procedure

1. Use the selection table for the specific controller involved.
2. Find the minimum motor full load current listed for the thermal unit in question.
3. Multiply that current by 1.25 (1.15 for Class 8198). The result is the trip current rating.

Example 1: Determine the thermal unit selection and trip current rating for thermal units in a Class 8536 Type SCG3 Size 1 magnetic starter used to control a three-phase, 1.15 service factor motor with a full load current of 17.0 Amperes, where the motor and controller are both located in a 40°C (104°F) ambient temperature.

1. From Table 13 the proper selection is B32.
2. The minimum motor full load current is 16.0 Amperes.
3. Trip current rating is 16.0 x 1.25= 20.0 Amperes.

Protection Level is the relationship between trip current rating and full load current. Protection level, in percent, is the trip current rating divided by the motor full load current times 100. In Example 1 the protection level for the B32 thermal unit is: 20.0/17.0 x 100=118%.

National Electrical Code, Section 430-32, allows a maximum protection level of 125% for the motor in the above example.

Minimum Trip Current (also called ultimate current) may vary from the trip current rating value, since ratings are established under standardized test conditions. Factors which influence variations include: the number of thermal units installed, enclosure size, proximity to heat producing devices, size of conductors installed, ambient (room) temperature, and others.

Except for ambient temperature-compensated overload relays, an ambient temperature higher than 40°C would lower the trip current, and a lower temperature would increase it. This variation is not a factor in selecting thermal units for the average application, since most motor ratings are based on an ambient temperature of 40°C, and motor capacity varies with temperature in about the same proportion as the change in trip current. Temperature-compensated relays maintain a nearly constant trip current over a wide range of ambient temperature, and are intended for use where the relay, because of its location, cannot sense changes in the motor ambient temperature.

CALCULATION OF TRIP CURRENT FOR AMBIENT TEMPERATURES OTHER THAN 40°C

For a controller ambient temperature other than 40°C (104°F) trip current can be calculated by applying a correction factor from the curve in Figure 1. The approximate trip current for a particular ambient temperature is the product of (1) the multiplier M corresponding to the temperature and (2) the 40°C trip current rating.

NOTE: Ambient temperature is the temperature surrounding the starter enclosure. Normal temperature rise inside the enclosure has been taken into account in preparing the thermal unit selection tables.

Example 2: Determine the trip current for the motor and controller in Example 1, except the controller is in a 30°C (86°F) ambient temperature. From the curve in Figure 1 the multiplier M is 1.1 at 30°C. Approximate Trip Current is 16.0 x 1.25 x 1.1=22 Amperes.

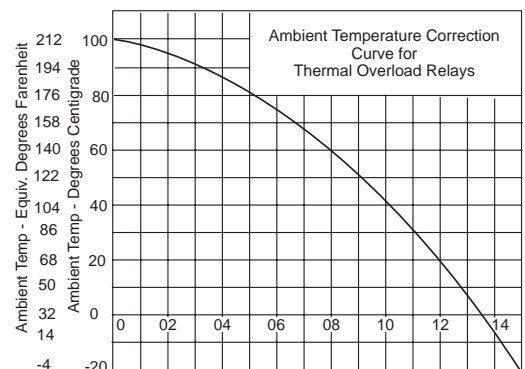

Thermal Unit Selection

APPROXIMATE THERMAL UNIT SELECTION BASED ON HORSEPOWER AND VOLTAGE

General

Thermal units selected using approximate full load currents from the table below will provide a trip current between 101% and 125% of full load current for many 4-pole, single speed, normal torque, 60 Hz motors. Since full load current rating of different makes and types of motors vary so widely, these selections may not be suitable.

Thermal units should be selected on the basis of motor nameplate full load current and service factor. Thermal unit sizes originally selected on an approximate basis should always be rechecked and corrected at the time of installation if required.

Instructions

1. Locate motor horsepower and voltage.
2. Determine approximate full load current from the table below.
3. Use approximate full load current in place of actual nameplate full load current and follow instructions on Page 18.

Only Use This Table When Motor Full Load Current Is Not Known

Motor Horsepower	Motor Full Load Current					
	Three PH				Single PH	
	200 V	230 V	460 V	575 V	115 V	230 V
1/20	0.39	0.34	0.17	0.14	1.30	0.65
1/12	0.55	0.48	0.24	0.19	1.90	0.95
1/8	0.74	0.64	0.32	0.26	2.60	1.30
1/6	0.90	0.78	0.39	0.31	3.24	1.62
1/4	1.22	1.06	0.53	0.42	4.40	2.20
1/3	1.52	1.32	0.66	0.53	5.47	2.74
1/2	2.07	1.80	0.90	0.72	7.45	3.73
3/4	2.88	2.50	1.25	1.00	10.1	5.07
1	3.68	3.20	1.60	1.28	12.6	6.31
1 1/2	5.18	4.50	2.25	1.80	17.2	8.59
2	6.67	5.80	2.90	2.32	21.4	10.7
3	9.66	8.40	4.20	3.36	29.1	14.5
5	15.4	13.4	6.68	5.35	42.9	21.4
7 1/2	22.6	19.6	9.82	7.86	58	29.2
10	29.7	25.8	12.9	10.3	—	36.3
15	43.6	38.0	19.0	15.2	—	49.9
20	57.4	49.9	24.9	20.0	—	—
25	70.9	61.7	30.8	24.7	—	—
30	84.3	73.3	36.7	29.3	—	—
40	111.	96.4	48.2	38.5	—	—
50	137.	119.	59.6	47.6	—	—
60	163.	142.	70.8	56.6	—	—
75	201.	175.	87.6	70.0	—	—
100	265.	230.	115.	92.0	—	—
125	327.	284.	142.	114.	—	—
150	389.	338.	169.	135.	—	—
200	511.	445.	222.	178.	—	—

NOTE: These currents should not be used for selection of fuses, circuit breakers or wire sizes. See NEC tables 430-148 through 430-150. For motors rated 208-220 volts, use 230 V column. For motors rated 440 to 550 volts, use 460 and 575 V columns, respectively.



Figure 1

Mounting Thermal Units

Always be certain the correct thermal units are installed in the starter before operating the motor. Thermal units should always be mounted so that their type designation can be read from the front of the starter (see Figure 1). Melting alloy thermal units should be mounted so that the tooth of the pawl assembly can engage the teeth of the ratchet wheel when the reset button is pushed.

Mounting surfaces of starter and thermal units should be clean and care should be taken to insure that thermal unit mounting screws are fastened securely.



Thermal Unit Selection Tables 1 thru 6

Table 1

Motor Full-Load Current (Amp)		Thermal Unit Number
1 T.U.	3 T.U.	
0.33-0.36	0.29-0.32	B 0.44
0.37-0.40	0.33-0.36	B 0.51
0.41-0.45	0.37-0.39	B 0.57
0.46-0.52	0.40-0.47	B 0.63
0.53-0.59	0.48-0.56	B 0.71
0.60-0.66	0.57-0.63	B 0.81
0.67-0.73	0.64-0.69	B 0.92
0.74-0.81	0.70-0.77	B 1.03
0.82-0.91	0.78-0.86	B 1.16
0.92-1.02	0.87-0.96	B 1.30
1.03-1.14	0.97-1.11	B 1.45
1.15-1.29	1.12-1.23	B 1.67
1.20-1.42	1.24-1.37	B 1.88
1.43-1.64	1.38-1.55	B 2.10
1.65-1.80	1.56-1.75	B 2.40
1.81-2.10	1.76-1.92	B 2.65
2.11-3.20	1.93-2.16	B 3.00
2.31-2.61	2.17-2.50	B 3.30
2.62-2.99	2.51-2.81	B 3.70
3.00-3.37	2.82-3.16	B 4.15
3.38-3.94	3.17-3.40	B 4.85
3.95-4.24	3.41-3.76	B 5.50
4.25-4.54	3.77-4.00	B 6.25
4.55-5.29	4.01-4.68	B 6.90
5.30-5.73	4.69-5.18	B 7.70
5.74-6.35	5.19-5.51	B 8.20
6.36-7.08	5.52-6.19	B 9.10
7.09-7.83	6.20-7.12	B 10.2
7.84-8.47	7.13-8.15	B 11.5
8.48-9.83	8.16-8.60	B 12.8
9.84-10.5	8.61-9.21	B 14
10.6-11.4	9.22-10.1	B 15.5
11.5-12.8	10.2-11.2	B 17.5
12.9-13.9	11.3-12.0	B 19.5
14.0-16.1	B 22
16.2-18.0	B 25
Following Selections for Size M-1 & M-1P Only.		
.....	11.3-12.1	B 19.5
.....	12.2-13.6	B 22
16.2-17.6	13.7-15.3	B 25
17.7-20.6	15.4-17.3	B 28.0
20.7-23.1	17.4-19.1	B 32
23.2-26.0	19.2-21.7	B 36
.....	21.8-24.2	B 40
.....	24.3-26.0	B 45
Following Selections for Size M-1P Only		
23.2-27.1	B 36
27.2-29.2	B 40
29.3-33.0	B 45
33.1-36.0	B 50

Table 2

Motor Full-Load Current (Amp)		Thermal Unit Number
1 T.U.	3 T.U.	
0.35-0.38	0.30-0.32	B 0.44
0.39-0.43	0.33-0.37	B 0.51
0.44-0.48	0.38-0.39	B 0.57
0.49-0.56	0.40-0.48	B 0.63
0.57-0.63	0.49-0.57	B 0.71
0.64-0.71	0.58-0.64	B 0.81
0.72-0.78	0.65-0.70	B 0.92
0.79-0.88	0.71-0.78	B 1.03
0.89-0.99	0.79-0.87	B 1.16
1.00-1.15	0.88-0.98	B 1.30
1.16-1.23	0.99-1.13	B 1.45
1.24-1.43	1.14-1.25	B 1.67
1.44-1.51	1.26-1.40	B 1.88
1.52-1.75	1.41-1.58	B 2.10
1.76-1.93	1.59-1.79	B 2.40
1.94-2.25	1.80-1.91	B 2.65
2.26-2.47	1.92-2.20	B 3.00
2.48-2.81	2.21-2.55	B 3.30
2.82-3.20	2.56-2.87	B 3.70
3.21-3.63	2.88-3.24	B 4.15
3.64-4.19	3.25-3.48	B 4.85
4.20-4.53	3.49-3.85	B 5.50
4.54-4.89	3.86-4.10	B 6.25
4.90-5.68	4.11-4.79	B 6.90
5.69-6.27	4.80-5.31	B 7.70
6.28-6.85	5.32-5.65	B 8.20
6.86-7.73	5.66-6.35	B 9.10
7.74-8.50	6.36-7.31	B 10.2
8.51-9.29	7.32-8.34	B 11.5
9.30-10.4	8.35-8.84	B 12.8
10.5-11.3	8.85-9.47	B 14
11.4-12.3	9.48-10.4	B 15.5
12.4-13.9	10.5-11.5	B 17.5
14.0-15.0	11.6-12.0	B 19.5
15.1-18.0	B 22
Following Selections for Size M-1 & M-1P Only.		
.....	11.6-12.4	B 19.5
15.1-17.4	12.5-14.0	B 22
17.5-19.2	14.1-15.8	B 25
19.3-22.0	15.9-17.8	B 28.0
22.1-24.6	17.9-19.7	B 32
24.7-26.0	19.8-22.4	B 36
.....	22.5-25.1	B 40
.....	25.1-26.0	B 45
Following Selections for Size M-1P Only.		
24.7-29.1	B 36
29.2-31.7	B 40
31.8-36.0	B 45

Table 3

Motor Full-Load Current (Amp)		Thermal Unit Number
1 T.U.	3 T.U.	
0.29-0.31	0.28-0.29	B 0.44
0.32-0.36	0.30-0.33	B 0.51
0.37-0.39	0.34-0.36	B 0.57
0.40-0.47	0.37-0.44	B 0.63
0.48-0.56	0.45-0.52	B 0.71
0.57-0.63	0.53-0.59	B 0.81
0.64-0.69	0.60-0.64	B 0.92
0.70-0.77	0.65-0.71	B 1.03
0.78-0.86	0.72-0.80	B 1.16
0.87-0.97	0.81-0.90	B 1.30
0.98-1.12	0.91-1.03	B 1.45
1.13-1.24	1.04-1.14	B 1.67
1.25-1.39	1.15-1.27	B 1.88
1.40-1.57	1.28-1.44	B 2.10
1.58-1.78	1.45-1.63	B 2.40
1.79-1.96	1.64-1.79	B 2.65
1.97-2.20	1.80-2.01	B 3.00
2.21-2.41	2.02-2.19	B 3.30
2.42-2.75	2.20-2.52	B 3.70
2.76-3.25	2.53-2.95	B 4.15
3.26-3.50	2.96-3.17	B 4.85
3.51-3.87	3.18-3.50	B 5.50
3.88-4.13	3.51-3.73	B 6.25
4.14-4.69	3.74-4.22	B 6.90
4.70-5.20	4.23-4.68	B 7.70
5.21-5.53	4.69-4.98	B 8.20
5.54-6.23	4.99-5.59	B 9.10
6.24-7.18	5.60-6.43	B 10.2
7.19-8.20	6.44-7.41	B 11.5
8.21-8.98	7.42-8.02	B 12.8
8.99-9.63	8.03-8.59	B 14
9.64-10.6	8.60-9.52	B 15.5
10.7-11.8	9.53-10.5	B 17.5
11.9-12.7	10.6-11.2	B 19.5
12.8-14.3	11.3-12.0	B 22
14.4-16.1	B 25
16.2-18.0	B 28.0
Following Selections for Size M-1 & M-1P Only.		
.....	11.3-12.7	B 22
.....	12.8-14.3	B 25
16.2-18.3	14.4-16.1	B 28.0
18.4-20.2	16.2-17.8	B 32
20.3-23.0	17.9-20.1	B 36
23.1-26.0	20.2-22.6	B 40
.....	22.7-25.5	B 45
.....	25.6-26.0	B 50
Following Selections for Size M-1P Only		
25.9-29.0	B 45
29.1-30.8	B 50
30.9-32.7	B 56
32.8-36.0	B 62

Table 4

Motor Full-Load Current (Amp)		Thermal Unit Number
1 T.U.	3 T.U.	
0.32-0.33	0.29-0.30	B 0.44
0.34-0.38	0.31-0.35	B 0.51
0.39-0.41	0.36-0.37	B 0.57
0.42-0.50	0.38-0.45	B 0.63
0.51-0.61	0.46-0.54	B 0.71
0.62-0.68	0.55-0.61	B 0.81
0.69-0.74	0.62-0.66	B 0.92
0.75-0.83	0.67-0.74	B 1.03
0.84-0.93	0.75-0.83	B 1.16
0.94-1.05	0.84-0.93	B 1.30
1.06-1.21	0.94-1.07	B 1.45
1.22-1.34	1.08-1.19	B 1.67
1.35-1.50	1.20-1.33	B 1.88
1.51-1.70	1.34-1.51	B 2.10
1.71-1.93	1.52-1.70	B 2.40
1.94-2.12	1.71-1.87	B 2.65
2.13-2.38	1.88-2.10	B 3.00
2.39-2.61	2.11-2.29	B 3.30
2.62-2.99	2.30-2.63	B 3.70
3.00-3.53	2.64-3.09	B 4.15
3.54-3.80	3.10-3.32	B 4.85
3.81-4.21	3.33-3.67	B 5.50
4.22-4.49	3.68-3.91	B 6.25
4.50-5.10	3.92-4.43	B 6.90
5.11-5.66	4.44-4.91	B 7.70
5.67-6.03	4.92-5.23	B 8.20
6.04-6.79	5.24-5.88	B 9.10
6.80-7.84	5.89-6.77	B 10.2
7.85-8.96	6.78-7.90	B 11.5
8.97-9.82	7.91-8.44	B 12.8
9.83-10.4	8.45-9.05	B 14
10.5-11.6	9.06-9.99	B 15.5
11.7-12.9	10.0-11.0	B 17.5
13.0-13.9	11.1-11.9	B 19.5
14.0-15.7	12.0-12.0	B 22
15.8-18.0	B 25
Following Selections for Size M-1 & M1P Only.		
.....	12.0-13.4	B 22
.....	13.5-15.1	B 25
17.8-20.1	15.2-17.0	B 28.0
20.2-22.2	17.1-18.9	B 32
22.3-25.3	19.0-21.4	B 36
25.4-26.0	21.5-24.0	B 40
.....	24.1-26.0	B 45
Following Selections for Size M-1P Only.		
25.4-28.4	B 40
28.5-33.1	B 45
33.2-36.0	B 50

Table 5

Current Transformer Ratio									Thermal Unit Number	
25/5	50/5	75/5	100/5	150/5	200/5	250/5	300/5	400/5		500/5
Motor Full-Load Current										
10.6-11.7	21.1-23.6	31.7-35.4	42.3-47.2	63.4-70.9	84.5-94.6	106-117.	127.-141.	169.-188.	211.-236.	B 3.00
11.8-13.2	23.7-26.5	35.5-39.8	47.3-53.1	71.0-79.7	94.7-105.	118.-132.	142.-159.	189.-212.	237.-265.	B 3.30
13.3-14.8	26.6-29.6	39.9-44.5	53.2-59.4	79.8-89.1	106.-118.	133.-148.	160.-177.	213.-237.	266.-296.	B 3.70
14.9-17.2	29.7-34.5	44.6-51.8	59.5-69.2	89.2-103.	119.-138.	149.-172.	178.-207.	238.-276.	297.-345.	B 4.15
17.3-19.6	34.6-39.2	51.9-58.9	69.3-78.6	104.-117.	139.-156.	173.-196.	208.-235.	277.-314.	346.-360.	B 4.85
19.7-22.3	39.3-44.6	59.0-67.0	78.7-89.3	118.-133.	157.-178.	197.-223.	236.-267.	315.-357.	B 5.50

Table 6

Current Transformer Ratio									Thermal Unit Number	
25/5	50/5	75/5	100/5	150/5	200/5	250/5	300/5	400/5		500/5
Motor Full-Load Current										
10.6-11.7	21.2-23.9	31.8-35.9	42.4-47.9	63.6-72.0	84.8-96.0	106.-119.	127.-143.	170.-191.	212.-239.	AR 3.62
12.0-13.4	24.0-26.9	36.0-40.3	48.0-53.8	72.1-80.8	96.1-107.	120.-134.	144.-161.	192.-215.	240.-269.	AR 3.98
13.5-15.0	27.0-30.0	40.4-45.1	53.9-60.1	80.9-90.2	108.-119.	135.-150.	162.-180.	216.-240.	270.-300.	AR 4.37
15.1-16.6	30.1-33.4	45.2-50.1	60.2-66.9	90.3-99.4	120.-133.	151.-166.	181.-200.	241.-267.	301.-334.	AR 4.80
16.7-18.7	33.5-37.5	50.2-56.3	67.0-75.1	100.-112.	134.-149.	167.-187.	201.-225.	268.-300.	335.-360.	AR 5.3
18.8-20.7	37.6-41.4	56.4-62.2	75.2-82.9	113.-124.	150.-165.	188.-207.	226.-248.	301.-331.	AR 5.8
20.8-22.8	41.5-45.7	62.3-68.5	83.0-91.4	125.-136.	166.-182.	208.-228.	249.-274.	332.-365.	AR 6.4

Index and Instructions: Pages 18-20



Thermal Unit Selection

Tables 7 thru 12

Table 7

Single Phase				
Single PH Motor Full-Load Current (Amp)	Thermal Unit No.	Maximum Fuse Rating (Amp)		
		Single-Motor Installation (N.E.C. 430-52)	Group Motor Installation (N.E.C. 430-53)	
			Class K-9 or Unclassified Fuse	Class K-5 Fuse
0.33-0.36	B 0.44	0.6	15	30
0.37-0.40	B 0.51	0.8	15	30
0.41-0.45	B 0.57	0.8	15	30
0.46-0.52	B 0.63	1	15	30
0.53-0.59	B 0.71	1.125	15	30
0.60-0.66	B 0.81	1.25	15	30
0.67-0.73	B 0.92	1.4	15	30
0.74-0.81	B 1.03	1.6	15	30
0.82-0.91	B 1.16	1.8	20	30
0.92-1.02	B 1.30	2.0	20	30
1.03-1.14	B 1.45	2.25	20	30
1.15-1.29	B 1.67	2.5	20	30
1.30-1.42	B 1.88	2.8	20	30
1.43-1.64	B 2.10	3.2	25	30
1.65-1.80	B 2.40	3.5	25	30
1.81-2.10	B 2.65	4.0	25	30
2.11-2.30	B 3.00	4.5	25	30
2.31-2.61	B 3.30	5.0	30	30
2.62-2.99	B 3.70	5.6	30	30
3.00-3.37	B 4.15	6.25	30	30
3.38-3.94	B 4.85	7	30	30
3.95-4.24	B 5.50	8	30	30
4.25-4.54	B 6.25	9	30	30
4.55-5.29	B 6.90	10	30	30
5.30-5.73	B 7.70	10	30	30
5.74-6.35	B 8.20	12	30	30
6.36-7.08	B 9.10	12	30	30
7.09-7.83	B 10.2	12	30	30
7.84-8.47	B 11.5	17.5	30	30
8.48-9.83	B 12.8	17.5	30	30
9.84-10.5	B 14	20	Group Fusing Restrictions Maximum thermal unit size: B 12.8	
10.6-11.4	B 15.5	20	Maximum branch-circuit available current: 5,000 Amp symmetrical	
11.5-12.8	B 17.5	25		
12.9-13.9	B 19.5	25		
14.0-16.1	B 22	25		
16.2-18.0	B 25	25		

Polyphase					
Single PH Motor Full-Load Current (Amp)	Thermal Unit No.	Maximum Fuse Rating (Amp)			
		Single-Motor Installation (N.E.C. 430-52)	Group Motor Installation (N.E.C. 430-53)		
			Class K-9 or Unclassified Fuse	Class K-5 Fuse	
0.29-0.32	B 0.44	0.6	15	30	
0.33-0.36	B 0.51	0.6	15	30	
0.37-0.39	B 0.57	0.8	15	30	
0.40-0.47	B 0.63	0.8	15	30	
0.53-0.59	B 0.71	1	15	30	
0.57-0.63	B 0.81	1.25	15	30	
0.64-0.69	B 0.92	1.4	15	30	
0.70-0.77	B 1.03	1.4	15	30	
0.78-0.86	B 1.16	1.6	20	30	
0.87-0.96	B 1.30	1.8	20	30	
0.97-1.11	B 1.45	2	20	30	
1.12-1.23	B 1.67	2.5	20	30	
1.24-1.37	B 1.88	2.5	20	30	
1.38-1.55	B 2.10	2.8	25	30	
1.56-1.75	B 2.40	3.5	25	30	
1.76-1.92	B 2.65	3.5	25	30	
1.93-2.16	B 3.00	4	25	30	
2.17-2.50	B 3.30	4.5	30	30	
2.51-2.81	B 3.70	5.6	30	30	
2.82-3.16	B 4.15	6.25	30	30	
3.17-3.40	B 4.85	7	30	30	
3.41-3.76	B 5.50	7	30	30	
3.77-4.00	B 6.25	8	30	30	
4.01-4.68	B 6.90	9	30	30	
4.69-5.18	B 7.70	10	30	30	
5.19-5.51	B 8.20	10	30	30	
5.52-6.19	B 9.10	12	30	30	
6.20-7.12	B 10.2	12	30	30	
7.13-8.15	B 11.5	15	30	30	
8.16-8.60	B 12.8	17.5	30	30	
10.2-11.2	B 14	17.5	30	30	
9.22-10.1	B 15.5	20	Group Fusing Restrictions Maximum thermal unit size: B 14		
10.2-11.2	B 17.5	200 V Max.	Maximum branch-circuit available current: 5,000 Amp symmetrical		
11.3-12.0	B 19.5	250 V Max. 25			

Table 8

Motor Full-Load Current (Amp)			Thermal Unit Number
2 T.U. 1 PH	2 T.U. 2 PH	3 T.U.	
0.37-0.39	0.37-0.39	0.30-0.31	AR .45
0.40-0.42	0.40-0.42	0.32-0.34	AR .49
0.43-0.46	0.43-0.46	0.35-0.37	AR .54
0.47-0.50	0.47-0.50	0.38-0.41	AR .59
0.51-0.54	0.51-0.54	0.42-0.45	AR .65
0.55-0.59	0.55-0.59	0.46-0.49	AR .71
0.60-0.65	0.60-0.65	0.50-0.54	AR .78
0.66-0.71	0.66-0.71	0.55-0.56	AR .86
0.72-0.78	0.72-0.78	0.57-0.62	AR .95
0.79-0.86	0.79-0.86	0.63-0.68	AR 1.05
0.87-0.94	0.87-0.94	0.69-0.75	AR 1.15
0.95-1.04	0.95-1.04	0.76-0.82	AR 1.26
1.05-1.14	1.05-1.14	0.83-0.91	AR 1.39
1.15-1.25	1.15-1.25	0.92-1.00	AR 1.53
1.26-1.42	1.26-1.42	1.01-1.18	AR 1.68
1.43-1.62	1.43-1.62	1.19-1.30	AR 1.85
1.63-1.75	1.63-1.75	1.31-1.41	AR 2.04
1.76-1.91	1.76-1.91	1.42-1.53	AR 2.24
1.92-2.07	1.92-2.07	1.54-1.69	AR 2.46
2.08-2.25	2.08-2.25	1.70-1.79	AR 2.71
2.26-2.47	2.26-2.47	1.80-2.02	AR 2.98
2.48-2.73	2.48-2.73	2.03-2.19	AR 3.28
2.74-2.99	2.74-2.99	2.20-2.43	AR 3.62
3.00-3.31	3.00-3.31	2.44-2.81	AR 3.98
3.32-3.71	3.32-3.71	2.82-3.12	AR 4.37
3.72-4.15	3.72-4.15	3.13-3.47	AR 4.80
4.16-4.65	4.16-4.65	3.48-3.89	AR 5.3
4.66-5.11	4.66-5.11	3.90-4.30	AR 5.8
5.12-5.68	5.12-5.68	4.31-4.69	AR 6.4
5.69-6.24	5.69-6.24	4.70-5.19	AR 7.0
6.25-7.15	6.25-7.15	5.20-5.93	AR 7.7
7.16-7.84	7.16-7.84	5.94-6.45	AR 8.5
7.85-8.56	7.85-8.56	6.46-7.08	AR 9.3
8.57-9.40	8.57-9.40	7.09-7.71	AR 10.2
9.41-10.2	9.41-10.2	7.72-8.39	AR 11.2
10.3-10.7	10.3-10.7	8.40-8.64	AR 12.4
10.8-12.2	10.8-12.2	8.65-9.74	AR 13.6
12.3-14.1	9.75-11.0	AR 15.4
14.2-15.9	11.1-12.0	AR 17.6
16.0-18.0	AR 20.5
Following Selections for Size 1 Only			
.....	10.8-12.2	AR 13.6
.....	12.3-14.4	AR 15.4
.....	14.2-15.9	11.1-12.4	AR 17.6
16.0-18.1	16.0-18.1	12.5-13.9	AR 20.5
18.2-20.8	18.2-20.8	14.0-15.9	AR 23
20.9-23.6	20.9-23.6	16.0-17.7	AR 27
23.7-26.0	23.7-26.0	17.8-20.3	AR 30
.....	20.4-22.8	AR 35
.....	22.9-26.0	AR 40

Table 9

Motor Full-Load Current (Amp)	Thermal Unit Number
15.3-16.7	C 20
16.8-19.8	C 22
19.9-22.8	C 26
22.9-25.8	C 30
25.9-30.4	C 34
30.5-31.9	C 40
32.0-34.2	C 42
34.3-38.8	C 45
38.9-44.2	C 51
44.3-50.2	C 58
50.3-57.1	C 66
57.2-63.2	C 75
63.3-68.6	C 83
68.7-78.6	C 90
78.7-86.9	C 103
87.0-100.0	C 114

Table 10

Motor Full-Load Current (Amp)	Thermal Unit Number
43.6-47.3	CC 54.5
47.4-51.3	CC 59.4
51.4-54.6	CC 64.3
54.7-59.7	CC 68.5
59.8-65.1	CC 74.6
65.2-70.1	CC 81.5
70.2-75.1	CC 87.7
75.2-82.2	CC 94.0
82.3-89.2	CC 103
89.3-96.5	CC 112
96.6-104.	CC 121
105.-113.	CC 132
114.-123.	CC 143
124.-132.	CC 156
133.-150.	CC 167

Table 11

Motor Full-Load Current (Amp)		Thermal Unit Number
2 T.U.	3 T.U.	
33.0-36.1	30.5-33.4	AU 44
36.2-40.2	33.5-37.1	AU 50
40.3-44.5	37.2-42.0	AU 56
45.6-51.3	42.1-47.0	AU 64
51.4-58.5	47.1-53.5	AU 72
58.6-62.6	53.6-57.5	AU 81
62.7-71.3	57.6-64.4	AU 88
71.4-77.1	64.5-69.4	AU 99
77.2-86.9	69.5-77.4	AU 110
87.0-93.3	77.5-83.6	AU 123
93.4-102.	83.7-92.9	AU 135
103.-107.	93.0-100.	AU 152
108.-112.	101.-104.	AU 169
113.-121.	105.-115.	AU 183
122.-123.	116.-119.	AU 198
124.-133.	120.-123.	AU 217
.....	124.-133.	AU 235

Table 12

Motor Full-Load Current (Amp)	Thermal Unit Number
92.-100.	DD 122
101.-109.	DD 121
110.-119.	DD 128
120.-131.	DD 140
132.-139.	DD 150
140.-156.	DD 160
157.-166.	DD 185
167.-180.	DD 213
181.-189.	DD 220
190.-209.	DD 230
210.-225.	DD 250
226.-238.	DD 265
239.-263.	DD 280
264.-300.	DD 300



Thermal Unit Selection Tables 13 thru 18

Table 13

Motor Full-Load Current (Amp)			Thermal Unit Number
1.T.U.	2.T.U.	3.T.U.	
0.29-0.31	0.29-0.31	0.28-0.30	B 0.44
0.32-0.34	0.32-0.34	0.31-0.34	B 0.51
0.65-0.38	0.35-0.38	0.35-0.37	B 0.57
0.39-0.45	0.39-0.45	0.38-0.44	B 0.63
0.46-0.54	0.46-0.54	0.45-0.53	B 0.71
0.55-0.61	0.55-0.61	0.54-0.59	B 0.81
0.62-0.66	0.62-0.66	0.60-0.64	B 0.92
0.67-0.73	0.67-0.73	0.65-0.72	B 1.03
0.74-0.81	0.74-0.81	0.73-0.80	B 1.16
0.82-0.94	0.82-0.94	0.81-0.90	B 1.30
0.95-1.05	0.95-1.05	0.91-1.03	B 1.45
1.06-1.22	1.06-1.22	1.04-1.14	B 1.67
1.23-1.34	1.23-1.34	1.15-1.27	B 1.88
1.35-1.51	1.35-1.51	1.28-1.43	B 2.10
1.52-1.71	1.52-1.71	1.44-1.62	B 2.40
1.72-1.93	1.72-1.93	1.63-1.77	B 2.65
1.94-2.14	1.94-2.14	1.78-1.97	B 3.00
2.15-2.40	2.15-2.40	1.98-2.32	B 3.30
2.41-2.72	2.41-2.72	2.33-2.51	B 3.70
2.73-3.15	2.73-3.15	2.52-2.99	B 4.15
3.16-3.55	3.16-3.55	3.00-3.42	B 4.85
3.56-4.00	3.56-4.00	3.43-3.75	B 5.50
4.01-4.40	4.01-4.40	3.76-3.98	B 6.25
4.41-4.88	4.41-4.88	3.99-4.48	B 6.90
4.89-5.19	4.89-5.19	4.49-4.93	B 7.70
5.20-5.73	5.20-5.73	4.94-5.21	B 8.20
5.74-6.39	5.74-6.39	5.22-5.84	B 9.10
6.40-7.13	6.40-7.13	5.85-6.67	B 10.2
7.14-7.90	7.14-7.90	6.68-7.54	B 11.5
7.91-8.55	7.91-8.55	7.55-8.14	B 12.8
8.56-9.53	8.56-9.53	8.15-8.72	B 14
9.54-10.6	9.54-10.6	8.73-9.66	B 15.5
10.7-11.8	10.7-11.8	9.67-10.5	B 17.5
11.9-13.2	11.9-13.2	10.6-11.3	B 19.5
13.3-14.9	11.4-12.0	B 22
15.0-16.6	B 25
16.7-18.0	B 28.0

Following Selections for Size 1 Only

....	11.9-13.2	B 19.5
....	13.3-14.9	11.4-12.7	B 22
....	15.0-16.6	12.8-14.1	B 25
....	16.7-18.9	14.2-15.9	B 28.0
19.0-21.2	19.0-21.2	16.0-17.5	B 32
21.3-23.0	21.3-23.0	17.6-19.7	B 36
23.1-25.5	23.1-25.5	19.8-21.9	B 40
25.6-26.0	25.6-26.0	22.0-24.4	B 45
....	24.5-26.0	B 50

Table 16

Motor Full-Load Current (Amp)			Thermal Unit Number
1.T.U.	2.T.U.	3.T.U.	
16.2-17.5	15.1-16.2	14.3-15.4	CC 20.9
17.6-18.8	16.3-17.3	15.5-16.4	CC 22.8
18.9-20.5	17.4-19.5	16.5-18.5	CC 24.6
20.6-22.2	19.5-20.7	18.6-19.6	CC 26.3
22.3-23.7	20.8-22.3	19.7-21.1	CC 28.8
23.8-25.4	22.4-24.0	21.2-22.7	CC 31.0
25.5-27.3	24.1-25.7	22.8-24.4	CC 33.3
27.4-29.3	25.8-27.5	24.5-26.1	CC 36.4
29.4-31.4	27.6-29.6	26.2-28.1	CC 39.6
31.6-33.9	29.7-31.7	28.2-30.0	CC 42.7
34.0-36.2	31.8-33.9	30.1-32.1	CC 46.6
36.3-39.3	34.0-36.6	32.2-34.7	CC 50.1
39.4-42.3	36.7-39.3	34.8-37.3	CC 54.5
42.4-45.3	39.4-42.3	37.4-40.1	CC 59.4
45.4-48.3	42.4-44.9	40.2-42.6	CC 64.3
48.4-52.0	45.0-48.3	42.7-45.8	CC 68.5
52.1-54.9	48.4-50.9	45.9-48.3	CC 74.6
55.0-59.7	51.0-55.5	48.4-52.6	CC 81.5
59.8-65.4	55.6-59.9	52.7-56.8	CC 87.7
65.5-69.6	60.0-64.2	56.9-60.9	CC 94.0
69.7-74.8	64.3-68.7	61.0-65.1	CC 103
74.9-79.7	68.8-71.4	65.2-67.7	CC 112
79.8-83.1	71.5-74.8	67.8-70.9	CC 121
83.2-86.0	74.9-78.0	71.0-73.9	CC 132
....	78.1-80.7	74.0-76.5	CC 143
....	80.8-86.0	76.6-80.2	CC 156
....	80.3-83.1	CC 167
....	83.2-86.0	CC 180

Table 14

Motor Full-Load Current (Amp)			Thermal Unit Number
1.T.U.	2.T.U.	3.T.U.	
0.43-0.47	0.41-0.45	0.40-0.41	A .49
0.48-0.51	0.46-0.50	0.42-0.46	A .54
0.52-0.56	0.51-0.55	0.47-0.51	A .59
0.57-0.64	0.56-0.62	0.52-0.57	A .65
0.65-0.69	0.63-0.67	0.58-0.62	A .71
0.70-0.76	0.68-0.72	0.63-0.67	A .78
0.77-0.84	0.73-0.81	0.68-0.75	A .86
0.85-0.91	0.82-0.88	0.76-0.80	A .95
0.92-1.01	0.89-0.97	0.81-0.89	A 1.02
1.02-1.15	0.96-1.08	0.90-1.02	A 1.16
1.16-1.23	1.09-1.18	1.03-1.09	A 1.25
1.24-1.37	1.19-1.32	1.10-1.21	A 1.39
1.38-1.45	1.33-1.40	1.22-1.29	A 1.54
1.46-1.56	1.41-1.48	1.30-1.37	A 1.63
1.57-1.67	1.49-1.60	1.38-1.48	A 1.75
1.68-1.77	1.61-1.72	1.49-1.58	A 1.86
1.78-1.92	1.73-1.84	1.59-1.72	A 1.99
1.93-2.09	1.85-2.00	1.73-1.85	A 2.15
2.10-2.31	2.01-2.22	1.86-2.05	A 2.31
2.32-2.56	2.23-2.45	2.06-2.29	A 2.57
2.57-2.92	2.46-2.82	2.30-2.62	A 2.81
2.93-3.16	2.83-3.08	2.63-2.84	A 3.61
3.17-3.48	3.09-3.39	2.85-3.10	A 3.95
3.49-3.83	3.40-3.75	3.11-3.46	A 4.32
3.84-4.24	3.76-4.16	3.47-3.85	A 4.79
4.25-4.62	4.17-4.51	3.86-4.16	A 5.30
4.63-4.92	4.52-4.83	4.17-4.46	A 5.78
4.93-5.61	4.84-5.49	4.47-5.08	A 6.20
5.62-5.85	5.50-5.67	5.09-5.35	A 6.99
5.86-6.36	5.68-6.16	5.36-5.82	A 7.65
6.37-6.99	6.17-6.75	5.83-6.34	A 8.38
7.00-7.67	6.76-7.00	6.35-6.95	A 9.25
7.68-8.15	6.96-7.00	A 9.85
8.16-9.00	A 11.0

Table 17

Motor Full-Load Current (Amp)			Thermal Unit Number
1.T.U.	2.T.U.	3.T.U.	
0.42-0.46	0.39-0.43	0.38-0.40	A .49
0.47-0.50	0.44-0.47	0.41-0.44	A .54
0.51-0.55	0.48-0.52	0.45-0.49	A .59
0.56-0.62	0.53-0.58	0.50-0.55	A .65
0.63-0.67	0.59-0.64	0.56-0.60	A .71
0.68-0.73	0.65-0.68	0.61-0.65	A .78
0.74-0.81	0.69-0.77	0.66-0.72	A .86
0.82-0.89	0.78-0.84	0.73-0.79	A .95
0.90-0.98	0.85-0.93	0.80-0.88	A 1.02
0.99-1.12	0.94-1.05	0.89-0.98	A 1.16
1.13-1.20	1.06-1.13	0.99-1.07	A 1.25
1.21-1.34	1.14-1.25	1.08-1.17	A 1.39
1.35-1.41	1.26-1.33	1.18-1.25	A 1.54
1.42-1.51	1.34-1.42	1.26-1.33	A 1.63
1.52-1.62	1.43-1.52	1.34-1.44	A 1.75
1.63-1.73	1.53-1.63	1.45-1.53	A 1.86
1.74-1.86	1.64-1.75	1.54-1.65	A 1.99
1.87-2.02	1.76-1.90	1.66-1.79	A 2.15
2.03-2.25	1.91-2.13	1.80-1.99	A 2.31
2.26-2.46	2.14-2.33	2.00-2.18	A 2.57
2.47-2.77	2.34-2.73	2.19-2.45	A 2.81
2.78-2.99	2.74-2.86	2.46-2.65	A 3.61
3.00-3.26	2.87-3.14	2.66-2.90	A 3.95
3.27-3.59	3.15-3.47	2.91-3.19	A 4.32
3.60-3.99	3.48-3.83	3.20-3.56	A 4.79
4.00-4.42	3.84-4.16	3.57-3.83	A 5.30
4.43-4.61	4.17-4.43	3.84-4.08	A 5.78
4.62-5.23	4.44-5.00	4.09-4.64	A 6.20
5.24-5.39	5.01-1.56	4.65-5.00	A 6.99
5.40-5.88	5.17-5.56	5.01-5.36	A 7.65
5.89-6.56	5.57-6.22	5.37-5.87	A 8.38
6.57-7.18	6.23-6.89	5.88-6.43	A 9.25
7.19-7.80	6.90-7.00	6.44-6.79	A 9.85
7.81-9.00	6.80-7.00	A 11.0

Table 15

Motor Full-Load Current (Amp)			Thermal Unit Number
1.T.U.	2.T.U.	3.T.U.	
0.31-0.33	0.31-0.33	0.29-0.31	B 0.44
0.34-0.36	0.34-0.36	0.32-0.36	B 0.51
0.37-0.40	0.37-0.40	0.37-0.38	B 0.57
0.41-0.48	0.41-0.48	0.39-0.46	B 0.63
0.49-0.57	0.49-0.57	0.47-0.55	B 0.71
0.58-0.64	0.58-0.64	0.56-0.61	B 0.81
0.65-0.70	0.65-0.70	0.62-0.66	B 0.92
0.71-0.77	0.71-0.77	0.67-0.75	B 1.03
0.78-0.85	0.78-0.85	0.76-0.83	B 1.16
0.86-0.99	0.86-0.99	0.84-0.93	B 1.30
1.00-1.10	1.00-1.10	0.94-1.06	B 1.45
1.11-1.28	1.11-1.28	1.07-1.18	B 1.67
1.29-1.41	1.29-1.41	1.19-1.31	B 1.88
1.42-1.58	1.42-1.58	1.32-1.47	B 2.10
1.59-1.80	1.59-1.80	1.48-1.67	B 2.40
1.81-2.03	1.81-2.03	1.68-1.83	B 2.65
2.04-2.25	2.04-2.25	1.84-2.04	B 3.00
2.26-2.51	2.26-2.51	2.05-2.38	B 3.30
2.52-2.83	2.52-2.83	2.38-2.60	B 3.70
2.84-3.29	2.84-3.29	2.61-3.13	B 4.15
3.30-3.75	3.30-3.75	3.14-3.59	B 4.85
3.76-4.22	3.76-4.22	3.60-3.94	B 5.50
4.23-4.65	4.23-4.65	3.95-4.19	B 6.25
4.66-5.16	4.66-5.16	4.20-4.72	B 6.90
5.17-5.53	5.17-5.53	4.73-5.21	B 7.70
5.54-6.09	5.54-6.09	5.22-5.51	B 8.20
6.10-6.80	6.10-6.80	5.52-6.17	B 9.10
6.81-7.60	6.81-7.60	6.18-7.07	B 10.2
7.61-8.35	7.61-8.35	7.08-8.05	B 11.5
8.36-9.04	8.36-9.04	8.06-8.69	B 12.8
9.05-9.99	9.05-9.99	8.70-9.32	B 14
10.0-11.1	10.0-11.1	9.33-10.2	B 15.5
11.2-12.3	11.2-12.0	10.3-11.3	B 17.5
12.4-13.7	11.4-12.0	B 19.5
13.8-15.4	B 22
15.5-18.0	B 25

Following Selections for Size 1 Only

....	11.2-12.3	B 17.5
....	12.4-13.7	11.4-12.1	B 19.5
....	13.8-15.4	12.2-13.7	B 22
15.5-17.2	15.5-17.2	13.8-15.2	B 25
17.3-19.4	17.3-19.4	15.3-17.2	B 28.0
19.5-21.7	19.5-21.7	17.3-18.9	B 32
21.8-23.9	21.8-23.9	19.0-21.4	B 36
24.0-26.0	24.0-26.0	21.5-23.7	B 40
....	23.8-26.0	B 45

Table 18

Motor Full-Load Current (Amp)			Thermal Unit Number
1.T.U.	2.T.U.	3.T.U.	
15.5-16.4	14.4-15.3	13.6-14.5	CC 20.9
16.5-17.6	15.4-16.4	14.6-15.5	CC 22.8
17.7-19.1	16.5-18.4	15.6-17.4	CC 24.6
19.2-20.4	18.5-19.6	17.5-18.5	CC 26.3
20.5-22.1	19.7-21.0	18.6-19.9	CC 28.8
22.2-23.4	21.1-22.7	20.0-21.5	CC 31.0
23.5-25.6	22.8-24.2	21.6-22.9	CC 33.3
25.7-27.3	24.3-25.9	23.0-24.5	CC 36.4
27.4-29.4	26.0-27.8	24.6-26.3	CC 39.6
29.5-31.5	27.9-29.8	26.4-28.2	CC 42.7
31.6-33.7	29.9-31.7	28.3-30.0	CC 46.6
33.8-36.5	31.8-34.2	30.1-32.3	CC 50.1
36.6-39.1	34.3-36.9	32.4-34.9	CC 54.5
39.2-41.7	37.0		

Thermal Unit Selection

Tables 19 thru 30

Table 19

Motor Full-Load Current (Amp)	Thermal Unit Number
43.6-47.3	CC 54.5
47.4-51.3	CC 59.4
51.4-54.6	CC 64.3
54.7-59.7	CC 68.5
59.8-65.1	CC 74.6
65.2-70.1	CC 81.5
70.2-75.1	CC 87.7
75.2-82.2	CC 94.0
82.3-89.2	CC 103
89.3-96.5	CC 112
96.6-104.	CC 121
105.-113.	CC 132
114.-123.	CC 143
124.-133.	CC 156

Table 23

Motor Full-Load Current (Amp)		Thermal Unit Number
2 or 3 T.U.		
Large Enclosure	Small Enclosure	
0.31-0.32	0.29-0.30	AR .45
0.33-0.36	0.31-0.33	AR .49
0.37-0.39	0.34-0.37	AR .54
0.40-0.43	0.38-0.41	AR .59
0.44-0.47	0.42-0.45	AR .65
0.48-0.52	0.46-0.50	AR .71
0.53-0.58	0.51-0.55	AR .78
0.59-0.60	0.56-0.57	AR .86
0.61-0.62	0.58-0.60	AR .95
0.63-0.69	0.61-0.66	AR 1.05
0.70-0.76	0.67-0.73	AR 1.15
0.77-0.84	0.74-0.81	AR 1.26
0.85-0.93	0.82-0.90	AR 1.39
0.94-1.03	0.91-0.99	AR 1.53
1.04-1.23	1.00-1.18	AR 1.68
1.24-1.35	1.19-1.30	AR 1.85
1.36-1.47	1.31-1.42	AR 2.04
1.48-1.61	1.43-1.49	AR 2.24
1.62-1.76	1.50-1.69	AR 2.46
1.77-1.93	1.70-1.85	AR 2.71
1.94-2.12	1.86-2.03	AR 2.98
2.13-2.35	2.04-2.25	AR 3.28
2.36-2.61	2.26-2.50	AR 3.62
2.62-2.79	2.51-2.68	AR 3.98
2.80-3.14	2.69-3.01	AR 4.37
3.15-3.48	3.02-3.35	AR 4.80
3.49-3.89	3.36-3.74	AR 5.3
3.90-4.30	3.75-4.14	AR 5.8
4.31-4.73	4.15-4.57	AR 6.4
4.74-5.20	4.58-5.03	AR 7.0
5.21-5.95	5.04-5.76	AR 7.7
5.96-6.49	5.77-6.29	AR 8.5
6.50-7.08	6.30-6.87	AR 9.3
7.09-7.77	6.88-7.54	AR 10.2
7.78-8.48	7.55-8.25	AR 11.2
8.49-9.15	8.26-8.60	AR 12.4
9.16-10.3	8.61-9.63	AR 13.6
10.4-11.9	9.64-11.1	AR 15.4
12.0-13.4	11.2-12.5	AR 17.6
13.5-15.4	12.6-14.3	AR 20.5
15.5-17.5	14.4-16.1	AR 23
17.6-19.8	16.2-18.2	AR 27
19.9-22.5	18.3-20.6	AR 30
22.6-26.0	20.7-23.4	AR 35
....	23.5-26.0	AR 40

Table 20

Motor Full-Load Current (Amp)	Thermal Unit Number
133.-148.	B 1.30
149.-174.	B 1.45
175.-195.	B 1.67
196.-219.	B 1.88
220.-239.	B 2.10
240.-271.	B 2.40
272.-308.	B 2.65
309.-348.	B 3.00
349.-397.	B 3.30
398.-429.	B 3.70
430.-495.	B 4.15
496.-520.	B 4.85

Table 24

Motor Full-Load Current (Amp)	Thermal Unit Number
88.2-95.1	DD 112
95.2-1.10	DD 121
102.-111.	DD 128
112.-119.	DD 140
120.-131.	DD 150
132.-149.	DD 160
150.-170.	DD 185
171.-180.	DD 220
181.-197.	DD 240
198.-204.	DD 250
205.-213.	DD 265
214.-237.	DD 280
238.-243.	DD 300
244.-266.	DD 320

Table 27

Motor Full-Load Current (Amp)		Thermal Unit Number
2 or 3 T.U.		
Large Enclosure	Small Enclosure	
4.32-4.93	4.14-4.71	AR 8.5
4.94-5.40	4.72-5.18	AR 9.3
5.41-5.95	5.19-5.74	AR 10.2
5.96-6.13	5.75-5.98	AR 11.2
6.14-6.81	5.99-6.47	AR 12.4
6.82-7.84	6.48-7.42	AR 13.6
7.85-8.97	7.43-8.46	AR 15.4
8.98-10.1	8.47-9.56	AR 17.6
10.2-11.6	9.57-10.9	AR 20.5
11.7-13.2	11.0-12.3	AR 23
13.3-15.0	12.4-14.0	AR 27
15.1-17.1	14.1-15.9	AR 30
17.2-19.6	16.0-18.1	AR 35
19.7-21.9	18.2-20.3	AR 40
22.0-23.8	20.4-22.0	AR 44
23.9-25.6	22.1-23.6	AR 47
25.7-27.9	23.7-25.5	AR 51
28.0-30.5	25.6-27.8	AR 55
30.6-33.0	27.9-30.0	AR 60
33.1-35.7	30.1-32.4	AR 66
35.8-39.5	32.5-35.7	AR 72
39.6-41.5	35.8-38.3	AR 79
41.6-45.0	38.4-40.9	AR 86
....	41.6-45.0	AR 94

Table 21

Motor Full-Load Current (Amp)	Thermal Unit Load
128.140.	B 1.30
141.-163.	B 1.45
164.-179	B 1.67
1.80-201.	B 1.88
202.-227.	B 2.01
228.-251.	B 2.40
252.-278.	B 2.65
279.-308.	B 3.00
309.-346.	B 3.30
347.-380.	B 3.70
381.-426.	B 4.15
427.-454.	B 4.85
455.-489.	B 5.50
490.-520.	B 6.25

Table 25

Motor Full-Load Current (Amp)	Thermal Unit Number
0.28-0.30	AR .45
0.31-0.33	AR .49
0.34-0.36	AR .54
0.37-0.39	AR .59
0.40-0.42	AR .65
0.43-0.46	AR .71
0.47-0.50	AR .78
0.51-0.52	AR .86
0.53-0.56	AR .95
0.57-0.60	AR 1.05
0.61-0.66	AR 1.15
0.67-0.73	AR 1.26
0.74-0.81	AR 1.39
0.82-0.90	AR 1.53
0.91-1.05	AR 1.68
10.6-1.15	AR 1.85
1.16-1.25	AR 2.04
1.26-1.35	AR 2.24
1.36-1.47	AR 2.46
1.48-1.56	AR 2.71
1.59-1.74	AR 2.98
1.75-1.94	AR 3.28
1.95-2.20	AR 3.62
2.21-2.47	AR 3.98
2.48-2.96	AR 4.37
2.77-3.07	AR 4.80
3.08-3.45	AR 5.3
3.46-3.81	AR 5.3
3.46-3.81	AR 5.8
3.82-4.20	AR 6.4
4.21-4.65	AR 7.0
4.66-5.29	AR 7.7
5.30-5.84	AR 8.5
5.85-6.27	AR 9.3
6.28-7.00	AR 10.2

Table 28

Motor Full-Load Current (Amp)		Thermal Unit Number
2 or 3 T.U.		
Large Enclosure	Small Enclosure	
45.3-48.2	40.3-42.8	CC 64.3
48.3-52.4	42.9-46.2	CC 68.5
52.5-56.4	46.3-49.8	CC 74.6
56.5-61.2	49.9-54.9	CC 81.5
61.3-66.1	55.0-57.9	CC 87.7
66.2-71.4	58.0-62.5	CC 94.0
71.5-77.0	62.6-67.3	CC 103
77.1-80.7	67.4-73.4	CC 112
80.8-87.7	73.5-78.9	CC 121
87.8-94.9	79.0-84.9	CC 132
95.0-102.	85.0-91.0	CC 143
103.-110.	91.1-97.2	CC 156
111.-117.	97.3-104.	CC 167
118.-133.	105.-121.	CC 180
....	122.-133.	CC 196

Table 22

Motor Full-Load Current (Amp)	Thermal Unit Number
92.0-100.	DD 112
101.-109.	DD 121
110.-119.	DD 128
120.-131.	DD 140
132.-139.	DD 150
140.-156.	DD 160
157.-166.	DD 185
167.-180.	DD 213
181.-189.	DD 220
190.-209.	DD 230
210.-225.	DD 250
226.-238.	DD 265
239.-266.	DD 280

Table 26

Size 7	Size 8	Thermal Unit Number
Type J	Type K	
Current Transformer Ratio		
120/5	2000/5	
Motor Full-Load Current		
166.-187.	277.-312.	B 1.03
188.-211.	313.-352.	B 1.16
212.-232.	353.-388.	B 1.30
233.-267.	389.-445.	B 1.45
268.-301.	446.-503.	B 1.67
302.-336.	504.-561.	B 1.88
337.-383.	562.-640.	B 2.10
384.-425.	641.-708.	B 2.40
426.-466.	709.-777.	B 2.65
467.-522.	778.-870.	B 3.00
523.-587.	871.-978.	B 3.30
588.-656.	979.-1093.	B 3.70
657.-764.	1094.-1215.	B 4.15

Table 29

Motor Full-Load Current	Thermal Unit Number
50.0-55.9	E 88
56.0-60.9	E 89
61.0-65.9	E 91
66.0-69.9	E 92
70.0-75.9	E 93
76.0-81.9	E 94
82.0-86.9	E 96
87.0-92.9	E 97
93.0-97.9	E 98
98.0-107.9	E 99
108.0-113.9	E 101
114.0-125.9	E 102

Table 30

Motor Full-Load Current (Amp)		Thermal Unit Number
Large Enclosure	Small Enclosure	
39.0-42.9	37.0-40.8	AU 44
43.0-48.0	40.9-45.6	AU 50
48.1-54.7	45.7-51.8	AU 56
54.8-62.2	51.9-58.8	AU 64
62.3-71.3	58.9-67.4	AU 72
71.4-76.0	67.5-70.4	AU 81
76.1-85.5	70.5-79.4	AU 88
85.6-92.4	79.5-86.3	AU 99
92.4-103.	86.4-96.7	AU 110
104.-111.	96.8-105.	AU 123
112.-123.	106.-117.	AU 135
124.-133.	118.-133.	AU 152



Thermal Unit Selection Tables 31 thru 41

Table 31

Motor Full-Load Current (Amp)	Thermal Unit Number
0.31-0.35	B 0.44
0.36-0.39	B 0.51
0.40-0.44	B 0.57
0.45-0.50	B 0.63
0.51-0.61	B 0.71
0.62-0.68	B 0.81
0.69-0.73	B 0.92
0.74-0.82	B 1.03
0.83-0.92	B 1.16
0.93-1.03	B 1.30
1.04-1.19	B 1.45
1.20-1.34	B 1.67
1.35-1.50	B 1.88
1.51-1.74	B 2.10
1.75-1.97	B 2.40
1.98-2.14	B 2.65
2.15-2.47	B 3.00
2.48-2.91	B 3.30
2.92-3.31	B 3.70
3.32-3.75	B 4.15
3.76-4.05	B 4.85
4.06-4.94	B 6.25
4.95-5.52	B 6.90
5.53-6.11	B 7.70
6.12-6.52	B 8.20
6.53-7.31	B 9.10
7.32-8.43	B 10.2
8.44-9.83	B 11.5
9.84-10.7	B 12.8
10.8-11.6	B 14
11.7-12.9	B 15.5
13.0-14.3	B 17.5
14.4-15.7	B 19.5
15.8-17.8	B 22
17.9-20.3	B 25
20.4-23.3	B 28.0
23.4-26.6	B 32
26.7-30.3	B 36
30.4-35.3	B 40
35.4-41.5	B 45
41.6-45	B 50

Table 35

Motor Full-Load Current (Amp)		Thermal Unit Number
2 T.U.	3 T.U.	
36.3-39.9	34.7-37.1	AU 44
40.0-44.1	37.2-41.5	AU 50
44.2-50.0	41.6-47.1	AU 56
50.1-56.4	47.2-53.4	AU 64
56.5-64.4	53.5-60.7	AU 72
64.5-68.4	60.8-64.9	AU 81
68.5-77.7	65.0-73.4	AU 88
77.8-84.2	73.5-79.5	AU 99
84.3-94.8	79.6-89.0	AU 110
94.9-101.	89.1-96.9	AU 123
102.-115.	97.0-108.	AU 135
116.-122.	109.-115.	AU 152
123.-133.	116.-120.	AU 169
....	121.-133.	AU 183

Table 38

Motor Full-Load Current (Amp)	Thermal Unit Number
85.0-95.	AF 123
96.0-108.	AF 135
109.-127.	AF 150
128.-136.	AF 159
137.-147.	AF 168
148.-162.	AF 188
163.-185.	AF 205
186.-202.	AF 220
203.-219.	AF 240
220.-233.	AF 260
234.-266.	AF 308

Table 32

Motor Full-Load Current (Amp)	Thermal Unit Number
0.33-0.35	AR .45
0.36-0.39	AR .49
0.40-0.42	AR .54
0.43-0.46	AR .59
0.47-0.51	AR .65
0.52-0.56	AR .71
0.57-0.62	AR .78
0.63-0.68	AR .86
0.69-0.75	AR .95
0.76-0.83	AR 1.05
0.84-0.91	AR 1.15
0.92-1.00	AR 1.26
1.01-1.10	AR 1.39
1.11-1.21	AR 1.53
1.22-1.33	AR 1.68
1.34-1.47	AR 1.85
1.48-1.62	AR 2.04
1.62-1.77	AR 2.24
1.78-1.96	AR 2.46
1.97-2.16	AR 2.71
2.17-2.37	AR 2.98
2.38-2.62	AR 3.28
2.63-2.88	AR 3.62
2.89-3.17	AR 3.98
3.18-3.48	AR 4.37
3.49-3.83	AR 4.80
3.84-4.20	AR 5.3
4.21-4.62	AR 5.8
4.63-5.08	AR 6.4
5.09-5.57	AR 7.0
5.58-6.13	AR 7.7
6.14-6.83	AR 8.5
6.84-7.41	AR 9.3
7.42-8.05	AR 10.2
8.06-8.98	AR 11.2
8.99-9.93	AR 12.4
9.94-10.9	AR 13.6
11.0-12.4	AR 15.4
12.5-14.3	AR 17.6
14.4-15.8	AR 20.5
15.9-17.9	AR 23
18.0-20.0	AR 27
20.1-22.4	AR 30
22.5-25.0	AR 35

Table 36

Motor Full-Load Current (Amp)	Thermal Unit Number
90.6-97.4	AF 110
97.5-111.	AF 123
112.-129.	AF 135
130.-149.	AF 150
150.-163.	AF 159
164.-189.	AF 168
190-213.	AF 188
214.-240.	AF 205
241.-266.	AF 220

Table 39

Motor Full-Load Current (Amp)	Thermal Unit Number
148.-173.	AR 1.68
174.-189.	AR 1.85
190.-205.	AR 2.04
206.-222.	AR 2.24
223.-243.	AR 2.46
244.-261.	AR 2.71
262.-289.	AR 2.98
290.-324.	AR 3.28
325.-367.	AR 3.62
368.-389.	AR 3.98
390.-404.	AR 4.37
405.-451.	AR 4.80
452.-495.	AR 5.3
496.-520.	AR 5.8

Table 33

Motor Full-Load Current (Amp)	Thermal Unit Number
0.28-0.30	AR .45
0.31-0.33	AR .49
0.34-0.36	AR .54
0.37-0.39	AR .59
0.40-0.42	AR .65
0.52-0.56	AR .71
0.57-0.62	AR .78
0.63-0.68	AR .86
0.69-0.75	AR .95
0.76-0.83	AR 1.05
0.61-0.66	AR 1.15
0.67-0.73	AR 1.26
0.74-0.81	AR 1.39
0.82-0.90	AR 1.53
0.91-1.05	AR 1.68
1.06-1.15	AR 1.85
1.16-1.25	AR 2.04
1.26-1.35	AR 2.24
1.36-1.47	AR 2.46
1.48-1.58	AR 2.71
1.59-1.74	AR 2.98
1.75-1.94	AR 3.28
1.95-2.20	AR 3.62
2.21-2.47	AR 3.98
2.48-2.76	AR 4.37
2.77-3.07	AR 4.80
3.08-3.45	AR 5.3
3.46-3.81	AR 5.8
3.82-4.20	AR 6.4
4.21-4.65	AR 7.0
4.66-5.29	AR 7.7
5.30-5.84	AR 8.5
5.85-6.27	AR 9.3
6.28-6.97	AR 10.2
6.98-7.59	AR 11.2
7.60-7.89	AR 12.4
7.90-8.95	AR 13.6
8.96-10.3	AR 15.4
10.4-11.7	AR 17.6
11.8-12.0	AR 20.5

Following Selections for Size 1 Only

11.8-13.3	AR 20.5
13.4-15.2	AR 23
15.3-17.2	AR 27
17.3-19.7	AR 30
19.8-22.4	AR 35
22.5-26.0	AR 40

Table 40

Motor Full-Load Current (Amp)	Thermal Unit Number
15.3-16.7	C 20
16.8-19.8	C 22
19.9-22.8	C 26
22.9-25.8	C 30
25.9-30.4	C 34
30.5-31.9	C 40
32.0-34.2	C 42
34.3-38.8	C 45
38.9-44.2	C 51
44.3-50.2	C 58
50.3-57.1	C 66
57.2-63.2	C 75
63.3-68.6	C 83
68.7-78.6	C 90
78.7-86.0	C 103

Table 34

Motor Full-Load Current (Amp)	Thermal Unit Number
15.1-16.2	CC 20.9
16.3-17.5	CC 22.8
17.6-19.1	CC 24.6
19.2-20.7	CC 26.3
20.8-22.2	CC28.8
22.3-24.0	CC 31.0
24.1-25.7	CC 33.3
25.8-27.8	CC 36.4
27.9-30.1	CC 39.6
30.2-32.5	CC 42.7
32.6-35.1	CC 46.6
35.2-38.0	CC 50.1
38.1-41.1	CC 54.5
41.2-44.0	CC 59.4
44.1-47.2	CC 64.3
47.3-51.1	CC 68.5
51.2-55.8	CC 74.6
55.9-59.5	CC 81.5
59.6-64.5	CC 87.7
64.6-69.5	CC 94.0
69.6-75.0	CC 103
75.1-78.1	CC 112
78.2-82.3	CC 121
82.4-86.0	CC 132

Table 37

Motor Full-Load Current (Amp)	Thermal Unit Number
27.1-30.0	E 67
30.1-33.2	E 69
33.3-35.7	E 70
35.8-39.4	E 71
39.5-43.4	E 72
43.5-46.9	E 73
47.0-51.5	E 74
51.6-57.0	E 76
57.1-62.8	E 77
62.9-69.1	E 78
69.2-75.0	E 79
75.1-83.3	E 80

Table 41

Motor Full-Load Current (Amp)	Thermal Unit Number
0.81-0.92	B 1.16
0.93-1.07	B 1.30
1.08-1.14	B 1.45
1.15-1.26	B 1.67
1.27-1.49	B 1.88
1.50-1.73	B 2.10
1.74-1.89	B 2.40
1.90-2.16	B 2.65
2.17-2.37	B 3.00
2.38-2.66	B 3.30
2.67-2.99	B 3.70
3.00-3.40	B 4.15
3.41-3.94	B 4.85
3.95-4.15	B 5.50
4.16-4.49	B 6.25
4.50-5.15	B 6.90
5.16-5.77	B 7.70
5.78-6.61	B 8.20
6.62-7.14	B 9.10
7.15-7.97	B 10.2
7.98-8.15	B 11.5
8.15-9.32	B 12.8
9.33-9.97	B 14
9.98-10.7	B 15.5
10.8-12.0	B 17.5
12.1-13.9	B 19.5
14.0-15.7	B 22
15.8-18.4	B 25
18.5-21.6	B 28.0
21.7-24.0	B 32
24.1-28.6	B 36
28.7-30.7	B 40
30.8-33.5	B 45
33.6-36.0	B 56



Thermal Unit Selection

Tables 42 thru 52

Table 42

Motor Full-Load Current (Amp)	Thermal Unit Number
0.28-0.30	AR .45
0.31-0.33	AR .49
0.34-0.36	AR .54
0.37-0.39	AR .59
0.40-0.42	AR .65
0.43-0.46	AR .71
0.47-0.50	AR .78
0.51-0.52	AR .86
0.53-0.56	AR .95
0.57-0.60	AR 1.05
0.61-0.66	AR 1.15
0.67-0.73	AR 1.26
0.74-0.81	AR 1.39
0.82-0.90	AR 1.53
0.91-1.05	AR 1.68
1.06-1.15	AR 1.85
1.16-1.25	AR 2.04
1.26-1.35	AR 2.24
1.36-1.47	AR 2.46
1.48-1.58	AR 2.71
1.59-1.74	AR 2.98
1.75-1.94	AR 3.28
1.95-2.20	AR 3.62
2.21-2.47	AR 3.98
2.48-2.76	AR 4.37
2.77-3.07	AR 4.80
3.08-3.45	AR 5.3
3.46-3.81	AR 5.8
3.82-4.20	AR 6.4
4.21-4.65	AR 7.0
4.66-5.29	AR 7.7
5.30-5.84	AR 8.5
5.85-6.27	AR 9.3
6.28-6.97	AR 10.2
6.98-7.59	AR 11.2
7.60-7.89	AR 12.4
7.90-8.95	AR 13.6
8.96-10.3	AR 15.4
10.4-11.7	AR 17.6
11.8-13.3	AR 20.5
13.4-15.2	AR 23
15.3-17.2	AR 27
17.3-19.7	AR 30
19.8-22.4	AR 35
22.5-26.0	AR 40

Table 43

Motor Full-Load Current (Amp)	Thermal Unit Number
0.41-0.44	A .49
0.45-0.49	A .54
0.50-0.53	A .59
0.54-0.58	A .65
0.59-0.65	A .71
0.66-0.71	A .78
0.72-0.78	A .86
0.79-0.85	A .95
0.86-0.96	A 1.02
0.97-1.04	A 1.16
1.05-1.16	A 1.25
1.17-1.29	A 1.39
1.30-1.37	A 1.54
1.38-1.47	A 1.63
1.48-1.56	A 1.75
1.57-1.65	A 1.86
1.66-1.79	A 1.99
1.80-1.95	A 2.15
1.96-2.15	A 2.31
2.16-2.38	A 2.57
2.39-2.75	A 2.81
2.76-2.84	A 3.61
2.85-3.06	A 3.95
3.07-3.45	A 4.32
3.46-3.70	A 4.79
3.71-4.07	A 5.30
4.08-4.32	A 5.78
4.33-4.90	A 6.20
4.91-5.35	A 6.99
5.36-5.85	A 7.65
5.86-6.41	A 8.38
6.42-6.79	A 9.25
6.80-7.57	A 9.85
7.58-8.15	A 11.0
8.16-8.98	A 11.9
8.99-9.67	A 13.2
9.68-9.95	A 14.1
9.96-10.8	A 14.8
10.9-12.1	A 16.2
12.2-13.1	A 17.9
13.2-13.9	A 19.8
14.0-15.0	A 21.3
15.1-16.0	A 25.2

Table 44

Motor Full-Load Current (Amp)	Thermal Unit Number
0.34-0.38	B 0.44
0.39-0.43	B 0.51
0.44-0.48	B 0.57
0.49-0.53	B 0.65
0.54-0.62	B 0.71
0.63-0.69	B 0.81
0.70-0.78	B 0.92
0.79-0.88	B 1.03
0.89-0.99	B 1.16
1.00-1.10	B 1.30
1.11-1.26	B 1.45
1.27-1.43	B 1.67
1.44-1.59	B 1.88
1.60-1.81	B 2.10
1.82-2.00	B 2.40
2.01-2.28	B 2.65
2.29-2.52	B 3.00
2.53-2.87	B 3.30
2.88-3.28	B 3.70
3.29-3.75	B 4.15
3.76-4.27	B 4.85
4.28-4.77	B 5.50
4.78-5.27	B 6.25
5.28-5.91	B 6.90
5.92-6.25	B 7.70
6.26-6.83	B 8.20
6.84-7.65	B 9.10
7.66-8.55	B 10.2
8.56-9.56	B 11.5
9.57-10.3	B 12.8
10.4-11.3	B 14
11.4-12.4	B 15.5
12.5-14.1	B 17.5
14.2-15.7	B 19.5
15.8-17.9	B 22
18.0-20.1	B 25
20.2-22.5	B 28.0
22.6-25.0	B 32

Table 45

Size 7	Size 8	Thermal Unit Number
Type J	Type K	
Current Transformer		
Ratio		
1200/5	2000/5	
Motor Full-Load Current		
Non-Compensated		
136.-150.	227.-251.	AR 1.05
151.-165.	252.-276.	AR 1.15
166.-183.	277.-305.	AR 1.26
184.-202.	306.-337.	AR 1.39
203.-224.	338.-373.	AR 1.53
225.-267.	374.-445.	AR 1.68
268.-293.	446.-489.	AR 1.85
294.-319.	490.-532.	AR 2.04
320.-349.	533.-582.	AR 2.24
350.-381.	583.-636.	AR 2.46
382.-418.	637.-697.	AR 2.71
419.-459.	698.-766.	AR 2.98
460.-509.	767.-849.	AR 3.28
510.-565.	850.-942.	AR 3.62
566.-604.	943.-1007.	AR 3.98
605.-697.	1008.-1133.	AR 4.37
698.-753.	AR 4.80
Compensated		
161.-177.	268.-295.	AR 1.26
178.-196.	296.-327.	AR 1.39
197.-217.	328.-363.	AR 1.53
218.-253.	364.-423.	AR 1.68
254.-277.	424.-463.	AR 1.85
278.-301.	464.-503.	AR 2.04
302.-325.	504.-543.	AR 2.24
326.-354.	544.-592.	AR 2.46
355.-381.	592.-635.	AR 2.71
382.-419.	636.-699.	AR 2.98
420.-467.	700.-779.	AR 3.28
468.-529.	780.-883.	AR 3.62
530.-594.	884.-991.	AR 3.98
595.-664.	992.-1107.	AR 4.37
665.-738.	1108.-1231.	AR 4.80
739.-829.	AR 5.3

Table 46

Motor Full-Load Current (Amp)	Thermal Unit Number
105.-116.	AR 3.28
117.-132.	AR 3.62
133.-148.	AR 3.98
149.-165.	AR 4.37
166.-184.	AR 4.80
185.-207.	AR 5.3
208.-229.	AR 5.8
230.-266.	AR 6.4

Table 47

Motor Full-Load Current (Amp)	Thermal Unit Number
146.-169.	AR 1.68
170.-185.	AR 1.85
186.-201.	AR 2.04
202.-217.	AR 2.24
218.-236.	AR 2.46
237.-253.	AR 2.71
254.-279.	AR 2.98
280.-311.	AR 3.28
312.-353.	AR 3.62
354.-396.	AR 3.98
397.-442.	AR 4.37
443.-492.	AR 4.80
493.-520.	AR 5.3

Table 48

Motor Full-Load Current (Amp)	Thermal Unit Number
158.-187.	AR 1.68
188.-206.	AR 1.85
207.-224.	AR 2.04
225.-244.	AR 2.24
245.-267.	AR 2.46
268.-289.	AR 2.71
290.-324.	AR 2.98
325.-361.	AR 3.28
362.-406.	AR 3.62
407.-445.	AR 3.98
446.-463.	AR 4.37
464.-520.	AR 4.80

Table 49

Motor Full-Load Current (Amp)	Thermal Unit Number
82.5-88.2	DD 112
88.3-95.9	DD 121
96.0-102.	DD 128
103.-109.	DD 140
110.-121.	DD 150
122.-139.	DD 160
140.-154.	DD 185
155.-163.	DD 220
164.-175.	DD 240
176.-184.	DD 250
185.-195.	DD 265
196.-215.	DD 280
216.-224.	DD 300
225.-243.	DD 320
244.-266.	DD 340

Table 50

Motor Full-Load Current (Amp)	Thermal Unit Number
14.4-16.1	AU 20
16.2-18.6	AU 23
18.7-20.5	AU 26
20.6-23.4	AU 29
23.5-26.9	AU 33
27.0-28.3	AU 38
28.4-30.8	AU 40
30.9-35.0	AU 44
35.1-38.8	AU 50
38.9-44.3	AU 56
44.4-49.3	AU 64
49.4-55.5	AU 72
55.6-61.0	AU 81
61.1-68.6	AU 88
68.7-76.3	AU 99
76.4-86.0	AU 110

Table 51

Motor Full-Load Current (Amp)	Thermal Unit Number
15.7-17.7	AU 20
17.8-19.9	AU 23
20.0-22.7	AU 26
22.8-25.7	AU 29
25.8-29.1	AU 33
29.2-30.8	AU 38
30.9-34.3	AU 40
34.4-38.3	AU 44
38.4-42.3	AU 50
42.4-47.5	AU 56
47.6-53.0	AU 64
53.1-60.5	AU 72
60.6-64.9	AU 81
65.0-71.5	AU 88
71.6-77.3	AU 99
77.4-86.0	AU 110

Table 52

Motor Full-Load Current (Amp)	Thermal Unit Number
92.0-103.	AF 123
104.-116.	AF 135
117.-139.	AF 150
140.-150.	AF 159
151.-167.	AF 168
168.-177.	AF 188
178.-205.	AF 205
206.-222.	AF 220
223.-232.	AF 240
233.-247.	AF 260
248.-266.	AF 308



Thermal Unit Selection Tables 53 thru 63

Table 53

Motor Full-Load Current (Amp)		Thermal Unit Number
1 T. U.	3 T. U.	
0.31-0.33	0.29-0.31	B 0.44
0.34-0.36	0.32-0.36	B 0.51
0.37-0.40	0.37-0.38	B 0.57
0.41-0.48	0.39-0.46	B 0.63
0.49-0.57	0.47-0.55	B 0.71
0.58-0.64	0.56-0.61	B 0.81
0.65-0.70	0.62-0.66	B 0.92
0.71-0.77	0.67-0.75	B 1.03
0.78-0.85	0.76-0.83	B 1.16
0.86-0.99	0.84-0.93	B 1.30
1.00-1.10	0.94-1.06	B 1.45
1.11-1.28	1.07-1.18	B 1.67
1.29-1.14	1.19-1.31	B 1.88
1.42-1.58	1.32-1.47	B 2.10
1.59-1.80	1.48-1.67	B 2.40
1.81-2.03	1.68-1.83	B 2.65
2.04-2.25	1.84-2.04	B 3.00
2.26-2.51	2.05-2.38	B 3.30
2.52-2.83	2.39-2.60	B 3.70
2.84-3.29	2.61-3.13	B 4.15
3.30-3.75	3.14-3.59	B 4.85
3.76-4.22	3.60-3.94	B 5.50
4.23-4.65	3.95-4.19	B 6.25
4.66-5.16	4.20-4.72	B 6.90
5.17-5.53	4.73-5.21	B 7.70
5.54-6.09	5.22-5.51	B 8.20
6.10-6.80	5.52-6.17	B 9.10
6.81-7.60	6.18-7.00	B 10.2
7.61-8.35	B 11.5
8.36-9.00	B 12.8

Table 57

Motor Full-Load Current (Amp)		Thermal Unit Number
2 T. U.	3 T. U.	
5.09-5.59	5.15-5.97	AR 8.5
5.60-6.11	5.98-6.50	AR 9.3
6.12-6.72	6.51-7.04	AR 10.2
6.73-7.37	7.05-7.59	AR 11.2
7.38-7.67	7.60-7.93	AR 12.4
7.68-8.68	7.94-9.04	AR 13.6
8.69-9.94	9.05-10.2	AR 15.4
9.95-11.1	10.3-11.5	AR 17.6
11.2-12.9	11.6-13.2	AR 20.5
13.0-14.7	13.3-14.9	AR 23
14.8-16.9	15.0-16.9	AR 27
17.0-19.2	17.0-19.3	AR 30
19.3-21.9	19.4-21.7	AR 35
22.0-24.4	21.8-25.0	AR 40
24.5-26.3	25.1-27.0	AR 44
26.4-28.0	27.1-29.1	AR 47
28.1-30.3	29.2-30.8	AR 51
30.4-32.2	30.9-32.9	AR 55
32.3-34.4	33.0-35.0	AR 60
34.5-36.6	35.1-37.1	AR 66
36.7-39.5	37.2-39.1	AR 72
39.6-45.0	39.2-41.5	AR 79
.....	41.6-45.0	AR 86

Table 61

Motor Full-Load Current (Amp)		Thermal Unit Number
2 T. U.	3 T. U.	
46.8-50.0	45.3-48.2	CC 64.3
50.1-54.2	48.3-52.4	CC 68.5
54.3-58.3	52.5-56.4	CC 74.6
58.4-63.6	56.5-61.2	CC 81.5
63.7-68.5	61.3-66.1	CC 87.7
68.6-74.0	66.2-71.4	CC 94.0
74.1-79.8	71.5-77.0	CC 103
79.9-83.0	77.1-79.0	CC 112
83.1-88.9	79.1-84.7	CC 121
89.0-95.6	84.8-91.1	CC 132
95.7-102.	91.2-98.1	CC 143
103.-109.	98.2-104.	CC 156
110.-119.	105.-113.	CC 167
120.-133.	114.-123.	CC 180
.....	124.-133.	CC 196

Table 54

Motor Full-Load Current (Amp)		Thermal Unit Number
2 T. U.	3 T. U.	
43.6-45.5	41.1-43.5	CC 64.3
45.6-49.6	43.6-46.8	CC 68.5
49.7-53.1	46.9-50.0	CC 74.6
53.2-57.6	50.1-54.9	CC 81.5
57.7-62.4	55.0-57.5	CC 87.7
62.5-67.5	57.6-61.8	CC 94.0
67.6-71.1	61.9-66.2	CC 103
71.2-75.9	66.3-72.4	CC 112
76.0-81.9	72.5-78.1	CC 121
82.0-84.6	78.2-80.7	CC 132
84.7-90.7	80.8-86.5	CC 143
90.8-98.4	86.6-93.9	CC 156
98.5-105.	94.0-100.	CC 167
106.-117.	101.-112.	CC 180
118.-123.	113.-117.	CC 196
124.-133.	118.-123.	CC 208
.....	124.-133.	CC 219

Table 58

Motor Full-Load Current (Amp)		Thermal Unit Number
1 or 2 T. U.	3 T. U.	
3.37-3.82	3.28-3.51	B 4.85
3.83-4.33	3.52-3.89	B 5.50
4.34-4.79	3.90-4.14	B 6.25
4.80-5.33	4.15-4.73	B 6.90
5.34-5.79	4.74-5.22	B 7.70
5.80-6.27	5.23-5.53	B 8.20
6.28-7.03	5.54-6.21	B 9.10
7.04-7.88	6.22-7.17	B 10.2
7.89-8.73	7.18-8.19	B 11.5
8.74-9.55	8.20-8.90	B 12.8
9.56-10.6	8.91-9.57	B 14
10.7-11.8	9.58-10.6	B 15.5
11.9-13.1	10.7-11.8	B 17.5
13.2-14.9	11.9-12.7	B 19.5
15.0-16.9	12.8-14.4	B 22
17.0-18.8	14.5-16.1	B 25
18.9-21.5	16.2-18.2	B 28.0
21.6-24.1	18.3-20.2	B 32
24.2-26.8	20.3-22.8	B 36
26.9-29.9	22.9-25.6	B 40
30.0-35.5	25.7-28.8	B 45
35.6-36.5	28.9-30.6	B 50
36.6-39.6	30.7-32.4	B 56
39.7-41.5	32.5-34.6	B 62
41.6-45.0	34.7-38.6	B 70
.....	38.7-45.0	B 79

Table 62

Motor Full-Load Current (Amp)		Thermal Unit Number
2 T. U.	3 T. U.	
4.83-5.33	4.90-5.68	AR 8.5
5.34-5.84	5.69-6.19	AR 9.3
5.85-6.43	6.20-6.71	AR 10.2
6.44-7.03	6.72-7.14	AR 11.2
7.04-7.30	7.15-7.49	AR 12.4
7.31-8.29	7.50-8.48	AR 13.6
8.30-9.49	8.49-9.66	AR 15.4
9.50-10.7	9.67-10.8	AR 17.6
10.8-12.3	10.9-12.4	AR 20.5
12.4-14.0	12.5-13.9	AR 23
14.1-16.0	14.0-15.7	AR 27
16.1-18.4	15.8-18.1	AR 30
18.5-21.0	18.2-20.3	AR 35
21.1-23.0	20.4-23.0	AR 40
23.1-25.5	23.1-25.2	AR 44
25.6-26.7	25.3-26.6	AR 47
26.8-28.3	26.7-28.2	AR 51
28.4-30.3	28.3-30.2	AR 55
30.4-32.5	30.3-32.3	AR 60
32.6-34.5	32.4-34.3	AR 66
34.6-37.6	34.4-36.7	AR 72
37.7-39.7	36.8-36.3	AR 79
39.8-41.4	39.4-45.0	AR 86
41.5-45.0	AR 94

Table 55

Motor Load-Full Current (Amp)		Thermal Unit Number
2 T. U.	3 T. U.	
0.38-0.40	0.31-0.33	AR 45
0.41-0.43	0.34-0.36	AR 49
0.44-0.48	0.37-0.39	AR 54
0.49-0.52	0.40-0.43	AR 59
0.53-0.56	0.44-0.47	AR 65
0.57-0.61	0.48-0.51	AR 71
0.62-0.67	0.52-0.56	AR 78
0.68-0.73	0.57-0.58	AR 86
0.74-0.81	0.59-0.64	AR 95
0.82-0.89	0.65-0.70	AR 1.05
0.90-0.97	0.71-0.77	AR 1.15
0.98-1.07	0.78-0.85	AR 1.26
1.08-1.17	0.86-0.94	AR 1.39
1.18-1.31	0.95-1.03	AR 1.53
1.32-1.49	1.04-1.22	AR 1.68
1.50-1.69	1.23-1.34	AR 1.85
1.70-1.83	1.35-1.46	AR 2.04
1.84-2.00	1.47-1.58	AR 2.24
2.01-2.17	1.59-1.76	AR 2.46
2.18-2.35	1.77-1.85	AR 2.71
2.36-2.60	1.86-2.08	AR 2.98
2.61-2.87	2.09-2.27	AR 3.28
2.88-3.14	2.28-2.51	AR 3.62
3.15-3.47	2.52-2.90	AR 3.98
3.48-3.90	2.91-3.23	AR 4.37
3.91-4.36	3.24-3.58	AR 4.80
4.37-4.88	3.59-4.02	AR 5.3
4.89-5.37	4.03-4.43	AR 5.8
5.38-5.97	4.44-4.86	AR 6.4
5.98-6.55	4.87-5.37	AR 7.0
6.56-7.50	5.38-6.12	AR 7.7
7.51-8.23	6.13-6.65	AR 8.5
8.24-9.00	6.66-7.00	AR 9.3

Table 59

Motor Full-Load Current (Amp)		Thermal Unit Number
1 or 2 T. U.	3 T. U.	
0.34-0.38	0.29-0.31	B 0.44
0.39-0.43	0.32-0.35	B 0.51
0.44-0.47	0.36-0.38	B 0.57
0.48-0.53	0.39-0.46	B 0.63
0.54-0.60	0.47-0.55	B 0.71
0.61-0.68	0.56-0.62	B 0.81
0.69-0.76	0.63-0.67	B 0.92
0.77-0.86	0.68-0.75	B 1.03
0.87-0.97	0.76-0.84	B 1.16
0.98-1.07	0.85-0.95	B 1.30
1.08-1.23	0.96-1.09	B 1.45
1.24-1.39	1.10-1.21	B 1.67
1.40-1.55	1.22-1.35	B 1.88
1.56-1.77	1.36-1.53	B 2.10
1.78-1.96	1.54-1.73	B 2.40
1.97-2.15	1.74-1.90	B 2.65
2.16-2.41	1.91-2.14	B 3.00
2.42-2.71	2.15-2.34	B 3.30
2.72-3.03	2.35-2.67	B 3.70
3.04-3.53	2.68-3.22	B 4.15
3.54-4.01	3.23-3.48	B 4.85
4.02-4.56	3.49-3.87	B 5.50
4.57-5.03	3.88-4.14	B 6.25
5.04-5.59	4.15-4.73	B 6.90
5.60-5.95	4.74-5.28	B 7.70
5.96-6.58	5.29-5.64	B 8.20
6.59-7.31	5.65-6.39	B 9.10
7.32-8.15	6.40-7.43	B 10.2
8.16-9.13	7.44-8.55	B 11.5
9.14-9.91	8.56-9.40	B 12.8
9.92-10.7	9.41-10.0	B 14
10.8-12.1	10.1-11.2	B 15.5
12.2-13.5	11.3-12.5	B 17.5
13.6-15.1	12.6-13.5	B 19.5
15.2-17.0	13.6-15.4	B 22
17.1-18.9	15.5-17.5	B 25
19.0-21.5	17.6-19.9	B 28.0
21.6-24.0	20.0-22.2	B 32
24.1-26.0	22.3-25.5	B 36
.....	25.6-26.0	B 40

Table 56

Motor Full-Load Current (Amp)		Thermal Unit Number
1 or 2 T. U.	3 T. U.	
3.29-3.74	3.18-3.40	B 4.85
3.75-4.23	3.41-3.76	B 5.50
4.24-4.68	3.77-4.00	B 6.25
4.69-5.22	4.01-4.57	B 6.90
5.23-5.67	4.58-5.03	B 7.70
5.68-6.13	5.04-5.32	B 8.20
6.14-6.91	5.33-5.97	B 9.10
6.92-7.70	5.98-6.88	B 10.2
7.71-8.56	6.89-7.82	B 11.5
8.57-9.39	7.83-8.47	B 12.8
9.40-10.4	8.48-9.15	B 14
10.5-11.6	9.16-10.1	B 15.5
11.7-12.9	10.2-11.2	B 17.5
13.0-14.6	11.3-12.0	B 19.5
12.1-13.6	12.1-13.6	B 22
16.6-18.5	13.7-15.2	B 25
18.6-21.0	15.3-17.1	B 28.0
21.1-23.6	17.2-19.0	B 32
23.7-26.3	19.1-21.5	B 36
26.4-29.3	21.6-24.1	B 40
29.4-35.1	24.2-27.0	B 45
35.2-36.1	27.1-28.7	B 50
36.2-39.1	28.8-30.4	B 56
39.2-41.5	30.5-32.2	B 62
41.6-45.0	32.3-35.4	B 70
.....	35.5-38.2	B 79
.....	38.3-45.0	B 88

Table 60

Motor Full-Load Current (Amp)	Thermal Unit Number
6.84-7.49	AR 9.3
7.50-8.05	AR 10.2
8.06-9.10	AR 11.2
9.11-9.99	AR 12.4
10.0-11.1	AR 13.6
11.2-12.7	AR 15.4
12.8-14.8	AR 17.6
14.9-16.6	AR 20.5
16.7-19.3	AR 23
19.4-21.4	AR 27
21.5-25.1	AR 30
25.2-28.3	AR 35
28.4-31.2	AR 40
31.3-33.3	AR 44
33.4-35.7	AR 47
35.8-38.5	AR 51
38.6-41.5	AR 55
41.6-45.0	AR 60

Table 63

Motor Full-Load Current (Amp)	Thermal Unit Number
15.1-17.0	AU 20
17.1-19.1	AU 23
19.2-21.8	AU 26
21.9-24.5	AU 29
24.6-27.9	

Thermal Unit Selection

Tables 64 thru 71

Table 64

Motor Full-Load Current (Amp.)			Thermal Unit Number
2 T. U. 1 PH	2 T. U. 2 PH	3 T. U.	
0.38-0.40	0.38-0.40	0.31-0.33	AR .45
0.41-0.43	0.41-0.43	0.34-0.36	AR .49
0.44-0.48	0.44-0.48	0.37-0.39	AR .54
0.49-0.52	0.49-0.52	0.40-0.43	AR .59
0.53-0.56	0.53-0.56	0.44-0.47	AR .65
0.57-0.61	0.57-0.61	0.48-0.51	AR .71
0.62-0.67	0.62-0.67	0.52-0.56	AR .78
0.68-0.73	0.68-0.73	0.57-0.58	AR .86
0.74-0.81	0.74-0.81	0.59-0.64	AR .95
0.82-0.89	0.82-0.89	0.65-0.70	AR 1.05
0.90-0.97	0.90-0.97	0.71-0.77	AR 1.15
0.98-1.07	0.98-1.07	0.78-0.85	AR 1.26
1.08-1.17	1.08-1.17	0.86-0.94	AR 1.39
1.18-1.31	1.18-1.31	0.95-1.03	AR 1.53
1.32-1.49	1.32-1.49	1.04-1.22	AR 1.68
1.50-1.69	1.50-1.69	1.23-1.34	AR 1.85
1.70-1.83	1.70-1.83	1.35-1.46	AR 2.04
1.84-2.00	1.84-2.00	1.47-1.58	AR 2.24
2.01-2.17	2.01-2.17	1.59-1.76	AR 2.46
2.18-2.35	2.18-2.35	1.77-1.85	AR 2.71
2.36-2.60	2.36-2.60	1.86-2.08	AR 2.98
2.61-2.87	2.61-2.87	2.09-2.27	AR 3.28
2.88-3.14	2.88-3.14	2.28-2.51	AR 3.62
3.15-3.47	3.15-3.47	2.52-2.90	AR 3.98
3.48-3.90	3.48-3.90	2.91-3.23	AR 4.37
3.91-4.36	3.91-4.36	3.24-3.58	AR 4.80
4.37-4.88	4.37-4.88	3.59-4.02	AR 5.3
4.89-5.37	4.89-5.37	4.03-4.43	AR 5.8
5.38-5.97	5.38-5.97	4.44-4.86	AR 6.4
5.98-6.55	5.98-6.55	4.87-5.37	AR 7.0
6.56-7.50	6.56-7.50	5.38-6.12	AR 7.7
7.51-8.23	7.51-8.23	6.13-6.65	AR 8.5
8.24-8.99	8.24-8.99	6.66-7.31	AR 9.3
9.00-9.86	9.00-9.86	7.32-7.96	AR 10.2
9.87-10.7	9.87-10.7	7.97-8.69	AR 11.2
10.8-11.2	10.8-11.2	8.70-8.99	AR 12.4
11.3-12.8	11.3-12.0	9.00-10.1	AR 13.6
12.9-14.8	10.2-11.5	AR 15.4
14.9-16.7	11.6-12.0	AR 17.6
16.8-18.0	AR 20.5
Following Selections for Size 1 Only.			
....	11.3-12.8	AR 13.6
....	12.9-14.8	AR 15.4
....	14.9-16.7	11.6-13.0	AR 17.6
16.8-19.0	16.8-19.0	13.1-14.6	AR 20.5
19.1-22.0	19.1-22.0	14.7-16.5	AR 23
22.1-24.9	22.1-24.9	16.6-18.5	AR 27
25.0-26.0	25.0-26.0	18.6-21.0	AR 30
....	21.1-23.6	AR 35
....	23.7-26.0	AR 40

Table 65

Motor Full-Load Current (Amp)	Thermal Unit Number
0.31-0.35	B 0.44
0.36-0.39	B 0.51
0.40-0.44	B 0.57
0.45-0.50	B 0.63
0.51-0.58	B 0.71
0.59-0.65	B 0.81
0.66-0.73	B 0.92
0.74-0.82	B 1.03
0.83-0.92	B 1.16
0.93-1.03	B 1.30
1.04-1.19	B 1.45
1.20-1.34	B 1.67
1.35-1.50	B 1.88
1.51-1.67	B 2.10
1.68-1.89	B 2.40
1.90-2.14	B 2.65
2.15-2.36	B 3.00
2.37-2.65	B 3.30
2.66-2.97	B 3.70
2.98-3.47	B 4.15
3.48-3.94	B 4.85
3.95-4.44	B 5.50
4.45-4.94	B 6.25
4.95-5.52	B 6.90
5.53-5.88	B 7.70
5.89-6.52	B 8.20
6.53-7.31	B 9.10
7.32-8.21	B 10.2
8.22-9.18	B 11.5
9.19-9.90	B 12.8
10.0-11.0	B 14
11.1-12.4	B 15.5
12.5-13.9	B 17.5
14.0-15.7	B 19.5
15.8-17.8	B 22
17.9-20.0	B 25
20.1-22.9	B 28.0
23.0-25.0	B 32
Following Selections for Size 2 Only.	
23.0-25.7	B 32
25.8-28.6	B 36
28.7-32.2	B 40
32.3-35.8	B 45
35.9-40.1	B 50
40.2-44.4	B 56
44.5-50.0	B 62

Table 66

Motor Full-Load Current (Amp)	Thermal Unit Number
0.31-0.32	B 0.44
0.33-0.36	B 0.51
0.37-0.41	B 0.57
0.42-0.49	B 0.63
0.50-0.54	B 0.71
0.55-0.61	B 0.81
0.62-0.67	B 0.92
0.68-0.76	B 1.03
0.77-0.87	B 1.16
0.88-0.98	B 1.30
0.99-1.05	B 1.45
1.06-1.25	B 1.67
1.26-1.33	B 1.88
1.34-1.56	B 2.10
1.57-1.71	B 2.40
1.72-1.97	B 2.65
1.98-2.15	B 3.00
2.16-2.42	B 3.30
2.43-2.78	B 3.70
2.79-3.28	B 4.15
3.29-3.88	B 4.85
3.89-4.13	B 5.5
4.14-4.43	B 6.25
4.44-4.96	B 6.90
4.97-5.35	B 7.70
5.36-5.91	B 8.20
5.92-6.79	B 9.10
6.80-7.56	B 10.2
7.57-7.83	B 11.5
7.84-8.09	B 12.8
8.10-9.51	B 14
9.52-10.1	B 15.5
10.2-11.3	B 17.5
11.4-13.1	B 19.5
13.2-14.9	B 22
15.0-16.1	B 25
16.2-17.8	B 28.0
17.9-19.1	B 32
19.2-22.4	B 36
22.5-23.5	B 40
23.6-26.0	B 45

Table 67

Motor Full-Load Current (Amp)	Thermal Unit Number
3.79-4.14	B 5.50
4.15-4.44	B 6.25
4.45-5.22	B 6.90
5.23-5.29	B 7.70
5.30-5.99	B 8.20
6.00-6.82	B 9.10
6.83-7.68	B 10.2
7.69-7.92	B 11.5
7.93-8.47	B 12.8
8.48-9.99	B 14
10.0-10.8	B 15.5
10.9-12.3	B 17.5
12.4-12.9	B 19.5
13.0-15.1	B 22
15.2-16.7	B 25
16.8-17.9	B 28.0
18.0-20.1	B 32
20.2-23.8	B 36
23.9-25.8	B 40
25.9-28.3	B 45
28.4-29.6	B 50
29.7-32.1	B 56
32.2-34.4	B 62
34.5-38.3	B 70
38.4-39.9	B 79
40.0-45.0	B 88

Table 68

Motor Full-Load Current (Amp)	Thermal Unit Number
14.9-16.1	CC 20.9
16.2-17.3	CC 22.8
17.4-19.5	CC 24.6
19.6-20.7	CC 26.3
20.8-22.4	CC 28.8
22.5-23.9	CC 31.0
24.0-25.8	CC 33.3
25.9-27.6	CC 36.4
27.7-29.7	CC 39.6
29.8-31.8	CC 42.7
31.9-34.2	CC 46.6
34.3-37.0	CC 50.1
37.1-39.6	CC 54.5
39.7-42.5	CC 59.4
42.6-45.0	CC 64.3
45.1-48.6	CC 68.5
48.7-51.2	CC 74.6
51.3-56.0	CC 81.5
56.1-60.1	CC 87.7
60.2-64.3	CC 94.0
64.4-68.9	CC 103
69.0-71.9	CC 112
72.0-75.4	CC 121
75.5-78.9	CC 132
79.0-82.1	CC 143
82.2-86.0	CC 156

Table 69

Motor Full-Load Current (Amp)	Thermal Unit Number	
1 or 2 T. U.	3 T. U.	
3.46-3.90	3.38-3.65	B 4.85
3.91-4.44	3.66-4.07	B 5.50
4.45-4.91	4.08-4.36	B 6.25
4.92-5.51	4.37-5.19	B 6.90
5.52-5.84	5.20-5.59	B 7.70
5.85-6.54	5.60-5.98	B 8.20
6.55-7.33	5.99-6.78	B 9.10
7.34-8.31	6.79-7.91	B 10.2
8.32-9.22	7.92-9.12	B 11.5
9.23-10.0	9.13-10.0	B 12.8
10.1-11.2	10.1-10.7	B 14
11.3-12.5	10.8-12.0	B 15.5
12.6-14.2	12.1-13.5	B 17.5
14.3-16.1	13.6-14.6	B 19.5
16.2-18.4	14.7-16.7	B 22
18.5-20.5	16.8-18.9	B 25
20.6-23.2	19.0-21.6	B 28.0
23.3-26.6	21.7-24.1	B 32
26.7-29.6	24.2-27.6	B 36
29.7-33.5	27.7-31.2	B 40
33.6-37.2	31.3-35.5	B 45
37.3-41.5	35.6-37.8	B 50
41.6-45.0	37.9-41.5	B 56
....	41.6-45.0	B 62

Table 70

Motor Full-Load Current (Amp)	Thermal Unit Number
4.24-4.62	AR 8.5
4.63-5.05	AR 9.3
5.06-5.54	AR 10.2
5.55-6.13	AR 11.2
6.14-6.44	AR 12.4
6.45-7.48	AR 13.6
7.49-8.55	AR 15.4
8.56-9.74	AR 17.6
9.75-11.1	AR 20.5
11.2-12.7	AR 23
12.8-14.4	AR 27
14.5-16.4	AR 30
16.5-18.9	AR 35
19.0-21.6	AR 40
21.7-23.3	AR 44
23.4-24.9	AR 47
25.0-26.9	AR 51
27.0-29.1	AR 55
29.2-31.3	AR 60
31.4-33.5	AR 66
33.6-36.9	AR 72
37.0-39.1	AR 79
39.2-40.9	AR 86
41.0-45.0	AR 94

Table 71

Motor Full-Load Current (Amp)	Thermal Unit Number
3.98-4.53	AR 8.5
4.54-5.03	AR 9.3
5.04-5.46	AR 10.2
5.47-6.01	AR 11.2
6.02-6.31	AR 12.4
6.32-7.19	AR 13.6
7.20-8.29	AR 15.4
8.30-9.49	AR 17.6
9.50-11.0	AR 20.5
11.1-12.6	AR 23
12.7-14.3	AR 27
14.4-16.5	AR 30
16.6-19.2	AR 35
19.3-21.9	AR 40
22.0-23.8	AR 44
23.9-25.5	AR 47
25.6-27.7	AR 51
27.8-30.1	AR 55
30.2-32.5	AR 60
32.6-34.8	AR 66
34.9-38.5	AR 72
38.6-41.5	AR 79
41.6-45.0	AR 86



Thermal Unit Selection Tables 72 thru 77

Table 72

Motor Full-Load Current (Amp)		Thermal Unit Number
1 T. U.	3 T. U.	
2.38-2.62	2.38-2.62	FB 3.33
2.63-2.94	2.63-2.94	FB 3.71
2.95-3.31	2.95-3.31	FB 4.1
3.32-3.43	3.32-3.43	FB 4.5
3.44-3.81	3.44-3.81	FB 4.75
3.82-4.32	3.82-4.32	FB 5.3
4.33-4.75	4.33-4.75	FB 6.1
4.76-5.38	4.76-5.38	FB 6.75
5.39-5.75	5.39-5.75	FB 7.45
5.76-5.97	5.76-5.97	FB 7.8
5.98-6.30	5.98-6.30	FB 8.21
6.31-6.55	6.31-6.55	FB 8.6
6.56-6.89	6.56-6.89	FB 9.0
6.90-7.14	6.90-7.14	FB 9.5
7.15-7.36	7.15-7.36	FB 10
7.37-8.30	7.37-8.30	FB 10.6
8.31-8.59	8.31-8.59	FB 11.2
8.60-9.01	8.60-9.01	FB 12.1
9.02-9.68	9.02-9.68	FB 13.1
9.69-9.99	9.69-9.99	FB 13.9
10.0-10.9	10.0-10.9	FB 14.8
11.0-11.3	11.0-11.3	FB 15.6
11.4-12.4	11.4-12.0	FB 16.4
12.5-12.9	FB 17.6
13.0-14.0	FB 18.4
14.1-14.5	FB 19.4
14.6-15.7	FB 21.1
15.8-16.6	FB 22.6
16.7-18.0	FB 23.6
Following Selections for Size M-1 & M-1P Only.		
....	11.4-12.4	FB 16.4
....	12.5-12.9	FB 17.6
....	13.0-14.0	FB 18.4
....	14.1-14.5	FB 19.4
....	14.6-15.7	FB 21.1
....	15.8-16.6	FB 22.6
16.7-17.6	16.7-17.6	FB 23.6
17.7-18.3	17.7-18.3	FB 24.8
18.4-19.4	18.4-19.4	FB 26.7
19.5-20.5	19.5-20.5	FB 28.3
20.6-21.7	20.6-21.7	FB 29.6
21.8-22.8	21.8-22.8	FB 30.5
22.9-24.3	22.9-24.3	FB 32.5
24.4-24.7	24.4-24.7	FB 34.1
24.8-25.4	24.8-25.4	FB 35
25.5-26.0	25.5-26.0	FB 36.6
Following Selections for Size M-1P Only.		
26.1-27.7	FB 38.3
27.8-28.9	FB 40.2
29.0-30.6	FB 42
30.7-32.5	FB 44
32.6-36.0	FB 46

Table 73

Motor Full-Load Current (Amp)		Thermal Unit Number
1 T. U.	3 T. U.	
2.42-2.67	2.42-2.67	FB 3.33
2.68-3.00	2.68-3.00	FB 3.71
3.01-3.36	3.01-3.36	FB 4.1
3.37-3.53	3.37-3.53	FB 4.5
3.54-3.91	3.54-3.91	FB 4.75
3.92-4.41	3.92-4.41	FB 5.3
4.42-4.83	4.42-4.83	FB 6.1
4.84-5.45	4.84-5.45	FB 6.75
5.46-5.89	5.46-5.89	FB 7.45
5.90-6.04	5.90-6.04	FB 7.8
6.05-6.55	6.05-6.55	FB 8.21
6.56-6.72	6.56-6.72	FB 8.6
6.73-7.00	6.73-7.00	FB 9.0
7.01-7.39	7.01-7.39	FB 9.5
7.40-7.54	7.40-7.54	FB 10
7.55-8.41	7.55-8.41	FB 10.6
8.42-8.91	8.42-8.91	FB 11.2
8.92-9.16	8.92-9.16	FB 12.1
9.17-10.0	9.17-10.0	FB 13.1
10.1-10.3	10.1-10.3	FB 13.9
10.4-11.4	10.4-11.4	FB 14.8
11.5-11.8	11.5-11.8	FB 15.6
11.9-12.9	11.9-12.9	FB 16.4
13.0-13.4	FB 17.6
13.5-14.2	FB 18.4
14.3-15.1	FB 19.4
15.2-18.0	FB 21.1
Following Selections for Size M-1 & M-1P Only.		
....	11.5-11.8	FB 15.6
....	11.9-12.9	FB 16.4
....	13.0-13.4	FB 17.6
....	13.5-14.2	FB 18.4
....	14.3-15.1	FB 19.4
15.2-17.1	15.2-17.1	FB 21.1
17.2-18.0	17.2-18.0	FB 22.6
18.1-18.9	18.1-18.9	FB 23.6
19.0-19.7	19.0-19.7	FB 24.8
19.8-20.9	19.8-20.9	FB 26.7
21.0-21.9	21.0-21.9	FB 28.3
22.0-23.1	22.0-23.1	FB 29.6
23.2-24.3	23.2-24.3	FB 30.5
24.4-25.5	24.4-25.5	FB 32.6
25.6-26.0	25.6-26.0	FB 34.1
Following Selections for Size M-1P Only.		
26.1-26.8	FB 35
26.9-27.3	FB 36.6
27.4-28.7	FB 38.3
28.8-30.2	FB 40.2
30.3-31.9	FB 42
32.0-36.0	FB 44

Table 74

Motor Full-Load Current (Amp)		Thermal Unit Number
1 T. U.	3 T. U.	
2.23-2.47	2.23-2.47	FB 3.33
2.48-2.76	2.48-2.76	FB 3.71
2.77-3.04	2.77-3.04	FB 4.1
3.05-3.24	3.05-3.24	FB 4.5
3.25-3.61	3.25-3.61	FB 4.75
3.62-4.19	3.62-4.19	FB 5.3
4.20-4.62	4.20-4.62	FB 6.1
4.63-5.14	4.63-5.14	FB 6.75
5.15-5.39	5.15-5.39	FB 7.45
5.40-5.69	5.40-5.69	FB 7.8
5.70-5.99	5.70-5.99	FB 8.21
6.00-6.29	6.00-6.29	FB 8.6
6.30-6.64	6.30-6.64	FB 9.0
6.65-6.99	6.65-6.99	FB 9.5
7.00-7.39	7.00-7.39	FB 10
7.40-7.79	7.40-7.79	FB 10.6
7.80-7.94	7.80-7.94	FB 11.2
7.95-8.49	7.95-8.49	FB 12.1
8.50-8.99	8.50-8.99	FB 13.1
9.00-9.59	9.00-9.59	FB 13.9
9.60-10.1	9.60-10.1	FB 14.8
10.2-10.6	10.2-10.6	FB 15.6
10.7-11.3	10.7-11.3	FB 16.4
11.4-12.0	11.4-12.0	FB 17.6
12.0-12.6	FB 18.4
12.7-13.8	FB 19.4
13.9-14.7	FB 21.1
14.8-15.2	FB 22.6
15.3-16.2	FB 23.6
16.3-18.0	FB 24.8
Following Selections for Size 1 Only.		
....	12.0-12.6	FB 18.4
....	12.7-13.8	FB 19.4
13.9-14.7	13.9-14.7	FB 21.1
14.8-15.2	14.8-15.2	FB 22.6
15.3-16.2	15.3-16.2	FB 23.6
16.3-17.4	16.3-17.4	FB 24.8
17.5-18.5	17.5-18.5	FB 26.7
18.6-19.6	18.6-19.6	FB 28.3
19.7-20.2	19.7-20.2	FB 29.6
20.3-21.5	20.3-21.5	FB 30.5
21.6-22.4	21.6-22.4	FB 32.6
22.5-23.2	22.5-23.2	FB 34.1
23.3-24.3	23.3-24.3	FB 35
24.4-25.4	24.4-25.4	FB 36.6
25.5-26.0	25.5-26.0	FB 38.3

Table 75

Motor Full-Load Current (Amp)	Thermal Unit Number
3.22-3.57	FB 4.75
3.58-4.14	FB 5.3
4.15-4.56	FB 6.1
4.57-5.10	FB 6.75
5.11-5.39	FB 7.45
5.40-5.64	FB 7.8
5.65-5.96	FB 8.21
5.97-6.25	FB 8.6
6.26-6.58	FB 9.0
6.59-6.91	FB 9.5
6.92-7.41	FB 10
7.42-7.82	FB 10.6
7.83-8.32	FB 11.2
8.33-8.89	FB 12.1
8.90-9.47	FB 13.1
9.48-10.0	FB 13.9
10.1-10.5	FB 14.8
10.6-11.1	FB 15.6
11.2-12.0	FB 16.4
12.1-12.7	FB 17.6
12.8-13.5	FB 18.4
13.6-14.6	FB 19.4
14.7-15.7	FB 21.1
15.8-16.5	FB 22.6
16.6-17.4	FB 23.6
17.5-18.8	FB 24.8
18.9-20.1	FB 26.7
20.2-21.0	FB 28.3
21.1-21.6	FB 29.6
21.7-23.3	FB 30.5
23.4-24.3	FB 32.6
24.4-25.0	FB 34.1
25.1-26.3	FB 35
26.4-27.6	FB 36.6
27.7-29.1	FB 38.3
29.2-30.4	FB 40.2
30.5-32.0	FB 42
32.1-33.3	FB 44
33.4-35.2	FB 46
35.3-37.0	FB 48
37.1-38.5	FB 50.5
38.6-40.7	FB 52.5
40.8-45.0	FB 55.5

Table 77

Motor Full-Load Current (Amp)	Thermal Unit Number
48.0-50.9	FB 50.5
51.0-53.7	FB 52.5
53.8-57.0	FB 55.5
57.1-60.4	FB 58
60.5-64.0	FB 60
64.1-71.9	FB 63.5
72.0-83.9	FB 69
84.0-93.1	FB 77
93.2-104	FB 84
105-109	FB 92
110-123	FB 105
124-133	FB 115

Table 76

Motor Full-Load Current (Amp)	Thermal Unit Number
19.9-20.8	FB 26.7
20.9-22.2	FB 28.3
22.3-23.8	FB 29.6
23.9-25.4	FB 30.5
25.5-27.2	FB 32.6
27.3-29.2	FB 34.1
29.3-31.9	FB 38.3
32.0-33.8	FB 40.2
33.9-36.1	FB 42
36.2-38.5	FB 44
38.6-41.4	FB 46
41.5-43.6	FB 48
43.7-45.9	FB 50.5
46.0-48.2	FB 52.5
48.3-50.7	FB 55.5
50.8-53.9	FB 58
54.0-56.7	FB 60
56.8-60.8	FB 63.5
60.9-67.6	FB 69
67.6-73.6	FB 77
73.7-82.9	FB 84
83.0-86.0	FB 92



Thermal Unit Selection

Tables 78 thru 83

Table 78

Motor Full-Load Current (Amp)		Thermal Unit Number
1 T. U.	2 T. U. or 3 T. U.	
2.26-2.51	2.26-2.51	FB 3.33
2.52-2.82	2.52-2.82	FB 3.71
2.83-3.09	2.83-3.09	FB 4.1
3.10-3.30	3.10-3.30	FB 4.5
3.31-3.69	3.31-3.69	FB 4.75
3.70-4.27	3.70-4.27	FB 5.3
4.28-4.72	4.28-4.72	FB 6.1
4.73-5.25	4.73-5.25	FB 6.75
5.26-5.53	5.26-5.53	FB 7.45
5.54-5.81	5.54-5.81	FB 7.8
5.82-6.14	5.82-6.14	FB 8.21
6.15-6.44	6.15-6.44	FB 8.6
6.45-6.81	6.45-6.81	FB 9.0
6.82-7.19	6.82-7.19	FB 9.5
7.20-7.59	7.20-7.59	FB 10
7.60-7.99	7.60-7.99	FB 10.6
8.00-8.17	8.00-8.17	FB 11.2
8.18-8.74	8.18-8.74	FB 12.1
8.75-9.31	8.75-9.31	FB 13.1
9.32-9.94	9.32-9.94	FB 13.9
9.95-10.5	9.95-10.5	FB 14.8
10.6-11.1	10.6-11.1	FB 15.6
11.2-11.9	11.2-12.0	FB 16.4
12.0-12.4	FB 17.6
12.5-13.1	FB 18.4
13.2-14.3	FB 19.4
14.4-15.3	FB 21.1
15.4-15.9	FB 22.6
16.0-18.0	FB 23.6
Following Selections for Size 1 Only.		
....	12.0-12.4	FB 17.6
....	12.5-13.1	FB 18.4
....	13.2-14.3	FB 19.4
14.4-15.3	14.4-15.3	FB 21.1
15.4-15.9	15.4-15.9	FB 22.6
16.0-16.9	16.0-16.9	FB 23.6
17.0-18.3	17.0-18.3	FB 24.8
18.4-19.5	18.4-19.5	FB 26.7
19.6-20.5	19.6-20.5	FB 28.3
20.6-21.1	20.6-21.1	FB 29.6
21.2-22.6	21.2-22.6	FB 30.5
22.7-23.7	22.7-23.7	FB 32.6
23.8-24.3	23.8-24.3	
24.4-26.0	24.4-26.0	FB 35

Table 79

Motor Full-Load Current (Amp)	Thermal Unit Number
3.31-3.67	FB 4.75
3.68-4.23	FB 5.3
4.24-4.69	FB 6.1
4.70-5.21	FB 6.75
5.22-5.49	FB 7.45
5.50-5.74	FB 7.8
5.75-6.07	FB 8.21
6.08-6.35	FB 8.6
6.36-6.71	FB 9.0
6.72-7.03	FB 9.5
7.04-7.53	FB 10
7.54-7.91	FB 10.6
7.92-8.53	FB 11.2
8.54-9.14	FB 12.1
9.15-9.71	FB 13.1
9.72-10.2	FB 13.9
10.3-10.8	FB 14.8
10.9-11.5	FB 15.6
11.6-12.3	FB 16.4
12.4-13.0	FB 17.6
13.1-13.9	FB 18.4
14.0-15.1	FB 19.4
15.2-16.1	FB 21.1
16.2-16.9	FB 22.6
17.0-17.9	FB 23.6
18.0-19.4	FB 24.8
19.5-20.7	FB 26.7
20.8-21.7	FB 28.3
21.8-22.3	FB 29.6
22.4-23.9	FB 30.5
24.0-25.1	FB 32.6
25.2-25.9	FB 34.1
26.0-27.1	FB 35
27.2-28.6	FB 36.6
28.7-30.1	FB 38.3
30.2-31.7	FB 40.2
31.8-33.3	FB 42
33.4-34.5	FB 44
34.6-36.5	FB 46
36.6-38.5	FB 48
38.6-39.9	FB 50.5
40.0-45.0	FB 52.5

Table 80

Motor Full-Load Current (Amp)	Thermal Unit Number
20.5-21.7	FB 26.7
21.8-23.1	FB 28.3
23.2-24.8	FB 29.6
24.9-26.5	FB 30.5
26.6-28.4	FB 32.6
28.5-30.4	FB 34.1
30.5-32.8	FB 38.3
32.9-34.9	FB 40.2
35.0-37.3	FB 42
37.4-39.8	FB 44
39.9-42.5	FB 46
42.6-45.8	FB 48
45.9-48.2	FB 50.5
48.3-50.6	FB 52.5
50.7-53.1	FB 55.5
53.2-56.5	FB 58
56.6-59.4	FB 60
59.5-63.4	FB 63.5
63.5-71.0	FB 69
71.1-78.8	FB 77
78.9-86.0	FB 84

Table 82

Motor Full-Load Current (Amp)	Thermal Unit Number
2.36-2.63	FB 3.33
2.64-2.96	FB 3.71
2.97-3.23	FB 4.1
3.24-3.45	FB 4.5
3.46-3.86	FB 4.75
3.87-4.44	FB 5.3
4.45-4.95	FB 6.1
4.96-5.47	FB 6.75
5.48-5.75	FB 7.45
5.76-6.09	FB 7.8
6.10-6.42	FB 8.21
6.43-6.75	FB 8.6
6.76-7.16	FB 9.0
7.17-7.43	FB 9.5
7.44-7.99	FB 10
8.00-8.46	FB 10.6
8.47-9.19	FB 11.2
9.20-9.74	FB 12.1
9.75-10.3	FB 13.1
10.4-10.8	FB 13.9
10.9-11.6	FB 14.8
11.7-12.2	FB 15.6
12.3-13.1	FB 16.4
13.2-13.7	FB 17.6
13.8-14.3	FB 18.4
14.4-15.5	FB 19.4
15.6-16.7	FB 21.1
16.8-17.6	FB 22.6
17.7-18.6	FB 23.6
18.7-19.9	FB 24.8
20.0-21.1	FB 26.7
21.2-25.0	FB 105

Table 81

Motor Full-Load Current (Amp)	Thermal Unit Number
52.2-55.6	FB 50.5
55.7-58.8	FB 52.5
58.9-62.5	FB 55.5
62.6-66.0	FB 58
66.1-70.1	FB 60
70.2-78.6	FB 63.5
78.7-92.0	FB 69
92.1-102	FB 77
103-114	FB 84
115-123	FB 92
124-133	FB 105

Table 83

Motor Full-Load Current (Amp)	Thermal Unit Number
2.30-2.60	FB 3.33
2.61-2.87	FB 3.71
2.88-3.17	FB 4.1
3.18-3.37	FB 4.5
3.38-3.76	FB 4.75
3.77-4.29	FB 5.3
4.30-4.75	FB 6.1
4.76-5.26	FB 6.75
5.27-5.51	FB 7.45
5.52-5.78	FB 7.8
5.79-6.13	FB 8.21
6.14-6.41	FB 8.6
6.42-6.75	FB 9.0
6.76-7.09	FB 9.5
7.10-7.57	FB 10.0
7.58-7.90	FB 10.6
7.91-8.81	FB 11.2
8.82-9.47	FB 12.1
9.48-10.0	FB 13.1
10.1-10.7	FB 13.9
10.8-11.4	FB 14.8
11.5-12.1	FB 15.6
12.2-13.1	FB 16.4
13.2-13.7	FB 17.6
13.8-14.7	FB 18.4
14.8-16.0	FB 19.4
16.1-17.3	FB 21.1
17.4-18.2	FB 22.6
18.3-19.4	FB 23.6
19.5-20.7	FB 24.8
20.8-22.3	FB 26.7
22.4-23.5	FB 28.3
23.6-24.2	FB 29.6
24.3-26.0	FB 30.5

Thermal Unit Selection Tables 84 thru 91

Table 84

Motor Full-Load Current (Amp)	Thermal Unit Number
3.38-3.78	FB 4.75
3.79-4.37	FB 5.3
4.38-4.87	FB 6.1
4.88-5.51	FB 6.75
5.52-5.73	FB 7.45
5.74-6.09	FB 7.8
6.10-6.44	FB 8.21
6.45-6.75	FB 8.6
6.76-7.15	FB 9.0
7.16-7.57	FB 9.5
7.58-8.07	FB 10
8.08-8.47	FB 10.6
8.48-8.81	FB 11.2
8.82-9.46	FB 12.1
9.47-10.1	FB 13.1
10.2-10.8	FB 13.9
10.9-11.4	FB 14.8
11.5-12.1	FB 15.6
12.2-13.1	FB 16.4
13.2-13.8	FB 17.6
13.9-14.8	FB 18.4
14.9-16.1	FB 19.4
16.2-17.4	FB 21.1
17.5-18.3	FB 22.6
18.4-19.5	FB 23.6
19.6-21.0	FB 24.8
21.1-22.5	FB 26.7
22.6-23.7	FB 28.3
23.8-24.5	FB 29.6
24.6-26.4	FB 30.5
26.5-27.7	FB 32.6
27.8-28.7	FB 34.1
28.8-29.9	FB 35
30.0-31.8	FB 36.6
31.9-33.5	FB 38.3
33.6-35.1	FB 40.2
35.2-37.1	FB 42
37.2-38.8	FB 44
38.9-41.1	FB 46
41.2-45.0	FB 48

Table 86

Motor Full-Load Current (Amp)	Thermal Unit Number
0.43-0.44	A 49
0.45-0.47	A 54
0.48-0.53	A 59
0.54-0.61	A 65
0.62-0.65	A 71
0.66-0.71	A 78
0.72-0.79	A 86
0.80-0.86	A 95
0.87-0.96	A 1.02
0.97-1.04	A 1.16
1.05-1.17	A 1.25
1.18-1.31	A 1.39
1.32-1.38	A 1.54
1.39-1.47	A 1.63
1.48-1.57	A 1.75
1.58-1.65	A 1.86
1.66-1.77	A 1.99
1.78-1.93	A 2.15
1.94-2.18	A 2.31
2.19-2.46	A 2.57
2.47-2.68	A 2.81
2.69-2.87	A 3.61
2.88-3.07	A 3.95
3.08-3.59	A 4.32
3.60-3.79	A 4.79
3.80-4.27	A 5.30
4.28-4.59	A 5.78
4.60-4.90	A 6.20
4.91-5.06	A 6.99
5.07-5.44	A 7.65
5.45-6.24	A 8.38
6.25-7.21	A 9.25
7.22-7.69	A 9.85
7.70-8.24	A 11.0
8.25-8.81	A 11.9
8.82-9.32	A 13.2
9.33-9.99	A 14.1
10.0-10.5	A 14.8
10.6-11.5	A 16.2
11.6-12.2	A 17.9
12.3-13.3	A 21.3
13.4-15.8	A 25.2
15.9-18.4	A 27.1
18.5-20.5	A 29.5
20.6-21.5	A 31.9
21.6-23.9	A 33.8
24.0-26.8	A 35.9
26.9-28.2	A 40.0
28.3-29.8	A 42.3
29.9-32.0	A 44.7

Table 87

Motor Full-Load Current (Amp)	Thermal Unit Number
0.40-0.41	A 49
0.42-0.45	A 54
0.46-0.51	A 59
0.52-0.58	A 65
0.59-0.63	A 71
0.64-0.68	A 78
0.69-0.76	A 86
0.77-0.83	A 95
0.84-0.93	A 1.02
0.94-1.01	A 1.16
1.02-1.14	A 1.25
1.15-1.28	A 1.39
1.29-1.34	A 1.54
1.35-1.44	A 1.63
1.45-1.55	A 1.75
1.56-1.61	A 1.86
1.62-1.71	A 1.99
1.72-1.85	A 2.15
1.86-2.04	A 2.31
2.05-2.38	A 2.57
2.39-2.60	A 2.81
2.61-2.77	A 3.61
2.78-2.98	A 3.95
2.99-3.40	A 4.32
3.41-3.64	A 4.79
3.65-4.08	A 5.30
4.09-4.38	A 5.78
4.39-4.68	A 6.20
4.69-4.79	A 6.99
4.80-5.11	A 7.65
5.12-5.84	A 8.38
5.85-6.70	A 9.25
6.71-7.18	A 9.85
7.19-7.70	A 11.0
7.71-8.14	A 11.9
8.15-8.56	A 13.2
8.57-9.15	A 14.1
9.16-9.80	A 14.8
9.81-10.6	A 16.2
10.7-11.0	A 17.9

Table 88

Motor Full-Load Current (Amp)	Thermal Unit Number
0.39-0.40	A 49
0.41-0.44	A 54
0.45-0.49	A 59
0.50-0.57	A 65
0.58-0.61	A 71
0.62-0.66	A 78
0.67-0.73	A 86
0.74-0.80	A 95
0.81-0.90	A 1.02
0.91-0.97	A 1.16
0.98-1.09	A 1.25
1.10-1.23	A 1.39
1.24-1.57	A 1.86
1.58-1.66	A 1.99
1.67-1.79	A 2.15
1.80-1.99	A 2.31
2.00-2.31	A 2.57
2.32-2.50	A 2.81
2.51-2.66	A 3.61
2.67-2.85	A 3.95
2.86-3.26	A 4.32
3.27-3.49	A 4.79
3.50-3.92	A 5.30
3.93-4.20	A 5.78
4.21-4.49	A 6.20
4.50-4.64	A 6.99
4.65-4.94	A 7.65
4.95-5.62	A 8.38
5.63-6.39	A 9.25
6.40-6.82	A 9.85
6.83-7.27	A 11.0
7.28-7.71	A 11.9
7.72-8.13	A 13.2
8.14-8.64	A 14.1
8.65-9.15	A 14.8
9.16-9.97	A 16.2
9.98-11.0	A 17.9

Table 85

Motor Full-Load Current (Amp)	Thermal Unit Number
42.9-45.4	FB 44
45.6-48.3	FB 46
48.4-52.4	FB 48
52.5-55.9	FB 50.5
56.0-59.8	FB 52.5
59.9-63.8	FB 55.5
63.9-67.9	FB 58
68.0-72.6	FB 60
72.7-83.2	FB 63.5
83.3-94.7	FB 69
94.8-105	FB 77
106-116	FB 84
117-121	FB 92
122-133	FB 105

Table 89

Motor Full-Load Current (Amp)	Thermal Unit Number
10.0-11.1	B 17.5
11.2-12.0	B 19.5
12.1-13.3	B 22
13.4-15.1	B 25
15.2-17.1	B 28.0
17.2-18.6	B 32
18.7-21.4	B 36
21.5-25.7	B 40
25.8-28.2	B 45
28.3-29.7	B 50
29.8-31.2	B 56
31.3-32.1	B 62
32.2-35.7	B 70
35.8-40.7	B 79
40.8-48.0	B 88

Table 90

Motor Full-Load Current (Amp)	Thermal Unit Number
4.88-5.13	A7.65
5.14-5.85	A8.38
5.86-6.67	A9.25
6.68-7.09	A9.85
7.10-7.62	A11.0
7.63-8.04	A11.9
8.05-8.46	A13.2
8.47-9.11	A14.1
9.12-9.69	A14.8
9.70-10.5	A16.2
10.6-11.6	A17.9
11.7-12.3	A21.3
12.4-14.6	A25.2
14.7-16.8	A27.1
16.9-17.9	A29.5
18.0-18.7	A31.9
18.8-19.8	A33.8
19.9-21.4	A35.9
21.5-22.8	A40.0
22.9-23.8	A42.3
23.9-26.0	A44.7

Table 91

Motor Full-Load Current (Amp)	Thermal Unit Number
4.80-5.07	A 7.65
5.08-5.73	A 8.38
5.74-6.48	A 9.25
6.49-6.90	A 9.85
6.91-7.25	A 11.0
7.26-7.81	A 11.9
7.82-8.29	A 13.2
8.30-8.81	A 14.1
8.82-9.40	A 14.8
9.41-10.0	A 16.2
10.1-11.1	A 17.9
11.2-11.7	A 21.3
11.8-13.7	A 25.2
13.8-16.0	A 27.1
13.1-16.9	A 29.5
17.0-17.7	A 31.9
17.8-18.7	A 33.8
18.8-20.2	A 35.9
20.3-21.4	A 40.0
21.5-22.5	A 42.3
22.6-23.8	A 44.7
23.9-26.0	A48.0



Thermal Unit Selection

Tables 92 thru 101

Table 92

Motor Full-Load Current (Amp)	Thermal Unit Number
10.5-11.7	B 17.5
11.8-12.5	B 19.5
12.6-14.0	B 22
14.1-15.8	B 25
15.9-18.0	B 28.0
18.1-19.6	B 32
19.7-23.5	B 36
23.6-27.4	B 40
27.6-30.5	B 45
30.6-32.2	B 50
32.3-34.0	B 56
34.1-35.2	B 62
35.3-39.5	B 70
39.6-43.9	B 79
44.0-48.0	B 88

Table 96

Motor Full-Load Current (Amp)	Thermal Unit Number
49.5-52.0	CC 64.3
52.1-54.8	CC 68.5
54.9-58.7	CC 74.6
58.8-63.3	CC 81.5
63.4-68.3	CC 87.7
68.4-73.6	CC 94.0
73.7-79.4	CC 103
79.5-85.5	CC 112
85.6-89.7	CC 121
89.8-94.8	CC 132
94.9-99.9	CC 143
100-105	CC 156
106-111	CC 167
112-126	CC 180
127-131	CC 196
132-141	CC 208
142-150	CC 219

Table 93

Motor Full-Load Current (Amp)	Thermal Unit Number
23.8-25.2	CC 36.4
25.3-26.8	CC 39.6
26.9-28.4	CC 42.7
28.5-30.3	CC 46.6
30.4-32.1	CC 50.1
32.2-34.2	CC 54.5
34.3-36.3	CC 59.4
36.4-40.2	CC 64.3
40.3-43.1	CC 68.5
46.2-45.9	CC 74.6
46.0-49.2	CC 81.5
49.3-51.6	CC 87.7
51.7-54.2	CC 94.0
54.3-55.7	CC 103
55.8-60.3	CC 112
60.4-63.5	CC 121
63.6-67.1	CC 132
67.2-70.3	CC 143
70.4-74.1	CC 156
74.2-78.3	CC 167
78.4-83.3	CC 180
83.4-86.0	CC 196

Table 97

Motor Full-Load Current (Amp)	Thermal Unit Number
0.57-0.60	AR 1.05
0.61-0.66	AR 1.15
0.67-0.73	AR 1.26
0.74-0.81	AR 1.39
0.82-0.90	AR 1.53
0.91-1.05	AR 1.68
1.06-1.15	AR 1.85
1.16-1.25	AR 2.04
1.26-1.35	AR 2.24
1.36-1.47	AR 2.46
1.48-1.58	AR 2.71
1.59-1.74	AR 2.98
1.75-1.94	AR 3.28
1.95-2.20	AR 3.62
2.21-2.47	AR 3.98
2.48-2.76	AR 4.37
2.77-3.07	AR 4.80
3.08-3.45	AR 5.3
3.46-3.81	AR 5.8
3.82-4.20	AR 6.4
4.21-4.65	AR 7.0
4.66-5.29	AR 7.7
5.30-5.84	AR 8.5
5.85-6.27	AR 9.3
6.28-6.97	AR 10.2
6.98-7.59	AR 11.2
7.60-7.89	AR 12.4
7.90-8.95	AR 13.6
8.96-10.3	AR 15.4
10.4-11.7	AR 17.6
11.8-13.3	AR 20.5
13.4-15.2	AR 23
15.3-17.2	AR 27
17.3-19.7	AR 30
19.8-22.4	AR 35
22.5-26.0	AR 40

Table 94

Motor Full-Load Current (Amp)	Thermal Unit Number
25.8-27.5	CC 36.4
27.6-29.4	CC 39.6
29.5-31.4	CC 42.7
31.5-33.2	CC 46.6
33.3-36.2	CC 50.1
36.3-38.8	CC 54.5
38.9-41.6	CC 59.4
41.6-44.7	CC 64.3
44.8-47.9	CC 68.5
48.0-50.9	CC 74.6
51.0-54.4	CC 81.5
54.5-57.4	CC 87.7
57.5-60.6	CC 94.0
60.7-63.9	CC 103
64.0-68.4	CC 112
68.5-73.4	CC 121
73.5-78.7	CC 132
78.8-83.8	CC 143
83.9-86.0	CC 156

Table 98

Motor Full-Load Current (Amp)	Thermal Unit Number
4.24-4.62	AR 8.5
4.63-5.05	AR 9.3
5.06-5.54	AR 10.2
5.55-6.13	AR 11.2
6.14-6.44	AR 12.4
6.45-7.48	AR 13.6
7.49-8.55	AR 15.4
8.56-9.74	AR 17.6
9.75-11.1	AR 20.5
11.2-12.7	AR 23
12.8-14.4	AR 27
14.5-16.4	AR 30
16.5-18.9	AR 35
19.0-21.6	AR 40
21.7-23.3	AR 44
23.4-24.9	AR 47
25.0-26.9	AR 51
27.0-29.1	AR 55
29.2-31.3	AR 60
31.4-33.5	AR 66
33.6-36.9	AR 72
37.0-39.1	AR 79
39.2-40.9	AR 86
41.0-45.0	AR 94

Table 100

Motor Full-Load Current (Amp)	Thermal Unit Number
50-55.9	E 88
56-60.9	E 89
91-65.9	E 91
66-69.9	E 92
70-75.9	E 93
76-81.9	E 94
82-86.9	E 96
87-92.9	E 97
93-97.9	E 98
98-107.9	E 99
108-113.9	E 101
114-125.9	E 102

Table 95

Motor Full-Load Current (Amp)	Thermal Unit Number
42.5-44.7	CC 64.3
44.8-47.9	CC 68.5
48.0-51.2	CC 74.6
51.3-55.2	CC 81.5
55.3-59.4	CC 87.7
59.5-63.8	CC 94.0
63.9-68.8	CC 103
68.9-73.8	CC 112
73.9-77.7	CC 121
77.8-82.5	CC 132
82.6-86.6	CC 143
86.7-91.9	CC 156
92.0-97.2	CC 167
97.3-104	CC 180
105-114	CC 196
115-123	CC 208
124-150	CC 219

Table 99

Motor Full-Load Current (Amp)	Thermal Unit Number
27.1-30.0	E 67
30.1-33.2	E 69
33.3-35.7	E 70
35.8-39.4	E 71
39.5-43.4	E 72
43.5-46.9	E 73
47.0-51.5	E 74
51.6-57.0	E 76
57.1-62.8	E 77
62.9-69.1	E 78
69.2-75.0	E 79
75.1-83.3	E 80

Table 101

Motor Full-Load Current (Amp)	Thermal Unit Number
105-116	AR 3.28
117-132	AR 3.62
133-148	AR 3.98
149-165	AR 4.37
166-184	AR 4.80
185-207	AR 5.3
208-229	AR 5.8
230-266	AR 6.4



Thermal Unit Selection Tables 102 thru 110

Table 102

Motor Full-Load Current (Amp)	Thermal Unit Number
146-169	AR 1.68
170-185	AR 1.85
186-201	AR 2.04
202-217	AR 2.24
218-236	AR 2.46
237-253	AR 2.71
254-279	AR 2.98
280-311	AR 3.28
312-353	AR 3.62
354-396	AR 3.98
397-442	AR 4.37
443-492	AR 4.80
493-520	AR 5.3

Table 103

Motor Full-Load Current (Amp)	Thermal Unit Number
0.57-0.60	AR 1.05
0.61-0.66	AR 1.15
0.67-0.73	AR 1.26
0.74-0.81	AR 1.39
0.82-0.90	AR 1.53
0.91-1.05	AR 1.68
1.06-1.15	AR 1.85
1.16-1.25	AR 2.04
1.26-1.35	AR 2.24
1.36-1.47	AR 2.46
1.48-1.58	AR 2.71
1.59-1.74	AR 2.98
1.75-1.94	AR 3.28
1.95-2.20	AR 3.62
2.21-2.47	AR 3.98
2.48-2.76	AR 4.37
2.77-3.07	AR 4.80
3.08-3.45	AR 5.3
3.46-3.81	AR 5.8
3.82-4.20	AR 6.4
4.21-4.65	AR 7.0
4.66-5.26	AR 7.7
5.30-5.84	AR 8.5
5.85-6.27	AR 9.3
6.28-6.97	AR 10.2
6.98-7.59	AR 11.2
7.60-7.89	AR 12.4
7.90-8.95	AR 13.6
8.96-10.3	AR 15.4
10.4-11.7	AR 17.6
11.8-13.3	AR 20.5
13.4-15.2	AR 23
15.3-17.2	AR 27
17.3-19.7	AR 30
19.8-22.4	AR 35
22.5-26.0	AR 40

Table 104

Motor Full-Load Current (Amp)	Thermal Unit Number
4.24-4.62	AR 8.5
4.63-5.05	AR 9.3
5.06-5.54	AR 10.2
5.55-6.13	AR 11.2
6.14-6.44	AR 12.4
6.45-7.48	AR 13.6
7.49-8.55	AR 15.4
8.56-9.74	AR 17.6
9.75-11.1	AR 20.5
11.2-12.7	AR 23
12.8-14.4	AR 27
14.5-16.4	AR 30
16.5-18.9	AR 35
19.0-21.6	AR 40
21.7-23.3	AR 44
32.4-24.9	AR 47
25.0-26.9	AR 51
27.0-29.1	AR 55
29.2-31.3	AR 60
31.4-33.5	AR 66
33.6-36.9	AR 72
37.0-39.1	AR 79
39.2-40.9	AR 86
41.0-45.0	AR 94

Table 105

Motor Full-Load Current (Amp)	Thermal Unit Number
27.1-30.0	E 67
30.1-33.2	E 69
33.3-35.7	E 70
35.8-39.4	E 71
39.5-43.4	E 72
43.5-46.9	E 73
47.0-51.5	E 74
51.6-57.0	E 76
57.1-62.8	E 77
62.9-69.1	E 78
69.2-75.0	E 79
75.1-83.3	E 80

Table 106

Motor Full-Load Current (Amp)	Thermal Unit Number
50-55.9	E 88
56-60.9	E 89
61-65.9	E 91
66-69.9	E 92
70-75.9	E 93
76-81.9	E 94
82-86.9	E 96
87-92.9	E 97
93-97.9	E 98
98-107.9	E 99
108-113.9	E 101
114-125.9	E 102

Table 107

Motor Full-Load Current (Amp)	Thermal Unit Number
105-116	AR 3.28
117-132	AR 3.62
133-148	AR 3.98
149-165	AR 4.37
166-184	AR 4.80
185-207	AR 5.3
208-229	AR 5.8
230-266	AR 6.4

Table 108

Motor Full-Load Current (Amp)	Thermal Unit Number
146-169	AR 1.68
170-185	AR 1.85
186-201	AR 2.04
202-217	AR 2.24
218-236	AR 2.46
237-253	AR 2.71
254-279	AR 2.98
280-311	AR 3.28
312-353	AR 3.62
354-396	AR 3.98
397-442	AR 4.37
443-492	AR 4.80
493-520	AR 5.3

Table 109

Motor Full-Load Current (Amp)	Thermal Unit Number
0.56-0.63	B 0.81
0.64-0.68	B 0.92
0.69-0.77	B 1.03
0.78-0.85	B 1.16
0.86-0.97	B 1.30
0.98-1.09	B 1.45
1.10-1.21	B 1.67
1.22-1.33	B 1.88
1.34-1.53	B 2.10
1.54-1.73	B 2.40
1.74-1.89	B 2.65
1.90-2.17	B 3.00
2.18-2.53	B 3.30
2.54-2.87	B 3.70
2.88-3.22	B 4.15
3.23-3.49	B 4.85
3.50-3.85	B 5.50
3.86-4.11	B 6.25
4.12-4.70	B 6.90
4.71-5.21	B 7.70
5.22-5.53	B 8.20
5.54-6.17	B 9.10
6.18-7.02	B 10.2
7.03-7.92	B 11.5
7.93-8.61	B 12.8
8.62-9.17	B 14
9.18-10.0	B 15.5
10.1-11.0	B 17.5
11.1-11.8	B 19.5
11.9-13.5	B 22
13.6-15.3	B 25
15.4-17.4	B 28
17.5-19.4	B 32
19.5-22.2	B 36
22.3-25.1	B 40
25.2-27.0	B 45

Table 110

Motor Full-Load Current (Amp)	Thermal Unit Number
3.94-4.45	B 6.90
4.46-4.97	B 7.70
4.98-5.28	B 8.20
5.29-5.97	B 9.10
5.98-6.89	B 10.2
6.90-7.92	B 11.5
7.93-8.71	B 12.8
8.72-9.27	B 14.0
9.28-10.2	B 15.5
10.3-11.4	B 17.5
11.5-12.3	B 19.5
12.4-13.9	B 22
14.0-15.8	B 25
15.9-17.9	B 28
18.0-19.1	B 32
20.0-22.8	B 36
22.9-25.4	B 40
25.5-28.9	B 45
29.0-30.8	B 50
30.9-32.5	B 56
32.6-34.9	B 62
35.0-39.7	B 70
39.8-44.7	B 79



Thermal Unit Selection

Tables 111 thru 120

Table 111

Motor Full-Load Current (Amp)	Thermal Unit Number
14.0-14.9	CC 20.9
15.0-16.2	CC 22.8
16.3-17.2	CC 24.6
17.3-18.7	CC 26.3
18.8-20.2	CC 28.8
20.3-21.7	CC 31.0
21.8-23.3	CC 33.3
23.4-25.2	CC 36.4
25.3-27.1	CC 39.6
27.2-29.4	CC 42.7
29.5-31.6	CC 46.6
31.7-34.0	CC 50.1
34.1-36.8	CC 54.5
36.9-39.8	CC 59.4
39.9-42.3	CC 64.3
42.4-45.7	CC 68.5
45.8-49.2	CC 74.6
49.3-52.6	CC 81.5
52.9-56.8	CC 87.7
56.9-61.2	CC 94.0
61.3-66.1	CC 103
66.2-71.2	CC 112
71.3-76.7	CC 121
76.8-82.9	CC 132
83.0-90.0	CC 143

Table 112

Motor Full-Load Current (Amp)	Thermal Unit Number
44.0-46.8	CC 64.3
46.9-50.6	CC 68.5
50.7-54.5	CC 74.6
54.6-58.4	CC 81.5
58.5-62.9	CC 87.7
63.0-67.7	CC 94.0
67.8-72.9	CC 103
73.0-78.1	CC 112
78.2-83.9	CC 121
84.0-91.1	CC 132
91.2-97.5	CC 143
97.6-104	CC 156
105-113	CC 167
114-133	CC 180

Table 113

Motor Full-Load Current (Amp)	Thermal Unit Number
88.2-95.1	DD 112
95.2-101	DD 121
102-111	DD 128
112-119	DD 140
120-131	DD 150
132-149	DD 160
150-170	DD 185
171-180	DD 220
181-197	DD 240
198-204	DD 250
205-213	DD 265
214-237	DD 280
238-243	DD 300
244-266	DD 320

Table 114

Motor Full-Load Current (Amp)	Thermal Unit Number
133-148	B 1.30
149-174	B 1.45
175-195	B 1.67
196-219	B 1.88
220-239	B 2.10
240-271	B 2.40
272-308	B 2.65
309-348	B 3.00
349-397	B 3.30
398-429	B 3.70
430-495	B 4.15
496-520	B 4.85

Table 115

Motor Full-Load Current (Amp)	Thermal Unit Number
0.56-0.63	B 0.81
0.64-0.68	B 0.92
0.69-0.77	B 1.03
0.78-0.85	B 1.16
0.86-0.97	B 1.30
0.98-1.09	B 1.45
1.10-1.21	B 1.67
1.22-1.33	B 1.88
1.34-1.53	B 2.10
1.54-1.73	B 2.40
1.74-1.89	B 2.65
1.90-2.17	B 3.00
2.18-2.53	B 3.30
2.54-2.87	B 3.70
2.88-3.22	B 4.15
3.23-3.49	B 4.85
3.50-3.85	B 5.50
3.86-4.11	B 6.25
4.12-4.70	B 6.90
4.71-5.21	B 7.70
5.22-5.53	B 8.20
5.54-6.17	B 9.10
6.18-7.02	B 10.2
7.03-7.92	B 11.5
7.93-8.61	B 12.8
8.62-9.17	B 14
9.18-10.0	B 15.5
10.1-11.0	B 17.5
11.1-11.8	B 19.5
11.9-13.5	B 22
13.6-15.3	B 25
15.4-17.4	B 28
17.5-19.4	B 32
19.5-22.2	B 36
22.3-25.1	B 40
25.2-27.0	B 45

Table 116

Motor Full-Load Current (Amp)	Thermal Unit Number
3.94-4.45	B 6.90
4.46-4.97	B 7.70
4.98-5.28	B 8.20
5.29-5.97	B 9.10
5.98-6.89	B 10.2
6.90-7.92	B 11.5
7.93-8.71	B 12.8
8.72-9.27	B 14.0
9.28-10.2	B 15.5
10.3-11.4	B 17.5
11.5-12.3	B 19.5
12.4-13.9	B 22
14.0-15.8	B 25
15.9-17.9	B 28
18.0-19.9	B 32
20.0-22.8	B 36
22.9-25.4	B 40
25.5-28.9	B 45
29.0-30.8	B 50
30.9-32.5	B 56
32.6-34.9	B 62
35.0-39.7	B 70
39.8-44.7	B 79

Table 117

Motor Full-Load Current (Amp)	Thermal Unit Number
14.0-14.9	CC 20.9
15.0-16.2	CC 22.8
16.3-17.2	CC 24.6
17.3-18.7	CC 26.3
18.8-20.2	CC 28.8
20.3-21.7	CC 31.0
21.8-23.3	CC 33.3
23.4-25.2	CC 36.4
25.3-27.1	CC 39.6
27.2-29.4	CC 42.7
29.5-31.6	CC 46.6
31.7-34.0	CC 50.1
34.1-36.8	CC 54.5
36.9-39.8	CC 59.4
39.9-42.3	CC 64.3
42.4-45.7	CC 68.5
45.8-49.2	CC 74.6
49.3-52.6	CC 81.5
52.9-56.8	CC 87.7
56.9-61.2	CC 94.0
61.3-66.1	CC 103
66.2-71.2	CC 112
71.3-76.7	CC 121
76.8-82.9	CC 132
83.0-90.0	CC 143

Table 118

Motor Full-load Current (Amp)	Thermal Unit Number
44.0-46.8	CC 64.3
46.9-50.6	CC 68.5
50.7-54.5	CC 74.6
54.6-58.4	CC 81.5
58.5-62.9	CC 87.7
63.0-67.6	CC 94.0
67.8-72.9	CC 103
73.0-78.1	CC 112
78.2-83.9	CC 121
84.0-91.1	CC 132
91.2-97.5	CC 143
97.6-104	CC 156
105-113	CC 167
114-133	CC 180

Table 119

Motor Full-Load Current (Amp)	Thermal Unit Number
88.2-95.1	DD 112
95.2-101	DD 121
102-111	DD 128
112-119	DD 140
120-131	DD 150
132-149	DD 160
150-170	DD 185
171-180	DD 220
181-197	DD 240
198-204	DD 250
205-213	DD 265
214-237	DD 280
238-243	DD 300
244-266	DD 320

Table 120

Motor Full-Load Current (Amp)	Thermal Unit Number
133-148	B 1.30
149-174	B 1.45
175-195	B 1.67
196-219	B 1.88
220-239	B 2.10
240-271	B 2.40
272-308	B 2.65
309-348	B 3.00
349-397	B 3.30
398-429	B 3.70
430-495	B 4.15
496-520	B 4.85

Thermal Unit Selection Tables 121 thru 128

Table 121

Motor Full-Load Current (Amp)	Thermal Unit Number
1.14-1.21	AR 1.05
1.22-1.33	AR 1.15
1.34-1.47	AR 1.26
1.48-1.63	AR 1.39
1.64-1.81	AR 1.53
1.82-2.11	AR 1.68
2.12-2.31	AR 1.85
2.32-2.51	AR 2.04
2.52-2.71	AR 2.24
2.72-2.95	AR 2.46
2.96-3.17	AR 2.71
3.18-3.49	AR 2.98
3.50-3.89	AR 3.28
3.90-4.41	AR 3.62
4.42-4.95	AR 3.98
4.96-5.53	AR 4.37
5.54-6.15	AR 4.80
6.16-6.91	AR 5.3
6.92-7.63	AR 5.8
7.64-8.41	AR 6.4
8.42-9.31	AR 7.0
9.32-10.59	AR 7.7
10.60-11.69	AR 8.5
11.70-12.55	AR 9.3
12.56-13.95	AR 10.2
13.96-15.19	AR 11.2
15.20-15.79	AR 12.4
15.80-17.91	AR 13.6
17.92-20.7	AR 15.4
20.8-23.5	AR 17.6
23.6-26.7	AR 20.5
26.8-30.5	AR 23
30.6-34.5	AR 27
34.6-39.5	AR 30
39.6-44.9	AR 35
45.0-52.0	AR 40

Table 122

Motor Full-Load Current (Amp)	Thermal Unit Number
8.48-9.25	AR 8.5
9.26-10.11	AR 9.3
10.12-11.09	AR 10.2
11.10-12.27	AR 11.2
12.28-12.89	AR 12.4
12.90-14.97	AR 13.6
14.98-17.11	AR 15.4
17.12-19.49	AR 17.6
19.50-22.3	AR 20.5
22.4-22.5	AR 23
22.6-28.9	AR 27
29.0-32.9	AR 30
33.0-37.9	AR 35
38.0-43.3	AR 40
43.4-46.7	AR 44
46.8-49.9	AR 47
50.0-53.9	AR 51
54.0-58.3	AR 55
58.4-62.7	AR 60
62.8-67.1	AR 66
67.2-73.8	AR 72
74.0-78.3	AR 79
78.4-81.9	AR 86
82.0-90.0	AR 94

Table 123

Motor Full-Load Current (Amp)	Thermal Unit Number
54.2-60.1	E 67
60.2-66.5	E 69
66.6-71.5	E 70
71.6-78.9	E 71
79.0-86.9	E 72
87.0-93.9	E 73
94.0-103.1	E 74
103.2-114.1	E 76
114.2-125.7	E 77
125.8-138.3	E 78
138.4-150.1	E 79
150.2-166.6	E 80

Table 124

Motor Full-Load Current (Amp)	Thermal Unit Number
1.14-1.21	AR 1.05
1.22-1.33	AR 1.15
1.34-1.47	AR 1.26
1.48-1.63	AR 1.39
1.64-1.81	AR 1.53
1.82-2.11	AR 1.68
2.12-2.31	AR 1.85
2.32-2.51	AR 2.04
2.52-2.71	AR 2.24
2.72-2.95	AR 2.46
2.96-3.17	AR 2.71
3.18-3.49	AR 2.98
3.50-3.89	AR 3.28
3.90-4.41	AR 3.62
4.42-4.95	AR 3.98
4.96-5.53	AR 4.37
5.54-6.15	AR 4.80
6.16-6.91	AR 5.3
6.92-7.63	AR 5.8
7.64-8.41	AR 6.4
8.42-9.31	AR 7.0
9.32-10.59	AR 7.7
10.60-11.69	AR 8.5
11.70-12.55	AR 9.3
12.56-13.95	AR 10.2
13.96-15.19	AR 11.2
15.20-15.79	AR 12.4
15.80-17.91	AR 13.6
17.92-20.7	AR 15.4
20.8-23.5	AR 17.6
23.6-26.7	AR 20.5
26.8-30.5	AR 23
30.6-34.5	AR 27
34.6-39.5	AR 30
39.6-44.9	AR 35
45.0-52.0	AR 40

Table 125

Motor Full-Load Current (Amp)	Thermal Unit Number
8.48-9.25	AR 8.5
9.26-10.11	AR 9.3
10.12-11.09	AR 10.2
11.10-12.27	AR 11.2
12.28-12.89	AR 12.4
12.90-14.97	AR 13.6
14.98-17.11	AR 15.4
17.12-19.49	AR 17.6
19.50-22.3	AR 20.5
22.4-22.5	AR 23
22.6-28.9	AR 27
29.0-32.9	AR 30
33.0-37.9	AR 35
38.0-43.3	AR 40
43.4-46.7	AR 44
46.8-49.9	AR 47
50.0-53.9	AR 51
54.0-58.3	AR 55
58.4-62.7	AR 60
62.8-67.1	AR 66
67.2-73.8	AR 72
74.0-78.3	AR 79
78.4-81.9	AR 86
82.0-90.0	AR 94

Table 126

Motor Full-Load Current (Amp)	Thermal Unit Number
54.2-60.1	E 67
60.2-66.5	E 69
66.6-71.5	E 70
71.6-78.9	E 71
79.0-86.9	E 72
87.0-93.9	E 73
94.0-103.1	E 74
103.2-114.1	E 76
114.2-125.7	E 77
125.8-138.3	E 78
138.4-150.1	E 79
150.2-166.6	E 80

Table 127

Motor Full-load Current (Amp)	Thermal Unit Number
1.12-1.27	B 0.81
1.28-1.37	B 0.92
1.38-1.55	B 1.03
1.56-1.71	B 1.16
1.72-1.95	B 1.30
1.96-2.19	B 1.45
2.20-2.43	B 1.67
2.44-2.67	B 1.88
2.68-3.07	B 2.10
3.08-3.47	B 2.40
3.48-3.79	B 2.65
3.80-4.35	B 3.00
4.36-5.07	B 3.30
5.08-5.75	B 3.70
5.76-6.45	B 4.15
6.46-6.99	B 4.85
7.00-7.71	B 5.50
7.72-8.23	B 6.25
8.24-9.41	B 6.90
9.42-10.43	B 7.70
10.44-11.07	B 8.20
11.08-12.35	B 9.10
12.36-14.05	B 10.2
14.06-15.85	B 11.5
15.86-17.23	B 12.8
17.24-18.35	B 14
18.36-20.1	B 15.5
20.2-22.1	B 17.5
22.2-23.7	B 19.5
23.8-27.1	B 22
27.2-30.7	B 25
30.8-34.9	B 28
35.0-38.9	B 32
39.0-44.5	B 36
44.6-50.3	B 40
50.4-54.0	B 45

Table 128

Motor Full-load Current (Amp)	Thermal Unit Number
7.88-8.91	B 6.90
8.92-9.95	B 7.70
9.96-10.57	B 8.20
10.58-11.95	B 9.10
11.96-13.79	B 10.2
13.80-15.85	B 11.5
15.86-17.43	B 12.8
17.44-18.55	B 14.0
18.56-20.5	B 15.5
20.6-22.9	B 17.5
23.0-24.7	B 19.5
24.8-27.9	B 22
28.0-31.7	B 25
31.8-35.9	B 28
36.0-39.9	B 32
40.0-45.7	B 36
45.8-50.9	B 40
51.0-61.7	B 45
61.8-65.1	B 50
65.2-69.9	B 56
70.0-79.5	B 62
79.6-89.4	B 70



Thermal Unit Selection

Tables 129 thru 136

Table 129

Motor Full-load Current (Amp)	Thermal Unit Number
28.0-29.2	CC 20.9
30.0-32.5	CC 22.8
32.6-34.5	CC 24.6
34.6-37.5	CC 26.3
37.6-40.5	CC 28.8
40.6-43.5	CC 31.0
43.6-46.7	CC 33.3
46.8-50.5	CC 36.4
50.6-54.3	CC 39.6
54.4-58.9	CC 42.7
59.0-63.3	CC 46.6
63.4-68.1	CC 50.1
68.2-73.7	CC 54.5
73.8-79.7	CC 59.4
79.8-84.7	CC 64.5
84.8-91.5	CC 68.5
91.6-98.5	CC 74.6
98.6-105.7	CC 81.5
105.8-113.7	CC 87.7
113.8-122.5	CC 94.0
122.6-132.3	CC 103
132.4-142.5	CC 112
142.6-153.5	CC 121
153.6-165.9	CC 132
166.0-180.0	CC 143

Table 133

Motor Full-load Current (Amp)	Thermal Unit Number
4.60-5.23	B 6.90
5.24-5.86	B 7.70
5.87-6.25	B 8.20
6.26-7.09	B 9.10
7.10-8.25	B 10.2
8.26-9.49	B 11.5
9.50-10.3	B 12.8
10.4-11.2	B 14
11.3-12.5	B 15.5
12.6-13.8	B 17.5
13.9-15.0	B 19.5
15.1-16.9	B 22
17.0-19.1	B 25
19.2-22.0	B 28.0
22.1-24.4	B 32
24.5-28.0	B 36
28.1-31.8	B 40
31.9-36.0	B 45
36.1-38.5	B 50
38.6-41.2	B 56
41.3-44.4	B 62
44.5-50.3	B 70
50.4-56.9	B 79
57.0-59.0	B 88

Table 130

Motor Full-load Current (Amp)	Thermal Unit Number
1.12-1.27	B 0.81
1.28-1.37	B 0.92
1.38-1.55	B 1.03
1.56-1.71	B 1.16
1.72-1.95	B 1.30
1.96-2.19	B 1.45
2.20-2.43	B 1.67
2.44-2.67	B 1.88
2.68-3.07	B 2.10
3.08-3.47	B 2.40
3.48-3.79	B 2.65
3.80-4.35	B 3.00
4.36-5.07	B 3.30
5.08-5.75	B 3.70
5.76-6.45	B 4.15
6.46-6.99	B 4.85
7.00-7.71	B 5.50
7.72-8.23	B 6.25
8.24-9.41	B 6.90
9.42-10.43	B 7.70
10.44-11.07	B 8.20
11.08-12.35	B 9.10
12.36-14.05	B 10.2
14.06-15.85	B 11.5
15.86-17.23	B 12.8
17.24-18.35	B 14
18.36-20.1	B 15.5
20.2-22.1	B 17.5
22.2-23.7	B 19.5
23.8-27.1	B 22
27.2-30.7	B 25
30.8-34.9	B 28
25.0-38.9	B 32
39.0-44.5	B 36
44.6-50.3	B 40
50.4-54.0	B 45

Table 134

Motor Full-load Current (Amp)	Thermal Unit Number
4.30-4.98	B 6.90
4.99-5.57	B 7.70
5.58-5.94	B 8.20
5.95-6.71	B 9.10
6.72-7.79	B 10.2
7.80-8.93	B 11.5
8.94-9.77	B 12.8
9.78-10.5	B 14
10.6-11.7	B 15.5
11.8-13.0	B 17.5
13.1-14.0	B 19.5
14.1-15.0	B 22
15.1-17.2	B 25
17.3-19.9	B 28.0
20.0-22.3	B 32
22.4-26.0	B 36
26.1-29.8	B 40
29.9-34.0	B 45
34.1-36.7	B 50
36.8-39.5	B 56
39.6-42.1	B 62
42.2-46.6	B 70
46.7-51.5	B 79
51.6-54.0	B 88

Table 131

Motor Full-load Current (Amp)	Thermal Unit Number
7.88-8.91	B 6.90
8.92-9.95	B 7.70
9.96-10.57	B 8.20
10.58-11.95	B 9.10
11.96-13.79	B 10.2
13.80-15.85	B 11.5
15.86-17.43	B 12.8
17.44-18.55	B 14.0
18.56-20.5	B 15.5
20.6-22.9	B 17.5
23.0-24.7	B 19.5
24.8-27.9	B 22
28.0-31.7	B 25
31.8-35.9	B 28
36.0-39.9	B 32
40.0-45.7	B 36
45.8-50.9	B 40
51.0-61.7	B 45
61.8-65.1	B 50
65.2-69.9	B 56
70.0-79.5	B 62
79.6-89.4	B 70

Table 135

Motor Full-load Current (Amp)		Thermal Unit Number
1 T. U.	3 T. U.	
0.77-0.88	0.85-0.95	B 1.30
0.89-1.02	0.96-1.09	B 1.45
1.03-1.19	1.10-1.21	B 1.67
1.20-1.37	1.22-1.35	B 1.88
1.38-1.62	1.36-1.56	B 2.10
1.63-1.90	1.57-1.76	B 2.40
1.91-2.12	1.77-1.94	B 2.65
2.13-2.46	1.95-2.22	B 3.00
2.47-2.83	2.23-2.57	B 3.30
2.84-3.19	2.58-2.87	B 3.70
3.20-3.61	2.88-3.21	B 4.15
3.62-3.89	3.22-3.50	B 4.85
3.90-4.32	3.51-3.79	B 5.50
4.33-4.57	3.80-4.04	B 6.25
4.58-5.19	4.05-4.53	B 6.90
5.20-5.79	4.54-5.03	B 7.70
5.80-6.16	5.04-5.36	B 8.20
6.17-6.94	5.37-5.97	B 9.10
6.95-7.99	5.98-6.89	B 10.2
7.80-8.99	6.90-7.79	B 11.5
9.00-9.98	7.80-8.53	B 12.8
9.99-10.6	8.54-9.09	B 14
10.7-11.6	9.10-9.99	B 15.5
11.7-13.1	10.0-10.9	B 17.5
13.2-14.2	11.0-11.7	B 19.5
14.3-15.4	11.8-13.4	B 22
15.5-17.6	13.5-15.4	B 25
17.7-20.0	15.5-17.9	B 28.0
-	18.0-20.0	B 32
For Type DPSG-12 & DPSG-13, 20 Ampere Starter Select Thermal Units From Above.		
20.1-22.7	18.0-20.2	B 32
22.8-25.0	20.3-23.2	B 36
-	23.3-25.0	B 40
For Type DPSG-22 & DPSG-23, 25 Ampere Starter Select Any Of The Thermal Units From Above.		
-	-	B 34
22.8-26.1	23.3-25.8	B 40
26.2-29.6	25.9-28.6	B 45
29.7-30.0	28.7-29.7	B 50
-	29.8-30.0	B 56
For Type DPSG-32 & DPSG-33, 30 Ampere Starter Select Any Of The Thermal Units From Above.		
23.7-27.2	24.2-27.2	B 36
27.3-30.0	27.3-30.0	B 40
-	-	B 45

Table 132

Motor Full-load Current (Amp)	Thermal Unit Number
28.0-29.9	CC 20.9
30.0-32.5	CC 22.8
32.6-34.5	CC 24.6
34.6-37.5	CC 26.3
37.6-40.5	CC 28.8
40.6-43.5	CC 31.0
43.6-46.7	CC 33.3
46.8-50.5	CC 36.4
50.6-54.3	CC 39.6
54.4-58.9	CC 42.7
59.0-63.3	CC 46.6
63.4-68.1	CC 50.1
68.2-37.7	CC 54.5
73.8-79.7	CC 59.4
79.8-84.7	CC 64.3
84.8-91.5	CC 68.5
91.6-98.5	CC 74.6
98.6-105.7	CC 81.5
105.8-113.7	CC 87.7
113.8-122.5	CC 94.0
122.6-132.3	CC 103
132.4-142.5	CC 112
142.6-153.5	CC 121
135.6-165.9	CC 132
166.0-180.0	CC 143

Table 136

Motor Full-load Current (Amp)		Thermal Unit Number
1 T. U.	3 T. U.	
0.98-1.09	0.88-0.98	B 1.30
1.10-1.24	0.99-1.13	B 1.45
1.25-1.41	1.14-1.26	B 1.67
1.42-1.59	1.27-1.38	B 1.88
1.60-1.81	1.39-1.62	B 2.10
1.82-2.04	1.63-1.82	B 2.40
2.05-2.19	1.83-2.04	B 2.65
2.20-2.52	2.05-2.36	B 3.00
2.53-2.90	2.37-2.72	B 3.30
2.91-3.29	2.73-3.07	B 3.70
3.30-3.69	3.08-3.44	B 4.15
3.70-3.99	3.45-3.69	B 4.85
4.00-4.42	3.70-4.11	B 5.50
4.43-4.69	4.12-4.34	B 6.25
4.70-5.37	4.35-4.89	B 6.90
5.38-5.94	4.90-5.44	B 7.70
5.95-6.34	5.45-5.80	B 8.20
6.35-7.05	5.81-6.47	B 9.10
7.06-8.14	6.48-7.45	B 10.2
8.15-9.39	7.46-8.49	B 11.5
9.40-10.3	8.50-9.29	B 12.8
10.4-11.1	9.30-9.99	B 14
11.2-12.2	10.0-10.8	B 15.5
12.3-13.5	10.9-12.1	B 17.5
13.6-14.7	12.2-13.1	B 19.5
14.8-16.1	13.2-14.6	B 22
16.2-18.3	14.7-16.4	B 25
18.4-20.0	16.5-18.9	B 28.0
-	19.0-20.0	B 32
For Type DPSO-12 & DPSO-13, 20 Ampere Starter Select Thermal Units From Above.		
18.4-20.9	-	B 28.0
21.0-23.6	19.0-20.9	B 32
23.7-25.0	21.0-24.1	B 36
-	24.2-25.0	B 40
For Type DPSO-22 & DPSO-23, 25 Ampere Starter Select Any Of The Thermal Units From Above.		
23.7-27.2	24.2-27.2	B 36
27.3-30.0	27.3-30.0	B 40
-	-	B 45
For Type DPSO-32 & DPSO-33, 30 Ampere Starter Select Any Of The Thermal Units From Above.		



Thermal Unit Selection Tables 137 thru 144

Table 137

Motor Full-load Current (Amp)	Thermal Unit Number
50-55.9	E 88
56-60.9	E 89
61-65.9	E 91
66-69.9	E 92
70-75.9	E 93
76-81.9	E 94
82-86.9	E 96
87-92.9	E 97
93-97.9	E 98
98-107	E 99
108-113	E 101
114-125	E 102
126-138	E 103
139-153	E 104
154-163	E 106
164-180	E 107

Table 138

Motor Full-load Current (Amp)	Thermal Unit Number
22.6-25.5	E 62
25.6-26.4	E 65
26.5-28.9	E 66
29.0-31.9	E 67
32.0-34.5	E 69
34.6-36.9	E 70
37.0-40.6	E 71
40.7-44.0	E 72
44.1-47.4	E 73
47.5-53.1	E 74
53.2-58.3	E 76
58.4-63.5	E 77
63.6-69.9	E 78
70.0-77.1	E 79
77.2-83.3	E 80
83.4-86.9	E 96
87.0-92.9	E 97
93.0-100	E 98

Table 139

Motor Full-load Current (Amp)	Thermal Unit Number
13.7-15.2	E 57
15.3-16.8	E 59
16.9-18.7	E 60
18.8-20.0	E 61
20.1-22.5	E 62
22.6-23.3	E 65
23.4-25.5	E 66
25.6-27.9	E 67
28.0-30.8	E 69
30.9-33.2	E 70
33.3-36.6	E 71
36.7-38.9	E 72
39.0-43.1	E 73
43.2-47.4	E 74
47.5-50.0	E 76
50.1-55.2	E 77
55.3-60.0	E 78

Table 140

Motor Full-load Current (Amp)	Thermal Unit Number
0.34-0.36	E 3
0.37-0.40	E 4
0.41-0.43	E 5
0.44-0.47	E 6
0.48-0.51	E 7
0.52-0.56	E 8
0.57-0.62	E 9
0.63-0.67	E 11
0.68-0.73	E 12
0.74-0.77	E 13
0.78-0.84	E 14
0.85-0.93	E 16
0.94-1.00	E 17
1.01-1.08	E 18
1.09-1.15	E 19
1.16-1.27	E 23
1.28-1.45	E 24
1.46-1.61	E 26
1.62-1.81	E 27
1.82-2.00	E 28
2.01-2.12	E 29
2.13-2.29	E 31
2.30-2.43	E 32
2.44-2.66	E 33
2.67-2.98	E 34
2.99-3.16	E 36
3.17-3.39	E 37
3.40-3.69	E 38
3.70-4.00	E 39
4.01-4.48	E 41
4.49-5.00	E 42
5.01-5.44	E 44
5.45-5.99	E 46
6.00-6.60	E 47
6.61-6.96	E 48
6.97-7.26	E 49
7.27-7.99	E 50
8.00-8.89	E 51
8.90-9.74	E 52
9.75-10.50	E 53

Table 141

Motor FLC (A)	Thermal Unit No.	Max. Fuse Rating (A)	Motor FLC (A)	Thermal Unit No.	Max. Fuse Rating (A)
12.2-14.4	E56	25	43.4-46.9	E73A	90 100
14.5-17.8	E57	30	47.0-50.1	E74	600V Max. 250V Max.
17.9-18.8	E60	40			100 110
18.9-21.4	E61	40	50.2-54.0	E76	100 110
21.5-23.0	E62	45			100 110
23.1-25.7	E65	50	54.1-58.0	E77	100 110
25.8-28.0	E66	50	58.1-60.0	E78	100 125
28.1-31.0	E67	60	60.1-67.0	E79	100 125
31.1-32.7	E69	60	67.1-70.5	E80	100 125
32.8-35.5	E70	70	70.6-75.9	E94	100 125
35.6-38.2	E71	80	76.0-82.0	E96	100 125
38.3-43.3	E73	80	82.1-86.0	E97	100 125

Table 142

Motor FLC (A)	Thermal Unit No.	Max. Fuse Rating (A)	Motor FLC (A)	Thermal Unit No.	Max. Fuse Rating (A)
11.7-13.5	E56	25	40.0-43.8	E73A	90 90 100
13.6-16.7	E57	30	43.9-46.2	E74	600V Max. 250V Max.
16.8-18.1	E60	35	46.3-50.0	E76	100 110
18.2-20.0	E61	40			100 110
20.1-21.9	E62	40			100 110
22.0-24.2	E65	45	50.1-53.9	E77	100 110
			54.0-56.0	E78	100 110
24.3-26.2	E66	50	56.1-61.0	E79	100 125
26.3-29.2	E67	50	61.1-65.9	E80	100 125
29.3-32.0	E69	60	66.0-72.0	E94	100 125
32.1-34.3	E70	70	72.1-75.9	E96	100 125
34.4-36.2	E71	70	76.0-79.9	E98	100 125
36.3-39.9	E73	80	80.0-86.0	E101	100 125

10.6-11.5	E 54
11.6-12.3	E 55
12.4-13.4	E 56
13.5-15.2	E 57
15.3-17.2	E 60
17.3-18.4	E 61
18.5-20.6	E 62
20.7-21.3	E 65
21.4-23.4	E 66
23.5-24.0	E 67

Table 143

Motor FLC (A)	Thermal Unit No.	Max. Fuse Rating (A)	Motor FLC (A)	Thermal Unit No.	Max. Fuse Rating (A)
18.9-20.0	E60	40	56.4-61.0	E76	125
20.1-22.8	E61	45	61.1-64.0	E77	125
22.9-24.7	E62	50	64.1-66.0	E78	125
24.8-26.9	E65	50	66.1-72.4	E79	125
27.0-29.2	E66	60	72.5-78.2	E80	150
29.3-32.8	E67	60	78.3-83.9	E94	175
32.9-34.9	E69	70	84.0-86.0	E96	175
35.0-37.5	E70	70	86.1-92.8	E97	175
37.6-39.6	E72	80	92.9-97.9	E98	200
39.7-46.1	E73	80	98.0-105.0	E101	200
46.2-49.9	E73A	100	105.1-117.0	E102	200
50.0-56.3	E74	110	117.1-133.0	E103	200

Table 144

Motor FLC (A)	Thermal Unit No.	Max. Fuse Rating (A)	Motor FLC (A)	Thermal Unit No.	Max. Fuse Rating (A)
18.2-19.1	E60	40	52.7-56.0	E76	110
19.2-22.1	E61	40	56.1-58.4	E77	125
22.2-23.1	E62	45	58.5-61.9	E78	125
23.2-25.7	E65	50	62.0-67.1	E79	125
25.8-27.7	E66	50	67.2-72.3	E80	150
27.8-31.3	E67	60	72.4-75.9	E94	150
31.4-33.3	E69	70	76.0-85.6	E96	150
33.4-35.9	E70	70	85.7-91.2	E98	175
36.0-38.4	E71	80	91.3-100.0	E101	200
38.5-44.2	E73	80	100.1-108.9	E102	200
44.3-46.8	E73A	90	109.0-119.9	E103	200
46.9-52.6	E74	100	120.0-133.0	E104	200



Thermal Unit Selection Tables 145 thru 148

Table 145

Motor Full-load Current (Amp)		Thermal Unit Number
1 T.U.	3 T.U.	
1.00-1.11	0.91-1.02	B1.30
1.12-1.27	1.03-1.15	B1.45
1.28-1.36	1.16-1.27	B1.67
1.37-1.53	1.28-1.39	B1.88
1.54-1.78	1.40-1.61	B2.10
1.79-2.02	1.62-1.84	B2.40
2.03-2.20	1.85-2.03	B2.65
2.21-2.52	2.04-2.34	B3.00
2.53-2.94	2.35-2.69	B3.30
2.95-3.30	2.70-3.02	B3.70
3.31-3.70	3.03-3.39	B4.15
3.71-4.02	3.40-3.65	B4.85
4.03-4.46	3.66-4.04	B5.50
4.47-4.69	4.05-4.28	B6.25
4.70-5.37	4.29-4.85	B6.90
5.38-5.94	4.86-5.38	B7.70
5.95-6.34	5.39-5.71	B8.20
6.35-7.09	5.72-6.39	B9.10
7.10-8.46	6.40-7.53	B10.2
8.47-9.32	7.54-8.34	B11.5
9.33-10.2	8.35-9.14	B12.8
10.3-10.9	9.15-9.74	B14
11.0-12.1	9.75-10.7	B15.5
12.2-13.4	10.8-11.8	B17.5
13.5-14.2	11.9-12.2	B19.5
14.3-16.0	12.3-14.4	B22
16.1-18.1	14.5-16.4	B25
18.2-20.5	16.5-18.9	B28.0
20.6-23.5	19.0-21.3	B32
23.6-27.2	21.4-23.3	B36
27.3-30.8	23.4-27.9	B40
30.9-35.0	26.0-31.4	B45
35.1-37.2	31.5-32.5	B50
37.3-40.0	32.6-36.5	B56
....	36.6-40.0	B62

For Type DPSG-42 & DPSG-43, 40 Ampere Starter. Select any of the Thermal Units from above.

Table 146

Motor Full-load Current (Amp)		Thermal Unit Number
1 T.U.	3 T.U.	
3.90-4.22	3.60-3.89	B5.50
4.23-4.49	3.90-4.15	B6.25
4.50-5.14	4.16-4.76	B6.90
5.15-5.78	4.77-5.30	B7.70
5.79-6.23	5.31-5.70	B8.20
6.24-7.03	5.71-6.46	B9.10
7.04-8.23	6.47-7.65	B10.2
8.24-9.31	7.66-8.55	B11.5
9.32-10.1	8.56-9.36	B12.8
10.2-10.7	9.37-9.9	B14
10.8-11.9	10.0-10.9	B15.5
12.0-13.1	11.0-12.0	B17.5
13.2-13.9	12.1-12.8	B19.5
14.0-15.9	12.9-14.2	B22
16.0-18.0	14.3-16.0	B25
18.1-20.8	16.1-18.5	B28.0
20.9-23.1	18.6-21.2	B32
23.2-26.9	21.3-24.9	B36
27.0-31.4	25.0-28.0	B40
31.5-36.0	28.1-31.7	B45
36.1-38.8	31.8-34.6	B50
38.9-41.7	34.7-37.4	B56
41.8-46.3	37.5-40.0	B62
46.4-50.0	40.1-46.4	B70
....	46.5-50.0	B79

For Type DPSG-52 & DPSG-53, 50 Ampere Starter. Select any of the Thermal Units from above.

Table 147

Motor Full-load Current (Amp)		Thermal Unit Number
1 T.U.	3 T.U.	
1.04-1.14	0.93-1.04	B1.30
1.15-1.29	1.05-1.18	B1.45
1.30-1.43	1.19-1.33	B1.67
1.44-1.56	1.34-1.43	B1.88
1.57-1.79	1.44-1.67	B2.10
1.80-2.03	1.59-1.88	B2.40
2.04-2.26	1.89-2.09	B2.65
2.27-2.51	2.10-2.41	B3.00
2.52-3.03	2.42-2.79	B3.30
3.04-3.31	2.80-3.15	B3.70
3.32-3.73	3.16-3.54	B4.15
3.74-4.07	3.55-3.75	B4.85
4.08-4.49	3.76-4.22	B5.50
4.50-4.76	4.23-4.46	B5.25
4.77-5.44	4.47-5.09	B6.90
5.45-6.04	5.10-5.61	B7.70
6.05-6.46	5.62-5.99	B8.20
6.47-7.24	6.00-6.70	B9.10
7.25-8.64	6.71-8.19	B10.20
8.65-9.59	8.20-8.79	B11.5
9.60-10.5	8.80-9.66	B12.8
10.6-11.3	9.67-10.2	B14
11.4-12.6	10.3-11.4	B15.5
12.7-13.9	11.5-12.6	B17.5
14.0-14.9	12.7-13.5	B19.5
15.0-16.5	13.6-15.1	B22
16.6-18.9	15.2-17.2	B25
19.0-22.2	17.3-19.9	B28.0
22.3-24.6	20.0-22.5	B32
24.7-28.6	22.6-26.2	B36
28.7-32.4	26.3-29.9	B40
32.5-37.3	30.3-34.0	B45
37.4-39.5	34.1-36.2	B50
39.6-40.0	36.3-38.7	B56
....	38.8-40.0	B62

For Type DPSO-42 & DPSO-43, 40 Ampere Starter. Select any of the Thermal Units from above.

Table 148

Motor Full-load Current (Amp)		Thermal Unit Number
1 T.U.	3 T.U.	
4.14-4.45	3.70-4.09	B5.50
4.46-4.88	4.10-4.35	B6.25
4.89-5.44	4.36-5.07	B6.90
5.45-6.08	5.08-5.79	B7.70
6.09-6.42	5.80-6.27	B8.20
6.43-7.28	6.28-7.16	B9.10
7.29-8.42	7.17-8.58	B10.2
8.43-9.64	8.59-9.55	B11.5
9.65-10.4	9.56-10.2	B12.8
10.5-11.2	10.3-10.9	B14
11.3-12.3	11.0-11.9	B15.5
12.4-13.7	12.0-13.1	B17.5
13.8-14.8	13.2-14.0	B19.5
14.9-16.5	14.1-14.8	B22
16.6-18.7	14.9-17.0	B25
18.8-21.4	17.1-19.6	B28.0
21.5-24.3	19.7-22.1	B32
24.4-28.0	22.2-26.0	B36
28.1-33.3	26.1-29.4	B40
33.4-37.6	29.5-34.0	B45
37.7-41.1	34.1-36.4	B50
41.2-44.1	36.5-39.2	B56
44.2-47.8	39.3-42.4	B62
47.9-50.0	42.5-49.3	B70
....	49.4-50.0	B79

For Type DPSO-52 & DPSO-53, 50 Ampere Starter. Select any of the Thermal Units from above.

Table 149

Motor Full-load Current (Amp)	Thermal Unit Number
56.4-62.3	AR1.53
62.4-74.3	AR1.68
74.4-81.5	AR1.85
81.6-88.7	AR2.04
88.8-97.1	AR2.24
97.2-106	AR2.46
107-116	AR2.71
117-127	AR2.98
128-141	AR3.28
142-157	AR3.62
158-167	AR3.98
168-188	AR4.37
189-209	AR4.80
210-233	AR5.30
234-266	AR5.80

Table 150

Motor Full-load Current (Amp)	Thermal Unit Number
49.2-54.5	AR1.53
54.6-63.5	AR1.68
63.6-69.5	AR1.85
69.6-75.5	AR2.04
75.6-81.5	AR2.24
81.6-88.7	AR2.46
88.8-95.3	AR2.71
95.4-104	AR2.98
105-116	AR3.28
117-132	AR3.62
133-148	AR3.98
149-166	AR4.37
167-184	AR4.80
185-207	AR5.30
208-229	AR5.80
230-266	AR6.40

Table 151

Motor Full-load Current (Amp)	Thermal Unit Number
40.8-45.5	B1.03
45.6-49.9	B1.16
51.0-57.5	B1.30
57.6-65.9	B1.45
66.0-73.1	B1.67
73.2-81.5	B1.88
81.6-92.3	B2.10
92.4-104	B2.40
105-114	B2.65
115-128	B3.00
129-140	B3.30
141-160	B3.70
161-193	B4.15
194-209	B4.85
210-232	B5.50
233-248	B6.25
249-266	B6.90

Table 152

Motor Full-load Current (Amp)	Thermal Unit Number
14.6-15.5	CC20.9
15.6-16.6	CC22.8
16.7-18.5	CC24.6
18.6-20.1	CC26.3
20.2-21.8	CC28.8
21.9-23.6	CC31.0
23.7-25.1	CC33.3
25.2-27.2	CC36.4
27.3-29.2	CC39.6
29.3-31.4	CC42.7
31.5-33.8	CC46.6
33.9-36.5	CC50.1
36.6-39.1	CC54.5
39.2-42.3	CC59.4

Table 153

Motor Full-load Current (Amp)	Thermal Unit Number
14.6-15.3	CC20.9
15.4-16.2	CC22.8
16.3-18.0	CC24.6
18.1-19.5	CC26.3
19.6-21.0	CC28.8
21.1-23.0	CC31.0
23.1-24.2	CC33.3
24.3-26.0	CC36.4
26.1-27.9	CC39.6
28.0-29.9	CC42.7
30.0-32.6	CC46.6
32.7-34.6	CC50.1
34.7-36.5	CC54.5
36.6-40.0	CC59.4



Square D Company
8001 Highway 64 East
Knightdale, NC 27545-9023
(919) 266-3671

INNOVA and ESP100 are registered trademarks of Furnas Electric Company.
ADVANTAGE is a registered trademark of Eaton Corporation.
MOTOR LOGIC is a trademark of Square D Company.
SERIPLEX, Square D and  are registered trademarks of Square D Company.

Catalog No. 9065CT9701 May 1998 © 1998 Square D All Rights Reserved.