

# Reduced Voltage Starters Type S

Class 8600



---

**SQUARE D**



# Class 8600 Reduced Voltage Starters Catalog Contents

## General Information

Introduction .....	2
Why use a reduced voltage starter? .....	2
Reduced voltage applications .....	3
Reduced voltage starting methods .....	3
Reduced voltage starter selection guide .....	5
Catalog number identification .....	6

## Autotransformer Starters

Starter description .....	7
Selection .....	8
Approximate dimensions & shipping weight .....	9

## Wye Delta Starters

Starter description .....	10
Selection .....	11
Approximate dimensions & shipping weight .....	12

## Part Winding Starters

Starter description .....	14
Selection .....	15
Approximate dimensions & shipping weight .....	16

## OEM Kits

Starter description .....	18
Selection .....	18

## Technical Specifications

Class 8606, 8630 & 8640 Starters .....	19
--	----



# Class 8600 Reduced Voltage Starters

## General Information

### Introduction

#### Introduction

The Class 8600 series of electromechanical reduced voltage starters are NEMA rated starters which provide the benefits of reduced current and torque. Class 8600 starters include Autotransformer, Wye Delta and Part Winding motor starters.

Class 8600 starters are UL listed to meet UL508 standards utilizing Type S devices. The Type S starter design sets the industry standard for ease of maintenance and reliability. Over 30 years of proven performance has made the Type S starter the most widely accepted family of NEMA rated starters ever produced.

Class 8600 starters provide comprehensive overload protection with a standard melting alloy overload relay. Solid state and bi-metallic motor thermal overload relays are also available.

Class 8600 starters are available in NEMA rated sizes 1 through 7 in various types of enclosures and as non-combination and combination devices.

#### Enclosed starters

Enclosed starters are available to meet environmental requirements for a wide variety of applications. Class 8600 starters are available in the following enclosure types:

- NEMA Type 1 General purpose
- NEMA Type 12 Dusttight and driptight
- NEMA Type 3R Rainproof
- NEMA Type 4 Watertight and corrosion resistant

#### Combination devices

Combination devices incorporate motor and branch circuit protection into one single, convenient package. Class 8600 starters may be ordered with factory installed disconnect means. Combination reduced voltage starters are available with fusing or circuit breakers. The following configurations are available as standard for the Class 8600 reduced voltage starter line:

Non-combination	Short circuit protection device mounted separately.
Fusible disconnect	Disconnect switch and fuse blocks provided which will accept the industry standard H, K or J fuse. Class R fuse clip kits can be factory or field installed to meet rejection fuse requirements.
Circuit breaker	Thermal magnetic circuit breakers are standard as nuisance tripping may occur during starter transition when using magnetic only circuit breakers.

#### Why use a reduced voltage starter?

A squirrel cage motor draws high starting current (inrush) and produces high starting torque when started at full voltage. High current draw during a full voltage start can cause the line voltage to sag which may adversely affect other equipment within the facility. The high torque developed during a full voltage start can cause excessive wear on the driven equipment or damage to material in process. A reduced voltage start reduces the negative effects of both high current inrush and torque.

#### Reduced current inrush

A typical squirrel cage induction motor started at full voltage will draw current from four to ten times the current required to run the motor at full speed, fully loaded. The current drawn during a full voltage start - or the locked rotor current - can cause negative effects on the distribution system. A motor started across the line can cause voltage drops which may cause lights to dim, or other equipment on the feeder circuit to slow down or drop out.

When reduced voltage is applied to a motor, the motor will draw current in proportion to the voltage reduction:

$$I_{rv} \approx I_{fv} \left\langle \frac{V_{rv}}{V_{fv}} \right\rangle$$

For a typical NEMA design B motor, the inrush or locked rotor current will be approximately 600% of the motor full load amperage (FLA) rating. If started with 65% of line voltage, the motor will then draw 0.65 x 600% or 390% FLA.

#### Reduced starting torque

When started at full voltage, a typical NEMA design B motor will produce approximately 150% of its rated torque. The torque produced by the motor in excess of the torque required by the driven load is used to accelerate the load from rest to full speed. Excess acceleration torque can cause mechanical shocks which can result in twisted shafts and couplings, excessive belt wear or early failure of moving parts in the driven equipment. If the motor accelerates too quickly, material in process can also be damaged during a full voltage start.

When a motor is started at reduced voltage, the torque is reduced by the square of the voltage reduction.

$$T_{rv} \approx T_{fv} \left\langle \frac{V_{rv}}{V_{fv}} \right\rangle^2$$

For example, if the NEMA B motor described above is started at 65% of line voltage, the torque developed would then be  $(0.65)^2$  or 42% of the normal starting torque.



# Class 8600 Reduced Voltage Starters General Information Reduced Voltage Applications

## Reduced voltage applications

Reduced voltage starters are used in a wide variety of applications. It is important to remember that an application that is difficult to start with full voltage will be even more difficult to start with reduced voltage. If the motor has a high inertia or if the motor rating is marginal for the applied load, reducing the starting torque may prevent the motor from reaching full speed before the thermal overloads trip. Applications that require high starting torque should be reviewed to determine if reduced voltage starting is suitable.

### Class 8606 - Autotransformer Starters

Autotransformer starters are the most widely used electromechanical reduced voltage starter. An Autotransformer starter may be used on any three phase AC motor and provides the maximum starting torque with the minimum starting current. Autotransformer starters are ideal for applications where available starting current is limited, but a minimal decrease in starting torque is required. Because the Autotransformer provides the highest torque efficiency, it is also ideal for applications which may be run from generator power. Typical applications for autotransformer starters include:

- Centrifugal pumps
- Fans
- Compressors
- Conveyors

### Class 8630 - Wye Delta Starters

Wye Delta starters are recommended for use on applications that require long start up time or frequent starts when using a wye delta motor. The Wye Delta starter is available in both open and closed transition configurations. The open transition starter is recommended for inertial loads while closed transition is best suited for frictional loading. Wye Delta starters can be applied in any application where low starting current is and low starting torque are necessary. Some typical applications include:

- Elevators
- Chillers
- Large air conditioning units
- Centrifuges

### Class 8640 - Part Winding Starters

Part Winding starters are recommended for use on applications that do not require long start up time or frequent starts. Part Winding starters are a cost effective means of providing a reduced voltage start where total line current draw is not of primary concern.

## Reduced voltage starting methods

A reduced voltage start may be achieved on a three phase squirrel cage motor by applying reduced voltage to the motor terminals. On Wye Delta or Part Winding motors, a reduced voltage start may be achieved by changing the connection of the motor windings while starting. Square D offers several types of electromechanical as well as solid state reduced voltage starters that provide different starting characteristics. The following describes the 8600 series of electromechanical reduced voltage starters.

### CLASS 8606 - Autotransformer Starter

Autotransformer starters provide reduced voltage to the motor terminals during starting through the use of a three phase autotransformer. Taps on the autotransformer allow for starting with 50%, 65% or 80% of line voltage. When connected to the 65% tap, the motor will draw 65% of the normal locked rotor current. The resulting starting torque will be  $(0.65)^2$  or 42% of the torque developed at full voltage. Because of the transformer action, the current draw on the line will be 42% of the current required at full voltage.

Since the motor current is higher than the line current, the Autotransformer starter allows for the most motor torque development with the minimum amount of line current required. The following table shows the torque efficiencies, as a percentage of full voltage values for each available Autotransformer tap:

RVAT Tap	Motor Starting Characteristics Compared to Full Voltage Starting		
	Line Current	Motor Current	Motor Torque
80%	64%	80%	64%
65%	42%	65%	42%
50%	25%	50%	25%

The Class 8606 starter is provided with closed transition from reduced to full voltage to avoid large transient currents seen in open transition starters where the motor is disconnected from the line supply during transition from start to run mode.

### CLASS 8630 - Wye Delta Starter

Wye Delta starters can only be used on wye delta motors which have six leads allowing for the motor windings to be connected in either a wye or delta configuration. During start up, the windings are connected in the wye configuration which results in 58% of line voltage applied across each winding. This reduces both inrush and starting torque to 33% of the delta connected values. After a set time delay the motor leads are switched to the delta connection for normal run operation. When using a wye delta starter, full voltage is applied to the motor terminals, but the effects of reduced voltage starting are the result of the way the windings are connected.

Wye delta starters are inherently open transition because the motor must be disconnected from the voltage supply in order to switch the windings from the wye to delta connection. Large voltage transients may occur when the motor is reconnected, depending on the phase angle of the line and load inertia. Closed transition starters may be supplied which use an additional contactor and resistor bank to keep the motor windings energized for a few cycles until the transition from wye to delta is complete.

When using a Wye Delta starter, in the delta connection the running current is shared between two contactors. As such, the thermal overloads for a wye delta starter must be sized for 58% of the motor rated current.



# **Class 8600 Reduced Voltage Starters**

## **General Information**

### **Reduced Voltage Starting Methods**

#### **CLASS 8640 - Part Winding Starter**

Part winding starters can only be used with part winding motors which have two sets of identical windings, intended to be operated in parallel. During a part winding start, only one winding is energized, reducing the inrush current to 60-70% (depending on the motor design) and starting torque to 50% of normal starting values with both windings energized. Most (but not all) dual voltage 230/460 volt motors are suitable for part winding starts at 230 volts.

The transition from reduced to full voltage must occur within a few seconds as neither winding is rated for continuous operation alone. With only one winding in the circuit, a typical part winding motor will not accelerate to more than half of the motor rated speed. Because the motor is operated with one winding only during the initial acceleration period, after the transition from start to run mode, the current draw of the motor may be close to the rated locked rotor amps. As such, a part winding starter provides a two step start, but does not necessarily reduce the peak current demand.

The initial winding is energized during both start and run modes. As such, the Class 8640 starter provides closed transition starting. Separate contactors are used to connect each winding. Per National Electrical Code (NEC), separate thermal overload protection is required for each winding. Six thermal units are required and should be sized for 50% of the motor rated current for use with part winding starters. If a factory installed disconnect means is requested, independent short circuit protection for each winding is supplied.

#### **Class 8638 - Solid State Reduced Voltage Starter**

Solid state reduced voltage starters provide smooth, stepless acceleration through electronic control of the applied voltage. By controlling the conduction of silicon controlled rectifiers (SCR's), the voltage is gradually ramped up to full voltage levels over an adjustable period of time providing a "soft start". The Altistart soft starts limit the peak current drawn during start up to an adjustable level to provide more flexibility and control of the motor starting characteristics. For more information on solid state starting, please refer to the Class 8638 Catalog or consult your local Square D Sales Office.



## Class 8600 Reduced Voltage Starters General Information Reduced Voltage Starter Selection Guide

### Reduced voltage starter selection guide

Selecting the best type of reduced voltage starter for your application depends primarily on the type of motor and desired starting performance. Typically, in lower horsepower applications, reduced voltage starters are used to provide a smooth acceleration. In higher horsepower applications where instantaneous demands for inrush current can get very high, reduced voltage starters are used to minimize the capacity requirements. The following table provides a comparison summary of the of reduced voltage starting methods offered by Square D Company.

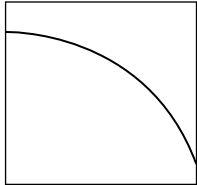
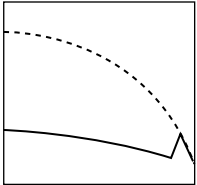
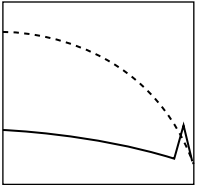
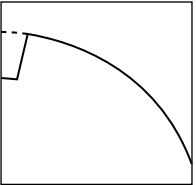
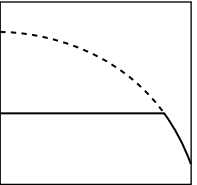
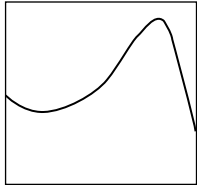
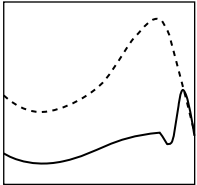
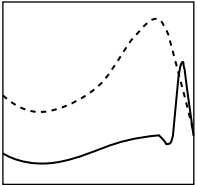
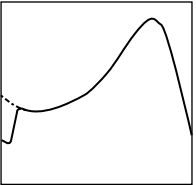
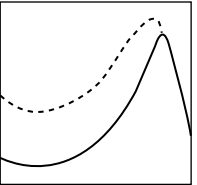
	Full Voltage	Autotransformer	Wye Delta	Part Winding	Solid State
Applied voltage at motor terminals	100%	50 / 65 / 80%	100%	100%	Ramped Up
Starting current % Full load current versus motor speed	600% 	150 / 250 / 380% 	200% 	390% 	200 - 500% 
Starting torque % Full load torque versus motor speed	150% 	40 / 60 / 100% 	50% 	70% 	16 - 105% 
Starting time	-	6 - 7 sec	10 - 15 sec	1 - 1.5 sec	2 - 30 sec
Summary of advantages	-Simple -Cost effective	-High torque/amp -Good for high inertia loads -Adjustable tap settings	-High torque/amp -Good for long acceleration times -Good for high inertia loads	-Simple -Small size	-Smooth, stepless acceleration -Flexible starting characteristics -Deceleration control available
Summary of disadvantages	-High current inrush -High starting torque -Abrupt start	-Large size -Limited duty cycle	-Low torque -No flexibility in starting characteristics	-Not suitable for High inertia loads or Frequent starts	-SCR heat dissipation -Ambient limitations -Sensitive to power quality
Type of motor	Standard	Standard	Special	Special	Standard



# Class 8600 Reduced Voltage Starters

## General Information

### Catalog Number Identification

#### Catalog number identification

A Class 8600 reduced voltage starter may be specified by Class, Type and Form. The Class indicates the style of starter, the Type indicates the rating and Forms may be used to customize the starter for specific needs. The Class 8600 starter catalog numbers may be interpreted as follows:

- **Square D Class number**

<b>Ex:</b>	<b>8606</b>
	8606 = Autotransformer Starter
	8630 = Wye Delta Starter - Open or Closed Transition
	8640 = Part Winding Starter

- **Type**

Ex:	SE	G	1	L		V81
	NEMA Size	Enclosure	Transition	Horsepower		Voltage Code (line/ control )
	SD = 2	A = NEMA 12	1 = Default (Class 8606 or 8640)	A=5	N=125	V08=208 / 208
	SE = 3	G = NEMA 1		B=7.5	O=150	V03=240 / 240
	SF = 4	K = OEM Kit		C=10	Q=200	V05=380 / 380
	SG = 5	O = Open		D=15	R=250	V06=480 / 480
	SH = 6	W = NEMA 4	1 = Open	F=25	T=400	V07=600 / 600
	SJ = 7		2 = Closed (Class 8630 Only)	G=30	U=500	V84=208 / 120*
				H=40	W=600	V82=240 / 24*
				J=50	X=700	V80=240 / 120*
				K=60	Y=800	V83=480 / 24*
				L=75	Z=1000	V81=480 / 120*
				M=100		V86=600 / 120*

\* If control voltage is different than line voltage, one of the control configurations forms listed below must be specified

- **Control configuration (Form)**

<b>Ex:</b>	<b>FF4T</b>
Description	Form
All coils at line voltage	Standard - No form required
Fused CPT for timing relay only	FF4T
Fused CPT for all coils	FF4T40
Separate control for timing relay	S
Separate control for all coils	Y195

We recommend using a control power transformer (CPT) to operate the timing relay at 120 Vac for the following reasons:

- If a separate source is used for the control circuit, there is a risk that following a line failure, the starter may not reset and the motor will start under full voltage. Using a CPT tied to the line voltage eliminates this risk.
- Supplying only the timing relay coil minimizes the size of the CPT required while providing operator interface a lower, safer voltage.

This configuration may be ordered by selecting the appropriate V8\* voltage code and the form FF4T.

- **Additional factory modifications**

<b>Ex:</b>	<b>A Y791</b>
Description	Form
Pilot Devices Start-Stop push buttons Hand-Off-Auto selector switch On-Off selector switch Red pilot light Green pilot light Amber pilot light	A C C6 P1 P2 P3
Disconnect Means Molded case circuit breaker Non-fusible disconnect switch Fusible disconnect switch	Y791 Y792 Y793 - Y799
Overload relays Motor Logic solid state overload with auxiliary contact Class 10 trip curve Class 20 trip curve Non-compensated bimetallic Type SC or SD (Size 1 or 2) Type SE or SF (Size 3 or 4) Type SG (Size 5) Type SH (Size 6) Ambient compensated bimetallic Type SC or SD (Size 1 or 2) Type SE or SF (Size 3 or 4) Type SG (Size 5) Type SH (Size 6)	(Not available on Class 8640 Starter Sizes 1 through 4) H11 H21 B2 B5 B2Y500 B2 B Y59 BY500 B
Meters Single phase ammeter Three phase ammeter Voltmeter Elapsed time meter Phase failure relay	G91 G93 G94 G97 G97 Y444

See the Square D digest for a complete listing of available factory modifications.

- **Sample Catalog Number**

8606SEG1LV81AFF4TY791

Description: NEMA Size 3 autotransformer starter rated for 50 HP at 480 Vac. Starter is provided in a NEMA Type 1 enclosure with a circuit breaker disconnect and fused CPT for 120 Vac control of the timing relay and start/stop push buttons.





# Class 8600 Reduced Voltage Starters Autotransformer Starters Starter Description

## Class 8606 Starter description

Class 8606 Autotransformer starters are provided with a NEMA rated medium duty autotransformer with taps to provide 50% , 65% or 80% of line voltage to start the motor. Three NEMA rated contactors (1S, 2S and RUN) and a pneumatic timing relay (TR) are required to achieve the start and run connections.

In the start mode, the 1S and 2S contactors are energized. The 1S contactor is energized from an instantaneous contact on the timing relay following a start command. A normally closed interlock on the 1S contactor then picks up the 2S coil making the connection across the autotransformer.

After a preset time delay, the timed contacts on TR change states and the 1S contactor drops out. With the 1S contactor open, the windings of the autotransformer temporarily act as a reactor through the 2S contactor.

After the 1S contactor has dropped out, the RUN contactor then closes. For maximum safety, the RUN and 1S contactors are mechanically and electrically interlocked. The RUN contactor then shorts out the autotransformer windings and the 2S contactor is dropped out.

### Sequence of operation

OPERATION	CONTACTOR		
	1S	2S	RUN
Start	X	X	
Transition		X	
Run			X

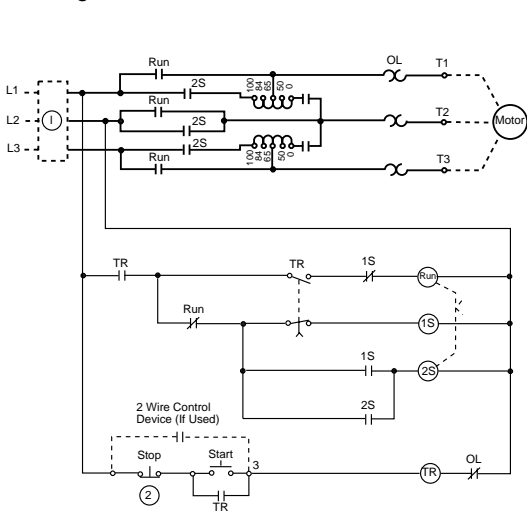

Size 2-5 Autotransformer starter with common control (standard)

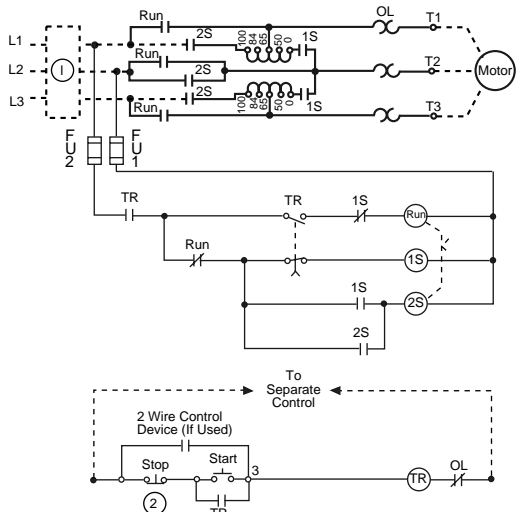

Size 2-5 Autotransformer starter with separate control (Form S)

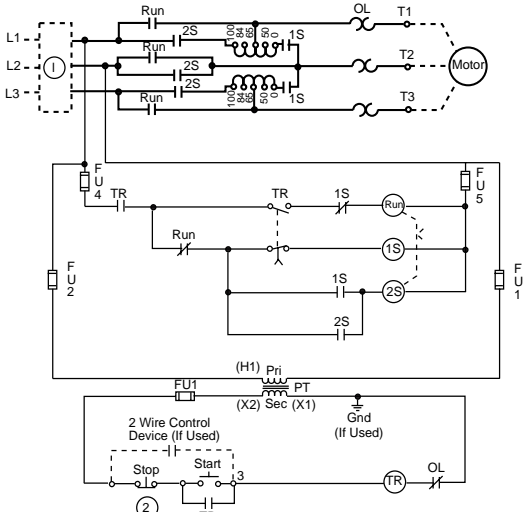

Size 2-5 Autotransformer starter with fused CPT (Form FF4T)

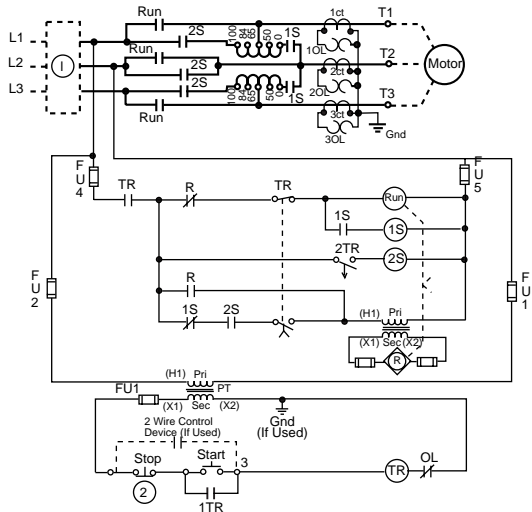

Size 6 Autotransformer starter (standard)

- ① Optional Disconnect means
- ② Optional Start/Stop control operators



**SQUARE D**

# Class 8600 Reduced Voltage Starters Autotransformer Starters Selection

## Class 8606 Selection

### 3 Pole Polyphase - 600 Volt Maximum - 50 / 60 Hz

Devices sizes 2 through 6 require 3 thermal units. Refer to Digest for thermal unit selection. Size 7 Starters are provided with the MOTOR LOGIC™ Solid State Overload as standard.

Rating			Enclosure				
Motor Voltage (Starter Voltage)	HP	NEMA Size	General Purpose Enclosure	Water tight and Dust tight Enclosure	Dust tight and Drip tight Industrial Use Enclosure	Open	O.E.M. Kit
			NEMA Type 1	NEMA Type 4	NEMA Type 12	Type	Type
200 (208)	10	2	SDG1C*	SDW1C	SDA1C*	SDO1C*	SDK1C*
	15 20 25	3	SEG1D* SEG1E* SEG1F*	SEW1D* SEW1E* SEW1F*	SEA1D* SEA1E* SEA1F*	SEO1D* SEO1E* SEO1F*	SEK1D* SEK1E* SEK1F*
	30 40	4	SFG1G* SFG1H*	SFW1G* SFW1H*	SFA1G* SFA1H*	SFO1G* SFO1H*	SFK1G* SFK1H*
	50 75	5	SGG1J* SGG1L*	SGW1J* SGW1L*	SGA1J* SGA1L*	SGO1J* SGO1L*	SGK1J* SGK1L*
	100 125 150	6	SHG1M* SHG1N* SHG1P*	SHW1M* SHW1N* SHW1P*	SHA1M* SHA1N* SHA1P*	SHO1M* SHO1N* SHO1P*	SHK1M* SHK1N* SHK1P*
230 (240)	10 15	2	SDG1C* SDG1D*	SDW1C* SDW1D*	SDA1C* SDA1D*	SDO1C* SDO1D*	SDK1C* SDK1D*
	20 25 30	3	SEG1E* SEG1F* SEG1G*	SEW1E* SEW1F* SEW1G*	SEA1E* SEA1F* SEA1G*	SEO1E* SEO1F* SEO1G*	SEK1E* SEK1F* SEK1G*
	40 50	4	SFG1H* SFG1J*	SFW1H* SFW1J*	SFA1H* SFA1J*	SFO1H* SFO1J*	SFK1H* SFK1J*
	75 100	5	SGG1L* SGG1M*	SGW1L* SGW1M*	SGA1L* SGA1M*	SGO1L* SGO1M*	SGK1L* SGK1M*
	125 150 200	6	SHG1N* SHG1P* SHG1Q*	SHW1N* SHW1P* SHW1Q*	SHA1N* SHA1P* SHA1Q*	SHO1N* SHO1P* SHO1Q*	SHK1N* SHK1P* SHK1Q*
	250 300	7	SJG1R* SJG1S*	SJW1R* SJW1S*	SJA1R* SJA1S*	-	-
460 / 575 (480 / 600)	10 15 20 25	2	SDG1C* SDG1D* SDG1E* SDG1F*	SDW1C* SDW1D* SDW1E* SDW1F*	SDA1C* SDA1D* SDA1E* SDA1F*	SDO1C* SDO1D* SDO1E* SDO1F*	SDK1C* SDK1D* SDK1E* SDK1F*
	30 40 50	3	SEG1G* SEG1H* SEG1J*	SEW1G* SEW1H* SEW1J*	SEA1G* SEA1H* SEA1J*	SEO1G* SEO1H* SEO1J*	SEK1G* SEK1H* SEK1J*
	75 100	4	SFG1L* SFG1M*	SFW1L* SFW1M*	SFA1L* SFA1M*	SFO1L* SFO1M*	SFK1L* SFK1M*
	125 150 200	5	SGG1N* SGG1P* SGG1Q*	SGW1N* SGW1P* SGW1Q*	SGA1N* SGA1P* SGA1Q*	SGO1N* SGO1P* SGO1Q*	SGK1N* SGK1P* SGK1Q*
	250 300 400	6	SHG1R* SHG1S* SHG1T*	SHW1R* SHW1S* SHW1T*	SHA1R* SHA1S* SHA1T*	SHO1R* SHO1S* SHO1T*	SHK1R* SHK1S* SHK1T*
	500 600	7	SJG1U* SJG1W*	SJW1U* SJW1W*	SJA1U* SJA1W*	-	-

\* Complete catalog number includes Class, Type, Voltage Code and Form(s). Refer to page 6 for standard voltage and control configurations available.

NEMA Type 4 enclosures are painted sheet steel. Where required, stainless steel enclosures are available at extra cost.



# Class 8600 Reduced Voltage Starters Autotransformer Starters Dimensions and Weight

## Class 8606

### Approximate dimensions & shipping weight

Dual dimensions provided in inches and millimeters are approximate. Not for construction purposes.

NEMA Size	Enclosure Type	Disconnect*	Dual Dimensions inches (millimeters)											Enclosure Style	Approx. Shipping Weight (lbs)	
			A width	B height	C depth	D	E	F	G	H	I	J	K		Non Combo	Combo
2	1, 4, 12	NC/CB/DS	25.00 (635)	50.00 (1270)	9.38 (238)	19.00 (483)	51.50 (1308)	3.00 (76)	0.50 (13)	1.18 (30)	2.00 (51)	0.44 (11)	0.25 (6)	1	250	290
3 4 5	1, 12	NC/CB/DS	32.00 (813)	70.00 (1778)	16.00 (406)	29.75 (756)	12.50 (318)	1.13 (29)	1.13 (29)	2.50 (64)	3.25 (83)	0.69 (18)	-	2	490 560 635	530 600 675
3 4 5	4	NC/CB/DS	32.00 (813)	75.00 (1905)	16.00 (406)	30.00 (762)	9.00 (229)	1.00 (25)	2.89 (73)	2.50 (64)	3.25 (83)	0.69 (18)	-	2	490 560 635	530 600 675
5	1, 12	DS (Y797)	36.00 (914)	90.00 (2286)	16.00 (406)	33.75 (857)	12.50 (318)	1.13 (29)	1.13 (29)	2.50 (64)	3.25 (83)	0.69 (18)	-	2	-	675
5	4	DS (Y797)	36.00 (914)	95.00 (2413)	16.00 (406)	34.00 (864)	9.00 (229)	1.00 (25)	2.89 (73)	2.50 (64)	3.25 (83)	0.69 (18)	-	5	-	675
6 7	1, 12	NC/CB	34.00 (864)	90.00 (2286)	20.00 (508)	31.75 (806)	16.50 (419)	1.13 (29)	1.13 (29)	3.38 (86)	3.25 (83)	0.69 (18)	-	2	1070 1770	1110 1810
6	4	NC/CB	34.00 (864)	98.00 (2489)	20.00 (508)	32.00 (813)	13.00 (330)	1.00 (25)	3.00 (76)	3.38 (86)	3.25 (83)	0.69 (18)	-	5	1070	1110
6 7	1, 12	DS	64.00 (1626)	90.00 (2286)	24.00 (609)	61.75 (1568)	17.25 (438)	1.13 (29)	4.38 (111)	3.38 (86)	3.25 (83)	0.81 (21)	-	3	-	1110 1810

\* Disconnect Options:

NC = Non-combination - standard

CB = Factory installed circuit breaker - form Y791

DS = Factory installed disconnect switch - fusible or non fusible - form Y792 through Y798

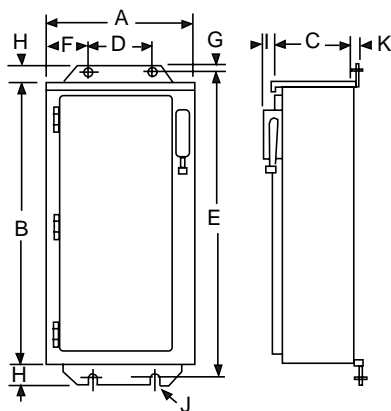

Enclosure Style 1

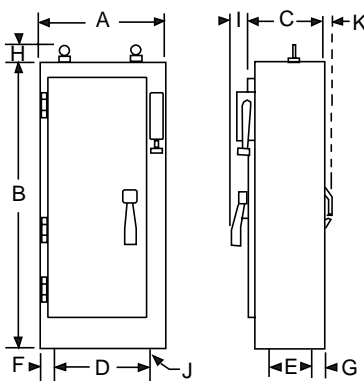

Enclosure Style 2

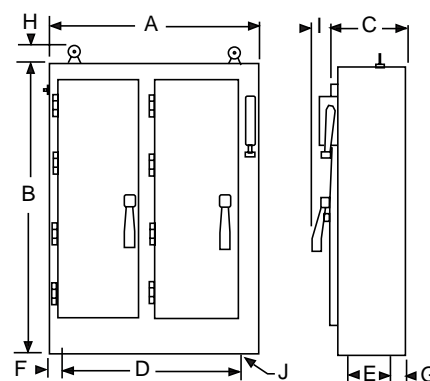

Enclosure Style 3



# Class 8600 Reduced Voltage Starters

## Wye Delta Starters

### Starter Description

#### Class 8630 Starter description

Open transition Wye Delta starters are supplied with three NEMA rated contactors (1M, 2M and 1S) and a pneumatic timing relay (TR). The 1M and 1S contactors close upon a start command to connect the motor leads into the wye connection. The 1S contactor connects terminals T4, T5 & T6 creating the Y formation. The 1M contactor then connects the motor to the line supply for reduced voltage starting. After the preset time delay, the timing relay then signals the 1S contactor to drop out. At this point there is no current flowing to the motor.

After the 1S contactor has dropped out, the 2M contactor picks up. With the 1M contactor still energized, the 2M contactor completes the motor connection in the delta configuration. The 2M and 1S contactors are both mechanically and electrically interlocked to prevent a line to line short per NEMA standards.

In order to maintain current flow to the motor during the transition from wye to delta, closed transition starters are available which have an additional contactor (2S) and 3-phase resistor bank. The resistors are sized to match the motor winding impedance so that current flow may be maintained during the brief period after the 1S contactor drops out until the 2M contactor picks up.

#### Sequence of operation

Open Transition	CONTACTOR			Closed Transition	Contactor			
	1S	1M	2M		OPERATION	1S	2S	1M
Start	X	X		Start	X		X	
Transition		X		Transition 1	X	X	X	
Run		X	X	Transition 2		X	X	
				Run			X	X

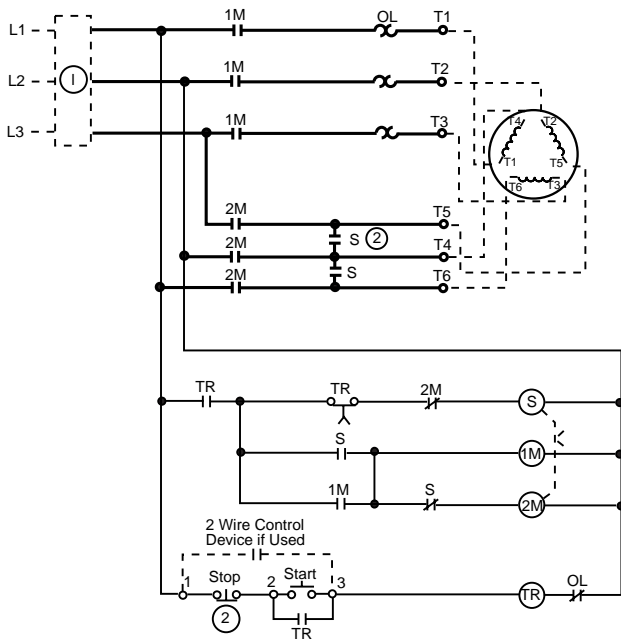

Size 1YD - 5YD Open Transition Wye Delta Starter

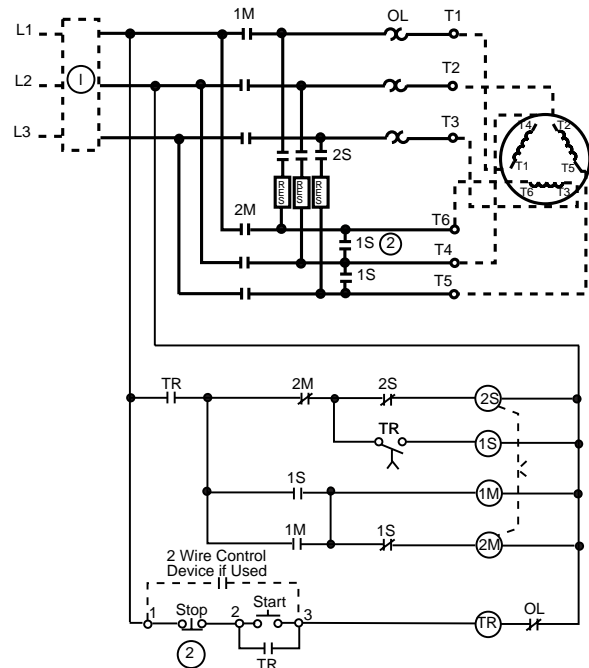

Size 1YD - 5YD Closed Transition Wye Delta Starter

- ① Optional Disconnect means
- ② Optional Start/Stop control operators



# Class 8600 Reduced Voltage Starters Wye Delta Starters Selection

## Class 8630 Selection

### 3 Pole Polyphase - 600 Volt Maximum - 50 / 60 Hz

Devices sizes 1 through 6 require 3 thermal units sized for 58% of the motor FLA rating. Refer to Digest for selection. Size 7 Starters are provided with the MOTOR LOGIC™ Solid State Overload as standard.

Rating			Enclosure									
Motor Voltage (Starter Voltage)	HP	NEMA Size	General Purpose Enclosure		Water tight and Dust tight Enclosure		Dust tight and Drip tight Industrial Use Enclosure		Open Type		O.E.M. Kit	
			NEMA Type 1		NEMA Type 4		NEMA Type 12		Type		Type	
			Open Transition	Closed Transition	Open Transition	Closed Transition	Open Transition	Closed Transition	Open Transition	Closed Transition	Open Transition	Closed Transition
200 (208)	10	1YD	SCG1C*	SCG2C*	SCW1C*	SCW2C*	SCA1C*	SCA2C*	SCO1C*	SCO2C*	-	-
	15 20	2YD	SDG1D* SDG1E*	SDG2D* SDG2E*	SDW1D* SDW1E*	SDW2D* SDW2E*	SDA1D* SDA1E*	SDA2D* SDA2E*	SDO1D* SDO1E*	SDO2D* SDO2E*	-	-
	25 30 40	3YD	SEG1F* SEG1G* SEG1H*	SEG2F* SEG2G* SEG2H*	SEW1F* SEW1G* SEW1H*	SEW2F* SEW2G* SEW2H*	SEA1F* SEA1G* SEA1H*	SEA2F* SEA2G* SEA2H*	SEO1F* SEO1G* SEO1H*	SEO2F* SEO2G* SEO2H*	SEK1F* SEK1G* SEK1H*	SEK2F* SEK2G* SEK2H*
	50 60	4YD	SFG1J* SFG1K*	SFG2J* SFG2K*	SFW1J* SFW1K*	SFW2J* SFW2K*	SFA1J* SFA1K*	SFA2J* SFA2K*	SFO1J* SFO1K*	SFO2J* SFO2K*	SFK1J* SFK1K*	SFK2J* SFK2K*
	75 100 125 150	5YD	SGG1L* SGG1M* SGG1N* SGG1P*	SGG2L* SGG2M* SGG2N* SGG2P*	SGW1L* SGW1M* SGW1N* SGW1P*	SGW2L* SGW2M* SGW2N* SGW2P*	SGA1L* SGA1M* SGA1N* SGA1P*	SGA2L* SGA2M* SGA2N* SGA2P*	SGO1L* SGO1M* SGO1N* SGO1P*	SGO2L* SGO2M* SGO2N* SGO2P*	SGK1L* SGK1M* SGK1N* SGK1P*	SGK2L* SGK2M* SGK2N* SGK2P*
	200 250 300	6YD	SHG1Q* SHG1R* SHG1S*	SHG2Q* SHG2R* SHG2S*	SHW1Q* SHW1R* SHW1S*	SHW2Q* SHW2R* SHW2S*	SHA1Q* SHA1R* SHA1S*	SHA2Q* SHA2R* SHA2S*	SHO1Q* SHO1R* SHO1S*	SHO2Q* SHO2R* SHO2S*	SHK1Q* SHK1R* SHK1S*	SHK2Q* SHK2R* SHK2S*
230 (240)	10	1YD	SCG1C*	SCG2C*	SCW1C*	SCW2C*	SCA1C*	SCA2C*	SCO1C*	SCO2C*	-	-
	15 20 25	2YD	SDG1D* SDG1E* SDG1F*	SDG2D* SDG2E* SDG2F*	SDW1D* SDW1E* SDW1F*	SDW2D* SDW2E* SDW2F*	SDA1D* SDA1E* SDA1F*	SDA2D* SDA2E* SDA2F*	SDO1D* SDO1E* SDO1F*	SDO2D* SDO2E* SDO2F*	-	-
	30 40 50	3YD	SEG1G* SEG1H* SEG1J*	SEG2G* SEG2H* SEG2J*	SEW1G* SEW1H* SEW1J*	SEW2G* SEW2H* SEW2J*	SEA1G* SEA1H* SEA1J*	SEA2G* SEA2H* SEA2J*	SEO1G* SEO1H* SEO1J*	SEO2G* SEO2H* SEO2J*	SEK1G* SEK1H* SEK1J*	SEK2G* SEK2H* SEK2J*
	60 75	4YD	SFG1K* SFG1L*	SFG2K* SFG2L*	SFW1K* SFW1L*	SFW2K* SFW2L*	SFA1K* SFA1L*	SFA2K* SFA2L*	SFO1K* SFO1L*	SFO2K* SFO2L*	SFK1K* SFK1L*	SFK2K* SFK2L*
	100 125 150	5YD	SGG1M* SGG1N* SGG1P*	SGG2M* SGG2N* SGG2P*	SGW1M* SGW1N* SGW1P*	SGW2M* SGW2N* SGW2P*	SGA1M* SGA1N* SGA1P*	SGA2M* SGA2N* SGA2P*	SGO1M* SGO1N* SGO1P*	SGO2M* SGO2N* SGO2P*	SGK1M* SGK1N* SGK1P*	SGK2M* SGK2N* SGK2P*
	200 250 300	6YD	SHG1Q* SHG1R* SHG1S*	SHG2Q* SHG2R* SHG2S*	SHW1Q* SHW1R* SHW1S*	SHW2Q* SHW2R* SHW2S*	SHA1Q* SHA1R* SHA1S*	SHA2Q* SHA2R* SHA2S*	SHO1Q* SHO1R* SHO1S*	SHO2Q* SHO2R* SHO2S*	SHK1Q* SHK1R* SHK1S*	SHK2Q* SHK2R* SHK2S*
	400 500	7YD	SJG1T* SJG1U*	SJG2T* SJG2U*	SJW1T* SJW1U*	SJW2T* SJW2U*	SJA1T* SJA1U*	JA2T* SJA2U*	SJO1T* SJO1U*	SJO2T* SJO2U*	-	-
460 / 575 (480 / 600)	10 15	1YD	SCG1C* SCG1D*	SCG2C* SCG2D*	SCW1C* SCW1D*	SCW2C* SCW2D*	SCA1C* SCA1D*	SCA2C* SCA2D*	SCO1C* SCO1D*	SCO2C* SCO2D*	-	-
	20 25 30 40	2YD	SDG1E* SDG1F* SDG1G* SDG1H*	SDG2E* SDG2F* SDG2G* SDG2H*	SDW1E* SDW1F* SDW1G* SDW1H*	SDW2E* SDW2F* SDW2G* SDW2H*	SDA1E* SDA1F* SDA1G* SDA1H*	SDA2E* SDA2F* SDA2G* SDA2H*	SDO1E* SDO1F* SDO1G* SDO1H*	SDO2E* SDO2F* SDO2G* SDO2H*	-	-
	50 60 75	3YD	SEG1J* SEG1K* SEG1L*	SEG2J* SEG2K* SEG2L*	SEW1J* SEW1K* SEW1L*	SEW2J* SEW2K* SEW2L*	SEA1J* SEA1K* SEA1L*	SEA2J* SEA2K* SEA2L*	SEO1J* SEO1K* SEO1L*	SEO2J* SEO2K* SEO2L*	SEK1J* SEK1K* SEK1L*	SEK2J* SEK2K* SEK2L*
	100 125 150	4YD	SFG1M* SFG1N* SFG1P*	SFG2M* SFG2N* SFG2P*	SFW1M* SFW1N* SFW1P*	SFW2M* SFW2N* SFW2P*	SFA1M* SFA1N* SFA1P*	SFA2M* SFA2N* SFA2P*	SFO1M* SFO1N* SFO1P*	SFO2M* SFO2N* SFO2P*	SFK1M* SFK1N* SFK1P*	SFK2M* SFK2N* SFK2P*
	200 250 300	5YD	SGG1Q* SGG1R* SGG1S*	SGG2Q* SGG2R* SGG2S*	SGW1Q* SGW1R* SGW1S*	SGW2Q* SGW2R* SGW2S*	SGA1Q* SGA1R* SGA1S*	SGA2Q* SGA2R* SGA2S*	SGO1Q* SGO1R* SGO1S*	SGO2Q* SGO2R* SGO2S*	SGK1Q* SGK1R* SGK1S*	SGK2Q* SGK2R* SGK2S*
	400 500 600	6YD	SHG1T* SHG1U* SHG1W*	SHG2T* SHG2U* SHG2W*	SHW1T* SHW1U* SHW1W*	SHW2T* SHW2U* SHW2W*	SHA1T* SHA1U* SHA1W*	SHA2T* SHA2U* SHA2W*	SHO1T* SHO1U* SHO1W*	SHO2T* SHO2U* SHO2W*	SHK1T* SHK1U* SHK1W*	SHK2T* SHK2U* SHK2W*
	800 1000	7YD	SJG1Y* SJG1Z*	SJG2Y* SJG2Z*	SJW1Y* SJW1Z*	SJW2Y* SJW2Z*	SJA1Y* SJA1Z*	SJA2Y* SJA2Z*	SJO1Y* SJO1Z*	SJO2Y* SJO2Z*	-	-

\* Complete catalog number includes Class, Type, Voltage Code and Form(s). Refer to page 6 for standard voltage and control configurations available.

NEMA Type 4 enclosures are painted sheet steel. Where required, stainless steel enclosures are available at extra cost.



# Class 8600 Reduced Voltage Starters Wye Delta Starters Dimensions and Weight

## Class 8630

### Approximate dimensions & shipping weight

Dual dimensions provided in inches and millimeters are approximate. Not for construction purposes.

NEMA Size	Enclosure Type	Disconnect *	Dual Dimensions Inches (Millimeters)											Enclosure Style	Approx. Shipping Weight (lbs)	
			A width	B height	C depth	D	E	F	G	H	I	J	K		Non Combo	Combo
<b>Open Transition Starters</b>																
1YD or 2YD	1	NC CB DS	23.00 (584)	24.50 (622)	8.25 (210)	20.50 (521)	22.00 (559)	1.25 (32)	1.25 (32)	0.25 (6)	2.10 (53)	0.44 (11)	0.25 (6)	4	90 100	130 140
1YD or 2YD	12	NC CB DS	23.00 (584)	23.00 (584)	8.50 (216)	17.00 (432)	24.50 (622)	3.00 (76)	0.50 (13)	1.25 (32)	2.00 (51)	0.44 (11)	0.25 (6)	1	90 100	130 140
1YD or 2YD	4	NC	23.00 (584)	23.00 (584)	8.25 (210)	17.00 (432)	24.50 (622)	7.50 (191)	0.50 (13)	1.25 (32)	-	0.56 (14)	0.25 (6)	1	90 100	- -
3YD or 4YD	1	NC	28.25 (718)	45.50 (1156)	8.25 (210)	15.00 (381)	47.50 (1207)	6.63 (168)	0.50 (13)	1.50 (38)	-	0.56 (14)	0.25 (6)	1	220 235	- -
3YD or 4YD	12, 4	NC	28.25 (718)	45.50 (1156)	8.25 (210)	20.25 (514)	47.50 (1207)	4.00 (102)	0.50 (13)	1.50 (38)	-	0.56 (14)	0.25 (6)	1	220 235	- -
3YD or 4YD	1	CB DS	30.00 (762)	47.00 (1194)	10.63 (270)	15.00 (381)	49.00 (1245)	7.50 (191)	0.50 (13)	1.50 (38)	1.75 (44)	0.56 (14)	0.25 (6)	1	- -	260 275
3YD or 4YD	12, 4	CB DS	30.00 (762)	47.00 (1194)	10.63 (270)	22.00 (559)	49.00 (1245)	4.00 (102)	0.50 (13)	1.50 (38)	1.75 (44)	0.56 (14)	0.25 (6)	1	- -	260 275
5YD or 6YD	1, 12	NC CB	36.00 (914)	90.00 (2286)	16.00 (406)	33.75 (857)	12.50 (318)	1.13 (29)	1.13 (29)	2.50 (64)	3.25 (83)	0.69 (18)	-	2	425 750	465 790
5YD or 6YD	4	NC CB	36.00 (914)	98.00 (2489)	16.00 (406)	34.00 (864)	9.00 (229)	1.00 (25)	3.00 (76)	2.50 (64)	3.25 (83)	0.69 (18)	-	5	425 750	465 790
<b>Closed Transition Starters</b>																
1YD or 2YD	1	NC CB DS	23.25 (591)	23.25 (591)	16.00 (406)	17.25 (438)	24.75 (629)	3.00 (76)	0.50 (13)	1.25 (32)	1.75 (44)	0.44 (11)	0.25 (6)	1	125 135	165 175
1YD or 2YD	12	NC CB DS	23.25 (591)	23.25 (591)	16.00 (406)	17.25 (438)	24.75 (629)	3.00 (76)	0.50 (13)	1.25 (32)	1.75 (44)	0.44 (11)	0.25 (6)	1	125 135	165 175
1YD or 2YD	4	NC CB DS	23.25 (591)	23.25 (591)	16.00 (406)	17.25 (438)	24.75 (629)	3.00 (76)	0.50 (13)	1.25 (32)	-	0.44 (11)	0.25 (6)	1	125 135	165 175
3YD or 4YD	1	NC	28.25 (718)	45.50 (1156)	15.25 (387)	20.25 (514)	47.50 (1207)	4.00 (102)	0.50 (13)	1.50 (38)	-	0.56 (14)	0.25 (6)	1	265 280	- -
3YD or 4YD	1	CB DS	30.00 (762)	47.00 (1194)	18.13 (461)	15.00 (381)	49.00 (1245)	7.50 (191)	0.50 (13)	1.50 (38)	1.75 (44)	0.56 (14)	0.25 (6)	1	- -	305 320
3YD or 4YD	12, 4	NC	28.25 (718)	45.50 (1156)	15.25 (387)	20.25 (514)	47.50 (1207)	4.00 (102)	0.50 (13)	1.50 (38)	-	0.56 (14)	0.25 (6)	1	265 280	- -
3YD or 4YD	12, 4	CB DS	30.00 (762)	47.00 (1194)	18.13 (461)	22.00 (559)	49.00 (1245)	4.00 (102)	0.50 (13)	1.50 (38)	1.75 (44)	0.56 (14)	0.25 (6)	1	- -	305 320
5YD or 6YD	1, 12	NC CB	36.00 (914)	90.00 (2286)	16.00 (406)	33.75 (857)	12.50 (318)	1.13 (29)	1.13 (29)	2.50 (64)	3.25 (83)	0.69 (18)	-	2	470 840	510 880
5YD or 6YD	4	NC CB	36.00 (914)	98.00 (2489)	16.00 (406)	34.00 (864)	9.00 (229)	1.00 (25)	3.00 (76)	2.50 (64)	3.25 (83)	0.69 (18)	-	5	470 840	510 880

\* Free Standing Enclosure

• Disconnect Options:

NC = Non-combination - standard

CB = Factory installed circuit breaker - form Y791

DS = Factory installed disconnect switch - fusible or nonfusible - form Y792 through Y798



**Class 8600 Reduced Voltage Starters  
Wye Delta Starters  
Dimensions and Weight**

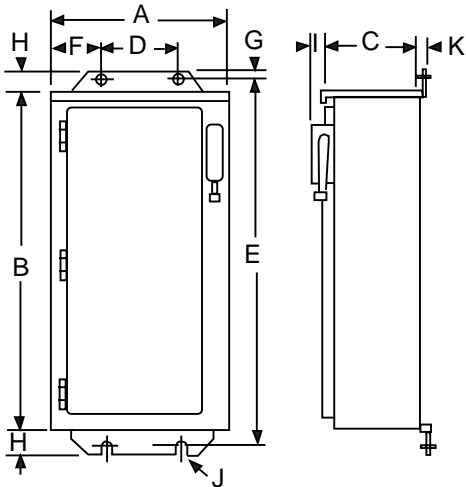

Enclosure Style 1

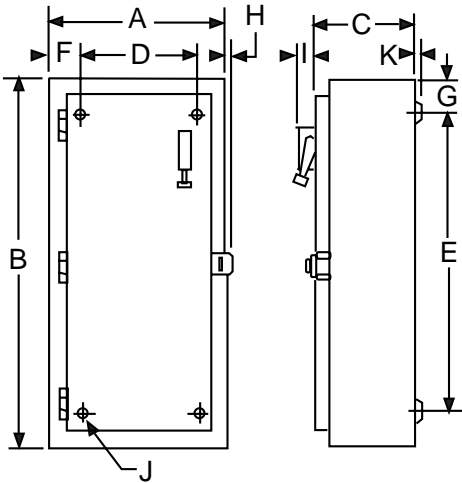

Enclosure Style 4

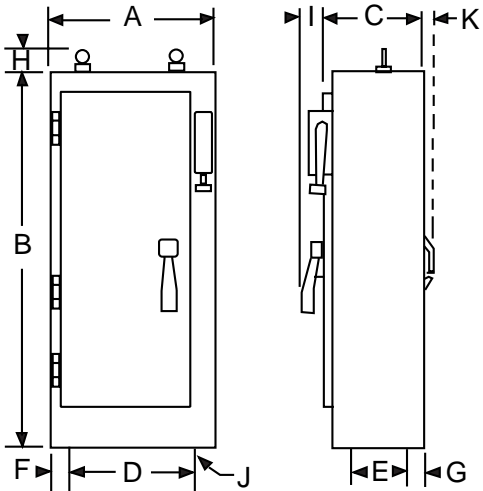

Enclosure Style 2

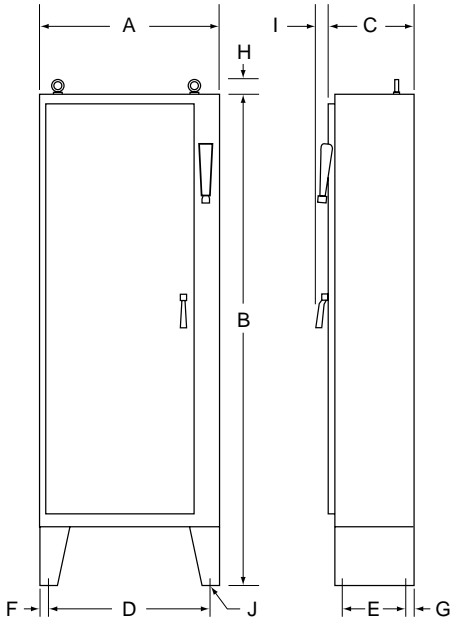

Enclosure Style 5







# Class 8600 Reduced Voltage Starters Part Winding Starters Selection

## Class 8640 Selection

### 3 Phase - 600 Volt Maximum - 50 / 60 Hz

Devices sizes 1 through 6 require 6 thermal units sized for 50% of motor full load amp rating. Size 7 Starters are provided with the MOTOR LOGIC™ Solid State Overload as standard.

Max Horsepower Rating			Enclosure				
Motor Voltage (Starter Voltage)	HP	NEMA Size	General Purpose Enclosure NEMA Type 1	Water tight and Dust tight Enclosure NEMA Type 4	Dust tight and Drip tight Industrial Use Enclosure NEMA Type 12	Open Type Type	O.E.M. Kit Type
200 (208)	10	1PW	SCG1C*	SCW1C*	SCA1C*	SCO1C*	-
	15 20	2PW	SDG1D* SDG1E*	SDW1D* SDW1E*	SDA1D* SDA1E*	SDO1D* SDO1E*	SDK1D* SDK1E*
	25 30 40	3PW	SEG1F* SEG1G* SEG1H*	SEW1F* SEW1G* SEW1H*	SEA1F* SEA1G* SEA1H*	SEO1F* SEO1G* SEO1H*	SEK1F* SEK1G* SEK1H*
	50 60 75	4PW	SFG1J* SFG1K* SFG1L*	SFW1J* SFW1K* SFW1L*	SFA1J* SFA1K* SFA1L*	SFO1J* SFO1K* SFO1L*	SFK1J* SFK1K* SFK1L*
	100 125 150	5PW	SGG1M* SGG1N* SGG1P*	SGW1M* SGW1N* SGW1P*	SGA1M* SGA1N* SGA1P*	SGO1M* SGO1N* SGO1P*	SGK1M* SGK1N* SGK1P*
230 (240)	10	1PW	SCG1C*	SCW1C*	SCA1C*	SCO1C*	-
	15 20 25	2PW	SDG1D* SDG1E* SDG1F*	SDW1D* SDW1E* SDW1F*	SDA1D* SDA1E* SDA1F*	SDO1D* SDO1E* SDO1F*	SDK1D* SDK1E* SDK1F*
	30 40 50	3PW	SEG1G* SEG1H* SEG1J*	SEW1G* SEW1H* SEW1J*	SEA1G* SEA1H* SEA1J*	SEO1G* SEO1H* SEO1J*	SEK1G* SEK1H* SEK1J*
	60 75	4PW	SFG1K* SFG1L*	SFW1K* SFW1L*	SFA1K* SFA1L*	SFO1K* SFO1L*	SFK1K* SFK1L*
	100 125 150	5PW	SGG1M* SGG1N* SGG1P*	SGW1M* SGW1N* SGW1P*	SGA1M* SGA1N* SGA1P*	SGO1M* SGO1N* SGO1P*	SGK1M* SGK1N* SGK1P*
	200 250 300	6PW	SHG1Q* SHG1R* SHG1S*	SHW1Q* SHW1R* SHW1S*	SHA1Q* SHA1R* SHA1S*	SHO1Q* SHO1R* SHO1S*	-
	400	7PW	SJG1T*	SJW1T*	SJA1T*	SJO1T*	-
460 / 575 (480 / 600)	10 15	1PW	SCG1C* SCG1D*	SCW1C* SCW1D*	SCA1C* SCA1D*	SCO1C* SCO1D*	-
	20 25 30 40	2PW	SDG1E* SDG1F* SDG1G* SDG1H*	SDW1E* SDW1F* SDW1G* SDW1H*	SDA1E* SDA1F* SDA1G* SDA1H*	SDO1E* SDO1F* SDO1G* SDO1H*	SDK1E* SDK1F* SDK1G* SDK1H*
	50 60 75	3PW	SEG1J* SEG1K* SEG1L*	SEW1J* SEW1K* SEW1L*	SEA1J* SEA1K* SEA1L*	SEO1J* SEO1K* SEO1L*	SEK1J* SEK1K* SEK1L*
	100 125 150	4PW	SFG1M* SFG1N* SFG1P*	SFW1M* SFW1N* SFW1P*	SFA1M* SFA1N* SFA1P*	SFO1M* SFO1N* SFO1P*	SFK1M* SFK1N* SFK1P*
	200 250 300	5PW	SGG1Q* SGG1R* SGG1S*	SGW1Q* SGW1R* SGW1S*	SGA1Q* SGA1R* SGA1S*	SGO1Q* SGO1R* SGO1S*	SGK1Q* SGK1R* SGK1S*
	400 500 600	6PW	SHG1T* SHG1U* SHG1W*	SHW1T* SHW1U* SHW1W*	SHA1T* SHA1U* SHA1W*	SHO1T* SHO1U* SHO1W*	-
	700 800	7PW	SJG1X* SJG1Y*	SJW1X* SJW1Y*	SJA1X* SJA1Y*	SJO1X* SJO1Y*	-

\* Complete catalog number includes Class, Type, Voltage Code and Form(s). Refer to page 6 for standard voltage and control configurations available.

NEMA Type 4 enclosures are painted sheet steel. Where required, stainless steel enclosures are available at extra cost. Consult your local Square D sales office for price adder.



# Class 8600 Reduced Voltage Starters Part Winding Starters Dimensions and Weight

## Class 8640

### Approximate dimensions & shipping weight

Dual dimensions provided in inches and millimeters are approximate. Not for construction purposes.

NEMA Size	Enclosure Type	Disconnect *	Dual Dimensions Inches (Millimeters)											Enclosure Style	Approx. Shipping Weight (lbs)
			A width	B height	C depth	D	E	F	G	H	I	J	K		
1PW or 2PW	1	NC	23.00 (584)	24.50 (622)	8.50 (216)	20.50 (521)	22.00 (559)	1.25 (32)	1.25 (32)	0.25 (6)	0.88 (22)	0.44 (11)	.31 (8)	-	80 100
1PW or 2PW	12, 4	NC	23.00 (584)	23.00 (584)	8.50 (216)	17.00 (432)	24.50 (622)	3.00 (76)	0.50 (13)	1.18 (30)	-	0.44 (11)	0.25 (6)	1	80 100
1PW or 2PW	12	DS	23.00 (584)	23.00 (584)	8.50 (216)	17.00 (432)	24.50 (622)	3.00 (76)	0.50 (13)	1.25 (32)	2.00 (51)	0.44 (11)	0.25 (6)	1	120 140
1PW or 2PW	1	CB	19.00 (483)	32.00 (813)	10.50 (267)	15.63 (397)	29.50 (749)	1.69 (43)	1.25 (32)	0.31 (8)	1.25 (32)	0.44 (11)	-	-	120 140
1PW or 2PW	12	CB	19.00 (483)	32.00 (813)	10.50 (267)	13.25 (337)	33.50 (851)	3.00 (76)	0.50 (13)	1.25 (32)	1.25 (32)	0.44 (11)	0.25 (6)	1	120 140
3PW or 4PW	1	NC	28.25 (718)	45.50 (1156)	8.25 (210)	15.00 (381)	47.50 (1207)	6.63 (168)	0.50 (13)	1.50 (38)	-	0.56 (14)	0.25 (6)	1	205 215
3PW or 4PW	12, 4	NC	28.25 (718)	45.50 (1156)	8.25 (210)	20.25 (514)	47.50 (1207)	4.00 (102)	0.50 (13)	1.50 (38)	-	0.56 (14)	0.25 (6)	1	205 215
3PW or 4PW	1	CB	30.00 (762)	44.00 (1118)	11.50 (292)	15.00 (381)	46.00 (1168)	7.50 (191)	0.50 (13)	1.50 (38)	-	0.56 (14)	0.25 (6)	1	245 255
3PW or 4PW	12	CB	30.00 (762)	44.00 (1118)	11.75 (298)	22.00 (559)	46.00 (1168)	4.00 (102)	0.50 (13)	1.50 (38)	1.25 (32)	0.56 (14)	0.25 (6)	1	245 255
3PW	1	DS	25.00 (635)	50.00 (1270)	10.38 (264)	19.00 (483)	51.50 (1308)	3.00 (76)	0.50 (13)	1.25 (32)	-	0.44 (11)	0.25 (6)	1	245
3PW	12	DS	25.00 (635)	50.00 (1270)	10.78 (274)	19.00 (483)	51.50 (1308)	3.00 (76)	0.50 (13)	1.25 (32)	1.75 (44)	0.44 (11)	0.25 (6)	1	245
4PW	1	DS	36.00 (914)	90.00 (2286)	16.00 (406)	33.75 (857)	12.50 (318)	1.25 (32)	1.25 (32)	2.50 (64)	3.25 (83)	0.69 (18)	-	2	255
4PW	4	DS	36.00 (914)	95.00 (2413)	16.00 (406)	34.00 (864)	9.00 (229)	1.00 (25)	3.00 (76)	2.50 (64)	3.25 (83)	0.69 (18)	-	-	255
5PW	1	NC	24.00 (610)	42.00 (1067)	12.00 (305)	18.00 (457)	43.50 (1105)	3.00 (76)	0.50 (13)	1.25 (32)	-	0.44 (11)	0.25 (6)	1	405
5PW	12, 4	NC	24.00 (610)	42.00 (1067)	12.25 (311)	18.00 (457)	43.50 (1105)	3.00 (76)	0.50 (13)	1.25 (32)	-	0.44 (11)	0.25 (6)	1	405
5PW	1, 12	CB DS	36.00 (914)	70.00 (1778)	16.00 (406)	33.75 (857)	12.50 (318)	1.25 (32)	1.25 (32)	2.50 (64)	3.25 (83)	0.69 (18)	-	2	445
6PW	1, 12	NC	28.00 (711)	56.00 (1422)	16.00 (406)	25.75 (654)	12.88 (327)	1.24 (31)	1.24 (31)	2.50 (64)	3.25 (83)	0.69 (18)	-	2	690
6PW	4	NC	28.00 (711)	64.00 (1626)	16.00 (406)	26.00 (660)	9.00 (229)	1.00 (25)	3.00 (76)	2.50 (64)	3.25 (83)	0.69 (18)	-	-	690
6PW	1, 12	CB DS	64.00 (1626)	90.00 (2286)	24.00 (610)	61.75 (1568)	17.25 (438)	1.13 (29)	4.38 (111)	3.38 (86)	3.25 (83)	0.81 (21)	-	3	730

\* Disconnect Options:

NC = Non-combination - standard

CB = Factory installed circuit breaker - form Y791

DS = Factory installed disconnect switch - fusible or non fusible - form Y792 through Y798



**Class 8600 Reduced Voltage Starters  
Part Winding Starters  
Dimensions and Weight**

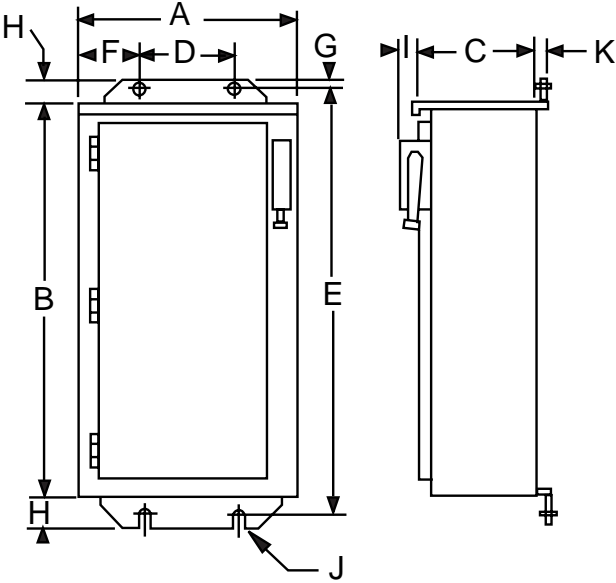

Enclosure Style 1

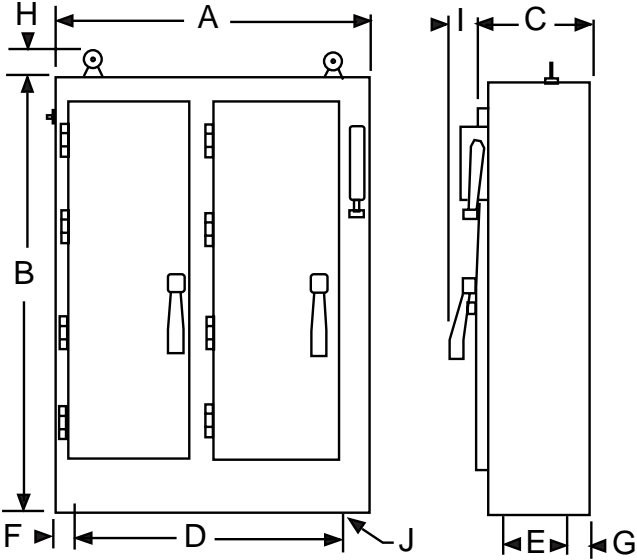

Enclosure Style 3

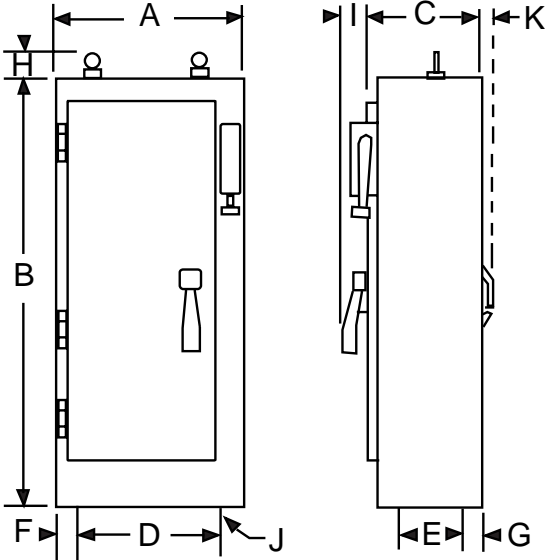

Enclosure Style 2



# Class 8600 Reduced Voltage Starters OEM Kits Starter Description and Selection

## Starter description

Electromechanical reduced voltage starters are available in pre-engineered kits. Class 8606, 8630 and 8640 O.E.M. kits are supplied with the following components:

- Basic starter:** Contactor(s)  
Starter(s)  
Overload relay block(s)  
Timing relay
- Class specific components:** Mechanical interlock  
Autotransformer  
Shorting bar  
Resistors & mounting hardware
- Documentation:** Elementary wiring diagrams  
Mounting templates  
Instruction bulletins  
Thermal overload selection sheet  
Short circuit protection guide

Starter kits do not include wiring or sheet metal.

## Selection

Electromechanical reduced voltage starters are available in the following sizes:

Horsepower Range	Class 8606 Autotransformer	Class 8630 Wye Delta	Class 8640 Part Winding
@ 208 Vac	10 to 150 HP	25 to 300 HP	15 to 150 HP
@ 230 Vac	10 to 200 HP	30 to 300 HP	15 to 150 HP
@ 460 Vac	10 to 400 HP	50 to 600 HP	20 to 300 HP
NEMA Size Range	2 to 6	3YD to 6 YD	2PW to 5PW

To specify an O.E.M. starter kit, select the Class and Type number of the starter from page 6 and change the 7th digit of the catalog number to "K".



Example: For a 100 HP / 460 Vac autotransformer starter kit, with the timing relay at 120 Vac, specify 8606SFK1MV81S.

The only allowable factory modifications are for control configuration or overload relay modifications. Either S or Y195 must be specified with a V8\* voltage code to indicate coil configuration.



## Class 8600 Reduced Voltage Starters Technical Specification Class 8606, 8630 & 8640 Starters

### Class 8606, 8630 & 8640 Starters

<b>Supply voltage</b>	200, 230 460 , 575V (+10% / - 15%)	220, 380, 415 or 500 (+10% / - 15%)
<b>Frequency</b>	@ 60 Hz	@ 50Hz
<b>Conformity to standards</b>	All starters meet the requirements of UL508   Listing: Guide NLDX File E70074	
<b>Ambient air temperature</b>	-20° C to 50° C operating -30° C to 70° C storage	
<b>Maximum operating altitude</b>	Above 3,000 feet, derating factor must be used to select thermal overload heater units. Refer to instruction bulletin for derating factors.	
<b>Terminals</b>	All terminals, both power and control, are sized for use with solid or stranded copper wire. If a disconnect means is provided, the source power terminal size is determined by the disconnect means provided.	

NEMA Size	Type	Power Terminals		Control Terminals	
		Lug Type	Wire Size (Min-Max)	Lug Type	Wire Size (Min-Max)
1 / 1YD / 1PW	SC	Box Lug	#14 - #8	Pressure Wire	#16 - #12
2 / 2YD / 2PW	SD	Box Lug	#14 - #4	Pressure Wire	#16 - #12
3 / 3YD / 3PW	SE	Box Lug	#14 - 1/0	Pressure Wire	#16 - #12
4 / 4YD / 4PW	SF	Box Lug	#8 - 250 kcmil	Pressure Wire	#16 - #12
5 / 5YD / 5PW	SG	Box Lug	#4 - 500 kcmil	Pressure Wire	#16 - #12
6 / 6YD / 6PW	SH	Parallel Groove	One or two 250 - 500 kcmil per phase	Pressure Wire	#16 - #12
7 / 7YD / 7PW	SJ	Parallel Groove	One to four 250 - 500 kcmil per phase	Pressure Wire	#16 - #12

Power terminals suitable for use with 75°C rated conductors

### Class 8606 Starters

	NEMA Size	2	3	4	5	6	7
Rated continuous current	Amps	45	90	135	270	540	810
Maximum horsepower	200V	10	25	40	75	150	n/a
	230V	15	30	50	50	200	300
	300V	25	50	75	75	300	n/a
	460V / 575V	25	50	100	100	400	600
Short circuit withstand rating*		5,000	5,000	10,000	10,000	18,000	n/a

Factory Settings	65% tap 7 second transition from start to run		
Duty Cycle (on 65% tap)	Cycle On Off Repeat Rest	Up to 200 HP 15 seconds 3 min 45 sec 14 times (15 cycles) 2 hours	Above 200 HP 30 Seconds 30 seconds 2 times (3 cycles) 1 hour
Overload Selection	3 thermal units required Use 100% of motor FLA to select heater elements.		



**Class 8600 Reduced Voltage Starters  
 Technical Specification  
 Class 8606, 8630 & 8640 Starters**

**Class 8630 Starters**

	NEMA Size	1YD	2YD	3YD	4YD	5YD	6YD	7YD
Rated continuous current	Amps	47	78	156	233	467	935	1400
Maximum horsepower	200V	10	20	40	60	150	300	500
	230V	10	25	50	75	150	350	500
	300V	15	40	75	150	250	500	n/a
	460V / 575V	15	40	75	150	300	700	1000
Short circuit withstand rating*		5,000	5,000	5,000	10,000	10,000	18,000	n/a

Duty Cycle	Typically limited by motor thermal capacity. For starting times in excess of two minutes, select next larger starter size to prevent excessive wear on contact tips.
Factory Settings	Open transition start time delay - 10 seconds Closed transition start time delay - 15 seconds
Overload Selection	3 thermal units required Use 58% of motor FLA to select heater elements.

**Class 8640 Starters**

	NEMA Size	1PW	2PW	3PW	4PW	5PW	6PW	7PW
Rated continuous current	Amps	54	90	180	270	540	1080	1620
Maximum horsepower	200V	10	20	40	75	150	n/a	n/a
	230V	10	25	50	75	150	300	450
	300V	15	40	75	125	250	500	n/a
	460V / 575V	15	40	75	150	300	600	900
Short circuit withstand rating		5,000	5,000	5,000	10,000	10,000	18,000	n/a

Duty Cycle	Limited by motor thermal capacity. Starting times greater than 3 seconds not recommended
Factory Settings	1.5 second transition from start to run
Overload Selection	6 thermal units required Use 50% of motor FLA to select heater elements.





---

**SQUARE D**

Square D Company  
P.O. Box 27446  
Raleigh, N.C. 27611, USA

UL is a registered trademark of Underwriters Laboratory  
MOTOR LOGIC™ is a trademark of Square D Company

8600CT9601 February 1997 Printed in USA  
Replaces Catalog 8600 dated 9/85



© 1985 Square D All Rights Reserved