

# Sensors

Proximity, Photoelectric, and Ultrasonic Sensors, Limit Switches, Pressure Sensors, Machine Safety, Encoders, RFID, and Machine Cabling



# 10—OsiSense® XG Radio Frequency Identification System 13.56 MHz

---

<b>Selection guide</b> .....	<b>10/2</b>
■ Introduction, Description .....	10/4
■ Specifications .....	10/10
■ Catalog Numbers .....	10/12
■ Dimensions .....	10/16
■ Connections .....	10/18
■ Operating Curves .....	10/20
■ Installation Information .....	10/21

<b>Applications</b>	Numerous and varying applications in the industrial, logistic and building sectors: flexible production workshops, traceability, access control, etc.	
<b>Compact stations, 13.56 MHz</b>	<b>Flat form 40</b>	<b>Flat form 80</b>







<b>Dimensions, W x H x D (mm)</b>	40 x 40 x 15	80 x 80 x 26
<b>Protocols</b>	Modbus® RTU and Uni-Telway™	
<b>Nominal sensing distance depending on associated tag, mm (in.)</b>	18 to 70 (0.71 to 2.76)	20 to 100 (0.79 to 3.94)
<b>Station type</b>	<b>XGCS4901201</b>	<b>XGCS8901201</b>
<b>Page</b>	10/16	

<b>Electronic tags</b>	<b>Flat form 40</b>	<b>ISO badge (1)</b>	<b>Disc</b>	<b>Flat form 26</b>	<b>Cylindrical</b>
------------------------	---------------------	----------------------	-------------	---------------------	--------------------

<b>Dimensions, W x H x D (mm)</b>	40 x 40 x 15					54 x 85.5 x 0.8	Ø 30 x 3	Ø 30 x 3	26 x 26 x 13	M18 x 1 x 12	
<b>Type of memory</b>	EEPROM		FeRAM			EEPROM		FeRAM	EEPROM		
<b>Memory capacity (bytes)</b>	3,408	13,632	2048	8192	32,768	256	112	2048	256	256	
<b>Nominal sensing distance, mm (in.) (3)</b>	<b>With station XGCS49●</b>	33 (1.30)	30 (1.18)	45 (1.77)	—	—	70 (2.76)	48 (1.89)	45 (1.77)	40 (1.57)	18 (0.71)
	<b>With station XGCS89●</b>	48 (1.89)	40 (1.57)	65 (2.56)	39 (1.54)	39 (1.54)	100 (3.94)	65 (2.56)	65 (2.56)	55 (2.17)	20 (0.79)
<b>Time (ms) (4)</b>	<b>Read (2)</b>	9.25 + 0.375 x n	16.25 + 0.375 x n	2 x n	6 + 0.25 x n	6 + 0.25 x n	12 + 0.825 x n		2 x n	12 + 0.825 x n	
		<b>Write (2)</b>	13 + 0.8 x n	20 + 0.8 x n	2.4 x n	6 + 0.25 x n	6 + 0.25 x n	20 + 11.8 x n	12 + 5.6 x n	2.4 x n	20 + 11.8 x n
<b>Tag type</b>	<b>XGH B444345</b>	<b>XGH B445345</b>	<b>XGH B440245</b>	<b>XGH B440845</b>	<b>XGH B443245</b>	<b>XGH B90E340</b>	<b>XGH B320345</b>	<b>XGH B320246</b>	<b>XGH B221346</b>	<b>XGH B211345</b>	
<b>Page</b>	16										

(1) Customized versions on request.  
 (2) n = number of 16-bit words.  
 (3) Metal mounted: See the sensing distances under "Minimum permissible mounting distances in a metal structure" on page 10/21.  
 (4) Does not include the network transfer time.

<b>Connection boxes</b>	<b>Ethernet box</b>	<b>Tap-off box</b>	<b>PROFIBUS® box</b>
			
<b>Protocols</b>	Modbus TCP/IP	Modbus and Uni-Telway	PROFIBUS-DP
<b>Associated compact stations</b>	XGCS49● and XGCS89●		
<b>Supply voltage</b>	24 Vdc		
<b>Connection box type</b>	<b>XGSZ33ETH</b>	<b>TCSAMT31FP</b>	<b>XGSZ33PDP</b>
<b>Page</b>	6		

<b>Field expanders</b>	<b>Conveying type</b>	<b>Universal type</b>
		
<b>Dimensions, W x H x D (mm)</b>	400 x 23 x 50	250 x 250 x 10
<b>Dialogue area, W x H (mm)</b>	380 x 45	230 x 230
<b>Associated compact stations</b>	XGCS4901201	
<b>Nominal sensing distance depending on associated tag (mm)</b>	30 to 90	26 to 150
<b>Field expander type</b>	<b>XGFEC540</b>	<b>XGFEC2525</b>
<b>Page</b>	7	

<b>Portable terminal</b>	<b>For 13.56 MHz RFID diagnostics</b>
	
<b>Function</b>	Read/Write operations on electronic tags and diagnostics on compact stations
<b>Operating system</b>	Microsoft Windows CE.NET Professional version 4.2
<b>Terminal type</b>	<b>XGSTP401</b>
<b>Page</b>	10/13

<b>OsiSense XG accessories</b>	Cables, adaptors, mounting plates, etc.
<b>Pages</b>	10/13 to 10/15

#### Operating principle

RFID is a term used for radio frequency identification systems. The frequencies range between 50 kHz and 2.5 GHz. The most widely used is 13.56 MHz.

The OsiSense XG radio frequency identification system allows object traceability, object tracking, and access control functions to be performed. Information is stored in an accessible memory bank using a simple radio frequency link. This memory bank is in the form of an electronic tag, which contains an antenna and an integrated circuit.

The tag contains the information associated with the object to which the tag is attached. When a tag passes through the field generated by the reader station, it detects the signal and exchanges the read or write data between its memory and the reader station.

The applications are numerous and include the following:

- Logistics: dispatch, receipt, transit
- Tracking and sorting of baggage
- Automatic tolls
- Access control

The OsiSense XG radio frequency identification system is also suited to difficult environments (humidity, temperature, mechanical shock, vibration, dust, etc.).

#### OsiSense XG Radio Frequency Identification System

The OsiSense XG radio frequency identification system is open to the majority of ISO 18000-3, ISO 15693 and ISO 14443 electronic tags.

The XG RFID system integrates Modbus RTU, Uni-Telway, Modbus TCP/IP, and PROFIBUS-DP protocols.

The OsiSense XG RFID system offer includes:

- Two models of 13.56 MHz compact stations (read/write)
- Six models of 13.56 MHz electronic tags
- One portable RFID diagnostics terminal
- Three models of network connection boxes
- Two models of field expanders (accessories that allow you to adapt the shape of the dialog zone between the tag and the compact station)
- Connection and mounting accessories

#### Setup

XG RFID compact stations are simple to set up, thanks to the following features:

- Integrated RFID and network functions
- No programming
- Automatic detection of the RFID electronic tags (read or write)
- Automatic setting of the communication parameters (speed, format, parity, protocol, etc.)
- Configuration of the network address (1 to 15) using the badge included with the station
- Read/write compatibility with the majority of 13.56 MHz tags on the market
- Low sensitivity to metal environments

#### Installation

The XG RFID stations are compact and robust. They can easily be integrated into flexible manufacturing production lines in the following ways:

- quick connection using the M12 connector
- clip-on mounting

An extensive range of connecting cables and adapter boxes allow the OsiSense XG stations to be easily connected to communication networks.

#### Description

##### XG RFID 13.56 MHz compact stations (1)

XGCS stations allow the reading and writing of 13.56 MHz RFID tags that comply to standards ISO 15693 and ISO 14443 A and B.

2 models of XG RFID compact stations are available:

- Format C compact station: XGCS490●●●●:
  - Dimensions (mm): 40 x 40 x 15
  - Nominal sensing distance: 18–70 mm (0.71–2.76 in.), depending on the associated tag
- Format D compact station: Station XGCS890●●●●:
  - Dimensions (mm): 80 x 80 x 26
  - Nominal sensing distance: 20–100 mm (0.79–3.94 in.), depending on the associated tag

(1) For station and tag selection according to passing speeds, see page 10/19.



Compact station, Flat form 40



Compact station, Flat form 80

# OsiSense® XG

## Radio Frequency Identification System

### 13.56 MHz

#### XG RFID 13.56 MHz compact stations (continued)

■ **Functions integrated into compact stations:** XG RFID compact stations integrate functions that simplify communication among the tags, the stations, and the controller (PLC, PC, etc.). These built-in functions are activated by standard reading/writing of word requests sent by the PLC:

- **Firmware version:** the station is interrogated to read its version
- **Reset:** the station is reinitialized and assumes its factory default configuration (network address at 1, transmission speed at 19,200 Bd, parameters deleted)
- **Init:** the station is reinitialized and operates as if reconnected to the supply (address unchanged, transmission speed unchanged, parameters deleted)
- **Sleep mode:** the transmission of the electromagnetic field of the station is only activated on its receipt of a read or write instruction. This mode reduces the power consumption of the station and enables the suppression of interference when the stations are close to each other
- **Auto Read/Write:** This mode enables the station to automatically execute up to 10 read or write instructions (up to 128 write words and up to 126 read words) in a tag as soon as it enters the dialog zone

#### XG RFID electronic tags (1)

XGHB electronic tags offer the following advantages:

- fast access to the data
- wide range of memory capacities
- security of access to the contents
- operation without battery
- positioning flexibility
- protection suited to the environmental conditions

The nominal transmission distance is 18–100 mm (0.70–3.93 in.) depending on the model of the tag and the associated compact station.

#### Portable 13.56 MHz RFID diagnostics terminal

The portable terminal **XGSTP401** is designed for use in industrial applications. Its rugged structure combined with its numerous functions make it suitable for applications in difficult environments. It operates on Microsoft® Windows® CE.NET Professional version 4.2 operating system. The 13.56 MHz RFID function and OsiSense XG RFID system software installed on the portable terminal allow maintenance operations to be performed on the electronic tags and compact stations.

Transfer of data to a PC is made via an RS-232 communication port.

The portable terminal **XGSTP401** comprises a:

- 1 CF (Compact Flash) format expansion connector
- 2 Color touchscreen
- 3 Keypad (45 keys)
- 4 RS-232 port

The following accessories are included with the terminal:

- PC connecting cable
- OsiSense XG RFID system software (installed)
- battery, universal battery charger, 3 styluses, protective cover
- user guide

#### Field expander

Field expanders are accessories designed to operate with the XG RFID stations. They allow you to adapt the shape of the dialog field of XGCS4901201 stations to conveying/handling applications. The concept is a connection-free induction link between the station and the field expander. Two standard models are available:

- The conveyor model **XGFEC540** detects ISO 15693 tags on a narrow strip covering the width of the conveyor (mounted between two rollers of the conveyor)
  - Dimensions (mm): 400 x 23 x 50
  - Nominal sensing distance: 30–90 mm (1.18–3.54 in.) depending on the associated tag
- The universal model **XGFEC2525** increases the detection area and distance of ISO 15693 tags, which also permits higher passing speeds of the tags
  - Dimensions: 250 x 250 x 10
  - Nominal sensing distance: 26–150 mm (1.02–5.90 in.) depending on the associated tag
- Read/write compatibility with the majority of the 13.56 MHz/ISO 15693 tags on the market

(NOTE: These accessories are not compatible with ISO 14443 tags)

(1) For station and tag selection according to passing speeds, see page 10/19.



Electronic tags

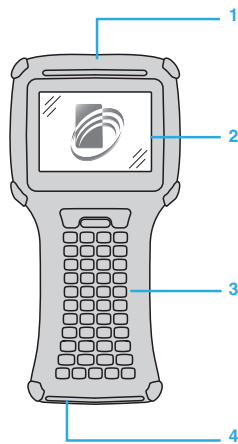

Portable diagnostics terminal



Field expanders

# OsiSense® XG

## Radio Frequency Identification System

### 13.56 MHz

#### XG RFID connection boxes

Three types of quick connection boxes are available:

- Ethernet box **XGSZ33ETH** for an Ethernet Modbus TCP/IP network
- Tap-off box **TCSAMT31FP** for a Modbus or Uni-Telway communication bus
- PROFIBUS box **XGSZ33PDP** for a PROFIBUS-DP network

#### Ethernet box XGSZ33ETH

The XG RFID Ethernet box **XGSZ33ETH** allows you to connect XGCS stations to an Ethernet network (Modbus TCP/IP protocol).

It provides PLC or PC access to the following functions of XGCS stations:

- reading/writing of tags
- control and checking
- monitoring
- diagnostics

The **XGSZ33ETH** Ethernet box is fitted with M12 connectors. It is used to connect the power supply, the Ethernet network, and 1–3 XGCS stations.

It comprises a sealed metal enclosure fitted with the following:

- 1 Power On and Ethernet signaling LEDs
- 2 One Ethernet socket, M12 type, D coding
- 3 One power supply socket, M12 type, 4-pin male
- 4 3 sockets, M12 type female, A coding, for connecting 1–3 XGCS stations.

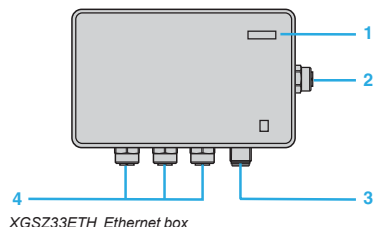

XGSZ33ETH Ethernet box

#### Tap-off box TCSAMT31FP

The XG RFID tap-off box **TCSAMT31FP** allows you to connect XGCS stations to a Modbus or Uni-Telway communication bus.

The **TCSAMT31FP** tap-off box is fitted with M12 connectors. It is used to connect the supply, the Modbus communication bus, and 1–3 XGCS stations.

It comprises a sealed metal enclosure fitted with the following:

- 1 One green LED indicator: Power On
- 2 One network output socket, M12 type 5-pin female, A coding
- 3 One network input socket, M12 type 5-pin male, A coding
- 4 One power supply socket, M12 type 4-pin male, A coding
- 5 3 sockets, M12 type female, A coding, for connecting 1–3 compact XGCS stations

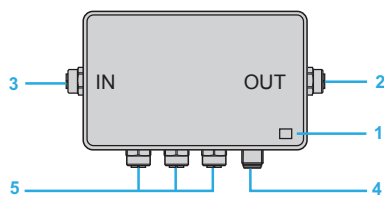

TCSAMT31FP tap-off box

#### PROFIBUS box XGSZ33PDP

The XG RFID PROFIBUS box **XGSZ33PDP** allows you to connect XGCS stations to a PROFIBUS-DP network.

It provides PLC or PC access to the functions of XGCS stations:

- reading/writing of tags
- control and checking
- monitoring
- diagnostics

The **XGSZ33PDP** PROFIBUS box is fitted with M12 connectors. It is used to connect the power supply, the PROFIBUS-DP network, and 1–3 XGCS stations.

It comprises a sealed metal enclosure fitted with the following:

- 1 Two coding wheels for configuration of the network address
- 2 One PROFIBUS network input socket, M12 type 5-pin male, B coding
- 3 3 sockets, M12 type female, A coding, for connecting 1–3 XGCS stations
- 4 One power supply socket, M12 type 4-pin male, A coding
- 5 One configuration port (M12 type female, A coding)
- 6 PROFIBUS network, Modbus network, and connection box status signaling LEDs
- 7 One PROFIBUS network output socket, M12 type 5-pin female, B coding.

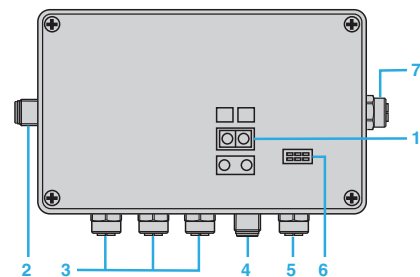

XGSZ33PDP Ethernet box

## Mounting example for Modbus® network

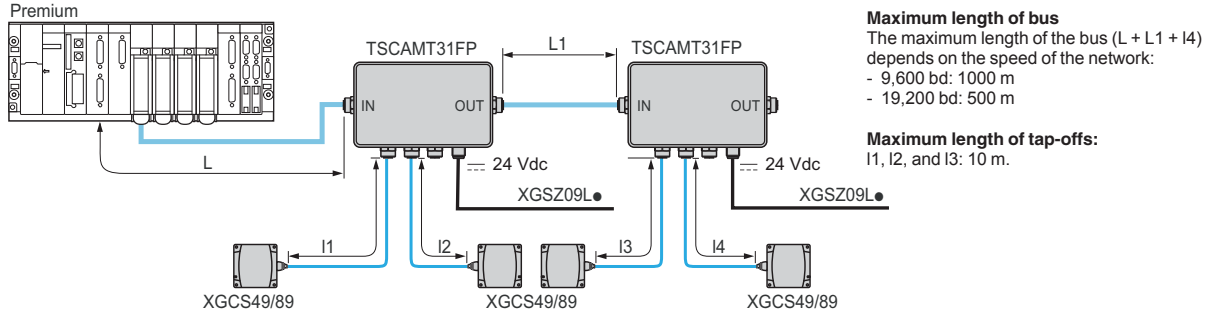

## Example of connection to a Schneider Electric PLC

### Direct connection

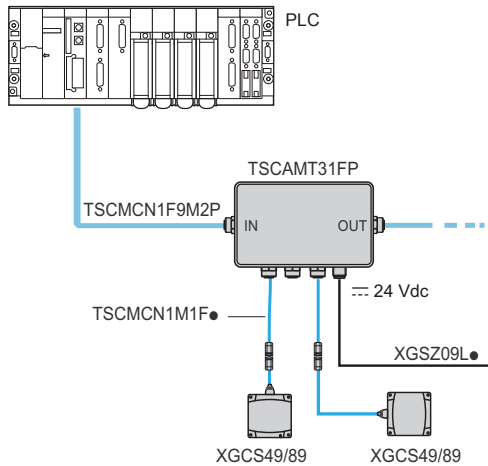

### Connection via a TSXCSA62

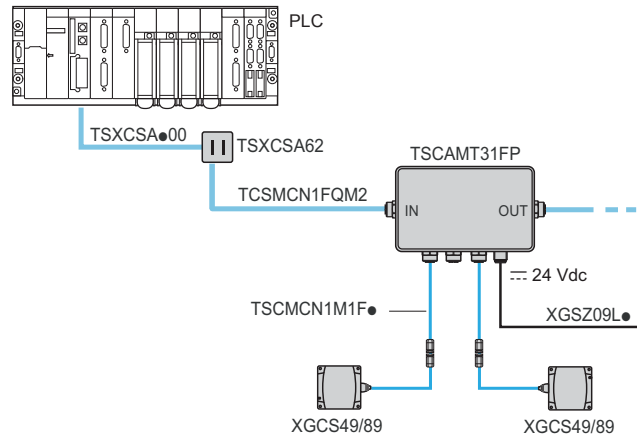

### Example of a connection on an Ethernet Modbus® TCP/IP network

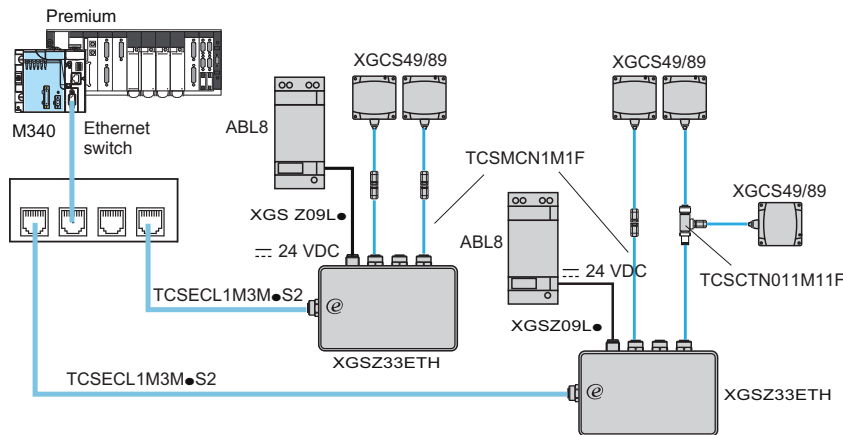

The number of stations connected to each box can be increased by using the M12 T-connector (catalog number TCSECTN011M11F). To maintain high-performance operation, we recommend that a maximum of 8 compact stations be connected (the Ethernet box has eight communication ports that can be simultaneously open on TCP/IP). In cases where the I/O scanning function is used (which requires an additional communication port), do not connect more than seven stations. The total length of the station side network for XGCS stations (XGCS49 and XGCS89) is limited to 160 m.

### Example of a mixed IP 20 and IP 67 connection on an Ethernet Modbus® TCP/IP network

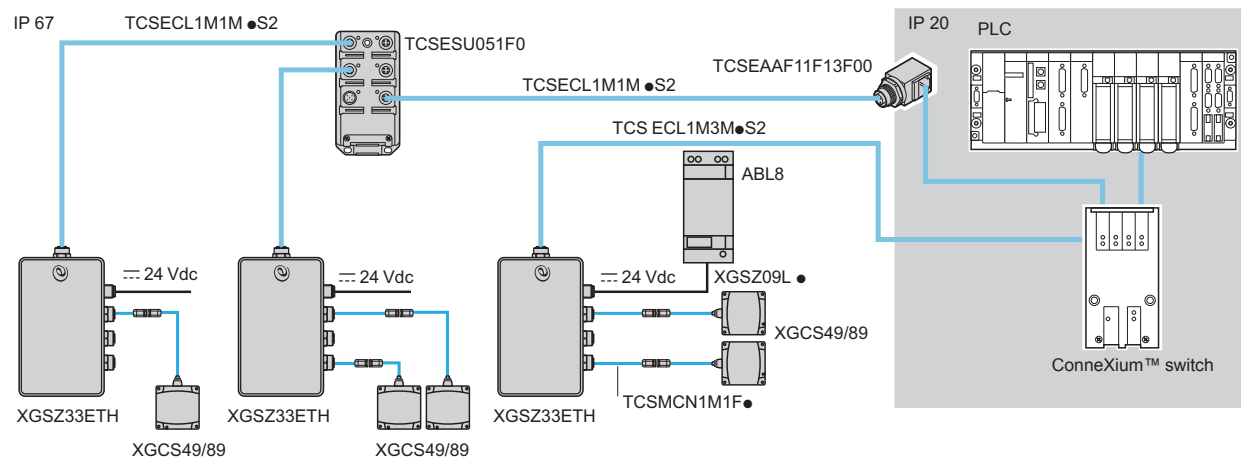

### Example of a connection to a Magelis® terminal

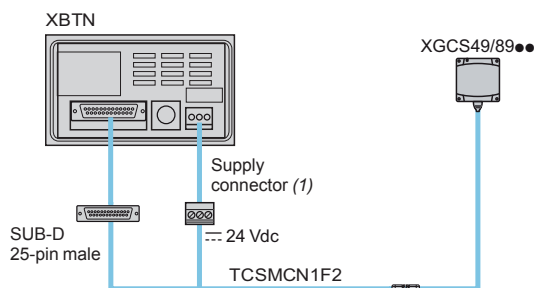

Cable TCSCMN1F2 connections

Scheme	Contact	Signal	Wire color
	1	Drain (Modbus-SHLD)	—
	2	24 Vdc	Red
	3	0 V Modbus-GND	Black
	4	D0	White
	5	D1	Blue

1) Magelis® terminal supply connector (included with the Magelis terminal).

### Example of an architecture in a PROFIBUS network

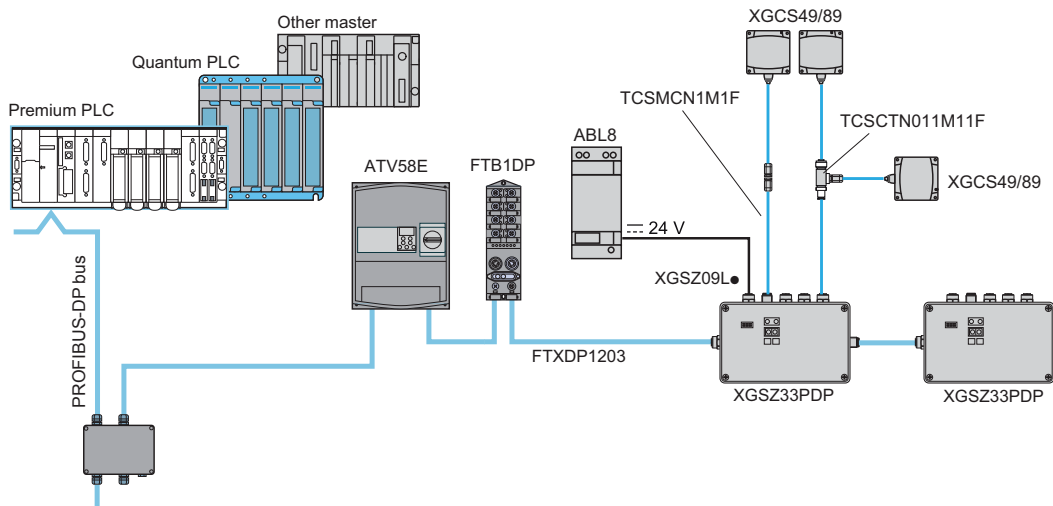

### Example of a connection on a Twido® PLC

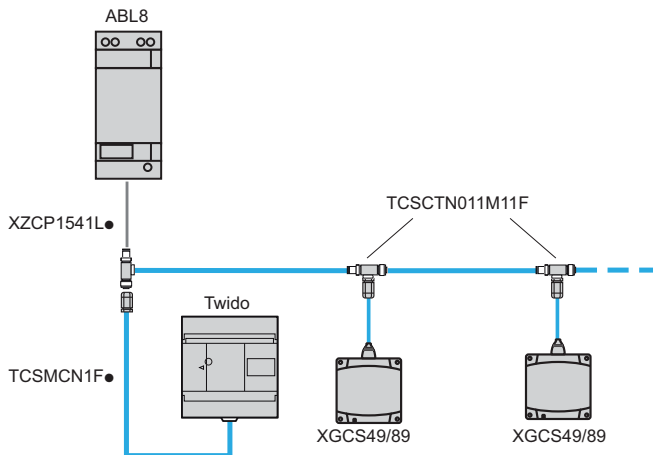

### Example of a connection to a PC

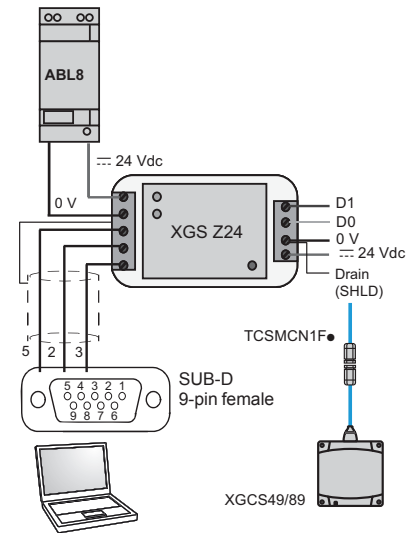

### Power supply cable connections

XZCP1541L				Power supply ABL8	
Scheme	Contact	Signal	Wire color	Terminal	
	1	NC	Brown	-	
	2	24 Vdc	White	24 Vdc	
	3	0 V GND	Blue	0 V GND	
	4	NC	Black	-	

### TCSCMN1F cable connections

TCSCMN1F				Twido® PLC	
Scheme	Contact	Signal	Wire color	Terminal	Scheme
	1	Drain (SHLD)	-	-	
	2	24 Vdc	Red	-	
	3	0 V GND	Black	SG	
	4	D0	White	B	
	5	D1	Blue	A	

The compact stations can be directly connected to the Modbus port of a PLC. Up to 15 compact stations can be linked to the RS-485 port using T-connectors. (In cases where the length of the network exceeds 100 m, fit a line terminator, catalog number FTXCNTL12.) This cabling system is specific to the OsiSense® XG RFID System (powered network). No other Modbus slave equipment can be connected to it.

Specifications of XG RFID compact stations			
Station type		XGC S4901201	XGC S8901201
<b>Certifications</b>		UL, FCC part 15c	
<b>Conformity to standards</b>		CE, EN 301489-1, EN 301489-3, ETS 300330-1 and ETS 300330-2	
<b>Ambient air temperature</b>	For operation	°C (°F)	-25 to +70 (-13 to +158)
	For storage	°C (°F)	-40 to +85 (-40 to +185)
<b>Degree of protection</b>		Conforming to IEC 60529	
<b>Vibration resistance</b>		Conforming to EN 60068.2.27	
<b>Shock resistance</b>		Conforming to EN 60068.2.6	
<b>Resistance to interference</b>		Conforming to EN 50102	
<b>Dimensions, W x H x D</b>		mm	Flat form 40: 40 x 40 x 15
<b>RFID frequency</b>		MHz	13.56
<b>Type of associated tag</b>		ISO 15693 and ISO 14443 standard tags. Automatic detection of the type of tag	
<b>Compatible RFID microchip examples</b>		Texas (Tag-it HFI); Philips (SL2, SL1, Ultralight, Std 1K/2K, Desfire; STM (CR1X4K); INSIDE (micropass)	
<b>Nominal sensing distance</b>	Depending on associated tag	mm (in.)	18–70 (0.71–2.76)
<b>Nominal supply voltage</b>		Vdc	--- 24 PELV (Protective Extra Low Voltage)
<b>Supply voltage limits (including ripple)</b>		Vdc	--- 19.2–29
<b>Consumption</b>		mA	< 60
<b>Serial links</b>	Type	RS-485	
	Protocol	Modbus RTU or Uni-Telway	
	Speed	Bd	9,600–115,200 (automatic detection)
<b>Display</b>		1 dual color LED for the communication network: Modbus/Uni-Telway 1 dual color LED for the RFID communication (Presence of tag / Station/tag dialog)	
<b>Connections</b>		M12, 5-pin male, shielded connector. Only for connection to the communication network and the supply.	
<b>Tightening torque</b>	Screws	Nm	< 1

Specifications of XG RFID electronic tags							
Tag type		XGHB444345	XGHB445345	XGHB90E340	XGHB320345	XGHB221346	XGHB211345
<b>Ambient air temperature</b>	For operation	°C (°F)	-25 to +70 (-13 to +158)	-25 to +50 (13 to +122)	-25 to +70 (-13 to +158)		
	For storage	°C (°F)	-40 to +85 (-40 to +185)	-40 to +55 (-40 to +131)	-40 to +85 (-40 to +185)		
<b>Degree of protection</b>		IP 68		IP 65		IP 68	
<b>Standard supported</b>		ISO 14443		ISO 15693			
<b>Vibration resistance</b>		Conforming to EN 60068.2.27		2 mm from 5 to 29.5 Hz / 7 gn from 29.5 to 150 Hz			
<b>Shock resistance</b>		Conforming to EN 60068.2.6		30 g/11 ms			
<b>Dimensions</b>		mm	40 x 40 x 15	40 x 40 x 15	54 x 85.5 x 1	Ø 30 x 3	26 x 26 x 13
<b>Housing material</b>		PBT		PBT	PVC	PVC	PBT
<b>Mounting method</b>		Screw or clip		Screw or clip	-	Screw	Screw or clip
<b>Memory capacity</b>		bytes	3,408	13,632	256	112	256
<b>Type of memory</b>		EEPROM					
<b>Type of operation</b>		Read/Write					
<b>Type of associated station</b>		XGC S●●●●●●					
<b>Nominal sensing distance (Read/Write)</b>	With station XGC S49	mm (in.)	33 (1.30)	30 (1.18)	70 (2.76)	48 (1.89)	40 (1.57)
	With station XGC S89	mm (in.)	48 (1.89)	40 (1.57)	100 (3.94)	65 (2.56)	55 (2.17)
	With station XGC S49011201 + field expander XGFEC540	mm (in.)	-	-	90 (3.54)	42 (1.65)	-
	With station XGC S49011201 + field expander XGF EC2525	mm (in.)	-	-	150 (5.91)	80 (3.15)	42 (1.65)
<b>Number of read cycles</b>		Unlimited					
<b>Number of write cycles</b>	Minimum	100,000 per data bit throughout the temperature range					
	At 30 °C (86 °F)	2.5 million (typical value)					
<b>Read time</b>		ms	9.25 + 0.375 x n (1)	16.25 + 0.375 x n (1)	12 + 0.825 x n (1)		
<b>Write time</b>		ms	13 + 0.8 x n (1)	20 + 0.8 x n (1)	20 + 11.8 x n (1)	12 + 5.6 x n (1)	20 + 11.8 x n (1)
<b>Data retention time</b>		10 years					
<b>Mounting on metal support</b>		Yes (2)		No		Yes (2)	

(1) n = number of 16-bit words.  
(2) Installation notes: see page 21.

Specifications of XG RFID connection boxes					
Connection box type			Tap-off box TCSAMT31FP	Ethernet box XGSZ33ETH	PROFIBUS box XGSZ33PDP
<b>Certifications</b>			UL		
<b>Conformity to standards</b>			CE		
<b>Ambient air temperature</b>	For operation	°C (°F)	-25 to +55 (-13 to +131)	0 to +70 (32 to +158)	0 to +55 (32 to +131)
	For storage	°C (°F)	-40 to +85 (-40 to +185)	-40 to +85 (-40 to +185)	-25 to +85 (-40 to +185)
<b>Relative humidity</b>		<b>RH</b>	30 to 95% without condensation		
<b>Degree of protection</b>			IP 65		
<b>Supply voltage</b>		<b>Vdc</b>	--- 24 PELV (limits 19.2–29 V), M12, 4-pin male, A coding, connector		--- 24 PELV (limits 21.6–26.4 V), M12, 4-pin male, A coding, connector
<b>Consumption</b> (connection box only)		<b>W</b>	–	< 1	< 2.5
<b>Station connection</b>			M12 5-pin female, A coding, connector		
<b>Electromagnetic interference</b>	Conforming to IEC 61000		Level 3		
	Conforming to EN 55022		Class B		
<b>LED display</b>			Power on (green)	- Ethernet network activity (RUN, green) - Collision detection (COL, red) - Diagnostics (STS, yellow) - Error (Err, red) - Power on (green)	- PROFIBUS network activity (RUN, green) - PROFIBUS network activity (OFF, red) - Communication bus (Error, flashing red) - Modbus (RUN, green) - Gateway configuration (green)
<b>Transparent Ready® Services</b>	Class		–	A10	–
	Basic Web server		–	IP configuration address	–
	Basic communication service		–	Modbus messaging (reading/writing of words: 1 to 123 words per request)	Reading/writing of words (1 to 49 per request) via the PROFIBUS-DP periodic exchanges service. PROFIBUS-DP V2 aperiodic exchanges not supported
<b>Connection</b>	Physical interface		–	10 BASE-T/100BASE-TX	–
	Transfer rate		–	10/100 Mbps	9.6–12,000 Kbd: automatic detection of speed
	Medium		–	Ethernet cable with M12 connection, catalog number TCS ECL1M1●S2 (Schneider Electric ConneXium™ range)	RS-485 twisted pair

Specifications of portable 13.56 MHz RFID diagnostics terminal					
<b>Conformity to standards</b>			CE, FCC class A, Part 15225		
<b>Ambient air temperature</b>	For operation	°C (°F)	0 to +50 (32 to +122)		
	For storage	°C (°F)	-25 to +55 (-13 to +131)		
<b>Relative humidity</b>		<b>RH</b>	5–95% without condensation		
<b>Degree of protection</b>			IP 65		
<b>Supply voltage</b>			7.2 V NiMH type rechargeable battery (included with terminal) External: --- 11–18 Vdc		
<b>Operating time</b>			4 hours continuous operation (tag dialog)		
<b>Operating system</b>			Microsoft Windows CE.NET Professional version 4.2		
<b>Processor</b>			Intel Xscale® PXA255 CPU, 400 MHz		
<b>Memory</b>	RAM		SDRAM 64 Mb (16 Mb reserved for operating system)		
	Storage		Internal compact Flash: 512 Mb standard + Slot for compact Flash card (such as memory, wi-fi, Ethernet, or Bluetooth)		
<b>Display</b>	Screen		Color touchscreen: 72 mm x 54 mm, QVGA TFT		
	Resolution		320 x 240 pixels		
<b>Keypad</b>			45 booted keys		
<b>Signaling</b>			5 LEDs + 1 charging LED		

# OsiSense® XG

## Radio Frequency Identification System

### 13.56 MHz



XGCS4901201



XGHB44●345



XGHB90E340



XGHB221346



XGHB211345



XGHB320345



TCSAMT31FP

#### Compact stations, 13.56 MHz

Description	Protocols	Dimensions mm	Catalog number	Weight kg (lb)
<b>Compact station Flat form 40 (1)</b> M12 male connector on flying lead	Modbus RTU and Uni-Telway	40 x 40 x 15	<b>XGCS4901201</b>	0.057 (0.126)
<b>Compact station Flat form 80 (1)</b> M12 male connector on flying lead	Modbus RTU and Uni-Telway	80 x 80 x 26	<b>XGCS8901201</b>	0.257 (0.567)

#### Electronic tags

Tag type	Nominal sensing dist.		Dimensions mm	Sold in lots of	Unit catalog number	Weight kg (lb)
	XGCS49●	XGCS89●				
<b>Flat form 40</b> 3,408 bytes EEPROM	33 mm (1.30 in.)	48 mm (1.89 in.)	40 x 40 x 15	—	<b>XGHB444345</b>	0.031 (0.068)
<b>Flat form 40</b> 13,632 bytes EEPROM	30 mm (1.80 in.)	40 mm (1.57 in.)	40 x 40 x 15	—	<b>XGHB445345</b>	0.031 (0.068)
<b>Flat form 40</b> 2 KB FeRAM	45 mm (1.77 in.) (2)	65 mm (2.56 in.) (2)	40 x 40 x 15	—	<b>XGHB440245</b>	0.031 (0.068)
<b>Flat form 40</b> 8 KB FeRAM	—	39 mm (1.54 in.)	40 x 40 x 15	—	<b>XGHB440845</b>	0.031 (0.068)
<b>Flat form 40</b> 32 KB FeRAM	—	39 mm (1.54 in.)	40 x 40 x 15	—	<b>XGHB443245</b>	0.031 (0.068)
<b>ISO badge (3)</b> 256 bytes EEPROM	70 mm (2.76 in.)	100 mm (3.94 in.)	54 x 85.5 x 1	<b>10</b>	<b>XGHB90E340</b>	0.005 (0.011)
<b>Disc</b> 112 bytes EEPROM	48 mm (1.89 in.)	65 mm (2.56 in.)	∅ 30 x 3	<b>5</b>	<b>XGHB320345</b>	0.005 (0.011)
<b>Disc</b> 2 KB FeRAM	45 mm (1.77 in.)	65 mm (2.56 in.)	∅ 30 x 3	<b>5</b>	<b>XGHB320246</b>	0.005 (0.011)
<b>Flat form 26</b> 256 bytes EEPROM	40 mm (1.57 in.)	55 mm (2.17 in.)	26 x 26 x 13	<b>1</b>	<b>XGHB221346</b>	0.025 (0.055)
<b>Cylindrical</b> 256 bytes EEPROM	18 mm (0.71 in.)	20 mm (0.79 in.)	M18 x 1 x 12	<b>5</b>	<b>XGHB211345</b>	0.020 (0.044)

#### Connection boxes

Description	For use with	Supply voltage	Catalog number	Weight kg (lb)
<b>Ethernet box 3-channel</b> Integrated Ethernet port (10/100 Mbps) Modbus TCP/IP protocol Class A10	Compact stations XGCS49● and XGCS89●	∓ 24 Vdc	<b>XGSZ33ETH</b>	1.060 (2.337)
<b>Tap-off box 3-channel</b> Modbus and Uni-Telway	Compact stations XGCS49● and XGCS89●	∓ 24 Vdc	<b>TCSAMT31FP</b>	1.060 (2.337)
<b>PROFIBUS box 3-channel</b> PROFIBUS-DP protocol (4)	Compact stations XGCS49● and XGCS89●	∓ 24 Vdc	<b>XGSZ33PDP</b>	1.060 (2.337)

(1) Configuration badge XGSZCNF01 included with station—installation guide must be ordered separately (catalog number DIA4ED3051001).

(2) Metal mounted: 30 mm (1.18 in.) with XGCS49●; 45 mm (1.77 in.) with XGCS89●.

(3) Customized versions on request.

(4) Download GSD configuration file (SE100BBB.gsd) from [www.Schneider-Electric.com](http://www.Schneider-Electric.com) (Products and services/Automation and control/Detection/RFID).

# OsiSense® XG

## Radio Frequency Identification System

### 13.56 MHz



XGFEC540



XGFEC2525

#### Field expanders

Description	Nominal sensing distance	For use with	Catalog number	Weight kg (lb)
<b>Conveying type field expander</b> Dimensions (mm) 400 x 23 x 50 (1)	30–90 mm (1.18–3.54 in.) depending on tag used (only ISO 15693)	Station XGCS4901201 Tags XGHB90E340 XGHB320345 XGHB221346	<b>XGFEC540</b>	0.640 (1.411)
<b>Universal type field expander</b> Dimensions (mm) 250 x 250 x 10 (1)	26–150 mm (1.02–5.91 in.) depending on tag used (only ISO 15693)	Station XGCS4901201 Tags XGHB90E340 XGHB320345	<b>XGFEC2525</b>	0.565 (1.466)



XGSTP401



XGSTP41BA

#### Terminal and accessories

Description	Application	Catalog number	Weight kg (lb)
<b>Portable 13.56 MHz RFID diagnostics terminal (2)</b>	Read/write operations on electronic tags and diagnostics on compact stations Operating system: Microsoft Windows CE.NET Professional version 4.2	<b>XGSTP401</b>	0.943 (2.079)
<b>Battery pack charger</b>	Portable terminal	<b>XGSTP41CH</b>	0.675 (1.488)
<b>Battery, 7.2 V NiMH</b>	Portable terminal	<b>XGSTP41BA</b>	0.168 (0.370)
<b>Compact Flash memory expansion</b>	Portable terminal Capacity = 128 Mb	<b>XBTZGM128</b>	0.050 (0.110)



XGSZCNF01

#### Configuration badge (replacement)

Description	Application	Catalog number	Weight kg (lb)
<b>Badge</b>	Configuration of station addresses	<b>XGSZCNF01</b>	0.005 (0.011)

#### Documentation

Description	Catalog number	Weight kg (lb)
<b>XG RFID compact stations guide</b>	<b>DIA4ED3051001</b>	0.130 (0.029)

(1) For other dimensions, please consult your local sales office.

(2) Includes OsiSense® XG RFID system software (installed), universal battery charger, PC connecting cable, 3 styluses, protective cover, battery, and user guide.



TCSMCN1FQM2



TCSMCN1F9M2P

#### Modbus® network connection accessories

Description	Application	Length m	Catalog number	Weight kg (lb)
<b>Modbus shielded connecting cable, black, IP 67 M12 connectors, male/female, A coding (1)</b>	RS-485 connection between a compact station and a tap-off box	1	TCSMCN1M1F1	0.080 (0.176)
	TCSAMT31FP or between 2 tap-off boxes	2	TCSMCN1M1F2	0.115 (0.254)
		5	TCSMCN1M1F5	0.270 (0.595)
		10	TCSMCN1M1F10	0.520 (1.146)
<b>Modbus shielded pre-wired M12 connector, IP 67, female/bare wires, A coding (1)</b>	Connection between tap-off box TCSAMT31FP and Modbus/Uni-Telway network (TSXSCA50)	2	TCSMCN1F2	0.115 (0.254)
	5	TCSMCN1F5	0.270 (0.595)	
		10	TCSMCN1F10	0.520 (1.146)
<b>Modbus shielded connecting cable, black, M12/SUB-D15, A coding</b>	Connection between tap-off box TCSAMT31FP and Modbus/Uni-Telway network (TSXSCA62)	2	TCSMCN1FQM2	0.270 (0.595)
<b>Modbus shielded connecting cable, black, M12/Mini-DIN 8-way, A coding</b>	Modbus connection between tap-off box TCSAMT31FP and a PLC (such as Twido®)	2	TCSMCN1F9M2P	0.350 (0.772)
		500	TSXCSA500	30.000 (66.139)
<b>Modbus SL serial link cable (Shielded dual twisted pair RS-485 main cables)</b>	Modbus SL serial link	100	TSXCSA100	5.680 (12.522)
		200	TSXCSA200	10.920 (24.074)
		500	TSXCSA500	30.000 (66.139)

#### Ethernet connection accessories

##### Ethernet connection accessories for IP 67 switch

Description	End fittings	Length m	Catalog number	Weight kg
<b>Copper connecting cables, straight</b>	1 x IP 67 M12 4-pin connector and 1 x RJ45 connector	1	TCSECL1M3M1S2	–
		3	TCSECL1M3M3S2	–
		10	TCSECL1M3M10S2	–
		25	TCSECL1M3M25S2	–
		40	TCSECL1M3M40S2	–
	2 x IP 67 M12 4-pin connectors	1	TCSECL1M1M1S2	–
		3	TCSECL1M1M3S2	–
		10	TCSECL1M1M10S2	–
		25	TCSECL1M1M25S2	–
		40	TCSECL1M1M40S2	–
<b>M12 Ethernet switch IP 67, ConneXium™ (2)</b>	–	–	TCSESU051F0	0.210 (0.463)
<b>M12 female/RJ45 adapter</b>	Ethernet connection	–	TCSEAAF11F13F00	–

#### Do-It-Yourself Ethernet copper cable and connectors

The Do-It-Yourself ConneXium™ Ethernet system allows Ethernet copper connecting cables to be prepared on-site in the required length. The cables are intended for connection to the Ethernet 10/100 Mbps network. The maximum length of the connecting cables made in this way is 80 m. The cabling can be quickly assembled using a knife and ordinary wire cutters—no special tools required.

Description	Specifications	Length m	Catalog number	Weight kg (lb)
<b>Ethernet copper cable</b>	Conforms to applicable standards and approvals	300	TCSECN300R2	–
<b>2 x 24 AWG shielded dual twisted pairs</b>				
<b>RJ45 connector</b>	Conforms to EIA/TIA-568-D	–	TCSEK3MDS	–
<b>M12 connector</b>	Conforms to IEC 60176-2-101	–	TCSEK1MDRS	–

#### Power supplies

Description	Output voltage	Nominal power	Nominal current	Catalog number	Weight kg (lb)
	--- Vdc	W	A		
<b>Regulated power supply 100/240 Vac</b>	24	7	0.3	ABL8MEM24003	0.180 (0.397)
		30	1.2	ABL8MEM24012	0.520 (1.146)

(1) Holder for identification legend included with product.

(2) Other ConneXium™ connection accessories: refer to [www.Schneider-Electric.com](http://www.Schneider-Electric.com).



TCSESU051F0



TCSEAAF11F13F00



ABL8MEM24003

# OsiSense® XG

## Radio Frequency Identification System

### 13.56 MHz

#### PROFIBUS-DP connection accessories

Description	Composition	Type	Length m	Catalog number	Weight kg (lb)
Connecting cable for connection between PROFIBUS box XGS Z33DP and PROFIBUS-DP network	Fitted with 2 x M12 5-pin connectors	Straight	0.3	FTXDP1203	0.040 (0.088)
			0.6	FTXDP1206	0.070 (0.154)
			1	FTXDP1210	0.100 (0.220)
			2	FTXDP1220	0.160 (0.353)
			3	FTXDP1230	0.220 (0.485)
		Elbowed	5	FTXDP1250	0.430 (0.948)
			0.3	FTXDP3203	0.040 (0.088)
			0.6	FTXDP3206	0.070 (0.154)
			1	FTXDP3210	0.100 (0.220)
			2	FTXDP3220	0.160 (0.353)
			3	FTXDP3230	0.220 (0.485)
			5	FTXDP3250	0.430 (0.948)
			M12 connector, 5-pin male, B coding	–	FTXDP12M5
M12 connector, 5-pin female, B coding	–	FTXDP12F5	0.050 (0.110)		
Network terminator, M12 connector	–	FTXDPTL12	0.010 (0.022)		
Cable without end fittings	100	TSXPBSCA100	–		
	400	TSXPBSCA400	–		

#### Other connection accessories

Description	Application	Length m	Catalog number	Weight kg (lb)
Pre-wired M12 4-pin female supply connector, A coding (1)	24 V supply to connection boxes XGS Z33ETH and TCS AMT31FP	2	XGSZ09L2	0.115 (0.254)
		5	XGSZ09L5	0.270 (0.595)
		10	XGSZ09L10	0.520 (1.146)
M12 5-pin female, A coding, connector	–	–	FTXCN12F5	0.050 (0.110)
M12, 5-pin male, A coding, connector	–	–	FTXCN12M5	0.050 (0.110)
Network T connector, M12, 1 RS-485 network male/2 female 5-pin, A coding	–	–	TCS CTN011M11F	0.035 (0.070)
Supply connector, screw terminals, M12 straight, A coding	–	–	XZC C12FDM40B	0.020 (0.044)
Protective cap (Sold in lots of 10)	M12 female connector	–	FTXCM12B	0.100 (0.220)
Network terminator, M12 male, 120 Ω	–	–	FTXCNTL12	0.010 (0.022)
Line adapter, RS-232C/RS-485, without modem signals. Supply: 18–30 Vdc. Consumption: 20 mA. Maximum transmission speed: 19,200 bd. Mounting on 35 mm rail.	–	–	XGSZ24	–



TCS CTN011M11F



XGSZ3P

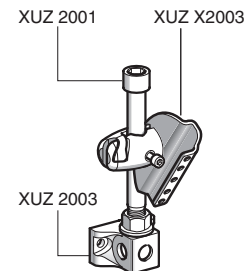

XUZ 2003

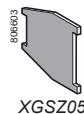

XGSZ05

#### Mounting accessories

Description	For use with	Catalog number	Weight kg (lb)
Clip-on 90° mounting bracket	Flat form 40 station: XGCS4901201	XSZBC90	0.060 (0.132)
	Flat form 40 tags: XGHB44●345		
Clip-on mounting plate	Tags XGHB221346	XSZBE90	0.060 (0.132)
	Flat form 40 station: XGCS4901201		
Mounting plate	Flat form 40 tags: XGHB44●345	XSZBC00	0.025 (0.055)
	Tags XGHB221346		
3D Mounting kit (2)	Field expander XGFEC2525	XSZBE00	0.025 (0.055)
Support for M12 rod		XUZ2003	0.220 (0.485)
M12 rod		XUZ2001	0.050 (0.110)
Ball-joint mounted mounting bracket		XUZ2003	0.220 (0.485)

(2) For a 3D mounting kit, order the following: rod support XUZ2003, M12 rod XUZ2001, and ball-joint mounting bracket XUZ2003.

#### Other accessories

Description	Sold in lots of	Catalog number	Weight kg
Key for screwing in/unscrewing Ø18 mm cylindrical tag	5	XGSZ05	0.011 (0.024)
Identification legend for 23 x 4 mm connecting cables	200	XGSZ08MKW	0.056 (0.123)

### Compact stations (mm)

XGCS4901201

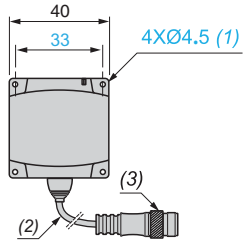
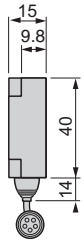

XGCS8901201

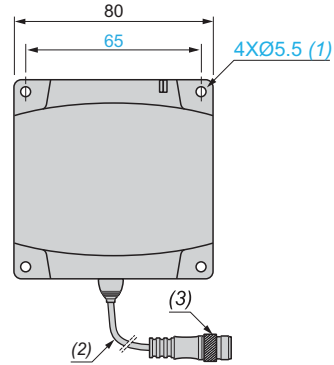
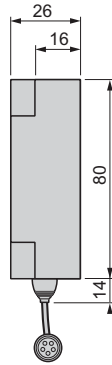

(1) For CHC type screws.

(2) Shielded cable (length: 20 cm).

(3) M12 5-pin male, A coding, connector.

### Read/write electronic tags (mm)

Square format tags

XGHB44345

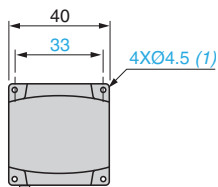
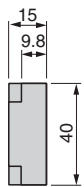

XGHB221346

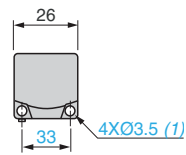
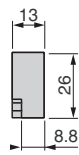

(1) For CHC type screws.

Rectangular format tags

XGHB90E340

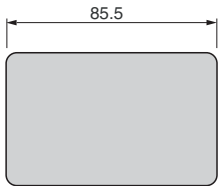
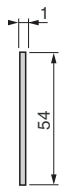

Cylindrical format tags

XGHB320345

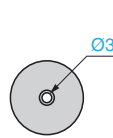

XGHB211345

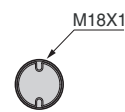

### Connection boxes (mm) (1)

Tap-off box TCSAMT31FP

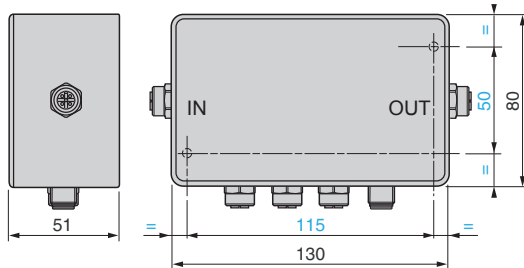

Ethernet box XGSZ33ETH

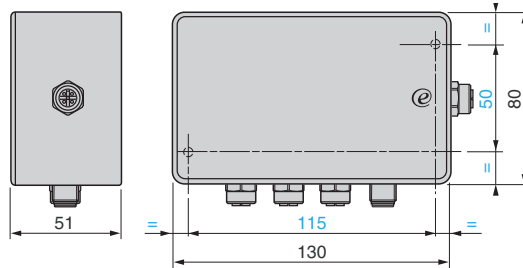

PROFIBUS box XGSZ33PDP

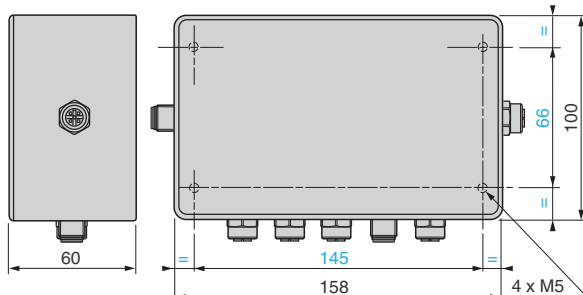

Mounting plate XGSZ3P

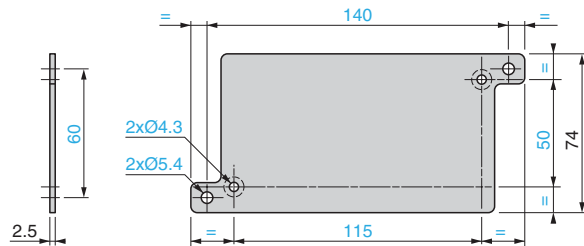

(1) Allow a 110 mm clearance zone for connecting the cables.

**Portable RFID diagnostics terminal (mm)**

XGSTP401

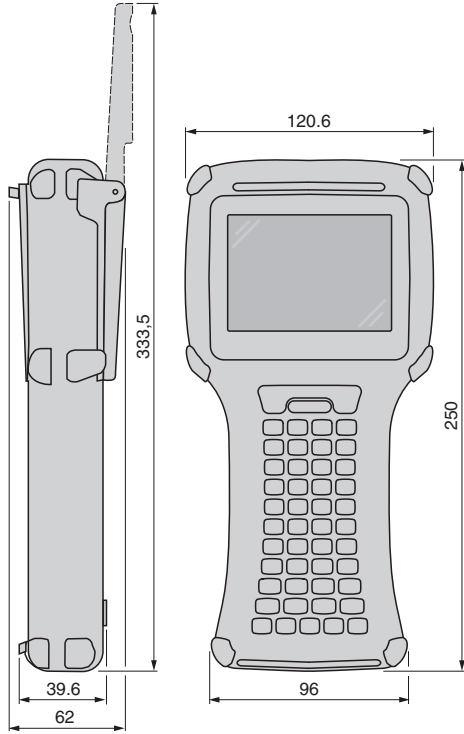

**Field expanders (mm)**

Conveying type XGSEC540

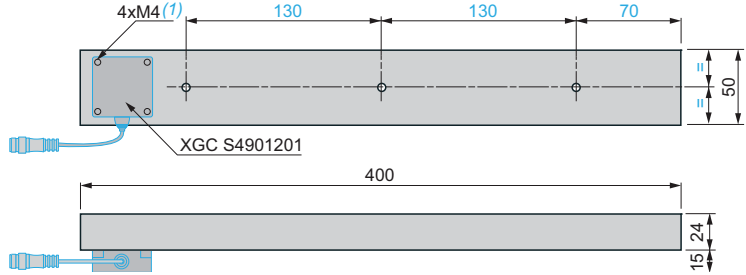

(1) Four M4 screws (included).

Universal type XGSEC2525

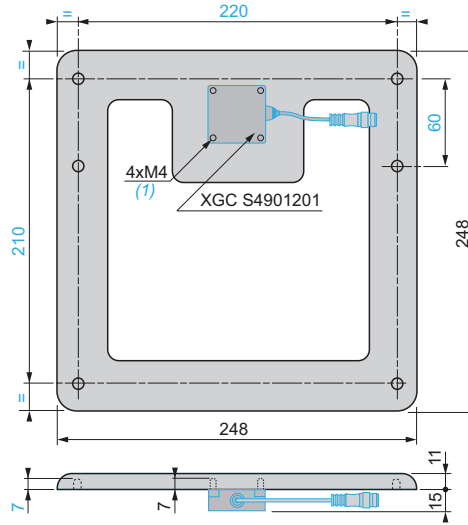

(1) Four M4 screws (included).

**Mounting brackets (mm)**

XSZBC90

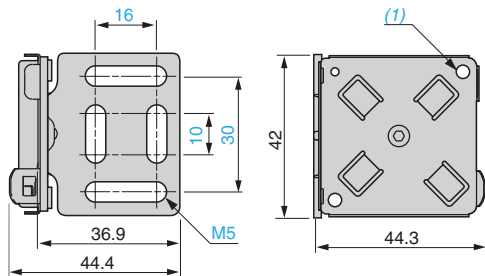

(1) Four M4 x 14 screws (included).

**Mounting plates (mm)**

XSZBC00

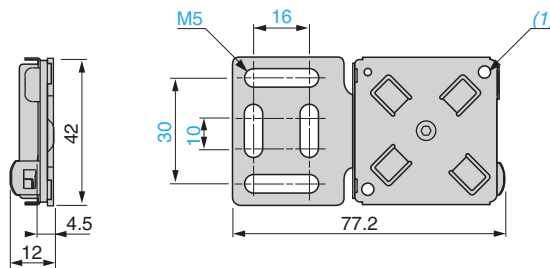

(1) Four M4 x 14 screws (included).

XSZBE90

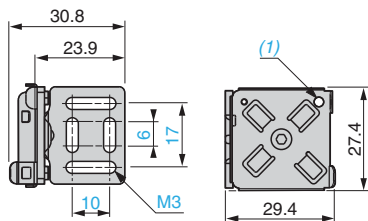

(1) Two M3 x 12 screws (included).

XSZBE00

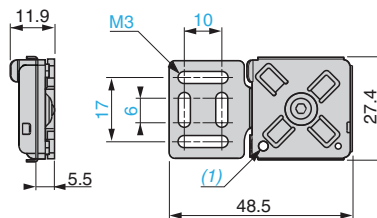

(1) Two M3 x 12 screws (included).

## Modbus connections

### XGCS stations ●901201

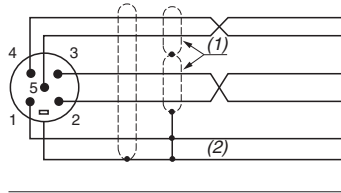

Pin no.	Station—Modbus signal
1	Drain (Modbus-SHLD)
2	⎓ +24 Vdc
3	0 V/Modbus-GND
4	D0
5	D1
Connector casing	Shielding

(1) Shielding per pair.  
(2) General cable shielding.

## Tap-off box TCSAMT31FP

### Socket to station cabling

Pin no.	Signal
1	– Drain (Modbus-SHLD)
2	⎓ +24 Vdc
3	0 V/Modbus-GND
4	D0
5	D1

### Socket to power supply cabling

Pin no.	Signal
1	⎓ +24 Vdc
2	⎓ +24 Vdc
3	⎓ 0 Vdc
4	⎓ 0 Vdc

### Socket to another connection box cabling

Pin no.	Signal
1	Drain (Modbus-SHLD)
2	–
3	0 V/Modbus-GND
4	D0
5	D1

### Socket to industrial PLC cabling

Pin no.	Signal
1	Drain (Modbus-SHLD)
2	–
3	0 V/Modbus-GND
4	D0
5	D1

## Cable connections

### TCS MCN1F●

Pin no.	Signal
1	– Drain (Modbus-SHLD)
2	Red ⎓ +24 Vdc
3	Black 0 V/Modbus-GND
4	White D0
5	Blue D1
Connector casing	Shielding

### XGS Z09L

Pin no.	Signal
1	Red ⎓ +24 Vdc
2	NC
3	Black ⎓ 0 Vdc
4	NC

## Ethernet connection

### Ethernet box XGSZ33ETH

#### Socket to station cabling

Pin no.	Signal
1	– GND
2	⎓ +24 Vdc
3	0 Vdc
4	D0
5	D1

#### Socket to power supply cabling

Pin no.	Signal
1	⎓ +24 Vdc
2	⎓ +24 Vdc
3	⎓ 0 Vdc
4	⎓ 0 Vdc

#### Cable XGSZ09L connections

Pin no.	Signal
1	Red ⎓ +24 Vdc
2	NC
3	Black ⎓ 0 Vdc
4	NC

#### Ethernet socket connection

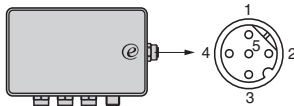

#### Cable TCS ECL1M3M●●S2

M12	Signal	Signal	RJ45
1	TD +	TD +	1
3	TD –	TD –	2
2	RD +	RD +	3
4	RD –	RD –	6

## PROFIBUS-DP connection

### PROFIBUS box XGSZ33PDP

#### Socket to station cabling

Pin no.	Signal
1	GND
2	⎓ +24 Vdc
3	0 Vdc
4	D0
5	D1

#### Socket to power supply cabling

Pin no.	Signal
1	⎓ +24 Vdc
2	⎓ +24 Vdc
3	0 Vdc
4	0 Vdc

#### PROFIBUS-DP network connections

Input	Output	Pin no.	Signal	Description
1	1	1	VP	Line terminator polarisation
2	1	2	RxD/TxD-N	Receive/transmit data (-) (red wire)
3	4	3	DGND	GND PROFIBUS
4	2	4	RxD/TxD-P	Receive/transmit data (+) (green wire)
		5	Shielding	Shielding or GND
		Connector casing	Shielding	Shielding or GND

#### Detection zones of compact stations

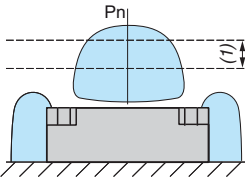

(1) Recommended crossing zone: between 0.4 and 0.8 Sn.

#### Angular positioning between station and tag

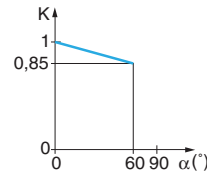
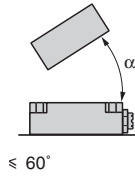

K = correction coefficient to be applied to the nominal sensing distance. Read distance = nominal sensing distance x K.

### Station and tag selection according to passing speeds

#### Read time with station XGC S49●●●●●

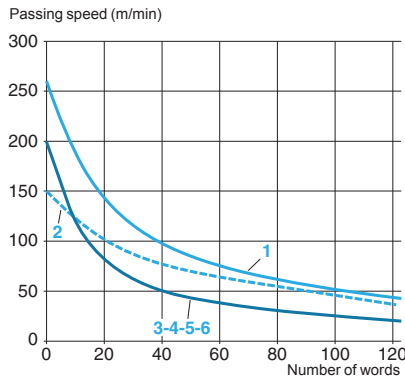

#### Write time with station XGC S49●●●●●

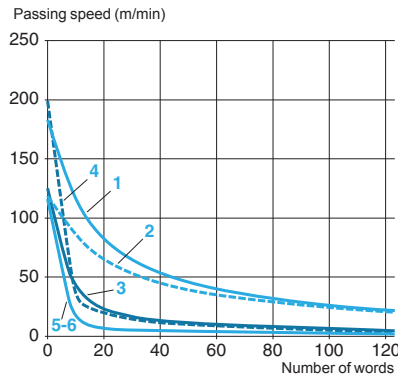

- 1 XGHB444345
- 2 XGHB445345
- 3 XGHB211345
- 4 XGHB320345
- 5 XGHB90E340
- 6 XGHB221346

#### Read time with station XGC S89●●●●●

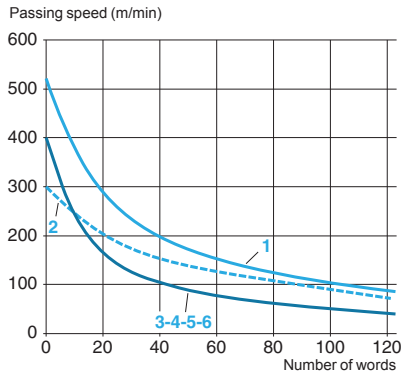

#### Write time with station XGC S89●●●●●

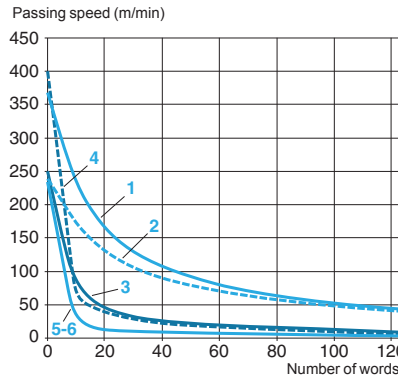

- 1 XGHB444345
- 2 XGHB445345
- 3 XGHB211345
- 4 XGHB320345
- 5 XGHB90E340
- 6 XGHB221346

#### Application example

#### Read time with station XGC S49●●●●●

On an assembly line, the object passing speed is 100 m/min. The application requires that 60 words be read.

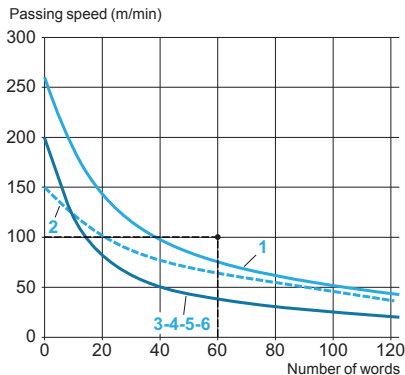

#### Write time with station XGC S89●●●●●

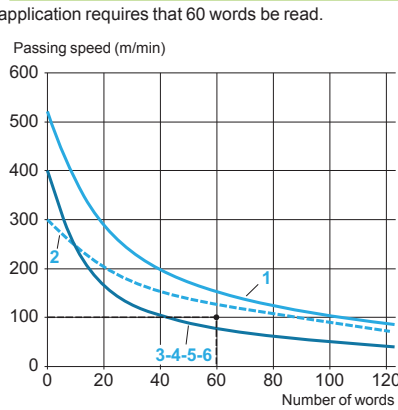

- 1 XGHB444345
- 2 XGHB445345
- 3 XGHB211345
- 4 XGHB320345
- 5 XGHB90E340
- 6 XGHB221346

Station XGC S49 cannot be used; no OsiSense® XG tag can be read under these conditions (Speed/Number of words).

Station XGC S89 can be used; only tags XGHB444345 and XGHB445345 meet the requirements (Speed/Number of words).

**Dialog zones for field expanders**

**Field expander + electronic tag**

**XGFEC540 + XGHB90E340**

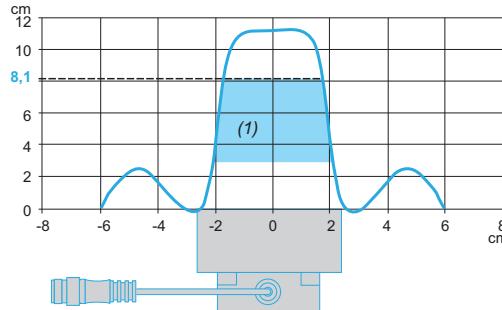
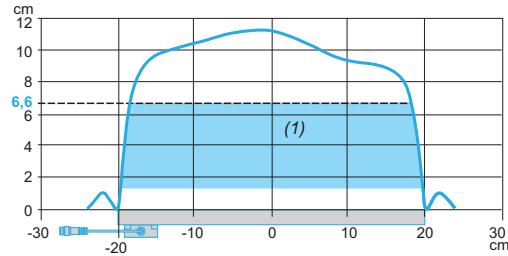

(1) Recommended working zone.

**XGFEC540 + XGHB320345**

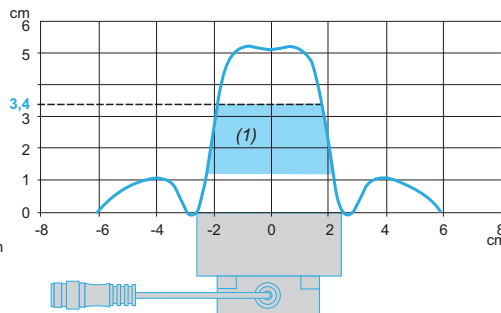
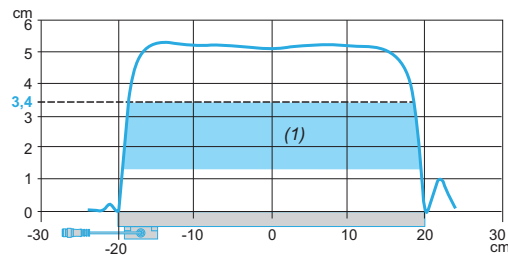

(1) Recommended working zone.

**XGFEC2525 + XGHB90E340**

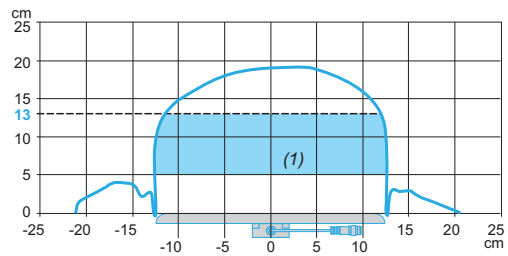

**XGFEC2525 + tag XGHB320345**

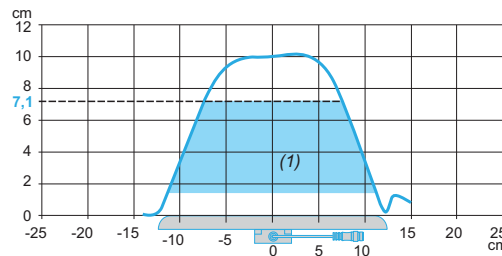

(1) Recommended working zone.

**Minimum mounting distances between system components**

**Distance between stations (mm)**

Minimum distance between 2 identical stations in relation to their positioning and the type of tag used

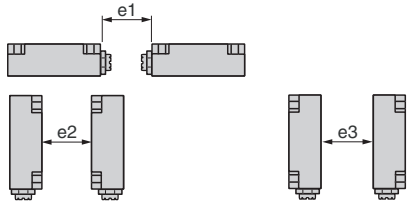

Tag	Flat form 40 XGCS4 station			Flat form 80 XGCS8 station		
	e1	e2	e3	e1	e2	e3
XGHB90E340	310	550	120	430	750	280
XGHB221346	200	320	100	280	530	260
XGHB320345	140	360	110	310	540	240
XGHB211345	210	180	60	200	370	170
XGHB444345	90	190	30	310	400	160
XGHB445345	110	170	30	310	380	160

**Distance between field expanders**

Minimum distance between 2 field expanders in relation to their positioning and the type of tag used

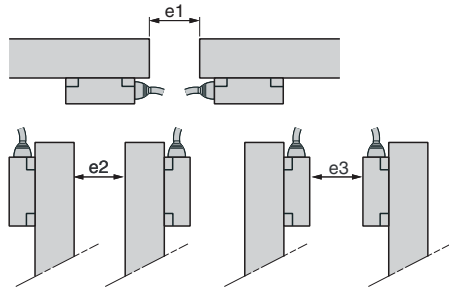

Tag	Field expander XGFEC540			Field expander XGFEC2525		
	e1	e2	e3	e1	e2	e3
XGHB90E340	195	285	195	570	890	960
XGHB320345	420	540	450	720	1275	1200

**Distance between tags (mm)**

Minimum distance between 2 identical tags in relation to their positioning and the type of station used

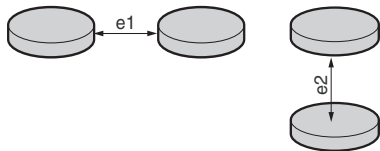

Tag	Flat form 40 XGCS4 station		Flat form 80 XGCS8 station	
	e1	e2	e1	e2
XGHB90E340	35	60	110	140
XGHB221346	50	10	120	50
XGHB320345	70	50	190	60
XGHB211345	40	10	120	20
XGHB444345	20	10	70	40
XGHB440245	—	—	60	10
XGHB440845	—	—	60	10
XGHB443245	—	—	60	10
XGHB445345	10	10	60	10
XGHB320246	—	—	60	10

**Minimum permissible mounting distances in a metal structure**

**Stations and tags**

XGCS stations 49/89 and  
Tags XGHB221346/B444345/B445345

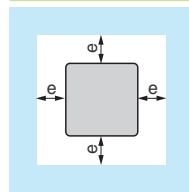

e ≥ 20 mm.



e ≥ 20 mm.

Tag XGHB320345

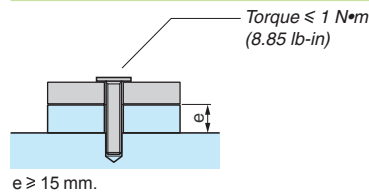

e ≥ 15 mm.

Tags XGHB90E340 and XGHB211345

No metal parts within 25 mm of the tag.

**Field expanders**

	e (mm)	h (mm)
XGFEC540	15	30
XGFEC2525	0	75

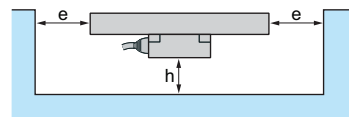

**Sensing distance**

Tags	Nominal sensing distance, mm (in.)		Reduced sensing distance with the presence of metal, mm (in.)	
	XGCS49	XGCS89	XGCS49	XGCS89
XGHB90E340	70 (2.76)	100 (3.94)	58 (2.28)	80 (3.15)
XGHB221346	40 (1.57)	55 (2.17)	30 (1.18)	33 (1.30)
XGHB320345	48 (1.89)	65 (2.56)	45 (1.77)	56 (2.20)
XGHB211345	18 (0.71)	20 (0.79)	16 (0.63)	15 (0.59)
XGHB444345	33 (1.30)	48 (1.89)	28 (1.10)	34 (1.34)
XGHB440245	45 (1.77)	65 (2.56)	30 (1.18)	45 (1.77)
XGHB440845	—	39 (1.54)	—	28 (1.10)
XGHB443245	—	39 (1.54)	—	28 (1.10)
XGHB445345	30 (1.18)	40 (1.57)	24 (0.94)	28 (1.10)
XGHB320246	45 (1.77)	65 (2.56)	—	28 (1.10)

---