

Twin Line

Motion control

Catalogue
June

2003



Telemecanique

Twin Line range

- Presentation page 2
- Associations of SER brushless motors and Twin Line servodrives page 3

Twin Line TLD 13 servodrives for servomotors

- Presentation, functions, characteristics pages 4 to 7
- References, dimensions pages 8 and 9
- Interfaces modules pages 10 and 11

Twin Line TLC 43/53/63 servodrives

- Presentation pages 12 and 13

Twin Line TLC 43 servodrives

- Functions pages 14 and 15
- Presentation, characteristics pages 16 and 17
- References, dimensions pages 18 and 19

Twin Line TLC 53 servodrives

- Functions pages 20 and 21
- Presentation, characteristics pages 22 and 23
- References, dimensions pages 24 and 25

Twin Line TLC 63 servodrives

- Functions pages 26 to 29
- Presentation, characteristics pages 30 and 31
- References, dimensions pages 32 and 33

Interfaces and separate components

- Interfaces modules for TLC 43/53/63 servodrives pages 34 and 35
- Separate components for TLD/TLC servodrives pages 36 to 41

SER brushless motors for Twin Line servodrives

- Presentation, functions, description pages 42 to 44
- Characteristics pages 45 to 59
- References, dimensions pages 60 to 63
- Holding brake and encoder pages 64 to 67

Services

- Automation product certifications pages 68 and 69
- Community regulations and protective treatment page 70
- Product references index page 71
- Schneider Electric worldwide pages 72 to 75

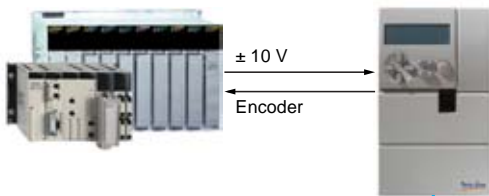

Twin Line servodrives and SER brushless motors are the latest additions to the Schneider Electric range of motion control products.

In response to the demands of an ever widening range of industrial applications, we have created the most flexible servodrives possible, so that they can be economically integrated into machine designers' preferred architectures.

Twin Line TLD and TLC servodrives Control built-in to PLC

Premium and Quantum automation platforms offer, as part of their interface ranges, axis control modules with analog outputs for position control functions: TSX CAY, multi-axis control modules (2 to 4 axes), or 140 MSB 10100 single-axis control modules.

These modules, associated with Twin Line **TLD 13** modules, offer unequalled ease of integration and installation of motion control (intelligent position control) in the automation sequence.

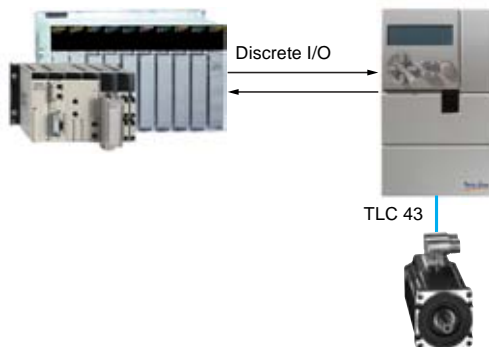

Discrete control

Twin Line **TLC 43** servodrives are fitted with a position controller that can be easily controlled via the discrete input/output lines of a PLC.

This simple configuration, offering all the precision of Twin Line servodrives, is for applications involving a small number of axes, with little synchronization and rarely requiring adjustment of servodrive settings.

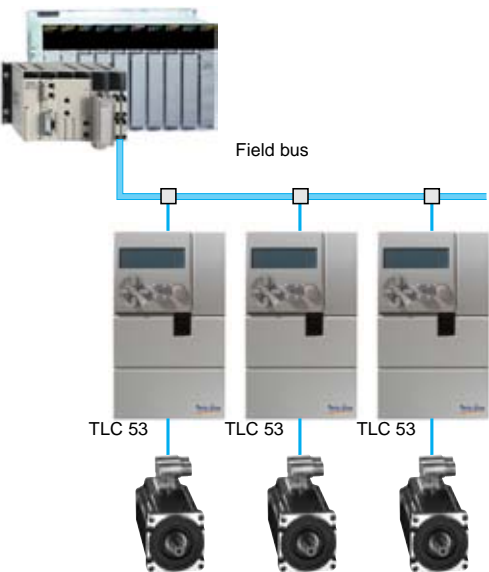

Control by industrial field bus

The Twin Line **TLC 53** range of servodrives offers, in addition to built-in position control in the servodrive, a wide choice of communication bus connections. This possibility of communication via industrial field buses widens the range of applications by facilitating remote adjustment and maintenance operations.

Programmable motion controller

In order to respond to applications which also require straightforward sequential control with field bus inputs/outputs, Twin Line **TLC 63** servodrives are motion controllers which can be programmed in graphic or textual automation languages, compliant with the standard IEC 61131-3.

The Twin Line **TLC 63 ▲** servodrive naturally occupies the master position of multi-axis applications managed by Twin Line TLC 53 servodrives.

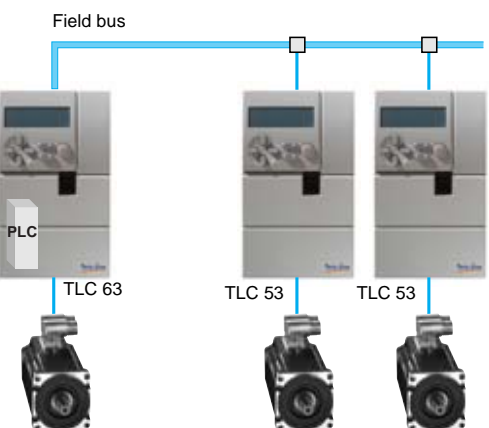

SER brushless motors

The technology of **SER** brushless motors means they are well-suited to the most demanding dynamic and precision applications within continuous torque ranges from 0.3 to 13.4 Nm.

They are fitted with a thermal probe protection system and a single turn or multiturn SinCos Hiperface integrated sensor.

Depending on the model, they are fitted with:

- Failsafe holding brake.
- IP 41 or IP 56 degree of protection.
- Gearboxes of ratio 3:1, 5:1 or 8:1.

▲ Commercial launch planned for 3rd quarter of 2003.

SER brushless motors
(IP 41 or IP 56)



Twin Line TLD and TLC servodrives
(IP 20 or IP 54)



	TL032	TL034	TL036	TL038
	3 A / 750 W single phase	3 A / 1.5 kW 3-phase	6 A / 3 kW 3-phase	16 A / 8 kW 3-phase

SER 364 3L 3S	12,000 rpm (1)	0.3/0.8 Nm			
SER 364 3L 5S		0.3/1.1 Nm			
SER 364 3L 7S		0.3/1.3 Nm			
SER 366 3L 3S		0.5/1.1 Nm			
SER 366 3L 5S		0.5/1.6 Nm			
SER 366 3L 7S		0.5/2.1 Nm			
SER 368 3L 3S		0.7/1.5 Nm			
SER 368 3L 5S		0.7/1.9 Nm			
SER 368 3L 7S		0.7/3 Nm			
SER 36A 3L 3S		0.7/1.5 Nm			
SER 36A 3L 5S		0.9/2.1 Nm			
SER 36A 3L 7S		0.9/3.6 Nm			
SER 39A 4L 3S	6000 rpm (1)	1.1/2.4 Nm			
SER 39A 4L 7S		1.1/4 Nm	1.1/4 Nm		
SER 39B 4L 3S		4.2/2.2 Nm	4.2/2.2 Nm	7.8/2.2 Nm	
SER 39B 4L 7S		8/2.2 Nm	8/2.2 Nm		
SER 39C 4L 3S		2.3/4.8 Nm	2.3/4.8 Nm	2.9/11.5 Nm	
SER 39C 4L 5S		2.9/6.8 Nm	2.9/6.8 Nm	2.9/11.5 Nm	
SER 39C 4L 7S		2.9/11.5 Nm	2.9/11.5 Nm		
SER 39D 4L 5S		3.1/6.4 Nm	3.1/6.4 Nm	3.6/11.5 Nm	
SER 39D 4L 7S					
SER 3BA 4L 3S	6000 rpm (1)	2.3/4.6 Nm	2.3/4.6 Nm	4.6/14.5 Nm	4.6/18 Nm
SER 3BA 4L 5S		4.3/7.6 Nm	4.3/7.6 Nm	4.6/18 Nm	
SER 3BA 4L 7S		4.6/12.8 Nm	4.6/12.8 Nm	4.6/18 Nm	
SER 3BB 4L 3S		3/6 Nm	3/6 Nm	6/19 Nm	6.6/25 Nm
SER 3BB 4L 5S		4/8 Nm	4/8 Nm	6.6/19.5 Nm	6.6/23 Nm
SER 3BB 4L 7S		6.6/15 Nm	6.6/15 Nm	6.6/25 Nm	
SER 3BC 4L 5S	4500 rpm (1)	4.3/8.5 Nm	4.3/8.5 Nm	8.5/27 Nm	10/38 Nm
SER 3BC 4L 7S		8.3/16.5 Nm	8.3/16.5 Nm	10/38 Nm	10/38 Nm
SER 3BD 4L 5D				8.7/26.8 Nm	13.4/40 Nm
SER 3BD 4L 7S		7.9/15.7 Nm	7.9/15.7 Nm	13.4/39 Nm	13.4/48 Nm

0.3/0.8 Nm
Selected example: the motor

The 1st value corresponds to the continuous stall torque, 2nd value corresponds to the peak stall torque
SER 364 3L 3S associated with the servodrive **TL032** answers to the demands of applications

requiring at most 0.3 Nm of continuous stall torque, 0.8 Nm of peak torque and a maximum mechanical speed of 12,000 rpm.

(1) Maximum mechanical speed.

Motion control

Twin Line TLD 13 servodrives for servomotors



TLD 132/134



TLD 136/138

Presentation

Twin Line TLD 13 servodrives are specially designed for use with brushless motors. They are controlled by a setpoint voltage ± 10 V, in association with an axis control module (for example TSX CAY or 140 MSB 10100). They offer 11 discrete inputs (8 fixed allocation inputs, 2 limit switch detector inputs and 1 STOP function input) and 4 discrete outputs (3 fixed allocation outputs and 1 output for the brake control via the TLA BHO holding brake controller). Depending on the parameter settings, the servodrive operates in speed controller, current controller or electronic gearbox mode.

Twin Line TLD 13 servodrives for servomotors are available in the following models:

- TLD 132: 3 A/750 W/230 V single phase.
- TLD 134: 3 A/1.5 kW/230...480 V 3-phase.
- TLD 136: 6 A/3 kW/230...480 V 3-phase.
- TLD 138: 16 A/8 kW/230...480 V 3-phase.

The principal characteristics of Twin Line TLD 13 servodrives are:

- The servodrive is powered directly from the mains supply, without a transformer (TT and TN grounding systems only).
- Built-in power supply EMC input filter, radiator and fan.
- Built-in brake power dissipation function.
- All electrical connections can be accessed via the front panel.
- Small and compact size.
- IP 20 degree of protection.

In addition, Twin Line TLD 13 servodrives:

- Accept SinCos Hiperface or resolver motor encoder returns.
- Can manage an external brake controller.

Choice of servodrive references

Nota : *Twin Line TLD 13 servodrives cater for a wide range of application needs. These functions and interfaces must be identified and defined when ordering each servodrive.*

Functions

Parameter settings

The TLA PH OO operator interface (1) or the TLA PS CA commissioning tool (1), which runs on Windows 98/NT/XP, enables the parameter definition of a complete servodrive and servomotor assembly as well as the copying of the parameters from one servodrive to another.

Operating modes

TLD 13 servodrives can be operated in four modes:

- Manual operation, with manual movement.
- Automatic operation with current regulator.
- Automatic operation with speed regulator.
- Automatic operation in electronic gearbox mode.

Manual movement

In this mode, the servodrive operates as a speed controller. This mode can be activated by:

- The TLA PS CA commissioning tool.
- The TLA PH OO operator interface.
- Discrete inputs, with 2 possible movement speeds.

Speed or current control

Speed or current control is active in automatic mode. The command value, within a range of ± 10 V, is received on the analog input of the servodrive.

Electronic gearbox

In electronic gearbox mode, the servodrive calculates a new position setpoint from a movement command and a variable reduction factor. This operating mode is selected when the position of one or more motors is required to follow the master signal of an automation device or encoder.

In electronic gearbox mode, the servodrive must be fitted to the M1 slot, with either an RS 422-C encoder module or a PULSE-C module for pulse/direction signals or for forward/reverse pulse signals.

Change of operating mode

It is possible to change from one operating mode to another while movement is in progress. The servodrive switches, without the motor being stopped, from one automatic operating mode to another. To change from manual mode to automatic mode, it stops the motor briefly and activates the drive parameters and the settings specific to the selected operating mode.

(1) Product to be ordered separately, see page 38.

Motion control

Twin Line TLD 13 servodrives for servomotors

Functions (continued)

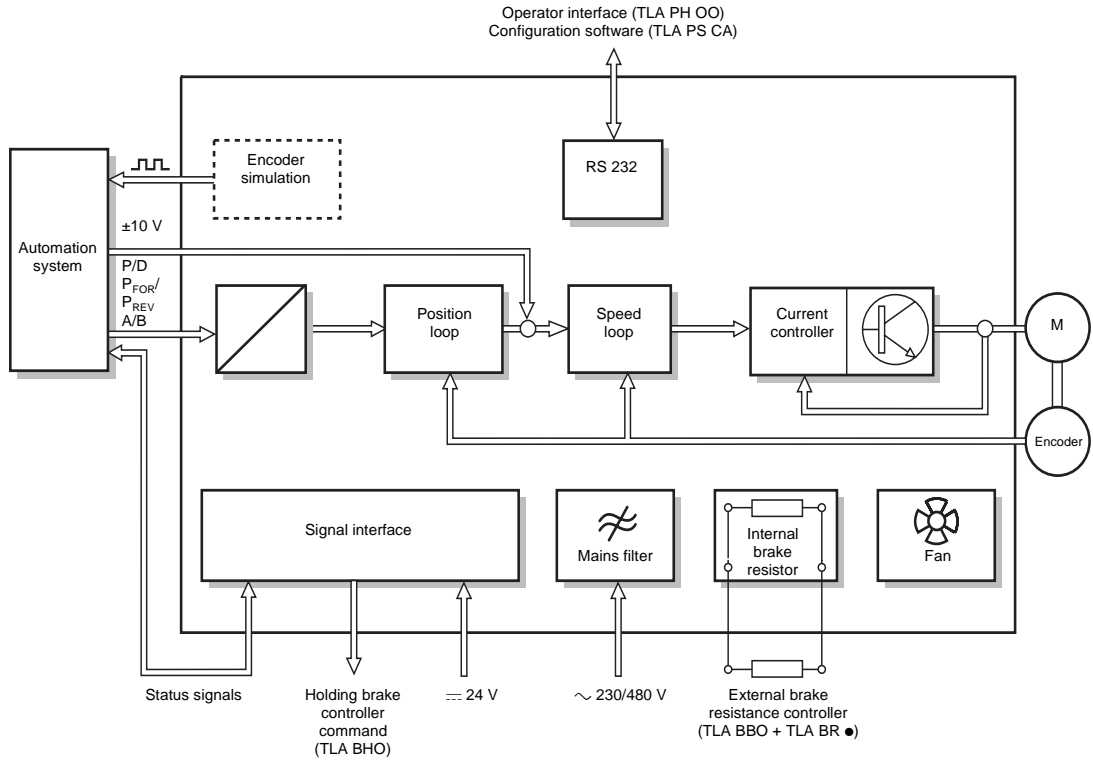

Environment conditions		
Ambient temperature	°C	0...50
Storage temperature	°C	- 40...+ 70
Relative humidity		15...85 %, non-condensing
Altitude	m	< 1000
Degree of protection		IP 20

Electrical characteristics			TLD 132	TLD 134	TLD 136	TLD 138	
Type of servodrive							
Power supply	Mains voltage	V	~ 1 x 230 (- 20 %)... 240 (+ 10 %) / ~ 3 x 230 (- 20 %)...480 (+ 10 %)				
	Mains frequency	Hz	47...63				
	Consumption	A	6.5	4	7.5	20	
	Inrush current	A	< 60				
	aM type external fuse	A	10				25
Motor	Rated power	kW rms	0.75	1.5	3	8	
	Continuous current (1)	A rms	3			6	16
	Current peak value over 5 s max.	A rms	6			20	32
	Switching frequency	kHz	8/16			4/8	
Motor cable	Cable length	m	≤ 20				
	Shielding connection		At each end				
	Cross-section (depending on the length)	mm ²	1.5	1.5...2.5		2.5...4	
Continuous power bus connection			Maximum of two servodrives of the same power connected in parallel				
Internal brake resistance	Continuous operation	W	30	50	200	80	
	Maximum unit brake power	J	50	80	100	130	
Supply voltage $\overline{\text{---}}$ 24 V TBTS, DIN 19240,	Input voltage	V	20...30 unprotected against polarity inversions				
	Input ripple	V	< 2 (peak to peak)				
	Nominal input current	A	< 2.5				
Inputs (uninsulated)	Number of inputs		11 (8 fixed allocation inputs, 2 limit-switch detector inputs, 1 STOP function input)				
	Voltage at 1	V	$\overline{\text{---}}$ 12...30 (I ≥ 3 mA)				
	Voltage at 0	V	$\overline{\text{---}}$ ≤ 5 (I ≤ 0.5 mA)				
	Current	mA	≤ 7 under $\overline{\text{---}}$ 24 V				
	Filtering	ms	0.7...1.5				
Outputs (protected against short-circuits)	Number of outputs		4 (3 fixed allocation outputs, 1 brake control output via the TLA BHO holding brake controller)				
	Voltage	V	$\overline{\text{---}}$ ≤ 30				
	Load current	mA	≤ 400				
	Voltage drop at 400 mA	V	$\overline{\text{---}}$ ≤ 1				
	Supporting inductive load	mH	150 /11 W				
Analog input	Voltage	V	± 10				
	Input resistance	kΩ	5				
	Resolution	bits	12				

(1) rms value in continuous operation at maximum ambient temperature.

Motion control

Twin Line TLD 13 servodrives for servomotors



TLD 132 2F2 ●●1●1
(3)



TLD 138 2F3 ●●1●1
(3)

References (1)

IP 20 degree of protection

Servodrive supply	Power	Power supply EMC input filter	Reference (2)	Weight kg
~ 230 V single phase 50/60Hz	0.750 kW	Built-in	TLD 132 2F2 ●●1●1	2.700
~ 230...480 V 3-phase 50/60 Hz	1.5 kW	Built-in	TLD 134 2F3 ●●1●1	3.700
	3 kW	Built-in	TLD 136 2F3 ●●1●1	6.600
	8 kW	Built-in	TLD 138 2F3 ●●1●1	10.800

(1) For connection cables and accessories, see pages 38 at 41.

(2) To order a TLD 13 servodrive, fill out each reference

TLD 13● 2F●		●	●	1	●	1
M1 Slot Position setpoint	Without module	1				
	RS 422-C Encoder module	2				
	PULSE-C Module	3				
M2 Slot Position feedback	Sincos Hiperface		2			
	Resolver (4)		3			
M3 Slot	Without module			1		
M4 Slot Communication	Without module					1
	ESIM1-C Module					2
	ESIM2-C Module					3
	SSI-C Module					4
-	-					1

For detailed module specifications, see page 10.

(3) The TLA PH OO operator interface is to be ordered separately, see page 38.

(4) Not compatible with SER motors in this catalog.

Dimensions (in mm)

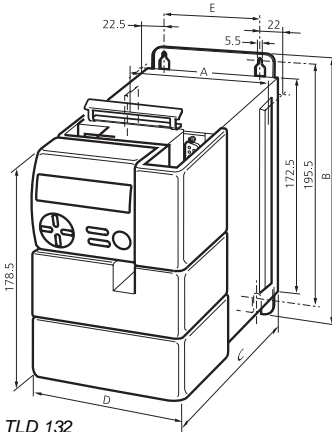

TLD 132
TLD 134

	TLD 132	TLD 134
A	108	128
B	212.5	212.5
C	184.5	214.5
D	105.5	125.5
E	63	83

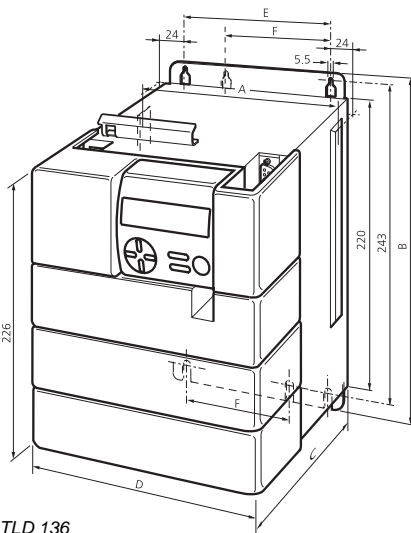

TLD 136
TLD 138

	TLD 136	TLD 138
A	178	248
B	260	260
C	244.5	244.5
D	176	246
E	130	200
F	—	120

Motion control

Twin Line TLD 13 servodrives

Interface modules

Presentation

Interface modules for Twin Line TLD 13 servodrives allow a configuration adapted to the application to be defined using the servodrive. See page 8.

RS 422-C module: encoder interface

The RS 422-C module receives signals from an external encoder in the form of A/B signals. It also uses the reference pulse. The electronic gearbox function is a typical application.

PULSE-C Module: pulse interface

The PULSE-C module receives position data in the form of a pulse/direction signal or a forward/reverse pulse signal. The electronic gearbox function is a typical application.

HIFA-C Module: SinCos Hiperface interface

The HIFA-C module receives the position information from a motor fitted with a single turn or multiturn SinCos Hiperface absolute encoder (4096 revolutions). The position of the rotor is detected optically and transmitted to the HIFA-C module in the form of analog and digital position data. The signals are decoded with 14 bit resolution, corresponding to 16 384 pulses/revolution. The built-in digital interface allows initial position information, as well as all the motor parameters of the SinCos encoder memory, to be transmitted to the servodrive.

SSI-C Module: SSI encoder emulation

The SSI-C module supplies the absolute position of the motor to an axis control system via a synchronous serial interface. The resolution transmitted is of 4096 pulses/revolution for 4096 revolutions (24 bits).

ESIM1-C Module: encoder simulation

The ESIM1-C module supplies the position data of the motor in the form of incremental signals. These are two electrical quadrature phase signals (channels A/B), as well as the shiftable reference pulse (Z pulse). The transmitted resolution is 4096 revolutions/turn.

ESIM2-C Module: double encoder simulation

The module ESIM2-C supplies the A/B signals and reference pulse on 2 connectors in parallel. A typical application is the connection of a second servodrive, in electric shaft mode (electronic gearbox).

Motion control

Twin Line TLD 13 servodrives

Interface modules

Characteristics			
Type of interface module		RS 422-C	
Inputs	Type		RS 422, electrical connection to --- 24 V ground
	Input frequency	kHz	≤ 400
Outputs	External encoder supply	V	5 ± 5 %, 300 mA max., protected against short-circuits and overloads
	Cable length	m	100 max.
	Minimum cross-section	mm²	0.5 for supply 0.25 for signals
Type of interface module		PULSE-C	
Inputs	Type	V	RS 422, or 4.5...30 open collector Electrical connection to --- 24 V ground
	Input resistance	kΩ	5
	Pulse frequency	kHz	≤ 200
	Enable input frequency	kHz	≤ 1
Outputs	Type		Protected against short-circuits with open collector
	Output voltage	V	≤ 30
	Output current	mA	≤ 50
Connections	Length with RS 422 connection	m	100 max.
	Length, connected to open collector	m	10 max.
	Minimum cross-section	mm²	0.14 for signal
Type of interface module		SSI-C	
Outputs	Type		RS 422, electrical connection to --- 24 V ground
	Frequency		53 kHz...2 MHz
Type of interface modules		ESIM1-C	ESIM2-C
Outputs	Type	RS 422, electrical connection to --- 24 V ground	RS 422, electrical connection to --- 24 V ground, signals A, B, I in parallel on two connectors

Motion control

Twin Line TLC 43/53/63 servodrives



TLC 432/532/632
(IP 20)



TLC 438/538/638
(IP 20)

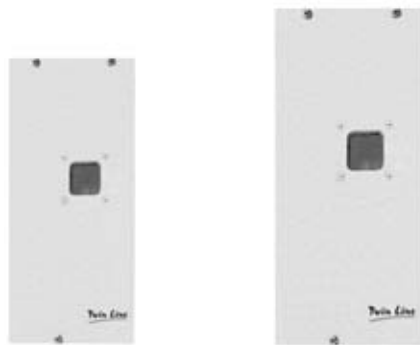

TLC 434/534/634
(IP 54)

Presentation

Twin Line TLC 43/53/63 servodrives integrate, in addition to power electronics for brushless motors, a position system with 3 options, offering different levels of intelligent functions.

The higher-level automation system accesses:

- Drive parameters.
- The internal status.
- The indexer function via a discrete interface, serial link or field bus.

The architectures supported by this type of servodrive:

- Discharge the automation system from having to perform position and control functions for brushless motors.
- Allow automation systems to be easily extended (flexible architectures).
- Facilitate maintenance operations, by downloading of initial parameters from the automation device.
- Simplify wiring of installations.

Twin Line TLC 43/53/63 servodrives are fitted with 2 fast capture inputs and 1 fast output, for the electronic cam function (2 x 64 switching points max.). A device for limiting vibrations during positioning protects its mechanical parts and prolongs the life of the machine.

The principal characteristics of Twin Line TLC 43/53/63 servodrives are:

- Power range: from 750 W to 8 kW.
- The servodrive is powered directly from the mains supply, without a transformer (TT and TN grounding systems only).
- Built-in EMC power supply input filter, radiator and fan.
- Built-in brake power dissipation function.
- All electrical connections can be accessed via the front panel.
- Small and compact size.
- IP 20 or IP 54 degree of protection depending on the model.

Discrete inputs/outputs

The 18 inputs and 7 outputs of the TLC 43/53/63 servodrives vary in their characteristics and use according to the operating mode selected. See table below.

Operating mode	Type of inputs/outputs	TLC 43	TLC 53	TLC 63
Definition of the network address (IO-Mode = 0)	Discrete inputs	3 position detector inputs 1 STOP function input		
		14 inputs (network address)	12 inputs (network address)	
	Fast inputs (1)	–	2 inputs	
	Discrete outputs	5 outputs available to the automation system 1 brake control output (2)		
	Fast output (3)	1 output		
Discrete inputs/outputs available to the automation system	Discrete inputs	3 position detector inputs 1 STOP function input		
		14 inputs (available to the automation system)	12 inputs (available to the automation system)	
	Fast inputs (1)	–	2 inputs	
	Discrete outputs	5 outputs available to the automation system 1 brake control output (2)		
	Fast output (3)	1 output		
Discrete fixed allocation inputs/outputs	Discrete inputs	3 position detector inputs 1 STOP function input		–
		14 fixed allocation inputs	13 fixed allocation inputs	–
	Fast input (1)	–	1 input	–
	Discrete outputs	5 fixed allocation outputs 1 brake control output (2)		–
		Fast output (3)	1 output	

(1) Maximum response time of 30 μs.
(2) Via the TLA BHO holding brake controller.
(3) Maximum response time of 150 μs.

In addition, the Twin Line TLC 43/53/63 servodrives are:

- Configurable using:
 - an TLA PH OO operator interface (1),
 - a TLA PS CA commissioning tool (1), running Windows 98/NT/XP operating systems,
 - a TLA PS PB programming software (1), (for servodrive TLC 63 only) in languages complying with the standard IEC 61131-3.
- Compatible with SinCos Hiperface or resolver type motor encoder returns.
- Designed to manage an external brake controller.

Possible communication interfaces are:

- RS 485 serial link.
- CANopen (DS-402 profile) or DeviceNet buses.
- INTERBUS bus.
- Profibus DP bus.

Choice of servodrive references

Nota : Twin Line TLC 43/53/63 servodrives cater to a wide range of application needs. **These functions and interfaces must be identified and defined when ordering each servodrive.**

Built-in protection systems

The following protection systems are built into TLC 43/53/63 servodrives:

- Monitoring of the servodrive or motor temperature (PTC probe).
- Detection of grounding.
- Detection of faults and phase short circuits.
- Monitoring of intermediary circuit voltage.

The robust integration of components such as the EMC supply input filter, radiator, fan, brake resistance and holding brake control facilitate its installation.

(1) To be ordered separately, see page 38.

Functions

Twin Line TLC 43 servodrives with built-in position control via discrete inputs/outputs are equipped with 64 movement blocks (50 free blocks and 14 allocated blocks).

There are three possible operating modes defined using the configuration software:

- Controlling the built-in position controller via the discrete inputs/outputs of the servodrive. A communication interface is not required for this operating mode.
- Controlling the built-in position controller using a communication interface (slot M4). The discrete inputs/outputs are used to define the address and speed of the communication interface.
- Controlling the built-in position controller using a communication interface (slot M4). The discrete inputs/outputs are available to the automation system.

Operation by block

Each block defines a movement with speed control that can be carried out according to 2 modes of operation:

- Point-to-point position control.
- Speed controller.

A point-to-point position control block defines the following information:

- relative or absolute movement,
- target position,
- target speed,
- acceleration and deceleration ramps.

A movement block in speed control mode defines the following information:

- target speed,
- acceleration and deceleration ramps.

A complete range of controls is available:

- Operation by point-to-point movement block or in speed control mode.
- Parametering of electronic cam thresholds and direct activation/deactivation of outputs.
- Adjustment of acceleration and deceleration ramps.
- Reading or writing of the position.
- Triggering of a reference point movement.
- Reading and writing of all parameters.
- Activation and deactivation of outputs (regardless of mode).
- Reading of inputs (regardless of mode).
- Error processing.

Motion control

Twin Line TLC 43 servodrives

Point-to-point position control

In point-to-point position controller mode, a position control command defines a movement from a point A to a point B. The position may be absolute (with reference to the axis reference point) or relative (with reference to the current position).

Speed control

In speed control mode, a setpoint speed is attributed to the axis and a movement is launched without a pre-defined target position. The axis moves at this speed until another speed or operating mode is selected. The setpoint speed is modified immediately, even while a movement is in progress.

Reference point

A reference point operation allows a defined axis position to be allocated to a specific mechanical position. This is done either by directly allocating the real position, or by carrying out a reference point movement.

The different types of reference point are:

- With movement to the upper or lower limit switch, or on the reference point cam.
- With or without 0 pulse.

Manual movement

All manual movement, controlled by the operator, can be carried out via the discrete inputs/outputs or using the user interface TLA PH OO or the configuration software TLA PS CA.

Teach-in

The teach-in consists in recording the current position value in the selected memory space. This operation allows you to record up to:

- 2 x 64 absolute threshold positions for the electronic cam function.
- 50 position blocks for the built-in position controller.

Acceleration and deceleration ramps

A linear acceleration and deceleration ramp (which may be separate) can be defined for the position control of the motors. A bumpless acceleration or deceleration phase is possible due to a filtering device which can be activated at any time.

Quick-Stop

The quick-stop function enables the motor to be immobilized as quickly as possible. It is possible to select a linear braking ramp or a torque ramp (maximum motor current).



TLC 432 2F2
(IP 20)



TLC 438 2F3
(IP 20)



TLC 434 5F3
(IP 54)

Presentation

Twin Line TLC 43 servodrives for servomotors with built-in position controller and controlled via discrete inputs/outputs are available in the following models:

- IP 20 degree of protection:
 - TLC 432 2F2: 3 A/750 W/230 V single phase,
 - TLC 434 2F3: 3 A/1.5 kW/230...480 V 3-phase,
 - TLC 436 2F3: 6 A/3 kW/230...480 V 3-phase,
 - TLC 438 2F3: 16 A/8 kW/230...480 V 3-phase.

- IP 54 degree of protection:
 - TLC 432 5F2: 3 A/750 W/230 V single phase,
 - TLC 434 5F3: 3 A/1.5 kW/230...480 V 3-phase.

These IP 54 servodrives can be fitted with a built-in holding brake controller, depending on model.

An EMC supply input filter, radiator and fan are integrated as standard on all IP 20 and IP 54 servodrives.

Operating diagram

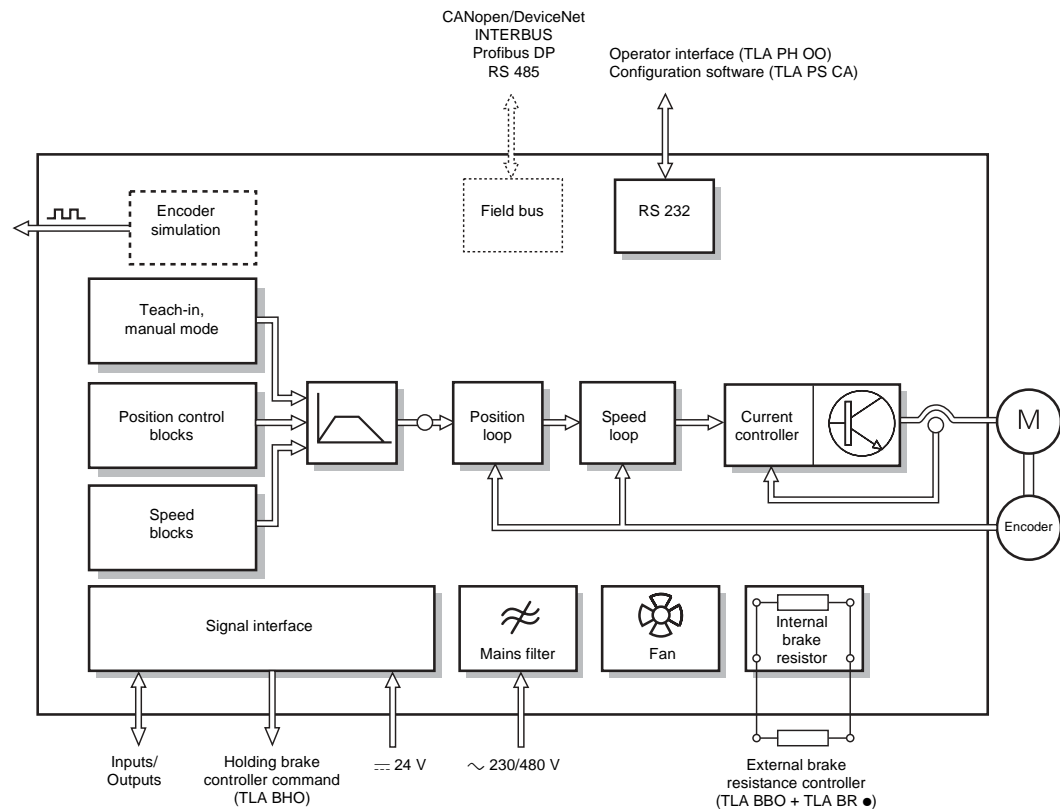

Environment conditions

Ambient temperature (1)	°C	0...+ 50 for IP 20 servodrives, 0...+ 45 for IP 54 servodrives
Storage temperature	°C	- 40...+ 70
Relative humidity		15 to 85 %, non-condensing
Altitude	m	< 1000
Standards and certifications	Products	UL 508 C
	Class of protection	Type 1 according to pr EN 50178
	Overvoltage	Category III according to pr EN 50178
	Pollution	Degree 2 according to pr EN 50178

Electrical characteristics

Type of servodrive		TLC 432 ●F2 1●●●●	TLC 434 ●F3 1●●●●	TLC 436 2F3 1●●●●	TLC 438 2F3 1●●●●	
Degree of protection according to DIN EN 60529		IP 20 (TLC 432 2F2) IP 54 (TLC 432 5F2)	IP 20 (TLC 434 2F3) IP 54 (TLC 434 5F3)	IP 20		
Power supply	Mains voltage	V	~ 1 x 230 (-20 %)...240 (+15 %)			
	Mains frequency	Hz	47...63			
	Consumption	A	6.5	4	7.5	20
	Inrush current	A	< 60			
	aM type external fuse	A	10			25
Motor	Rated power	kW rms	0.75	1.5	3	8
	Continuous current (2)	A rms	3		6	16
	Current peak value over 5 s max.	A rms	6		20	32
	Switching frequency	kHz	8/16			4/8
Motor cable	Cable length	m	≤ 20			
	Shielding connection		At each end			
	Cross-section (depending on the length)	mm²	1.5	1.5...2.5		4
Continuous power bus connection			Maximum of two servodrives of the same power connected in parallel			
Internal brake resistance (3)	Continuous operation	W	30	50	200	80
	Maximum unit brake power	J	50	80	100	130
Power supply --- 24 V TBTS, DIN 19240	Input voltage	V	20...30 V unprotected against polarity inversions			
	Input ripple	V	< 2 V peak to peak			
	Nominal input current	A	< 2.5			
Inputs (uninsulated)	Number of inputs		See page 12			
	Voltage at 1	V	--- 12...30 (I ≥ 3 mA)			
	Voltage at 0	V	--- ≤ 5 (I ≤ 0.5 mA)			
	Current	mA	≤ 7 under --- 24 V			
	Filtering	ms	0.7...1.5			
Outputs (protected against short-circuits)	Number of outputs	V	See page 12			
	Voltage	V	--- ≤ 30			
	Load current	mA	≤ 400			
	Voltage drop at 400 mA	V	--- ≤ 1			
	Supporting inductive load	mH	150 /11 W			
Analog input	Voltage	V	± 10			
	Input resistance	kΩ	5			
	Resolution	bits	10			

(1) For TLC 432 5F2 and TLC 434 5F3, operation outdoors or in a highly polluted environment is not recommended (clogging up of fan).

(2) rms value in continuous operation at maximum ambient temperature.

(3) For TLC 432 5F2 and TLC 434 5F3, depends on the ambient temperature and ventilation. Consult our regional office.

Motion control

Twin Line TLC 43 servodrives for servomotors



TLC 432 2F2 1
(3)



TLC 438 2F3 1
(3)

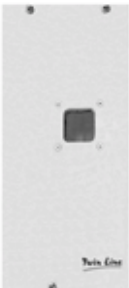

TLC 434 5F3 1

References (1)

IP 20 degree of protection

Servodrive supply	Power	Power supply EMC input filter	Reference (2)	Weight kg
~ 230 V single phase 50/60 Hz	0.750 kW	Built-in	TLC 432 2F2 1	2.700
~ 230...480 V 3-phase 50/60 Hz	1.5 kW	Built-in	TLC 434 2F3 1	3.700
	3 kW	Built-in	TLC 436 2F3 1	6.600
	8 kW	Built-in	TLC 438 2F3 1	10.800

IP 54 degree of protection

~ 230 V single phase 50/60 Hz	0.750 kW	Built-in	TLC 432 5F2 1	8.500
~ 230...480 V 3-phase 50/60 Hz	1.5 kW	Built-in	TLC 434 5F3 1	11.000

(1) For connection cables and accessories, see pages 38 to 41.

(2) To order a TLC 43 servodrive, fill out each reference

TLC 43●●F●		1	●	●	●	●
M1 slot	Without module	1				
M2 slot Position feedback	SinCos Hiperface		2			
	Resolver (4)		3			
M3 slot Encoder simulation	Without encoder simulation			1		
	ESIM3-C Simulation encoder			2		
M4 slot Communication	Without				1	
	RS 485-C				2	
	INTERBUS				3	
	CANopen/DeviceNet				4	
	Profibus-DP				5	
Built-in holding brake controller	Without					1
	With (5)					2

For detailed module specifications, see page 34.

(3) The TLA PH OO operator interface is to be ordered separately, see page 38

(4) Not compatible with SER motors in this catalog.

(5) This function can be integrated only on IP 54 servodrives. The holding brake controller, reference TLA BHO, must be ordered separately for IP 20 servodrives, see page 38.

Dimensions (in mm)

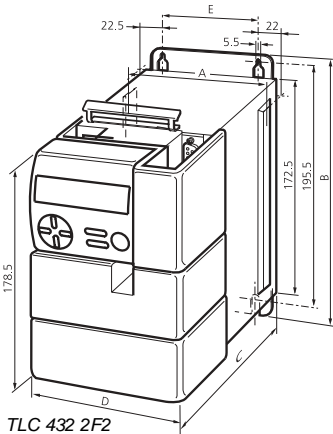

TLC 432 2F2
TLC 434 2F3
(IP 20)

	TLC 432 2F2	TLC 434 2F3
A	108	128
B	212.5	212.5
C	184.5	214.5
D	105.5	125.5
E	63	83

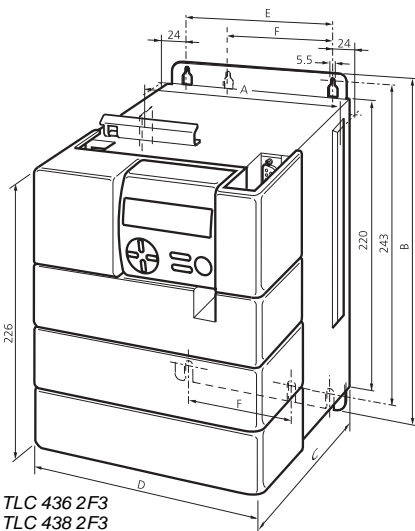

TLC 436 2F3
TLC 438 2F3
(IP 20)

	TLC 436 2F3	TLC 438 2F3
A	178	248
B	260	260
C	244.5	244.5
D	176	246
E	130	200
F	—	120

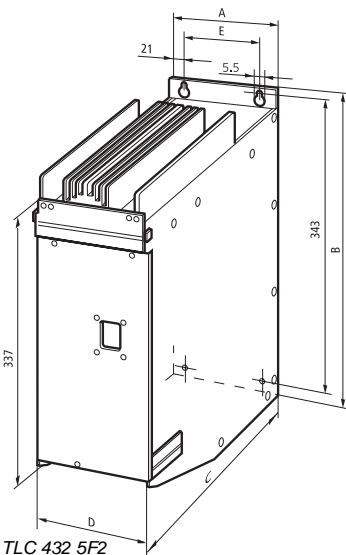

TLC 432 5F2
TLC 434 5F3
(IP 54)

	TLC 432 5F2	TLC 434 5F3
A	127	147
B	360	360
C	245	275
D	127	127
E	80	100

Motion control

Twin Line TLC 53 servodrives

Functions

Twin Line TLC 53 servodrives with built-in position control are equipped with an RS 485 interface or a communication interface via an industrial field bus. They are controlled by a PC or PLC.

Three user modes can be configured for the discrete inputs/outputs:

- Definition of network addresses, transmission speed, field bus profile (RS 485, CANopen/DeviceNet, INTERBUS, Profibus-DP). This authorizes the change and installation of the Twin Line TLC 53 servodrive, without requiring any other tool.
- Discrete reversible inputs/outputs available to the automation system via the field bus or RS 485 interface.
- Editing the internal states of the servodrive.

Position control commands

Each operating mode has a range of parameters specifically for adjustment and activation. For example, it is possible to set different movement speeds for each operating mode.

Switching between operating modes is carried out using a write command on the field bus.

Connection to the field bus enables the Master controller to select all operating modes and to modify all the parameters of these modes. The servodrive immediately carries out the instructions. A complete range of controls is available:

- Point-to-point position control.
- Speed control.
- Electronic gearbox.
- Activation of fast position capture inputs.
- Configuration of electronic cam thresholds and direct activation/deactivation of outputs.
- Adjustment of acceleration and deceleration ramps.
- Change of speed while movement is in progress.
- Reading or writing of the position.
- Triggering of a reference point movement.
- Reading and writing of all parameters.
- Activation and deactivation of outputs.
- Reading inputs.
- Error processing.

Point-to-point position control

In point-to-point position controller mode, a position control command defines a movement from a point A to a point B. The position may be absolute (with reference to the axis reference point) or relative (with reference to the current position).

All changes to the target position or the setpoint speed is processed immediately (even during movement of the axis).

Speed control

In speed control mode, a setpoint speed is attributed to the axis and a movement is launched without a pre-defined target position. The axis moves at this speed until another speed or operating mode is selected. The setpoint speed is modified immediately, even while a movement is in progress.

Position control commands (continued)

Electronic gearbox

In "electronic gearbox" operating mode, movement of the axis is specified by an "encoder" type input.

Three types of signal can be processed:

- A/B Signals.
- Pulse/direction signals.
- Forward/reverse pulse signals.

These signals are processed cyclically, given the adjustable reduction factor, to define a new setpoint position for the axis. The reduction factor can be modified while the axis is moving.

A point-to-point position controller command can also be superimposed on the axis movement in gearbox mode in order to carry out recalibration of the axes.

Reference point

A reference point operation allows a defined axis position to be allocated to a specific mechanical position. This is done either by directly allocating the real position, or by carrying out a reference point movement.

The different types of reference point are:

- With movement to the upper or lower limit switch, or on the reference point cam.
- With or without Z pulse.

Manual movement

All manual movement, controlled by the operator, can be carried out via the discrete inputs/outputs or using the TLA PH OO operator interface or the TLA PS CA commissioning software.

Teach-in

The teach-in consists in recording the current position value in the selected memory space. This operation allows you to record up to 2 x 64 absolute threshold positions for the electronic cam function.

It is activated by the input/output signals. The data can be read, written or copied by the field bus, the TLA PH OO operator interface or the TLA PS CA commissioning software.

Capture inputs

The current position value can be read by 1 or 2 fast inputs or by the index pulse of the position encoder.

It is possible to activate the capture inputs and to read the positions recorded by the field bus, the TLA PH OO operator interface or the TLA PS CA commissioning software.

Acceleration and deceleration ramps

A linear acceleration and deceleration ramp (which may be different) can be defined for the position control of the motors. A bumpless acceleration or deceleration phase is possible thanks to a filtering device which can be activated at any time.

Quick-Stop

The quick-stop function stops the motor as quickly as possible.

It is possible to select a linear braking ramp or a torque ramp (maximum motor current).



TLC 532 2F2
(IP 20)



TLC 538 2F3
(IP 20)



TLC 534 5F3
(IP 54)

Presentation

Twin Line TLC 53 servodrives for servomotors, with built-in position controller and controlled by field bus, are available in the following models:

- IP 20 degree of protection:
 - TLC 532 2F2: 3 A/750 W/230 V single phase,
 - TLC 534 2F3: 3 A/1.5 kW/230...480 V 3-phase,
 - TLC 536 2F3: 6 A/3 kW/230...480 V 3-phase,
 - TLC 538 2F3: 16 A/8 kW/230...480 V 3-phase.

- IP 54 degree of protection:
 - TLC 532 5F2: 3 A/750 W/230 V single phase,
 - TLC 534 5F3: 3 A/1.5 kW/230...480 V 3-phase.

These IP 54 servodrives can be fitted with a built-in holding brake controller, depending on model.

An EMC supply input filter, radiator and fan are integrated as standard on all IP 20 and IP 54 servodrives.

Operating diagram

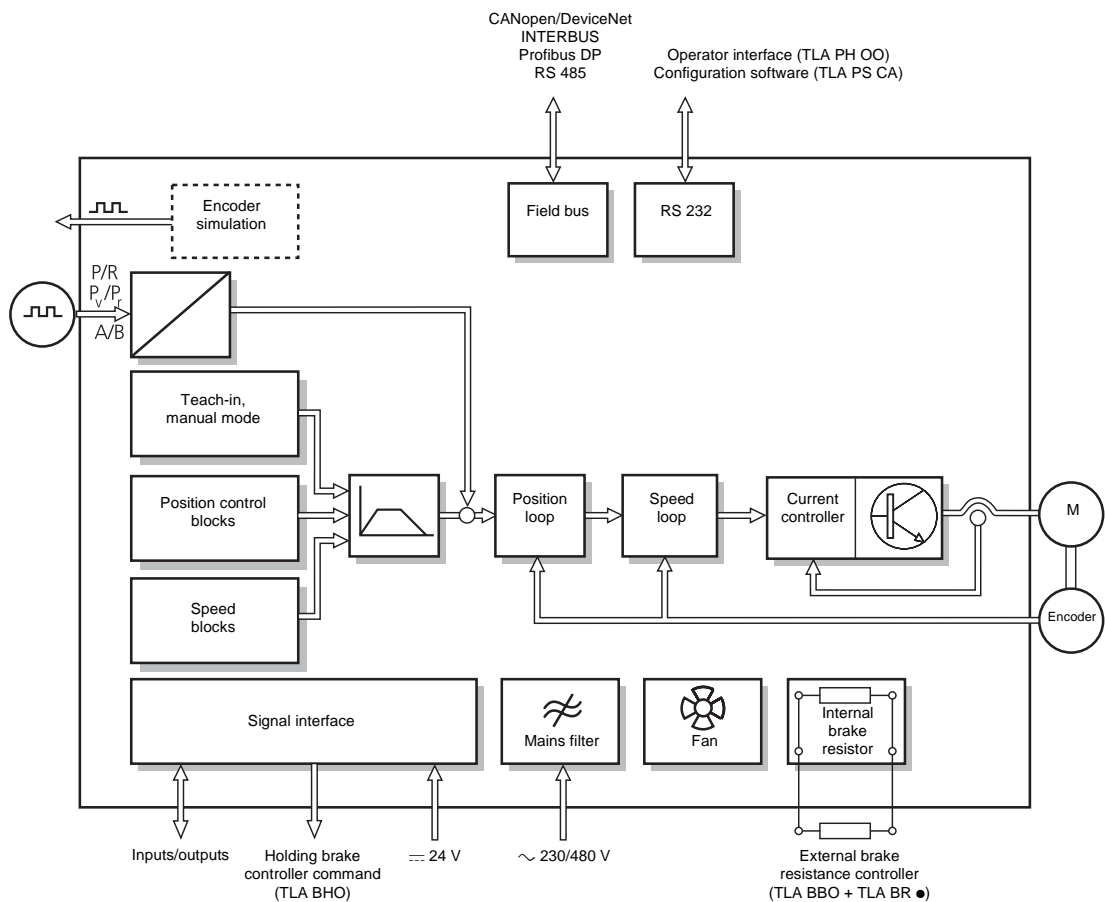

Environment conditions

Ambient temperature (1)	°C	0...+ 50 for IP 20 servodrives, 0...+ 45 for IP 54 servodrives
Storage and transport temperature	°C	- 40...+ 70
Relative humidity		15 to 85 %, non-condensing
Altitude	m	1000
Standards and certifications	Products	UL 508C
	Class of protection	Type 1 according to pr EN 50178
	Overvoltage	Category III according to pr EN 50178
	Pollution	Degree 2 according to pr EN 50178

Electrical characteristics

Type of servodrive		TLC 532 ●F2●●●●●●	TLC 534 ●F3●●●●●●	TLC 536 2F3●●●●●●	TLC 538 2F3●●●●●●	
Degree of protection according to DIN EN 60259		IP 20 (TLC 532 2F2) IP 54 (TLC 532 5F2)	IP 20 (TLC 534 2F3) IP 54 (TLC 534 5F3)	IP 20		
Power supply	Mains voltage	V	~ 1 x 230 V (-20 %)... 240 (+10 %)		~ 1 x 230 (-20 %)...480 (+10 %)	
	Mains frequency	Hz	47...63			
	Consumption	A	6.5	4	7.5	20
	Inrush current	A	< 60			
	aM type external fuse	A	10			25
Motor	Rated power	kW rms	0.75	1.5	3	8
	Continuous current (2)	A rms	3		6	16
	Current peak value over 5 s max.	A rms	6		20	32
	Switching frequency	kHz	8/16			4/8
Motor cable	Cable length	m	≤ 20 m			
	Shielding connection		At each end			
	Cross-section (depending on the length)	mm ²	1.5	1.5...2.5		4
Continuous power bus connection			Maximum of two servodrives of the same power connected in parallel			
Internal brake resistance (3)	Continuous operation	W	30	50	200	80
	Maximum unit brake power	J	50	80	100	130
Supply voltage ≡ 24 V TBTS, DIN 19240	Input voltage	V	20...30 V unprotected against polarity inversions			
	Input ripple	V	< 2 V peak to peak			
	Nominal input current	A	< 2.5			
Inputs (non isolated)	Number of inputs		See page 12			
	Voltage at 1	V	≡ 12...30 (I ≥ 3 mA)			
	Voltage at 0	V	≡ ≤ 5 (I ≤ 0.5 mA)			
	Current	mA	≤ 7 under ≡ 24 V			
	Filtering	ms	0.7...1.5			
Outputs (protected against short-circuits)	Number of outputs		See page 12			
	Voltage	V	≡ ≤ 30			
	Load current	mA	≤ 400			
	Voltage drop at 400 mA	V	≡ ≤ 1			
	Supporting inductive load	mH	150 /11 W			
Analog input	Voltage	V	± 10			
	Input resistance	kΩ	5			
	Resolution	bits	10			

(1) For TLC 532 5F2 and TLC 534 5F3, operation outdoors or in a highly polluted environment is not recommended (clogging up of fan).

(2) rms value in continuous operation at maximum ambient temperature.

(3) For TLC 532 5F2 and TLC 534 5F3, depends on the ambient temperature and ventilation. Consult our regional office.

Motion control

Twin Line TLC 53 servodrives for servomotors



TLC 532 2F2 ●●●●●●
(3)



TLC 538 2F3 ●●●●●●
(3)



TLC 534 5F3 ●●●●●●

References (1)

IP 20 degree of protection

Servodrive supply	Power	EMC supply input filter	Reference (2)	Weight kg
~ 230 V single phase 50/60Hz	0.750 kW	Built-in	TLC 532 2F2 ●●●●●●	2.700
~ 230...480 V 3-phase 50/60 Hz	1.5 kW	Built-in	TLC 534 2F3 ●●●●●●	3.700
	3 kW	Built-in	TLC 536 2F3 ●●●●●●	6.600
	8 kW	Built-in	TLC 538 2F3 ●●●●●●	10.800

IP 54 degree of protection

~ 230 V single phase 50/60Hz	0.750 kW	Built-in	TLC 532 5F2 ●●●●●●	8.500
~ 230...480 V 3-phase 50/60 Hz	1.5 kW	Built-in	TLC 534 5F3 ●●●●●●	11.000

(1) For connection cables and accessories, see pages 38 to 41.

(2) To order a TLC 53 servodrive, fill out each reference

	TLC 53●●F●	●	●	●	●	●
M1 slot Position setpoint	Without module	1				
	RS 422-C Encoder module	2				
	PULSE-C Module	3				
M2 slot Position feedback	SinCos Hiperface	2				
	Resolver (4)	3				
M3 slot Encoder simulation	Without encoder simulation			1		
	ESIM3-C Simulation encoder			2		
M4 slot Communication	Without					1
	RS 485-C					2
	INTERBUS					3
	CANopen/DeviceNet					4
	Profibus-DP					5
Built-in holding brake controller	Without					1
	With (5)					2

For detailed module specifications, see page 34.

(3) The TLA PH 00 operator interface is to be ordered separately, see page 38.

(4) Not compatible with SER motors in this catalog.

(5) This function can be integrated only on IP 54 type servodrives. The holding brake controller, reference TLA BHO, must be ordered separately for IP 20 servodrives, see page 38.

Dimensions in mm

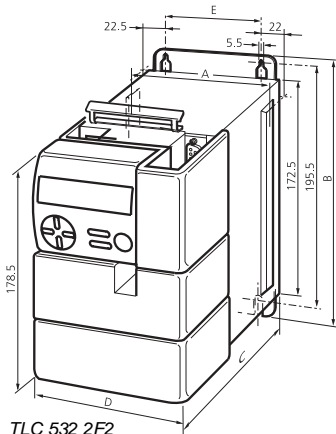

TLC 532 2F2
TLC 534 2F3
(IP 20)

	TLC 532 2F2	TLC 534 2F3
A	108	128
B	212.5	212.5
C	184.5	214.5
D	105.5	125.5
E	63	83

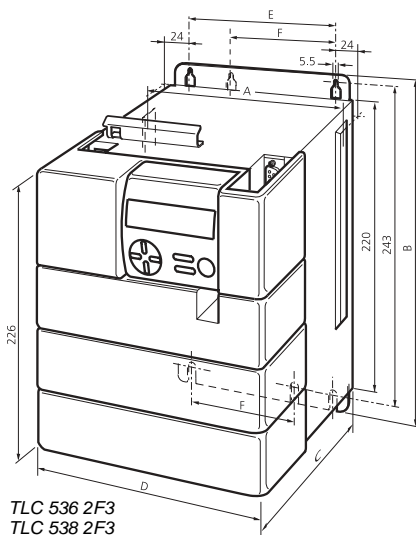

TLC 536 2F3
TLC 538 2F3
(IP 20)

	TLC 536 2F3	TLC 538 2F3
A	178	248
B	260	260
C	244.5	244.5
D	176	246
E	130	200
F	-	120

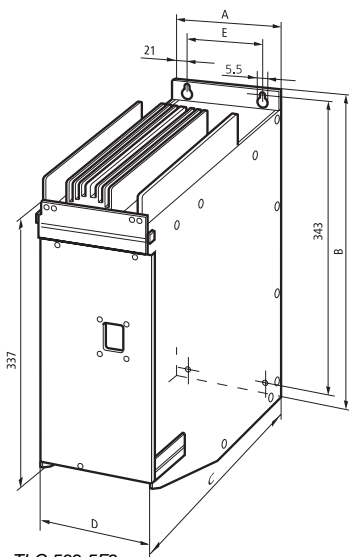

TLC 532 5F2
TLC 534 5F3
(IP 54)

	TLC 532 5F2	TLC 534 5F3
A	127	147
B	360	360
C	245	275
D	127	127
E	80	100

Motion control

Twin Line TLC 63 servodrives

Functions

The Twin Line TLC 63 servodrives are motion controllers which can be programmed in languages compliant with standard IEC 61131-3 for the control of:

- The built-in position controller.
- Local or field bus discrete inputs/outputs.

Applications are developed using the TLA PS PB programming software.

Programmable motion controller

Twin Line TLC 63 servodrives enable simultaneous motion control of a motor and application inputs/outputs. The inputs/outputs are processed cyclically at the same time as axis motion. The motion profiles can be freely defined and their execution synchronized with external events.

The following programming languages are available:

LD : ladder language
FBD : functional block diagram
IL : instruction list
ST : structured text
SFC : sequential function chart, Grafcet language
CFC : continuous function chart

The CANopen/DeviceNet communication module can be used for:

- Communication management between several TLC 63 servodrives.
- Control and command of TLC 43/53 servodrives with CANopen/DeviceNet communication.
- The display and modification of internal parameters using an operator interface.
- The control of discrete or analog remote inputs/outputs on the field bus.

Programmable motion controller (continued)

In addition to common programmable controller functions, a library of motion control functions is available with the TLA PS PB programming software:

- Relative and absolute point-to-point position control.
- Speed control.
- Electronic gearbox.
- Interface with fast position sensor inputs.
- Parametering of electronic cam thresholds and direct activation/deactivation of outputs.
- Adjustment of acceleration and deceleration ramps.
- Change of speed while movement is in progress.
- Reading or writing of the position.
- Triggering of a reference point movement.
- Reading and writing of all parameters.
- Activation and deactivation of outputs.
- Reading inputs.
- Error processing.
- Communication via the CANopen Master field bus.

Point-to-point position control

In point-to-point position controller mode, a position control command defines a movement from a point A to a point B. The position may be absolute (with reference to the axis reference point) or relative (with reference to the current position). All changes to the target position or the setpoint speed is processed immediately (even during movement of the axis).

Speed control

In speed control mode, a setpoint speed is attributed to the axis and a movement is launched without a pre-defined target position. The axis moves at this speed until another speed or operating mode is selected. The setpoint speed is modified immediately, even while a movement is in progress.

Electronic gearbox

In "electronic gearbox" operating mode, movement of the axis is specified by an "encoder" type input.

Three types of signal can be processed:

- A/B Signals.
- Pulse/direction signals.
- Forward/reverse pulse signals.

These signals are processed cyclically, given the adjustable reduction factor, to define a new setpoint position for the axis. The reduction factor can be modified while the axis is moving.

A point-to-point position controller command can also be superimposed on the axis movement in gearbox mode in order to carry out recalibration of the axes.

Programmable motion controller (continued)

Reference point

A reference point operation allows a defined axis position to be allocated to a specific mechanical position. This is done either by directly allocating the real position, or by carrying out a reference point movement.

The different types of reference point are:

- With movement to the upper or lower limit switch, or on the reference point cam.
- With or without Z pulse.

Manual movement

All manual movement, under control of the operator, can be carried out using discrete inputs/outputs or via the TLA PH OO user interface or the TLA PS CA commissioning software compliant with the standard IEC 61131-3 to activate movement of the motor, in a single step or in continuous operation.

Capture inputs

The current position value can be read by 2 fast inputs or by the index pulse of the position encoder.

It is possible to activate the capture inputs and to read the positions recorded by the field bus, the TLA PH OO operator interface or the TLA PS CA commissioning software, of the controller's programming language.

Programmable motion controller (continued)

Acceleration and deceleration ramps

A linear acceleration and deceleration ramp (which may be separate) can be defined for the position control of the motors. A bumpless acceleration or deceleration phase is possible due to a filtering device which can be activated at any time.

Quick-Stop

The quick-stop function enables the motor to be immobilized as quickly as possible. It is possible to select a linear braking ramp or a torque ramp (maximum motor current).



TLC 632 2F2
(IP 20)



TLC 638 2F3
(IP 20)



TLC 634 5F3
(IP 54)

Presentation

Twin Line TLC 63 servodrives, programmable motion controllers for servomotors are available in the following models:

- IP 20 degree of protection:
 - TLC 632 2F2: 3 A/750 W/230 V single phase,
 - TLC 634 2F3: 3 A/1.5 kW/230...480 V 3-phase,
 - TLC 636 2F3: 6 A/3 kW/230...480 V 3-phase,
 - TLC 638 2F3: 16 A/8 kW/230...480 V 3-phase.

- IP 54 degree of protection:
 - TLC 632 5F2: 3 A/750 W/230 V single phase,
 - TLC 634 5F3: 3 A/1.5 kW/230...480 V 3-phase.

These IP 54 servodrives can be fitted with a built-in holding brake controller, depending on model.

An EMC supply input filter, radiator and fan are integrated as standard on all IP 20 and IP 54 servodrives.

Operating diagram

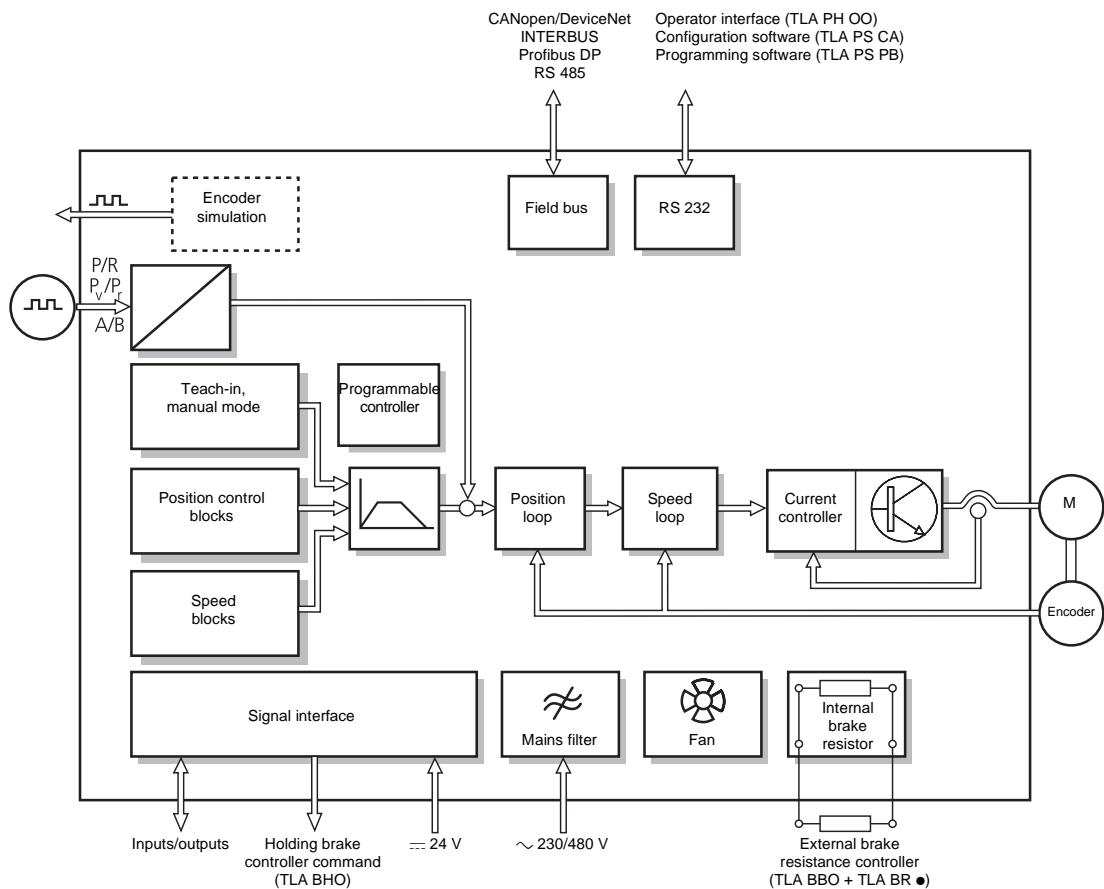

Environment conditions						
Ambient temperature (1)		°C	0...+ 50 for IP 20 servodrives, 0...+ 45 for IP 54 servodrives			
Storage and transport temperature		°C	- 40...+ 70			
Relative humidity			15 to 85 %, non-condensing			
Altitude		m	1000			
Standards and certifications			UL 508 C			
			Class of protection			
			Type 1 according to pr EN 50178			
			Overvoltage			
			Category III according to pr EN 50178			
			Pollution			
			Degree 2 according to pr EN 50178			
Electrical characteristics						
Type of servodrive			TLC 632 ●F2●●●●●●	TLC 634 ●F3●●●●●●	TLC 636 2F3●●●●●●	TLC 638 2F3●●●●●●
Degree of protection according to DIN EN 60259			IP 20 (TLC 632 2F2) IP 54 (TLC 632 5F2)	IP 20 (TLC 634 2F3) IP 54 (TLC 634 5F3)	IP 20	
Power supply	Mains voltage	V	~ 1 x 230 (-20 %)...240 (+10 %)			
	Mains frequency	Hz	47...63			
	Consumption	A	6.5	4	7.5	20
	Inrush current	A	< 60			
	aM type external fuse	A	10			
Motor	Rated power	kW rms	0.75	1.5	3	8
	Continuous current (2)	A rms	3		6	16
	Current peak value over 5 s max.	A rms	6		20	32
	Switching frequency	kHz	8/16		4/8	
Motor cable	Cable length	m	≤ 20			
	Shielding connection		At each end			
	Cross-section (depending on the length)	mm ²	1.5	1.5...2.5		4
Continuous power bus connection			Maximum of two servodrives of the same power connected in parallel			
Internal brake resistance (3)	Continuous operation	W	30	50	200	80
	Maximum unit brake power	J	50	80	100	130
Supply voltage --- 24 V TBTS, DIN 19240	Input voltage	V	20...30 V unprotected against polarity inversions			
	Input ripple	V	< 2 V peak to peak			
	Nominal input current	A	< 2.5			
Inputs (non isolated)	Number of inputs		See page 12			
	Voltage at 1	V	--- 12...30 (I ≥ 3 mA)			
	Voltage at 0	V	--- ≤ 5 (I ≤ 0.5 mA)			
	Current	mA	≤ 7 under --- 24 V			
	Filtering	ms	0.7...1.5			
Outputs (protected against short-circuits)	Number of outputs		See page 12			
	Voltage	V	--- ≤ 30			
	Load current	mA	≤ 400			
	Voltage drop at 400 mA	V	--- ≤ 1			
	Supporting inductive load	mH	150 /11 W			
Analog input	Voltage	V	± 10			
	Input resistance	kΩ	5			
	Resolution	bits	10			
Size of memory for the programmable controller	Memory for application program	Kb	256			
	Memory data (Flash PROM)	Kb	8			
	Memory data saved in case of power outage	bytes	100			
	System data memory	Kb	128			

(6) For TLC 632 5F2 and TLC 634 5F3, operation outdoors or in a highly polluted environment is not recommended (clogging up of fan).

(7) rms value in continuous operation at maximum ambient temperature.

(8) For TLC 632 5F2 and TLC 634 5F3, depends on the ambient temperature and ventilation. Consult our regional office.

Motion control

Twin Line TLC 63 servodrives for servomotors



TLC 632 2F2 ●●●●● (3)



TLC 638 2F3 ●●●●● (3)



TLC 634 5F3 ●●●●●

References (1)

IP 20 degree of protection

Servodrive supply	Power	Power supply EMC input filter	Reference (2)	Weight kg
~ 230 V single phase 50/60 Hz	0.750 kW	Built-in	TLC 632 2F2 ●●●●● ▲	2.700
~ 230...480 V 3-phase 50/60 Hz	1.5 kW	Built-in	TLC 634 2F3 ●●●●● ▲	3.700
	3 kW	Built-in	TLC 637 2F3 ●●●●● ▲	6.600
	8 kW	Built-in	TLC 638 2F3 ●●●●● ▲	10.800

IP 54 degree of protection

~ 230 V single phase 50/60 Hz	0.750 kW	Built-in	TLC 632 5F2 ●●●●● ▲	8.500
~ 230...480 V 3-phase 50/60 Hz	1.5 kW	Built-in	TLC 634 5F3 ●●●●● ▲	11.000

(1) For connection cables and accessories, see pages 38 at 41.

(2) To order a TLC 63 servodrive, fill out each reference

	TLC 63●●F●	●	●	●	●	●
M1 slot	Without module	1				
Position setpoint	RS 422-C Encoder module	2				
	PULSE-C Module	3				
M2 slot	HIFA-C Module		2			
Position feedback	Resolver (4)		3			
M3 slot	Without simulation encoder			1		
Encoder simulation	ESIM3-C Simulation encoder			2		
M4 slot	Without				1	
Communication	RS 485-C				2	
	INTERBUS				3	
	CANopen/DeviceNet				4	
	Profibus-DP				5	
Built-in holding brake controller	Without					1
	With (5)					2

For detailed module specifications, see page 34.

(3) The TLA PH OO operator interface is to be ordered separately, see page 38.

(4) Not compatible with SER motors in this catalog.

(5) This function can be integrated only on IP 54 type servodrives. The holding brake controller, reference TLA BHO, must be ordered separately for IP 20 servodrives, see page 38.

▲ Commercial launch scheduled for 3rd quarter of 2003.

Dimensions (in mm)

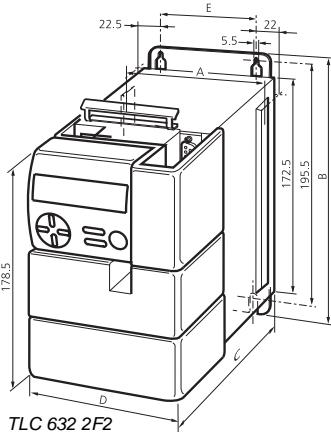

TLC 632 2F2
TLC 634 2F3
(IP 20)

	TLC 632 2F2	TLC 634 2F3
A	108	128
B	212.5	212.5
C	184.5	214.5
D	105.5	125.5
E	63	83

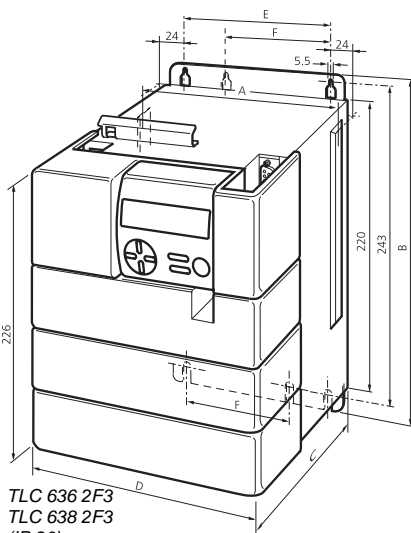

TLC 636 2F3
TLC 638 2F3
(IP 20)

	TLC 636 2F3	TLC 638 2F3
A	178	248
B	260	260
C	244.5	244.5
D	176	246
E	130	200
F	–	120

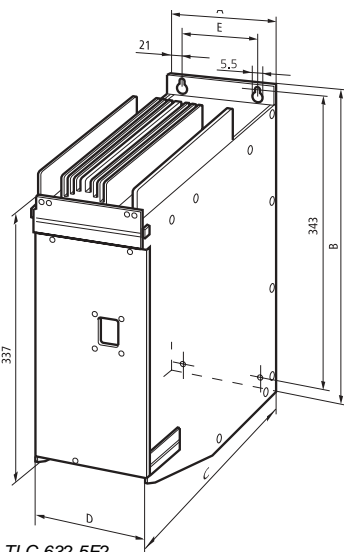

TLC 632 5F2
TLC 634 5F3
(IP 54)

	TLC 632 5F2	TLC 634 5F3
A	127	147
B	360	360
C	245	275
D	127	127
E	80	100

Motion control

Twin Line TLC 43/53/63 servodrives

Interface modules

Presentation

Interface modules for Twin Line TLC 43/53/63 servodrives allow a configuration adapted to the application to be defined using the servodrive. See pages 18, 24 and 32.

RS 422-C module: encoder interface

The RS 422-C module receives signals from an external encoder in the form of A/B signals. It also uses the reference pulse (Z pulse). Characteristic applications: electronic gearbox, external encoder as feedback of the position loop.

PULSE-C Module: pulse interface

The PULSE-C module receives position data in the form of a pulse/direction signal or a forward/reverse pulse signal. The electronic gearbox function is a typical application.

HIFA-C Module: SinCos Hiperface interface

The HIFA-C module receives the position information from a motor fitted with a single turn or multiturn SinCos Hiperface absolute encoder (4096 revolutions). The position of the rotor is detected optically and transmitted to the HIFA-C module in the form of analog and digital position data. The signals are decoded with 14 bit resolution, corresponding to 16 384 pulses/revolution. The built-in digital interface allows initial position information, as well as all the motor parameters of the SinCos encoder memory, to be transmitted to the servodrive.

ESIM3-C Module: encoder simulation

The ESIM3-C module supplies the position data of the motor in the form of incremental signals. These are electrical phase quadrature signals (A/B channels). The transmitted resolution is 1024 pulses/turn. There is no reference pulse. One of the typical uses of this module is to provide a setpoint position to another Twin Line servodrive in electronic gearbox mode.

RS 485-C Communication module

The RS 485-C communication module is an asynchronous interface with four electrically insulated RS 485 wires.

INTERBUS communication module

This module is a communication module for the INTERBUS field bus.

CANopen/DeviceNet communication module

The CANopen bus is a serial sensor/actuator bus. It has a 2-wire connection with the CAN-Low and CAN-High lines.

The user can configure either the CANopen DS-402 profile, or the DeviceNet bus, keeping in mind that the following DeviceNet specifications are excluded:

- DEL diagnostics.
- Type of connector.
- Power supply via the field bus connector.

Profibus-DP communication module

The Profibus-DP bus is a rapid cyclical communication bus. It has a 2-wire RS 485 interface.

Motion control

Twin Line TLC 43/53/63 servodrives

Interface modules

Characteristics

Type of interface module		RS 422-C
For servodrives	Type	TLC 53/63
	Slot	M1
Inputs	Type	RS 422, electrical connection to --- 24 V ground
	Input frequency	≤ 400 kHz
Outputs	External encoder supply	5 V ± 5% 300 mA max., protected against short-circuits and overloads
	Cable length	100 m max.
	Minimum cross-section	0.5 mm ² for power supply 0.25 mm ² for signals
Type of interface module		PULSE-C
For servodrives	Type	TLC 53/63
	Slot	M1
Inputs	Type	RS 422, or 4.5...30 V open collector Electrical connection to --- 24 V ground
	Input resistance	5 kΩ
	Pulse frequency	≤ 200 kHz
	Enable input frequency	≤ 1 kHz
Outputs	Type	Protected against short-circuits with open collector
	Output voltage	≤ 30 V
	Output current	≤ 50 mA
Connection	Maximum length	100 m with RS 422 connection; 10 m with connection to open collector
	Minimum cross-section	0.14 mm ² for signals
Type of interface module		ESIM1-C
For servodrives	Type	TLC 43/53/63
	Slot	M3
A/B signal outputs		RS 422, electrical connection to --- 24 V ground
Type of interface module		RS 485-C
For servodrives	Type	TLC 43/53/63
	Slot	M4
Type		In compliance with the standard RS 485 with electrical insulation and 4 wire interface
Transfer rate		Max. 38.4 Kbit/s
Supply voltage output		+ 12 V (9 V min/15 V max.)
Type of interface module		INTERBUS
For servodrives	Type	TLC 43/53/63
	Slot	M4
Type		In compliance with the INTERBUS specification
Transfer rate		500 Kbit/s
Max. length		400 m between connected components
Type of interface module		CANopen/DeviceNet
For servodrives	Type	TLC 43/53/63
	Slot	M4
Type		Level in compliance with the standard ISO 11898 with electrical insulation
Transfer rate		≤ 1 Mbit/s configurable
Max. length		At 125 Kbit/s: 500 m max. At 500 Kbit/s: 100 m max.
Adapter resistor		120 Ω (to be fitted at each end)
Type of interface module		Profibus-DP
For servodrives	Type	TLC 43/53/63
	Slot	M4
Type		In compliance with the Profibus-DP specification, level RS 485 with electrical insulation
Transfer rate		≤ 12 Mbit/s
Supply voltage output		+ 5 V (10 mA max.) only for the terminal resistor
Length		As per Profibus-DP standard

Motion control

Twin Line TLD/TLC servodrives

Separate components



TLA PH 00

Operator interface

The TLA PH 00 operator interface is designed to control Twin Line TLD/TLC servodrives, and to perform diagnostics for them. It can be plugged into IP 20 Twin Line servodrives.

It features a 3 x 16 character display in 4 languages (English, French, German and Italian). It can be connected to the RS 232 communication interface either directly (IP 20 model), or using the TLA CDC B G cable (ordered separately) of maximum length, 10 meters.

The interface allows you to:

- Consult information concerning the status of the motor, as well as the operating mode and status of the servodrive.
- Check and modify the internal parameters.
- Diagnose errors.
- Control movement in manual mode.
- Copy configuration from one servodrive to another.

Software applications

Configuration and adjustment software

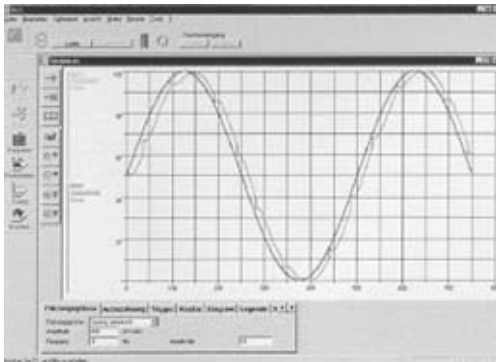

TLA PS CA software screen

The TLA PS CA commissioning tool runs on Windows 98/NT/XP, in conjunction with Twin Line TLD/TLC servodrives.

The configuration and adjustment software enables installation and diagnostics to be carried out rapidly. It is ready for use, without the need for prior configuration.

TLA PS CA software functions:

- Entry and display of servodrive parameters.
- Archiving and reproduction of servodrive parameters.
- Manual position control of motor using a PC.
- Oscilloscope with the recording, display and archiving of movements.
- Offline/online management of position control parameters and data.
- Optimization of control loops.
- Display of mechanical frequency response (F.F.T).
- Diagnostics of operating faults.
- Assistant for facilitating the installation of Twin Line servodrives.

Depending on the type of servodrive, additional functions are available:

- Programming of movement tasks.
- Post-processing of movement lists and movement data.
- Reference point movements.

Programming software

The TLA PS PB programming software runs on Windows 98/NT, in conjunction with Twin Line TLC 63 servodrives and complies with IEC standard 61131-3.

The following programming languages are available:

- LD : ladder language
- FBD : functional block diagram
- IL : instruction list
- ST : structured text
- SFC : sequential function chart, Grafcet language
- CFC : continuous function chart

The CD-ROM reference TLA DOC CD RM contains:

- All useful documentation for the implementation of Twin Line TLD/TLC servodrives and communication networks.
- The description files of the communication interfaces for the SyCon network configuration tool:
 - the .eds files for the CANopen network
 - the .gsd files for the Profibus-DP network.

Motion control

Twin Line TLD/TLC servodrives

Separate components



TLA BBO

Brake resistance controller

The TLA BBO brake resistance controller for Twin Line TLD/TLC servodrives switches an external brake resistance onto the intermediate circuit of the servodrive, when this circuit reaches a high voltage level.

It is possible to connect the maximum of 2 Twin Line servodrives of the same power rating to the controller. The intermediate circuits of both units are connected in parallel. The controller is connected to the TLD/TLC servodrive using TLA CB AA A ●●● cables.



TLA BR●

Brake resistor

The TLA BR ● brake resistor is a high-performance resistor equipped with a shielded cable of 0.75 m in length for connecting to the brake resistor controller TLA BBO.

The brake resistor is designed with IP 54 degree of protection. An attachment bracket is delivered with the product.

The brake resistor is available in two ohm values: 72 Ω or 150 Ω , and for a continuous power of 100 W or 200 W. The surface temperature must not exceed 250 °C.



TLA BHO

Holding brake controller

The TLA BHO holding brake controller amplifies the brake control signal transmitted by the Twin Line TLC/TLD servodrives, so that the brake is activated rapidly and produces as little heat as possible.

Depending on the type of motor used, it is possible to select whether the operation is carried out with or without a reduction in the brake voltage, using the rotary switch located on the servodrive.

Twin Line TLC servodrives with IP 54 degree of protection can be fitted to this controller, see pages 18, 24 and 32.

Motion control

Twin Line TLD/TLC servodrives

Separate components



TLA PH 00

References

Operator interface

Description	Use	Length	Reference	Weight kg
Operator interface	Can be directly connected to TLD/TLC (IP 20) servodrives Can be connected by cable to TLC (IP 54) servodrives	–	TLA PH 00	–
Connection cables (fitted with 2 9-pin SUB-D type connectors)	For remote connection of the TLA PH 00 operator interface	1.5 m	TLA CDC B G 015	–
		3 m	TLA CDC B G 030	–
		5 m	TLA CDC B G 050	–
		10 m	TLA CDC B G 100	–

Software tools

Description	Use	Operating system	Reference	Weight kg
Commissioning software	For all TLD/TLC servodrives	Windows 98/NT/XP	TLA PS CA	–
Programming software	For the TLC 63 servodrive	Windows 98/NT/XP	TLA PS PB	–

Description	Use	Length	Reference	Weight kg
Connection cables (fitted with 2 9-pin SUB-D type connectors)	For connecting a TLD/TLC servodrive to a PC	5 m	TLA CD P B G 050	–
		10 m	TLA CD P B G 100	–

Controller and brake resistors

Description	Use	Resistance value/Power	Reference	Weight kg
Brake resistance controller	For TLD/TLC servodrive	–	TLA BBO	–
Brake resistors (come equipped with a 0.75 m long cable and attachment bracket)	For the controller TLA BBO. The TLA BBO controller is connected using the cable supplied.	72 Ω/100 W	TLA BR A	–
		150 Ω/100 W	TLA BR B	–
		72 Ω/200 W	TLA BR C	–
		150 Ω/200 W	TLA BR D	–

Description	Use	Cable cross-section	Length	Reference	Weight kg
Connection cables (free ends)	Connection between the TLD/TLC servodrive and the TLA BBO controller with the resistor TLA BR A/B	2 x 2.5 mm ²	0.5 m	TLA CB AA A 005	–
			1.5 m	TLA CB AA A 015	–
			3 m	TLA CB AA A 030	–
			5 m	TLA CB AA A 050	–
	Connection between the TLD/TLC servodrive and the TLA BBO controller with the resistor TLA BR C/D	2 x 4 mm ²	0.5 m	TLA CB AA B 005	–
			1.5 m	TLA CB AA B 015	–
			3 m	TLA CB AA B 030	–
			5 m	TLA CB AA B 050	–

Holding brake controller

Description	Use	Reference	Weight kg
Holding brake controller	For TLD/TLC (IP 20) servodrives	TLA BHO	–



TLA BBO



TLA BR A/B



TLA BHO

Motion control

Twin Line TLD/TLC servodrives

Separate components

References (continued)				
Separate components				
Description	For servodrive	Type	Reference	Weight kg
Line terminator for CANopen bus	TLC 43/53/63	Female, 9-pin	TLA T A	–
		Male, 9-pin	TLA T B	–
All connectors	TLD 13 for slots M1 and M2	SUB-D	TLA T F	–
		TLD/TLC for slots M1, M2, M3, M4 and RS 232 interface	SUB-D	TLA T D
Connection shielding accessory	TLD/TLC	–	TLA T E	–
Separate components for TLC (IP 54) servodrives				
Cable support (inside the servodrive casing)	TLC (IP 54)	–	TLA T C	–
Cable seal	TLC (IP 54)	–	TLA T K	–
Fan	TLC (IP 54)	–	TLA M S	–
Twin Line CD-ROM				
Description	Content	Reference	Weight kg	
Twin Line CD-ROM	<ul style="list-style-type: none"> ■ All useful documentation for the implementation of Twin Line TLD/TLC servodrives and communication networks. ■ The description files of the communication interfaces for the SyCon network configuration tool: <ul style="list-style-type: none"> □ the .eds files for the CANopen network □ the .gsd files for the Profibus-DP network. 	TLA DOC CD RM	–	

Motion control

Twin Line TLD/TLC servodrives

Separate components

References (continued)							
Connection cables for interface modules							
Description	For servodrive Use		Composition	Length	Reference	Weight kg	
Connection cables for RS 422-C encoder module	TLD 13, TLC 53/63	Connecting the servodrive to an incremental encoder	Free wire ends	0.5 m	TLA CD C A C 005	–	
				1.5 m	TLA CD C A C 015	–	
				3 m	TLA CD C A C 030	–	
				5 m	TLA CD C A C 050	–	
Connection cables for PULSE-C module	TLD 13, TLC 53/63	Connecting the servodrive to an external pulse control	Fitted with 2 x 15 pin SUB-D type connectors	0.5 m	TLA CD C B B 005	–	
				1.5 m	TLA CD C B B 015	–	
				3 m	TLA CD C B B 030	–	
				5 m	TLA CD C B B 050	–	
				Free wire ends	0.5 m	TLA CD C A B 005	–
					1.5 m	TLA CD C A B 015	–
					3 m	TLA CD C A B 030	–
					5 m	TLA CD C A B 050	–
Connection cables for modules RS 485-C	TLC 43/53/63	Connecting the servodrive to an RS 485 interface	Free wire ends	0.5 m	TLA CD C A D 005	–	
				1.5 m	TLA CD C A D 015	–	
				3 m	TLA CD C A D 030	–	
				5 m	TLA CD C A D 050	–	
Connection cables for CANopen/DeviceNet module	TLC 43/53/63	Connecting the servodrive to the bus	Fitted with 2 x 9 pin SUB-D type connectors	0.5 m	TLA CD C A B 005	–	
				1.5 m	TLA CD C A B 015	–	
				3 m	TLA CD C A B 030	–	
				5 m	TLA CD C A B 050	–	
Connection cables for InterBus modules	TLC 43/53/63	Connecting the servodrive to the bus	Fitted with 2 x 15 pin SUB-D type connectors	0.5 m	TLA CD C B F 005	–	
				5 m	TLA CD C B F 050	–	
Connection cables for ESIM1-C/2-C or SSI-C modules	TLD 13	Incremental or absolute SSI encoder emulation	Free wire ends	0.5 m	TLA CD C A E 005	–	
				1.5 m	TLA CD C A E 015	–	
				3 m	TLA CD C A E 030	–	
				5 m	TLA CD C A E 050	–	
Connection cables for connecting ESIM1-C/2-C modules to an RS 422 interface and for connecting an ESIM3-C module	TLD 13, TLC 43/53/63	Connecting a TLD 13 servodrive fitted with a ESIM1-C/2-C module to the RS 422 interface of another TLD 13 servodrive. Connecting a TLC 43/53/63 servodrive fitted with a ESIM3-C module in "electronic gearbox" operating mode	Fitted with 2 x 15 pin SUB-D type connectors	0.5 m	TLA CD C B H 005	–	
				1.5 m	TLA CD C B H 015	–	
				3 m	TLA CD C B H 030	–	
				5 m	TLA CD C B H 050	–	
Servomotor connection cables	TLD 13, TLC 43/53/63	–	–	–	See page 63	–	

References (continued)

Connection cables for Premium platforms

Description	Use	Composition	Length	Reference	Weight kg
Connection cables for Premium platforms	Connecting the TLD 13 servodrive fitted with the ESIM1-C/2-C module to the TSX CAY module of the Premium PLC (incremental encoder interface)	Fitted with 2 x 15-pin SUB-D type connectors	2 m	TSX CXP 273	–
			6 m	TSX CXP 673	–
	Connecting the TLD 13 servodrive fitted with the SSI-C module to the TSX CAY module of the Premium PLC (SSI encoder interface)	Fitted with 2 x 15-pin SUB-D type connectors	2 m	TSX CXP 253	–
			6 m	TSX CXP 653	–

Connecting the Twin Line TLD 13 servodrive to the TSX CAY Premium module

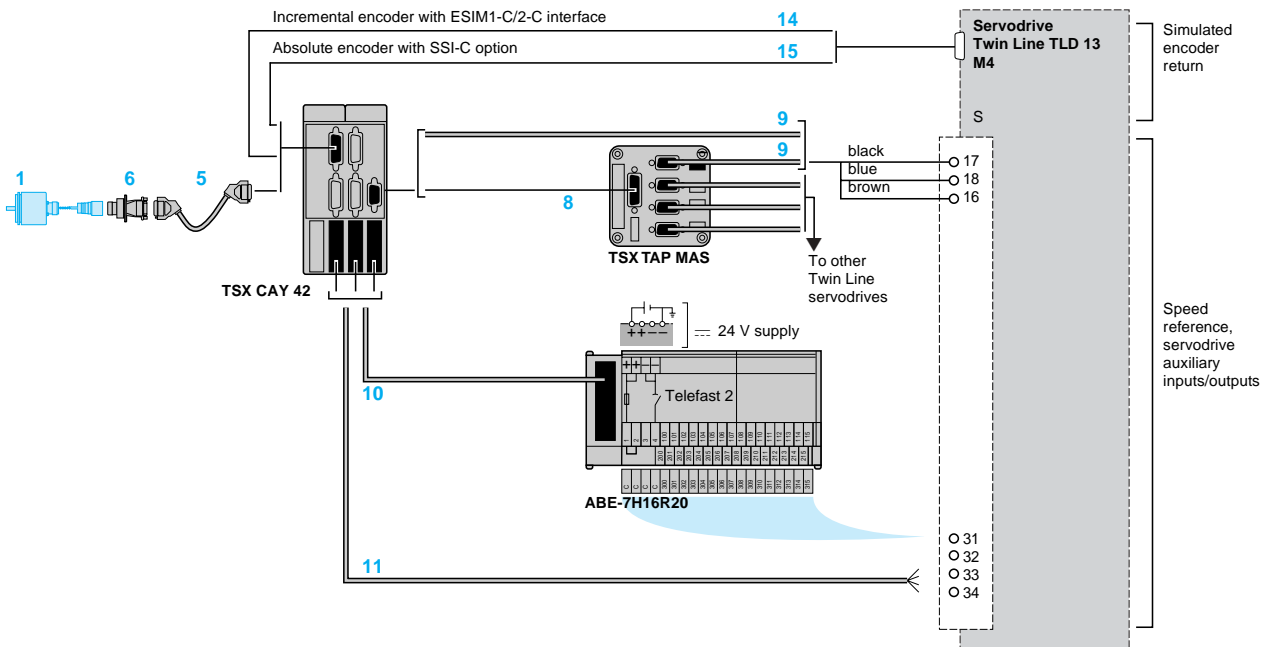

- 1 Incremental or absolute encoder
- 5 TSX CCP S15 cable fitted with connectors (encoder return)
- 6 TSX TAP S15 05 connector
- 8 TSX CXP 213/613 cable fitted with connectors
- 9 TSX CDP 611 rolled ribbon cable fitted with connectors
- 10 TSX CDP 3 cable fitted with connectors
- 11 TSX CDP 01 rolled ribbon cable fitted with connectors
- 14 TSX CXP 273/673 cable fitted with connectors (simulated incremental encoder return)
- 15 TSX CXP 253/653 cable fitted with connectors (simulated absolute SSI encoder return)

Nota : for the components referenced 1 to 11, consult our "Lexium Motion Control" catalog No. AUTCD21124207ENG or our "Premium Automation Device Platform" catalog No. AUTC201496125ENG.



Presentation

SER brushless motors are equipped with Neodymium Iron Borium (NdFeB) magnets and provide a high power density within a confined space, as well as a dynamic velocity range that meets all machine requirements. Thermal protection is provided by an integral probe in the motor. These motors support high overloads without risk of demagnetization. SER motors are certified "Recognized" (UR) by the Underwriters Laboratories. They are compliant with standard UL1004 and with European directives (marking CE).

Depending on the model, SER brushless motors can be equipped with a shaft seal (IP 41 or IP 56), a holding brake and/or a gearbox.

Twin Line TLD/TLC servodrives, associated with SER motors, deliver a sinusoidal wave allowing perfect rotation, even at low speed.

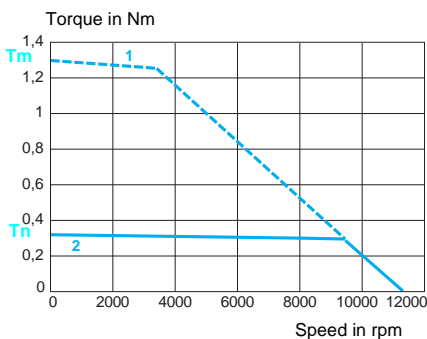

Speed/torque characteristics

SER motors show torque/speed profiles similar to the example opposite with:

- 1 Peak torque at 230 V single phase or 400 V 3-phase (depending on the servodrive model).
- 2 Continuous torque at 230 V single phase or 400 V 3-phase (depending on the servodrive model).

where:

12,000 (in rpm) corresponds to the motor's maximum mechanical speed.

T_m (in Nm) represents the peak stall torque value.

T_n (in Nm) represents the continuous stall torque value.

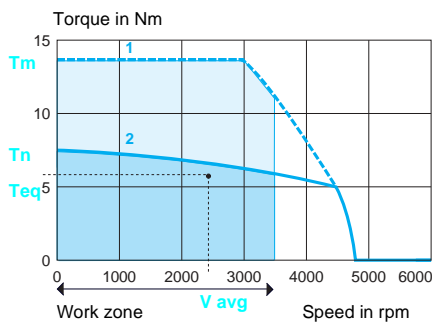

Principle for determining the size of the motor according to the application

Torque/speed curves can be used to determine optimum motor size. For example, for a supply voltage of 400 V, 3-phase, the graphs used are graphs 1 and 2. The diagram of speeds and torques according to the motor cycle must also be defined (consult our catalog "Lexium Motion Control" no. AUTCD21124207EN).

- Locate the work zone of the application in terms of speed.
- Verify, using the motor cycle diagram, that the torques required by the application during the different cycle phases are located within the area bounded by graph 1 in the work zone.
- Calculate the average speed S_{avg} and the equivalent thermal torque T_{eq} .
- The point defined by S_{avg} and T_{eq} must be within the area bounded by graph 2 in the work zone.

The "Schneider Motion Sizer" motor sizing utility, will help the designer calculate the size of motors using application data.

Functions

SER brushless motors have been developed to meet to the following requirements:

- Functional characteristics, robustness, safety, in compliance with IEC 34-1.
- Ambient operating temperature: - 25...+40 °C in compliance with DIN 50019R14.
- Relative humidity: ≤ 75 % yearly average/95 % for 30 days without condensation.
- Storage and transport temperature: - 25...+ 70 °C.
- Winding insulation class: F (threshold temperature for windings 155 °C) in compliance with VDE 0530.
- Supply and sensor connections using angled connectors rotatable through 310 °.
- Thermal protection by built-in PTC thermistor probe, controlled by the Twin Line servodrive.
- Out-of-round, concentricity and perpendicularity between flange and shaft as per DIN 42955, class N.
- Flange compliant with standard DIN 42948.
- Permitted mounting positions: no mounting restriction for IMB5 - IMV1 and IMV3 as per DIN 42950.
- Polyester resin based paint: opaque black RAL 9005.

Functions

- Degree of protection of the motor casing: IP 56 as per IEC 529.
- Degree of protection of the shaft end: IP 41 or IP 56 in accordance with IEC 529.
- Degree of protection of the gearbox (depending on model): IP 54 as per IEC 529.
- Integrated sensor, single turn or multiturn absolute encoder (4096 revolutions) SinCos Hiperface high resolution interface.
- Standard sized shaft end (as per DIN 42948):
 - motor without gearbox: smooth shaft end (1),
 - motor equipped with gearbox: shaft end with key.

Holding brake (depending on model)

The integral brake fitted on SER motors (depending on the model) is a failsafe electro-magnetic holding brake.

⚠ The brake torque decreases when the motor temperature exceeds 80°C. Unless the maximum temperature of the motor is known and is less than 80°C according to the loads applied, do not expose the brake to more than 50% of its continuous torque value.

⚠ Do not use the holding brake as a dynamic brake for deceleration purposes.

Built-in encoder

The motor is fitted with an absolute encoder which, depending on the model, can be:

- A single turn or multiturn high-resolution absolute encoder, (4096 revolutions) with an angular shaft position precise to less than ± 45 arc seconds.

This performs the following functions:

- Gives the angular position of the rotor in such a way that flows can be synchronized.
- Measures the motor speed via the associated Twin Line servodrive. This information is used by the speed controller of the Twin Line servodrive.
- May measure position information for the position controller of the Twin Line servodrive.
- Measures and, where necessary, transmits position information in incremental or absolute format, for the position return of a motion control module (Twin Line servodrive fitted with an ESIM module).

(1) For shaft end with key, consult our Regional Sales Office.

Motion control

SER brushless motors for Twin Line servodrives

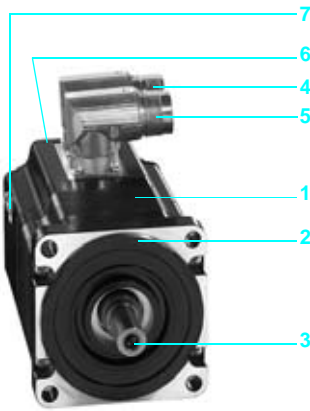

Description

SER brushless motors with a 3-phase stator and an 8-pole rotor with Neodymium Iron Borium magnets (NdFeB) are comprised of:

- 1 Housing with a square cross-section, protected by black opaque polyester resin paint RAL 9005.
- 2 Axial flange with 4 fixing points in compliance with standard DIN 42948.
- 3 A smooth shaft end compliant with the standard DIN 42948 (1).
- 4 A dust and damp-proof male screw connector for connecting the power cable. The output of this connector is continuously rotatable through an arc of 310°.
- 5 A dust and damp-proof male screw connector for connecting the encoder. The output of this connector is continuously rotatable through an arc of 310°.
- 6 A manufacturer's data plate located on the side opposite the shaft end.
- 7 A ground terminal.

Connector to be ordered separately, for connecting to Twin Line TLD/TLC servodrives. See pages 63.

Schneider Electric has taken great care to achieve the most appropriate match between SER motors and Twin Line servodrives. This compatibility is only guaranteed when cables sold by Schneider Electric are used (see pages 63).

(1) For shaft end with key, consult our Regional Sales Office.

Characteristics of SER 364/366 motors

Type of SER motor		364 3L 3S	364 3L 5S	364 3L 7S	366 3L 3S	366 3L 5S	366 3L 7S		
Torque (model without gearbox)	Associated with the Twin Line servodrive	TL●●32	TL●●32	TL●●32	TL●●32	TL●●32	TL●●32		
	Continuous stall	Tn	Nm	0.32	0.32	0.32	0.54	0.54	0.54
	Peak stall	Tm	Nm	0.82	1.1	1.3	1.15	1.6	2.15
Current	Permanent	A rms	2.3	1.45	1.15	2.75	1.8	1.25	
	Maximum	A rms	6		5.7	6			
Demagnetization current	A	11.5	7.3	5.7	13.5	8.5	6		
Maximum mechanical speed	rpm	12 000							
Constants (at 25°C)	Torque	Nm/A rms	0.14	0.22	0.28	0.19	0.3	0.43	
	Back emf	V rms s/rad	0.087	0.13	0.17	0.11	0.17	0.25	
Rotor	Number of poles	6							
	Inertia without brake	Jm	gm ²	0.01			0.018		
	Inertia with brake	Jm	gm ²	0.017			0.025		
Stator (at 25 °C)	Resistance (phase/phase)	Ω	4.7	11.1	18.9	3.7	9.1	17.4	
	Inductance (phase/phase)	mH	9.2	21.8	37.9	7.9	21	37.5	
	Electrical time constant	ms	1.9	1.9	2	2.1	2.3	2.1	
Holding brake (depending on model)	See page 64								
Gearbox (depending on model)	See page 66								

Speed/torque graphs

SER Motors 364 3L 3S

SER Motors 364 3L 5S

SER Motors 364 3L 7S

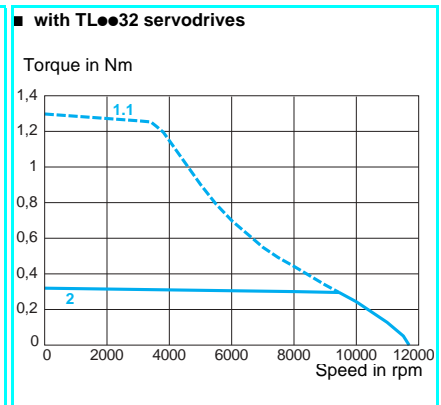
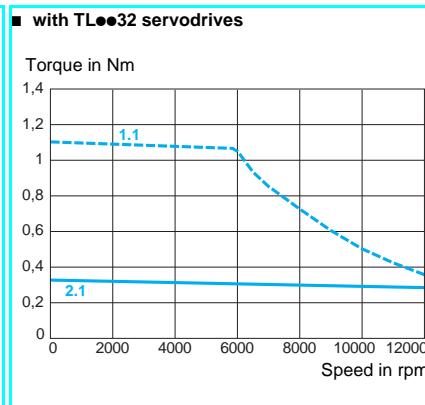
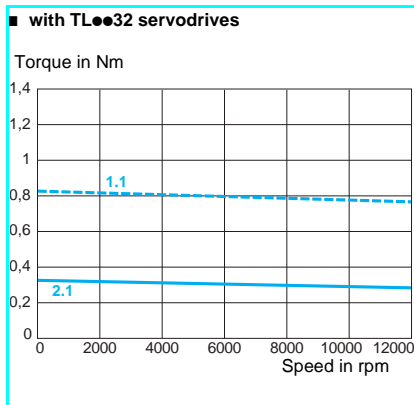

SER 366 3L 3S Motors

SER 366 3L 5S Motors

SER 366 3L 7S Motors

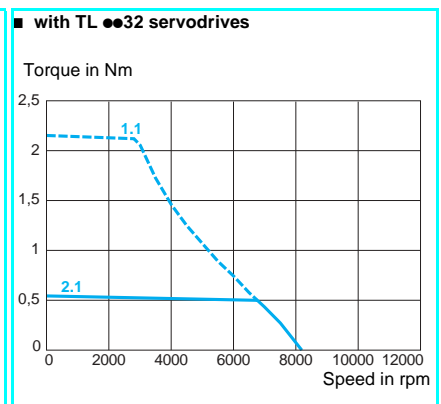
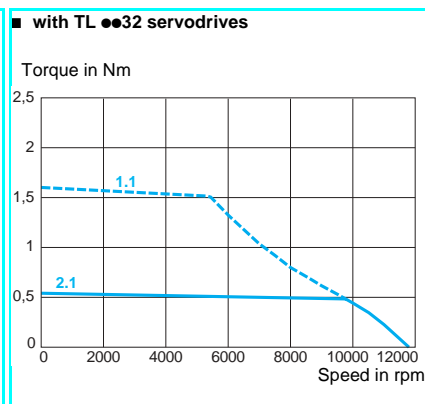
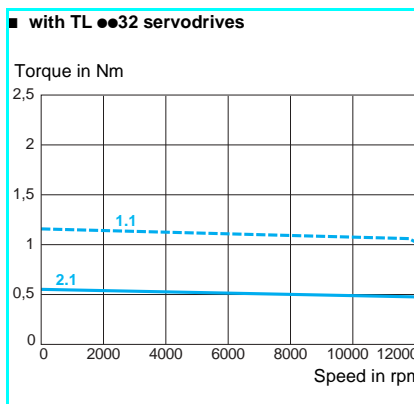

1.1 Peak torque at 230 V, single phase

2.1 Continuous torque at 230 V, single phase

Characteristics of SER 368/36A motors

Types of SER motor			368 3L 3S	368 3L 5S	368 3L 7S	36A 3L 3S	36A 3L 5S	36A 3L 7S
Torque (model without servodrive gearbox)	Associated with the Twin Line		TL●●32	TL●●32	TL●●32	TL●●32	TL●●32	TL●●32
	Continuous stall	T_n	Nm	0.74	0.75	0.75	0.76	0.9
	Peak stall	T_m	Nm	1.5	1.92	3	1.5	2.1
Current	Permanent		A rms	3	2.1	1.15	3	2.3
	Maximum		A rms	6				1.2
Demagnetization current			A	15.3	10.5	6	17.5	11.5
Maximum mechanical speed			rpm	12 000				
Constants (at 25°C)	Torque		Nm/A rms	0.25	0.35	0.65	0.25	0.39
	Back emf		V rms s/rad	0.14	0.21	0.37	0.15	0.23
Rotor	Number of poles			6				
	Inertia without brake	J_m	gm²	0.026			0.028	
	Inertia with brake	J_m	gm²	0.033				
Stator (at 25 °C)	Resistance (phase/phase)		Ω	3.4	7.3	23.7	2.7	6.1
	Inductance (phase/phase)		mH	7.6	15.9	53	6	14
	Electrical time constant		ms	2.2	2.1	2.2	2.2	2.3
Holding brake (depending on model)				See page 64				
Gearbox (depending on model)				See page 66				

Speed/torque graphs

SER 368 3L 3S Motors

SER 368 3L 5S Motors

SER 368 3L 7S Motors

■ with TL●●32 servodrives

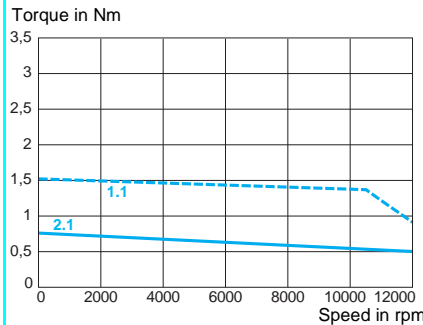

■ with TL●●32 servodrives

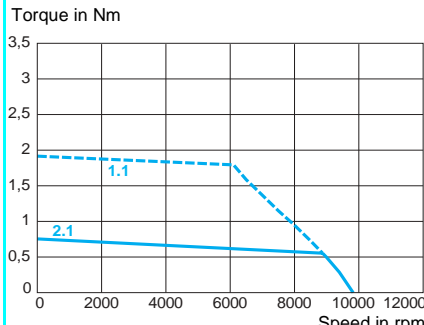

■ with TL●●32 servodrives

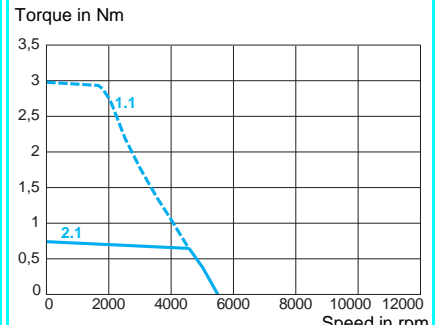

SER 36A 3L 3S Motors

SER 36A 3L 5S Motors

SER 36A 3L 7S Motors

■ with TL●●32 servodrives

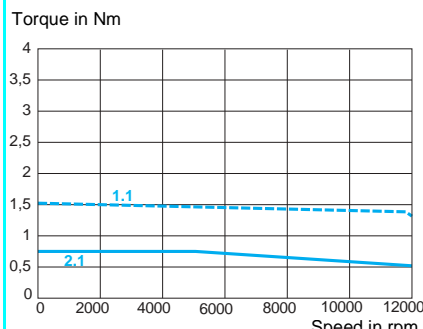

■ with TL●●32 servodrives

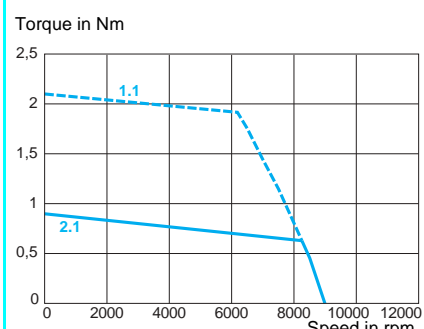

■ with TL●●32 servodrives

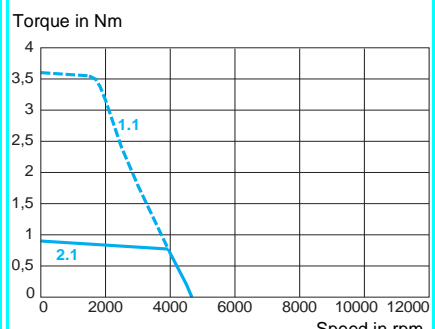

1.1 Peak torque at 230 V, single phase
2.1 Continuous torque at 230 V, single phase

Characteristics of SER 39A motors

Type of motor		SER 39A 4L 3S		SER 39A 4L 7S	
			TL●●32	TL●●32	TL●●34
Torque (model without gearbox)	Associated with the Twin Line servodrive				
	Continuous stall	Tn	Nm	1.1	
	Peak stall	Tm	Nm	2.4	4
Current	Permanent		A rms	2.6	1.3
	Maximum		A rms	6	
Demagnetization current			A	12	6
Maximum mechanical speed			rpm	6000	
Constants (at 25°C)	Torque		Nm/A rms	0.42	0.85
	Back emf		V rms s/rad	0.26	0.48
Rotor	Number of poles			8	
	Inertia without brake	Jm	gm ²	0.085	
	Inertia with brake	Jm	gm ²	0.105	
Stator (at 25 °C)	Resistance (phase/phase)		Ω	3.7	13
	Inductance (phase/phase)		mH	13.6	47.9
	Electrical time constant		ms	3.7	
Holding brake (depending on model)				See page 64	
Gearbox (depending on model)				See page 66	

Speed/torque graphs

SER Motors 39 A 4L 3S

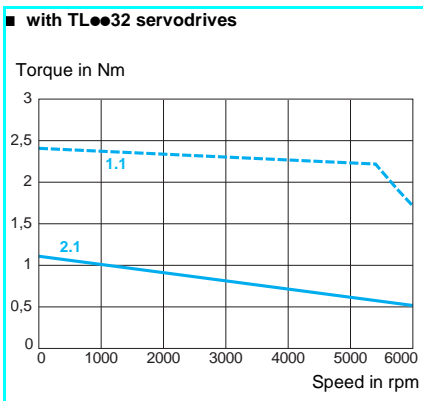

SER 39A 4L 7S Motors

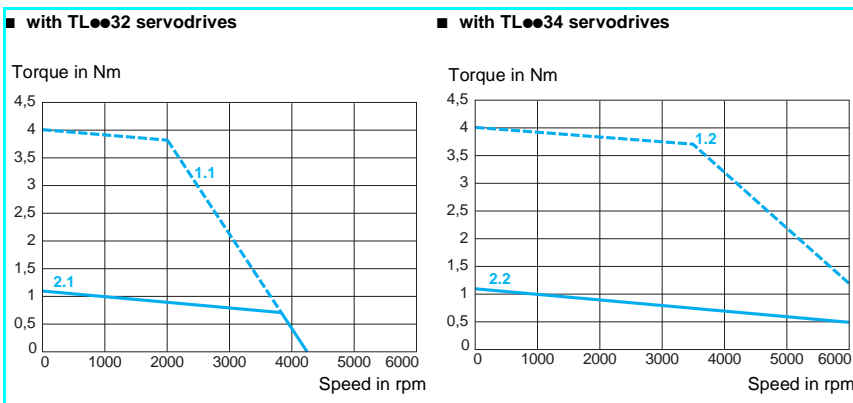

- 1.1 Peak torque at 230 V, single phase
- 1.2 Peak torque at 400 V, 3-phase
- 2.1 Continuous torque at 230 V, single phase
- 2.2 Continuous torque at 400 V 3-phase

Characteristics of SER 39B motors

Type of motor		SER 39B 4L 3S			SER 39B 4L7S	
		TL●●32	TL●●34	TL●●36	TL●●32	TL●●34
Torque (model without gearbox)	Associated with the Twin Line servodrive					
	Continuous stall	T_n	Nm	2.2		
	Peak stall	T_m	Nm	4.2	4.2	7.8
Current	Permanent		A rms	3		1.7
	Maximum		A rms	6	12	6
Demagnetization current			A	12		6
Maximum mechanical speed			rpm	6000		
Constants (at 25°C)	Torque		Nm/A rms	0.73		1.29
	Back emf		V rms s/rad	0.45		0.79
Rotor	Number of poles			8		
	Inertia without brake	J_m	gm ²	0.16		
	Inertia with brake	J_m	gm ²	0.18		
Stator (at 25 °C)	Resistance (phase/phase)		Ω	5.4		13.7
	Inductance (phase/phase)		mH	20.3		60.7
	Electrical time constant		ms	3.7		4.4
Holding brake (depending on model)				See page 64		
Gearbox (depending on model)				See page 66		

Speed/torque graphs

SER Motors 39B 4L 3S

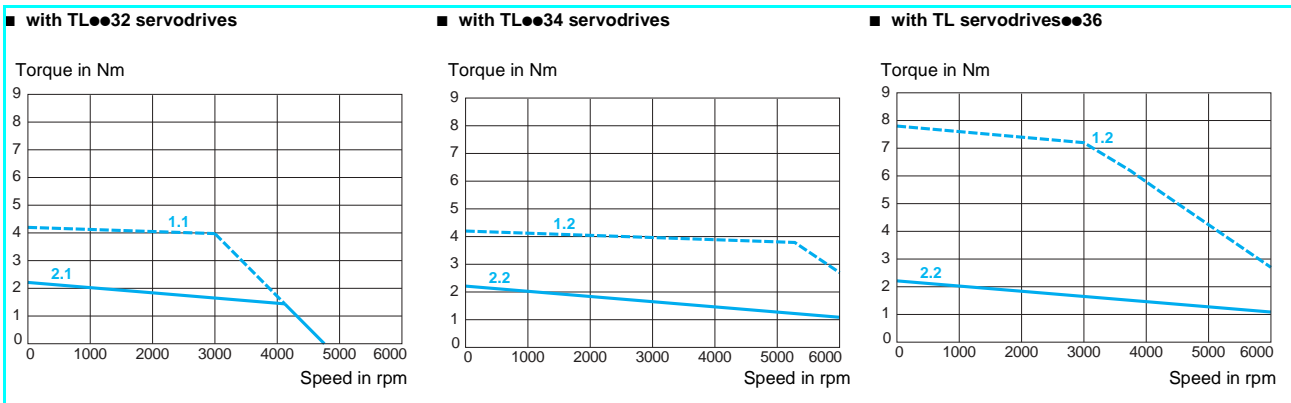

SER Motors 39B 4L 7S

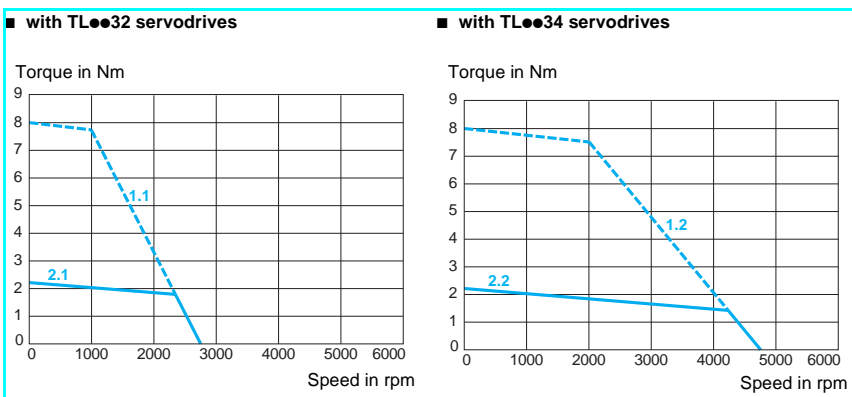

- 1.1 Peak torque at 230 V, single phase
- 1.2 Peak torque at 400 V, 3-phase
- 2.1 Continuous torque at 230 V, single phase
- 2.2 Continuous torque at 400 V 3-phase

Characteristics of SER 39C motors

Type of motor			SER 39C 4L 3S			SER 39C 4L 5S		
Torque (model without gearbox)			TL●●32	TL●●34	TL●●36	TL●●32	TL●●34	TL●●36
Associated with the Twin Line servodrive	Continuous stall	T _n	Nm	2.35		2.9		
	Peak stall	T _m	Nm	4.8	4.8	11.5	6.8	11.5
Permanent			A rms	3		3.7	2.5	
	Maximum		A rms	6		18	6	
Demagnetization current			A	18		12		
Maximum mechanical speed			rpm	6000				
Constants (at 25 °C)	Torque		Nm/A rms	0.78		1.16		
	Back emf		V rms s/rad	0.47		0.69		
Rotor	Number of poles			8				
	Inertia without brake	J _m	gm ²	0.24				
	Inertia with brake	J _m	gm ²	0.26				
Stator (at 25 °C)	Resistance (phase/phase)		Ω	3.3		7.5		
	Inductance (phase/phase)		mH	14.1		30.3		
	Electrical time constant		ms	4.3		4		
Holding brake (depending on model)				See page 64				
Gearbox (depending on model)				See page 66				

Speed/torque graphs

SER Motors 39C 4L 3S

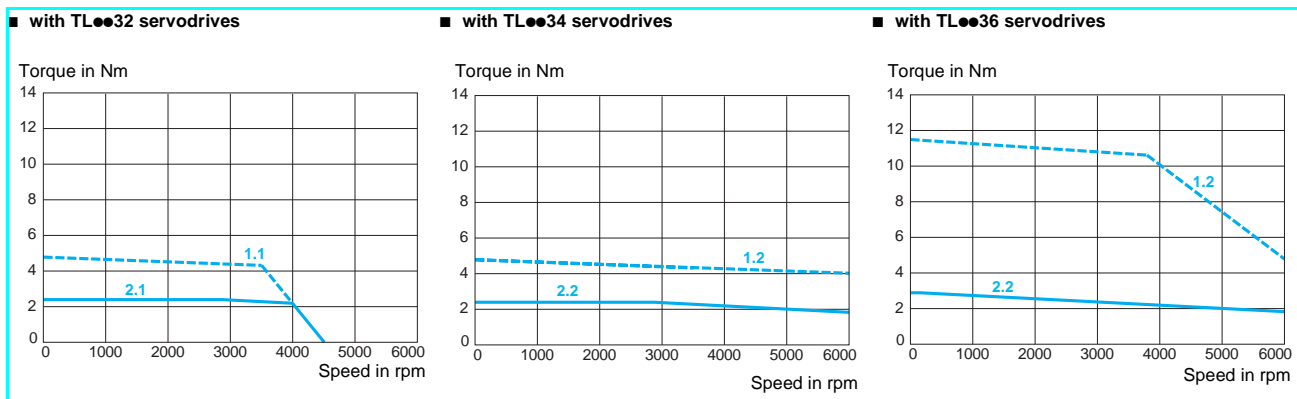

SER Motors 39C 4L 5S

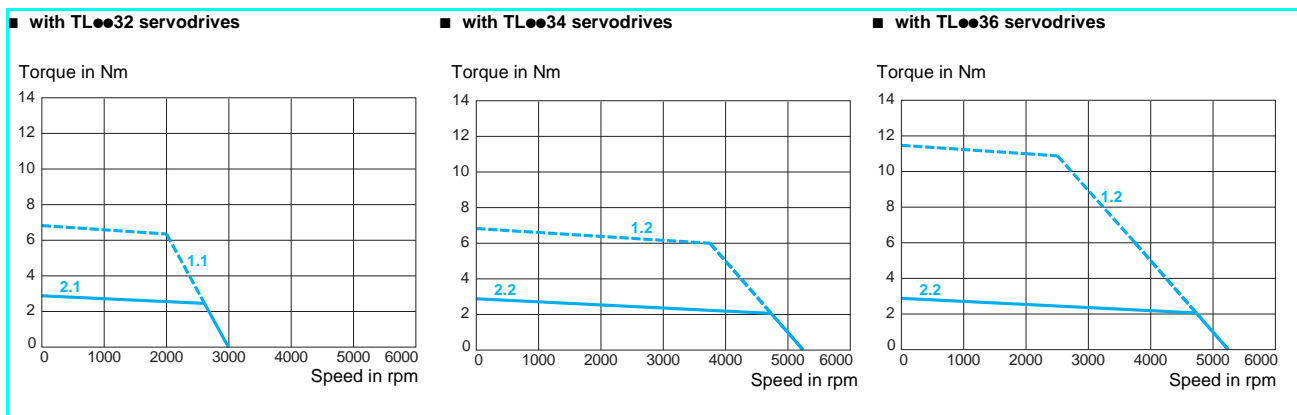

- 1.1 Peak torque at 230 V, single phase
- 1.2 Peak torque at 400 V, 3-phase
- 2.1 Continuous torque at 230 V, single phase
- 2.2 Continuous torque at 400 V 3-phase

Characteristics of SER 39C/39D motors

Type of motor		SER 39C 4L 7S		SER 39D 4L 5S			
		TL●●32	TL●●34	TL●●32	TL●●34	TL●●36	
Torque (model without gearbox)	Associated with the Twin Line servodrive						
	Continuous stall	T_n	Nm	2.9		3.1	3.6
	Peak stall	T_m	Nm	11.5	11.5	6.4	6.4
Current	Permanent		A rms	1.3		3	3.6
	Maximum		A rms	6			17.5
Demagnetization current			A	6		17.5	
Maximum mechanical speed			rpm	6000			
Constants (at 25°C)	Torque		Nm/A rms	2.2		1.03	
	Back emf		V rms s/rad	1.35		0.62	
Rotor	Number of poles			8			
	Inertia without brake	J_m	gm ²	0.24		0.32	
	Inertia with brake	J_m	gm ²	0.26		0.34	
Stator (at 25 °C)	Resistance (phase/phase)		Ω	27.5		4.2	
	Inductance (phase/phase)		mH	11.5		18.6	
	Electrical time constant		ms	4.2		4.4	
Holding brake (depending on model)				See page 64			
Gearbox (depending on model)				See page 66			

Speed/torque graphs

SER Motors 39C 4L 7S

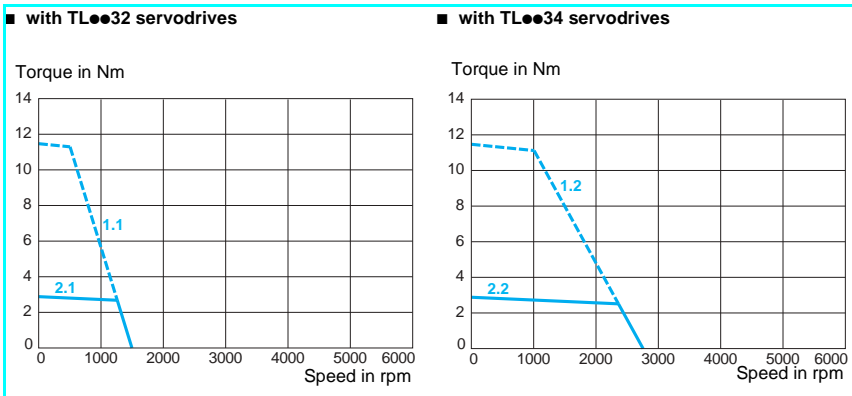

SER Motors 39D 4L 5S

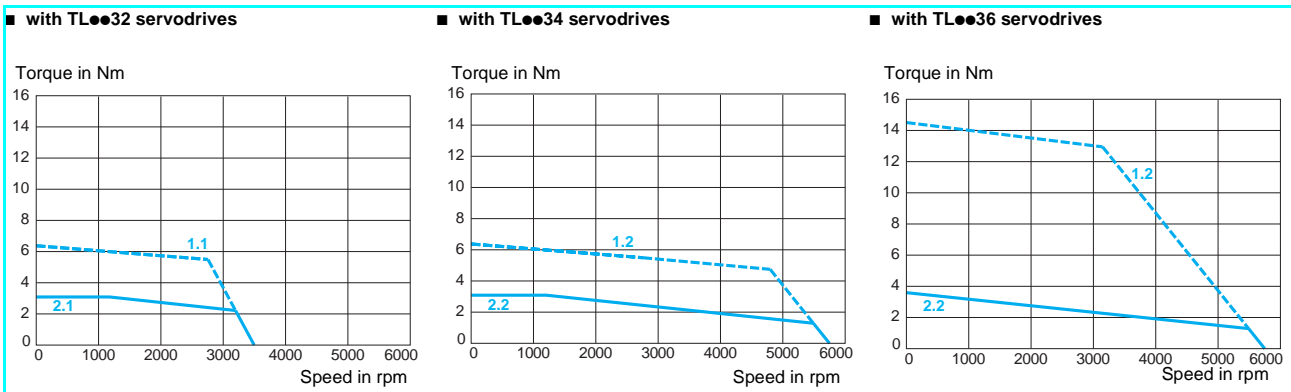

- 1.1 Peak torque at 230 V, single phase
- 1.2 Peak torque at 400 V, 3-phase
- 2.1 Continuous torque at 230 V, single phase
- 2.2 Continuous torque at 400 V 3-phase

Characteristics of SER 3BA motors

Type of motor		SER 3BA 4L 3S					
Associated with the Twin Line (model without gearbox)			TL●●32	TL●●34	TL●●36	TL●●38	
Torque	Continuous stall	T _n	Nm	2.3		4.6	
	Peak stall	T _m	Nm	4.6	4.6	14.5	18
Current	Permanent		A rms	3		6	
	Maximum		A rms	6		20	30
Demagnetization current			A	30			
Maximum mechanical speed			rpm	6000			
Constants (at 25°C)	Torque		Nm/A rms	0.76			
	Back emf		V rms s/rad	0.42			
Rotor	Number of poles			8			
	Inertia without brake	J _m	gm ²	0.4			
	Inertia with brake	J _m	gm ²	0.43			
Stator (at 25 °C)	Resistance (phase/phase)		Ω	1.5			
	Inductance (phase/phase)		mH	12.6			
	Electrical time constant		ms	8.4			
Holding brake (depending on model)				See page 64			
Gearbox (depending on model)				See page 66			

Speed/torque graphs

SER 3BA 4L 3S Motors

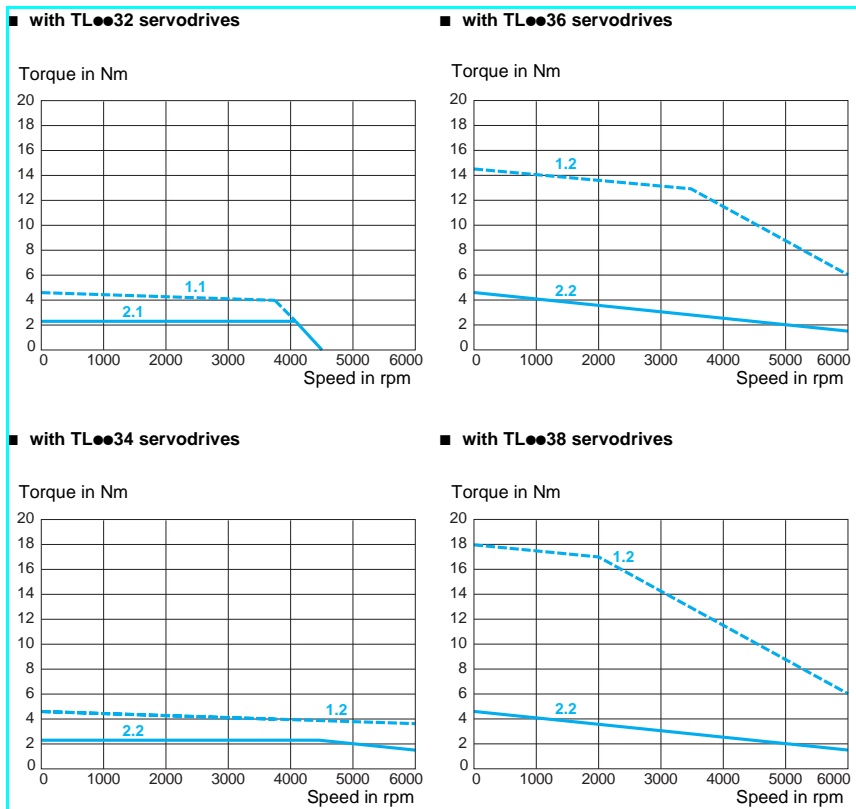

- 1.1 Peak torque at 230 V, single phase
- 1.2 Peak torque at 400 V, 3-phase
- 2.1 Continuous torque at 230 V, single phase
- 2.2 Continuous torque at 400 V 3-phase

Characteristics of SER 3BA motors

Type of motor		SER 3BA 4L 5S			SER 3BA 4L 7S			
Torque (model without gearbox)			TL●●32	TL●●34	TL●●36	TL●●32	TL●●34	TL●●36
Associated with the Twin Line servodrive	Continuous stall	T_n	Nm	4.3		4.6		
	Peak stall	T_m	Nm	7.6	7.6	18	12.8	12.8
Permanent			A rms	3		3.3	1.8	
	Maximum		A rms	6		16.5	6	
Demagnetization current			A	16.5		9		
Maximum mechanical speed			rpm	6000				
Constants (at 25°C)	Torque		Nm/A rms	1.44		2.55		
	Back emf		V rms s/rad	0.7		1.34		
Rotor	Number of poles			8				
	Inertia without brake	J_m	gm ²	0.4				
	Inertia with brake	J_m	gm ²	0.43				
Stator (at 25 °C)	Resistance (phase/phase)		Ω	4.5		18.1		
	Inductance (phase/phase)		mH	40.3		141		
	Electrical time constant		ms	9		7.8		
Holding brake (depending on model)				See page 64				
Gearbox (depending on model)				See page 66				

Speed/torque graphs

SER 3BA 4L 5S Motors

■ with TL●●32 servodrives

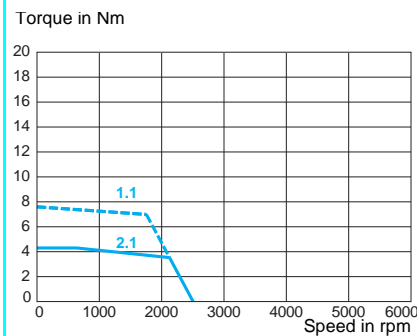

■ with TL●●34 servodrives

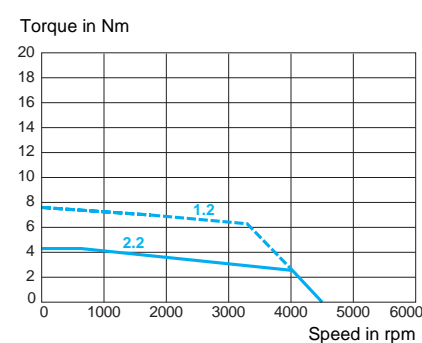

■ with TL●●36 servodrives

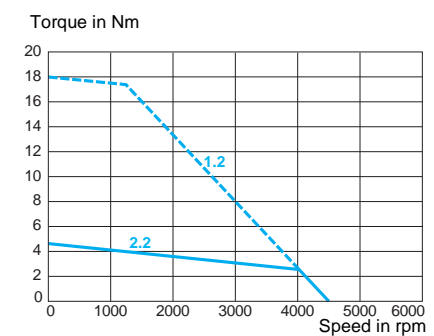

SER 3BA 4L 7S Motors

■ with TL●●32 servodrives

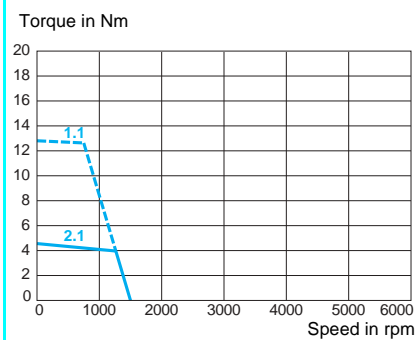

■ with TL●●34 servodrives

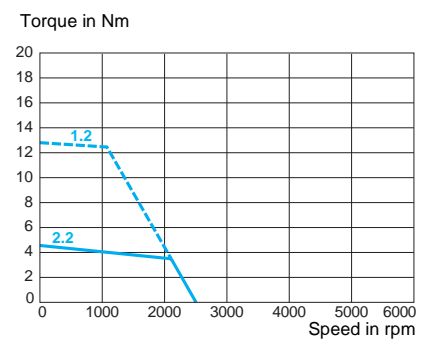

■ with TL●●36 servodrives

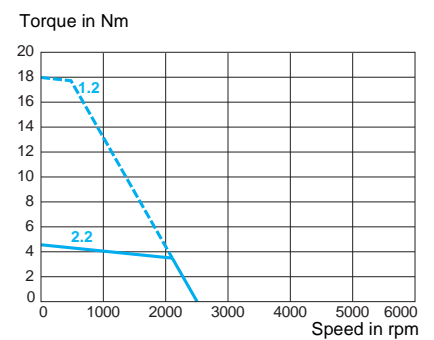

1.1 Peak torque at 230 V, single phase

1.2 Peak torque at 400 V, 3-phase

2.1 Continuous torque at 230 V, single phase

2.2 Continuous torque at 400 V 3-phase

Characteristics of SER 3BB motors

Type of motor			SER 3BB 4L 3S				
Torque (model without gearbox)			TL●●32	TL●●34	TL●●36	TL●●38	
Associated with the Twin Line servodrive	Continuous stall	T _n	Nm	3		6	6.6
	Peak stall	T _m	Nm	6		19	25
Permanent			A rms	3		6	6.6
	Maximum		A rms	6		20	32
Demagnetization current			A	32			
Maximum mechanical speed			rpm	6000			
Constants (at 25°C)	Torque		Nm/A rms	1			
	Back emf		V rms s/rad	0.56			
Rotor	Number of poles			8			
	Inertia without brake	J _m	gm ²	0.8			
	Inertia with brake	J _m	gm ²	0.83			
Stator (at 25 °C)	Resistance (phase/phase)		Ω	1.2			
	Inductance (phase/phase)		mH	11.3			
	Electrical time constant		ms	9.4			
Holding brake (depending on model)				See page 64			
Gearbox (depending on model)				See page 66			

Speed/torque graphs

SER 3BB 4L 3S Motors

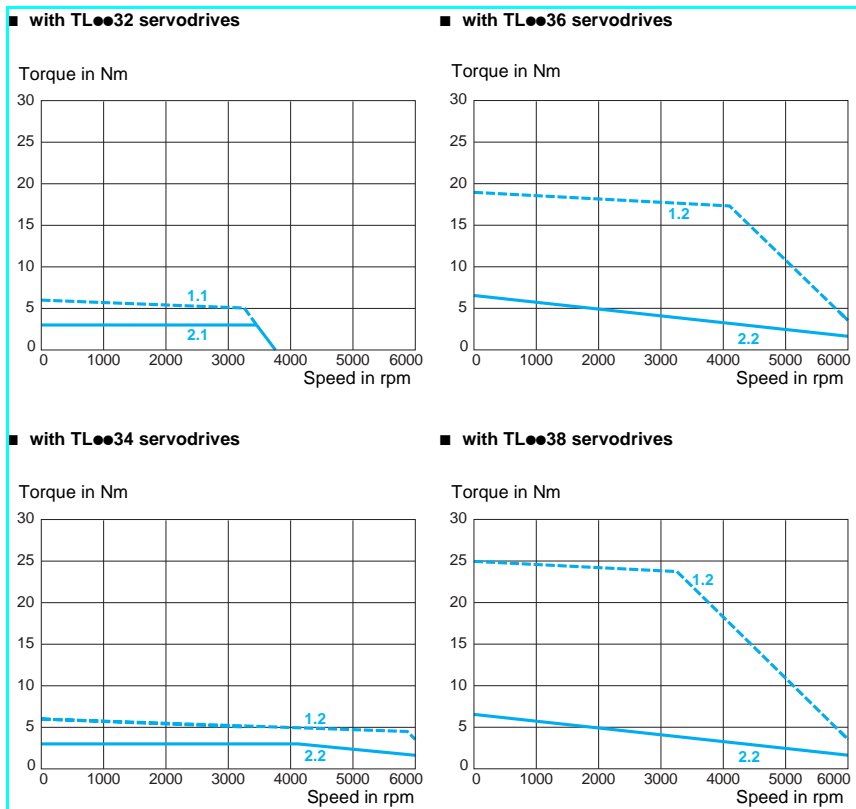

- 1.1 Peak torque at 230 V, single phase
- 1.2 Peak torque at 400 V, 3-phase
- 2.1 Continuous torque at 230 V, single phase
- 2.2 Continuous torque at 400 V 3-phase

Characteristics of SER 3BB motors

Type of motor		SER 3BB 4L 5S				
			TL●●32	TL●●34	TL●●36	TL●●38
Torque (model without gearbox)	Associated with the Twin Line servodrive					
	Continuous stall	T_n	Nm	4		6.6
	Peak stall	T_m	Nm	8	8	19.5
Current	Permanent		A rms	3		5
	Maximum		A rms	6		20
Demagnetization current			A	24		
Maximum mechanical speed			rpm	6000		
Constants (at 25°C)	Torque		Nm/A rms	1.32		
	Back emf		V rms s/rad	0.78		
Rotor	Number of poles			8		
	Inertia without brake	J_m	gm ²	0.8		
	Inertia with brake	J_m	gm ²	0.83		
Stator (at 25 °C)	Resistance (phase/phase)		Ω	2.3		
	Inductance (phase/phase)		mH	21.2		
	Electrical time constant		ms	9.2		
Holding brake (depending on model)				See page 64		
Gearbox (depending on model)				See page 66		

Speed/torque graphs

SER 3BB 4L 5S Motors

■ with TL●●32 servodrives

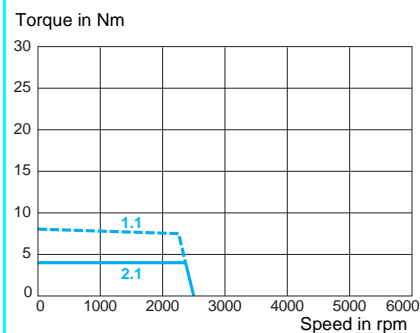

■ with TL●●36 servodrives

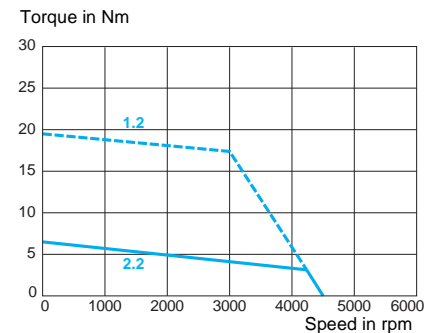

■ with TL●●34 servodrives

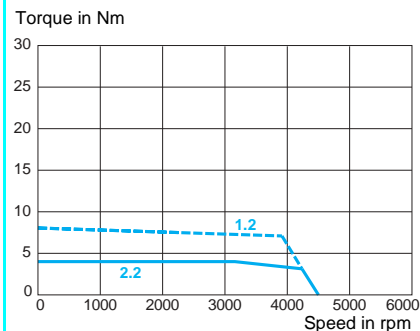

■ with TL●●38 servodrives

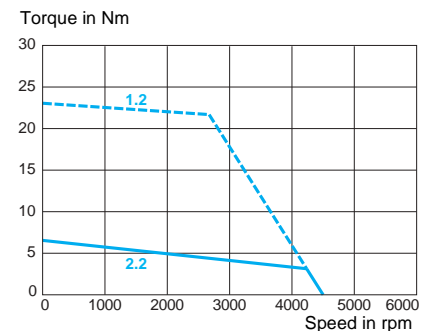

1.1 Peak torque at 230 V, single phase

1.2 Peak torque at 400 V, 3-phase

2.1 Continuous torque at 230 V, single phase

2.2 Continuous torque at 400 V 3-phase

Characteristics of SER 3BB motors

Type of motor		SER 3BB 4L 7S			
Torque (model without gearbox)			TL●●32	TL●●34	TL●●36
Associated with the Twin Line servodrive	Continuous stall	Tn	Nm	6.6	
	Peak stall	Tm	Nm	15	25
Current	Permanent		A rms	2.7	
	Maximum		A rms	6	12.5
Demagnetization current			A	12.5	
Maximum mechanical speed			rpm	6000	
Constants (at 25°C)	Torque		Nm/A rms	2.44	
	Back emf		V rms s/rad	1.42	
Rotor	Number of poles			8	
	Inertia without brake	Jm	gm ²	0.8	
	Inertia with brake	Jm	gm ²	0.83	
Stator (at 25 °C)	Resistance (phase/phase)		Ω	7.4	
	Inductance (phase/phase)		mH	70.2	
	Electrical time constant		ms	9.5	
Holding brake (depending on model)				See page 64	
Gearbox (depending on model)				See page 66	

Speed/torque graphs

SER 3BB 4L 7S Motors

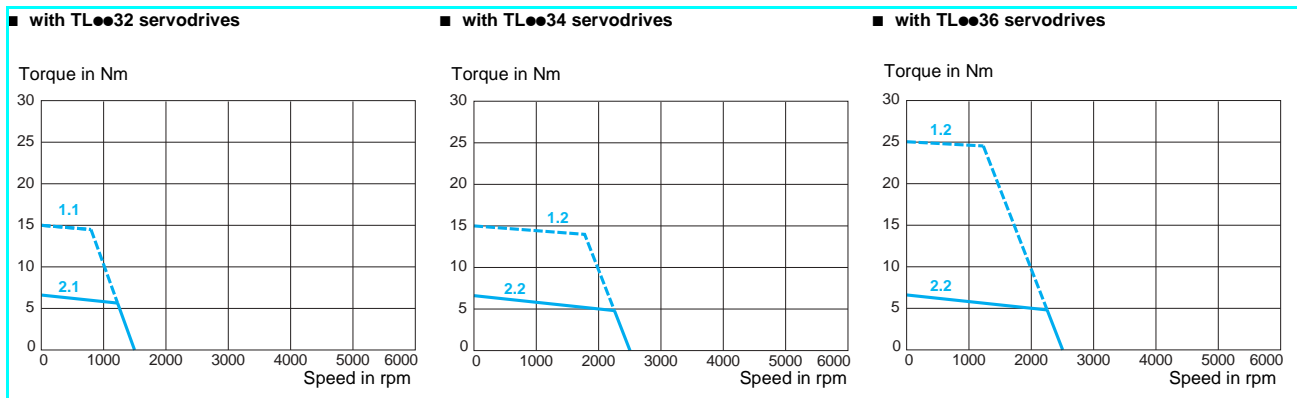

- 1.1 Peak torque at 230 V, single phase
- 1.2 Peak torque at 400 V, 3-phase
- 2.1 Continuous torque at 230 V, single phase
- 2.2 Continuous torque at 400 V 3-phase

Characteristics of SER 3BC motors

Type of motor		SER 3BC 4L 5S					
			TL●●32	TL●●34	TL●●36	TL●●38	
Torque (model without gearbox)	Associated with the Twin Line servodrive						
	Continuous stall	T_n	Nm	4.3		8.5	10
	Peak stall	T_m	Nm	8.5	8.5	27	38
Current	Permanent		A rms	3		6	7
	Maximum		A rms	6		20	32
Demagnetization current			A	32			
Maximum mechanical speed			rpm	4500			
Constants (at 25°C)	Torque		Nm/A rms	1.43			
	Back emf		V rms s/rad	0.87			
Rotor	Number of poles			8			
	Inertia without brake	J_m	gm ²	1.13			
	Inertia with brake	J_m	gm ²	1.17			
Stator (at 25 °C)	Resistance (phase/phase)		Ω	1.7			
	Inductance (phase/phase)		mH	17.2			
	Electrical time constant		ms	10.1			
Holding brake (depending on model)				See page 64			
Gearbox (depending on model)				See page 66			

Speed/torque graphs

SER 3BC 4L 5S Motors

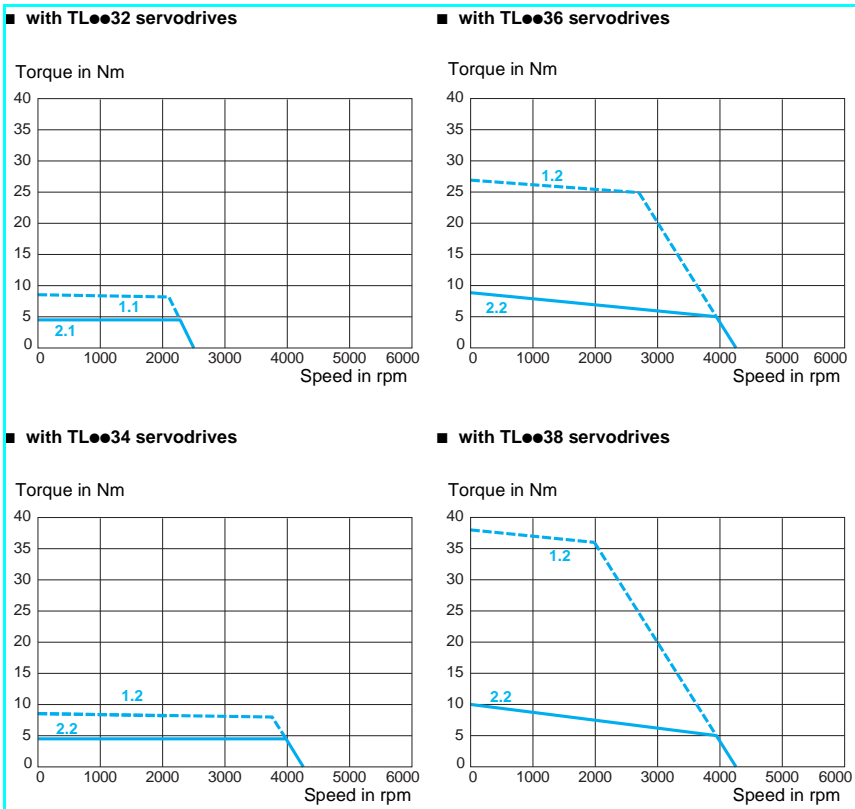

- 1.1 Peak torque at 230 V, single phase
- 1.2 Peak torque at 400 V, 3-phase
- 2.1 Continuous torque at 230 V, single phase
- 2.2 Continuous torque at 400 V 3-phase

Characteristics of SER 3BC motors

Type of motor			SER 3BC 4L 7S			
Torque (model without gearbox)			TL●●32	TL●●34	TL●●36	TL●●38
Associated with the Twin Line servodrive	Continuous stall	Tn Nm	8.3		10	
	Peak stall	Tm Nm	16.5	16.5	38	38
Permanent		A rms	3			3.6
	Maximum	A rms	6			16.5
Demagnetization current			A	16.5		
Maximum mechanical speed			rpm	4500		
Constants (at 25°C)	Torque	Nm/A rms	2.78			
	Back emf	V rms s/rad	1.68			
Rotor	Number of poles		8			
	Inertia without brake	Jm gm ²	1.13			
	Inertia with brake	Jm gm ²	1.17			
Stator (at 25 °C)	Resistance (phase/phase)	Ω	5.7			
	Inductance (phase/phase)	mH	62.5			
	Electrical time constant	ms	11			
Holding brake (depending on model)			See page 64			
Gearbox (depending on model)			See page 66			

Speed/torque graphs

SER 3BC 4L 7S Motors

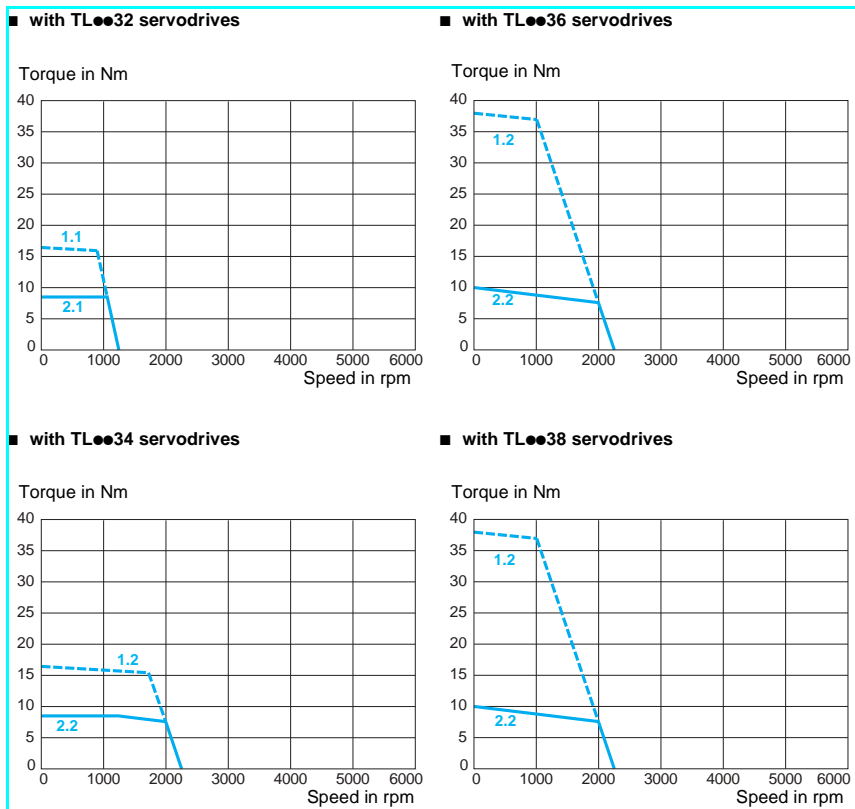

- 1.1 Peak torque at 230 V, single phase
- 1.2 Peak torque at 400 V, 3-phase
- 2.1 Continuous torque at 230 V, single phase
- 2.2 Continuous torque at 400 V 3-phase

Characteristics of SER 3BD motors

Type of motor			SER 3BD 4L 5D		SER 3BD 4L 7S			
Torque (model without gearbox)	Associated with the Twin Line servodrive		TL●●36	TL●●38	TL●●32	TL●●34	TL●●36	TL●●38
	Continuous stall	T_n	Nm	8.7	13.4	7.9	13.4	
	Peak stall	T_m	Nm	26.8	40	15.7	39	48
Current	Permanent		A rms	6	9.2	3	5.1	
	Maximum		A rms	20	32	6	20	25
Demagnetization current			A	45	25			
Maximum mechanical speed			rpm	4500				
Constants (at 25°C)	Torque		Nm/A rms	1.46	2.62			
	Back emf		V rms s/rad	0.84	1.53			
Rotor	Number of poles			8				
	Inertia without brake	J_m	gm ²	0.16				
	Inertia with brake	J_m	gm ²	0.19				
Stator (at 25 °C)	Resistance (phase/phase)		Ω	1.3	3.75			
	Inductance (phase/phase)		mH	14.5	41.5			
	Electrical time constant		ms	11.2	11.1			
Holding brake (depending on model)				See page 64				
Gearbox (depending on model)				See page 66				

Speed/torque graphs

Motors SER 3BD 4L 5D

SER 3BD 4L 7S

■ with TL●●36 servodrives

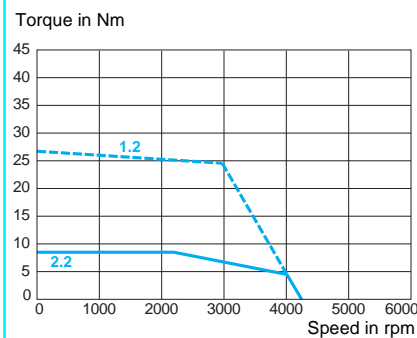

■ with TL●●32 servodrives

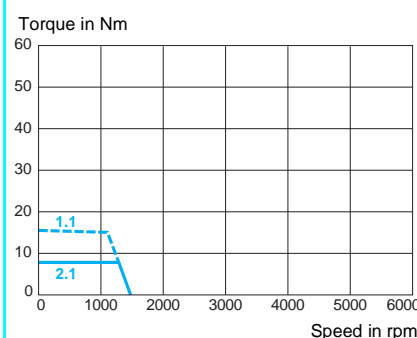

■ with TL●●36 servodrives

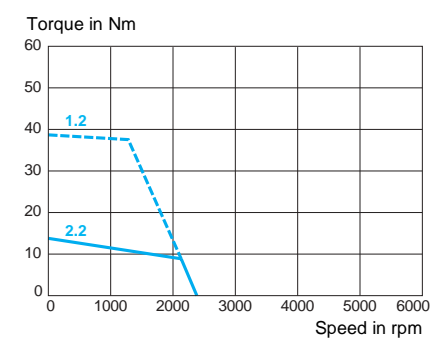

■ with TL●●38 servodrives

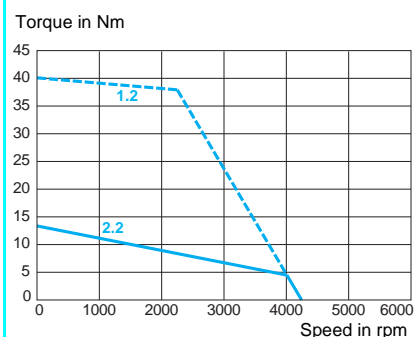

■ with TL●●34 servodrives

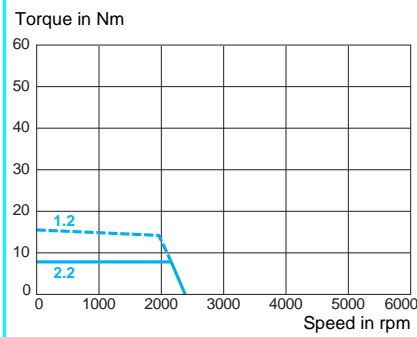

■ with TL●●38 servodrives

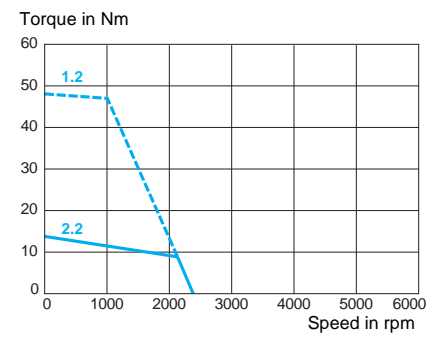

- 1.1 Peak torque at 230 V, single phase
- 1.2 Peak torque at 400 V, 3-phase
- 2.1 Continuous torque at 230 V, single phase
- 2.2 Continuous torque at 400 V 3-phase

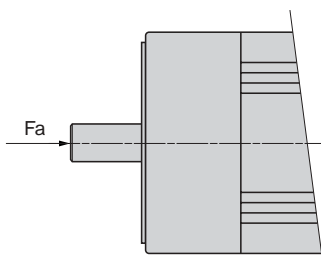
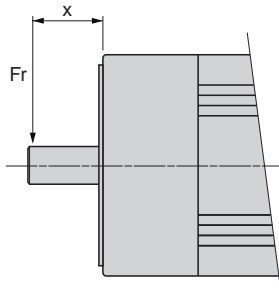

Radial and axial forces permissible on the motor shaft

Even when motors are used under optimum conditions, their lifetime is limited by that of the bearings.

Conditions:

- Nominal lifetime of bearings (1) L10h = 20,000 hours
- Speed N = 4,000 rpm
- Ambient temperature 40 °C
- (temperature of bearings: 100 °C)
- Peak torque cyclic ratio of 10%
- Continuous torque cyclic ratio of 100%
- Force application point X = 10 mm with SER 36● motors
- X = 15 mm with SER 39● motors
- X = 20 mm with SER 3B● motors

(1) Hours of use with a failure probability of 10 %

⚠ The following conditions must be respected:

- Radial and axial forces must not be applied simultaneously.
- The maximum pressure permissible on the shaft end is 1,800 N.
- Shaft end with IP 41 or IP 56 degree of protection.
- Bearings cannot be changed by the user as the built-in position sensor must be realigned after disassembly of the apparatus.

SER motors			364	366	368	36A	39A	39B	39C	39D	3BA	3BB	3BC	3BD
Maximum radial force Fr	Cyclic ratio 10 %	N	231	275	302	320	600	520	500	500	1480	1550	1530	760
	Cyclic ratio 100 %	N	89	107	117	124	340	400	430	450	690	800	860	760
Maximum axial force Fa	Cyclic ratio 10 %	N	299				1240				1770			
	Cyclic ratio 100 %	N	104				450				600			

Characteristics of motor-servodrive power connection cables

		TLA CP AAA 0●● 1	TLA CP AAB 0●● 1	TLA CP AAC 0●● 1
External sleeve		PUR orange colored RAL 2003		
Insulation		TPM or PP/PE		
Capacity	pF/m	< 70 (conductors/shielding)		
Number of conductors (shielded)		[(4 x 1.5 mm ²) + (2 x 1.0 mm ²)]	[(4 x 2.5 mm ²) + (2 x 1.0 mm ²)]	[(4 x 4mm ²) + (2 x 1.0 mm ²)]
External diameter	mm	11	13	15
Curvature radius (bend)	mm	110 (suitable for daisy-chaining)	130 (suitable for daisy-chaining)	150 (suitable for daisy-chaining)
Working voltage	V	600		
Maximum service length (1)	m	20		
Service temperature	°C	- 15...+ 85 (storage: - 40...+ 85)		
Certification		UL, CSA		

Characteristics of motor-servodrive encoder connection cables

		TLA CF ABA 0●● 1
Type of encoder		SinCos Hiperface Encoder
External sleeve		PUR green colored RAL 6018
Insulation		Polyester
Number of conductors (shielded)		5 x (2 x 0.25 mm ²)+(2 x 0.5 mm ²)
Connector		2 x 15-pin SUB-D type connectors
External diameter	mm	8.5 max
Curvature radius (bend)	mm	85 (suitable for daisy-chaining)
Working voltage	V	300
Maximum length (1)	m	20
Service temperature	°C	- 15...+ 85 (storage: - 40...+ 85)
Certification		UL, CSA

(1) For cable lengths of over 20 m, consult our Regional Sales Office.

Motion control

SER brushless motors for Twin Line servodrives

SER brushless motors



SER 364 3L3S ●●●●

Continuous stall torque	Associated servodrive (1)	Peak stall torque	Maximum mechanical speed	Reference (2)	Weight kg
0.3 Nm	TL● ●32	0.8 Nm	12,000 rpm	SER 364 3L3S ●●●●	1.110
0.3 Nm	TL● ●32	1.1 Nm	12,000 rpm	SER 364 3L5S ●●●●	1.110
0.3 Nm	TL● ●32	1.3 Nm	12,000 rpm	SER 364 3L7S ●●●●	1.110
0.5 Nm	TL● ●32	1.1 Nm	12,000 rpm	SER 366 3L3S ●●●●	1.420
0.5 Nm	TL● ●32	1.6 Nm	12,000 rpm	SER 366 3L5S ●●●●	1.420
0.5 Nm	TL● ●32	2.1 Nm	12,000 rpm	SER 366 3L7S ●●●●	1.420
0.7 Nm	TL● ●32	1.5 Nm	12,000 rpm	SER 368 3L3S ●●●●	1.730
0.7 Nm	TL● ●32	1.9 Nm	12,000 rpm	SER 368 3L5S ●●●●	1.730
0.7 Nm	TL● ●32	3 Nm	12,000 rpm	SER 368 3L7S ●●●●	1.730
0.7 Nm	TL● ●32	1.5 Nm	12,000 rpm	SER 36A 3L3S ●●●●	2.010
0.9 Nm	TL● ●32	2.1 Nm	12,000 rpm	SER 36A 3L5S ●●●●	2.010
0.9 Nm	TL● ●32	3.6 Nm	12,000 rpm	SER 36A 3L7S ●●●●	2.010
1.1 Nm	TL● ●32	2.4 Nm	6000 rpm	SER 39A 4L3S ●●●●	2.200
1.1 Nm	TL● ●32	4 Nm	6000 rpm	SER 39A 4L7S ●●●●	2.200
1.1 Nm	TL● ●34	4 Nm	6000 rpm		
2.2 Nm	TL● ●32	4.2 Nm	6000 rpm	SER 39B 4L3S ●●●●	3.300
2.2/2.2 Nm	TL● ●34/●36	4.2/7.8 Nm	6000 rpm		
2.2 Nm	TL● ●32	8 Nm	6000 rpm	SER 39B 4L7S ●●●●	3.300
2.2 Nm	TL● ●34	8 Nm	6000 rpm		
2.3 Nm	TL● ●32	4.8 Nm	6000 rpm	SER 39C 4L3S ●●●●	4.400
2.3/2.9 Nm	TL● ●34/●36	4.8/11.5 Nm	6000 rpm		
2.9 Nm	TL● ●32	6.8 Nm	6000 rpm	SER 39C 4L5S ●●●●	4.400
2.9/2.9 Nm	TL● ●34/●36	6.8/11.5 Nm	6000 rpm		
2.9 Nm	TL● ●32	11.5 Nm	6000 rpm	SER 39C 4L7S ●●●●	4.400
2.9 Nm	TL● ●34	11.5 Nm	6000 rpm		
3.1 Nm	TL● ●32	6.4 Nm	6000 rpm	SER 39D 4L5S ●●●●	6.100
3.1/3.6 Nm	TL● ●34/●36	6.4/11.5 Nm	6000 rpm		
2.3 Nm	TL● ●32	4.6 Nm	6000 rpm	SER 3BA 4L3S●●●●	5.000
2.3/4.6/4.6 Nm	TL● ●34/●36/ ●38	4.6/14.5/18 Nm	6000 rpm		
4.3 Nm	TL● ●32	7.6 Nm	6000 rpm	SER 3BA 4L5S●●●●	5.000
4.3/4.6 Nm	TL● ●34/●36	7.6/18 Nm	6000 rpm		

(1) The torque information contained in these tables concerns:
the servodrives TL● ●32 powered by 230 V single phase.
the servodrives TL● ●34/●36/●38 powered by 400 V 3-phase.
(2) See notes (2) on the opposite page.

Motion control

SER brushless motors for Twin Line servodrives

SER brushless motors (continued)



SER 3BA 4L7S ●●●●

Continuous stall torque	Associated servodrive (1)	Peak torque torque	Maximum mechanical speed	Reference (2)	Weight kg
4.6 Nm	TL● ●32	12.8 Nm	6000 rpm	SER 3BA 4L7S●●●●	5.000
4.6/4.6 Nm	TL● ●34/●36	12.8/18 Nm	6000 rpm		
3 Nm	TL● ●32	6 Nm	6000 rpm	SER 3BB 4L3S●●●●	8.000
3/6/6.6 Nm	TL● ●34/●36/●38	6/19/25 Nm	6000 rpm		
4 Nm	TL● ●32	8 Nm	6000 rpm	SER 3BB 4L5S●●●●	8.000
4/6.6/6.6 Nm	TL● ●34/●36/●38	8/19.5/23 Nm	6000 rpm		
6.6 Nm	TL● ●32	15 Nm	6000 rpm	SER 3BB 4L7S●●●●	8.000
6.6/6.6 Nm	TL● ●34/●36	15/25 Nm	6000 rpm		
4.3 Nm	TL● ●32	8.5 Nm	4500 rpm	SER 3BC 4L5S●●●●	11.000
4.3/8.5/10 Nm	TL● ●34/●36/●38	8.8/27/38 Nm	4500 rpm		
8.3 Nm	TL● ●32	16.5 Nm	4500 rpm	SER 3BC 4L7S●●●●	11.000
8.3/10/10 Nm	TL● ●34/●36/●38	16.5/38/38 Nm	4500 rpm		
8.7/13.4 Nm	TL● ●36/●38	26.8/40 Nm	4500 rpm	SER 3BD 4L5D●●●●	13.000
7.9 Nm	TL● ●32	15.7 Nm	4500 rpm	SER 3BD 4L7S●●●●	13.000
7.9/13.4/13.4 Nm	TL● ●34/●36/●38	15.7/39/48 Nm	4500 rpm		

(1) The torque information contained in these tables concerns:
the servodrives TL● ●32 powered by 230 V single phase.
the servodrives TL● ●34/●36/●38 powered by 400 V 3-phase.

(2) To order an SER motor, fill out at the end of each reference

		SER 364 3L3S	●	●	●	●	
Sensor integrated in motor	SinCos Hiperface, multiturm encoder	MO					
	SinCos Hiperface, single turn encoder	SO					
Shaft seal Holding brake	IP 41	Without holding brake	A				
		With holding brake	1				
	IP 56	Without holding brake	B				
		With holding brake	2				
Gearbox (see page 64)	Without gearbox				O		
	Shaft end	Smooth				O	
		With key (3)					-
	With gearbox (shaft end with key)						
	Type (4)	PLE 60			1		
		PLE 80			2		
		PLE 120			3		
PLE 160				4			
Reduction ratio	Ratio 3:1					3	
	Ratio 5:1					5	
	Ratio 8:1					8	

(3) For gearboxes equipped with shaft end with key, consult our Regional Sales Office.

(4) For PLE gearboxes, see details page 64.

Dimensions (in mm)

SER 364/366/368/36A

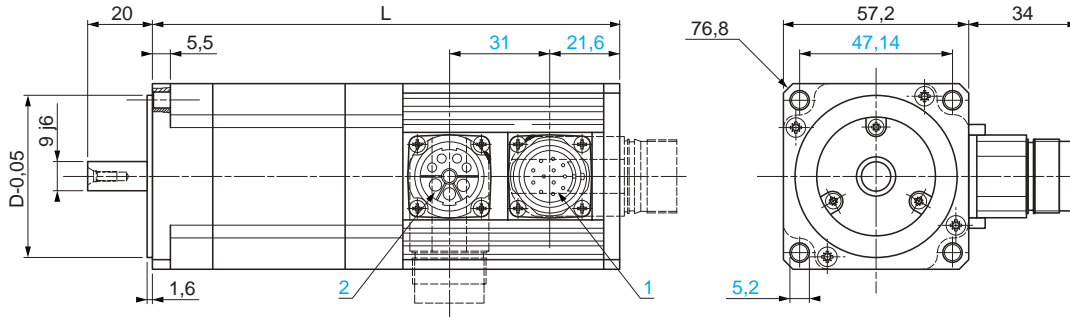

- 1 Encoder connector
- 2 Motor supply connector

	y	∅ D	L (without brake)	L (with brake)
SER 364	9	50	125.8	165.3
SER 366	9	50	144.3	183.8
SER 368	9	50	162.8	202.3
SER 36A	9	50	181.3	220.8

SER 39A/39B/39C/39D

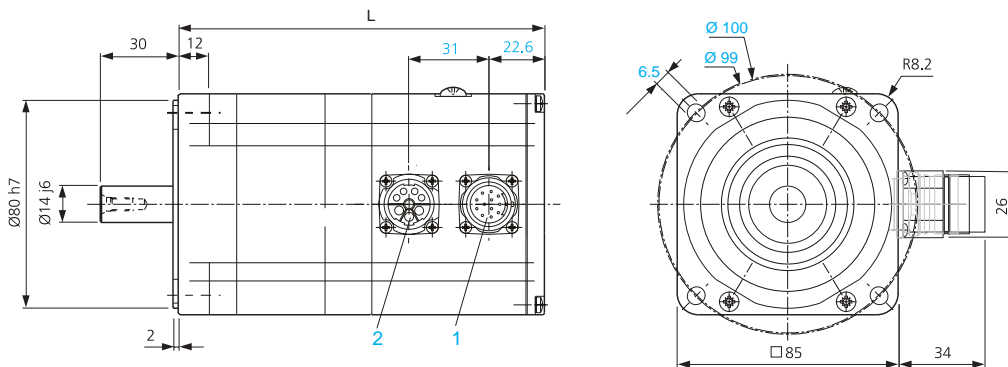

- 1 Encoder connector
- 2 Motor supply connector

	y	∅ D	L (without brake)	L (with brake)
SER 39A	14	80	141	186.5
SER 39B	14	80	171	216.5
SER 39C	14	80	201	246.5
SER 39D	14	80	231	276.5

SER 3BA/3BB/3BC/3BD

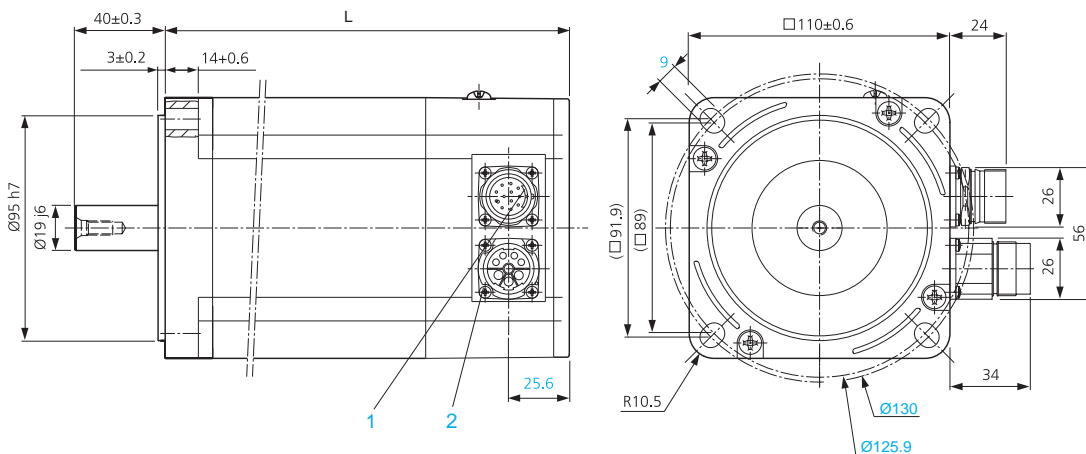

- 1 Encoder connector
- 2 Motor supply connector

	y	∅ D	L (without brake)	L (with brake)
SER 3BA	19	95	132	198
SER 3BB	19	95	180	246
SER 3BC	19	95	228	294
SER 3BD	19	95	276	342

Choice of SinCos Hiperface power cables and encoders

Servodrives TLD/TLC	3 m	5 m	10 m	15 m	20 m (1)	
Cables equipped with 1 connector (motor side)	TL ● ●32	TLA CP AAA 0●●1				
	TL ● ●34					
	TL ● ●36	TLA CP AAB 0●●1				
	TL ● ●38	TLA CP AAC 0●●1				
Cables fitted with connectors at both ends	SinCos Hiperface encoder	TLA CF ABA 0●●1				

Connecting cables

Cables equipped with 1 connector (motor side)

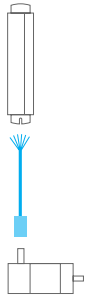

TLA CP AA●0●●1

Description	From	To	Composition	Length (1)	Reference	Weight kg
Power cables (for use with servodrives, see table above)	SER Motors	Twin Line servodrives TLD/TLC	[(4 x 1.5 mm ²) + (2 x 1 mm ²)]	3 m	TLA CP AAA 003 1	–
				5 m	TLA CP AAA 005 1	–
				10 m	TLA CP AAA 010 1	–
				15 m	TLA CP AAA 015 1	–
				20 m	TLA CP AAA 020 1	–
				3 m	TLA CP AAB 003 1	–
			5 m	TLA CP AAB 005 1	–	
			10 m	TLA CP AAB 010 1	–	
			15 m	TLA CP AAB 015 1	–	
			20 m	TLA CP AAB 020 1	–	
			3 m	TLA CP AAC 003 1	–	
			5 m	TLA CP AAC 005 1	–	
10 m	TLA CP AAC 010 1	–				
15 m	TLA CP AAC 015 1	–				
20 m	TLA CP AAC 020 1	–				

Cables fitted with connectors at both ends

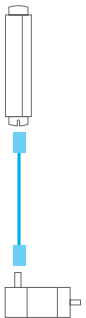

TLA CF ABA 0●●1

Description	From	To	Composition	Length (1)	Reference	Weight kg
SinCos Hiperface encoder cables fitted with two connectors	SER Motors	Twin Line servodrives TLD/TLC	[5 x (2 x 0.25 mm ²) + 1 x (2 x 0.5 mm ²)]	3 m	TLA CF ABA 003 1	–
				5 m	TLA CF ABA 005 1	–
				10 m	TLA CF ABA 010 1	–
				15 m	TLA CF ABA 015 1	–
				20 m	TLA CF ABA 020 1	–

(1) For cable lengths of over 20 m, consult our Regional Sales Office.

Motion control

SER motor options for Twin Line servodrives

Holding brake and encoder

Presentation

Holding brake

The holding brake is an electromagnetic pressure spring brake that blocks the motor's axle when the motor's current has been switched off. In case of an emergency, such as a power outage or an emergency stop, the drive is immobilized, significantly increasing safety. The blocking of the motor's axis is also necessary in cases of torque overload, such as in the case of vertical axis movement.

The holding brake is activated using the external control device TLA BHO which is available as an option.

When this mechanism is in use, heating of the brake is lessened by reducing the control voltage.

Warning! Overloads can damage the holding brake! Avoid static charges of more than 25% of the motor's holding torque with a vertical axis and holding brake.

Encoder

The standard measuring device is the single turn or multturn SinCos Hiperface . This measurement device is perfectly suitable for the Twin Line range of controls. The use of this interface allows the motor to be identified by the servodrive and the control loops of the drive to be automatically initialized. This significantly facilitates installation.

Characteristics

Holding brake

Type of motor		SER 36●	SER 39●	SER 3B●
Holding torque M_{Br}	Nm	1.2	6	16
Inertia of rotor (brake only) J_{Br}	kgcm ²	0.07	0.2	0.35
Electrical clamping power P_{Br}	W	10	24	28
Supply voltage	V	24		
Current	A	0.42	1	1.17
Opening time	ms	14	40	60
Closing time	ms	13	20	30
Weight (brake only)	kg	0.300	1.800	3.000

Encoders

Type of encoder		SinCos single turn	SinCos multiturn
Resolution using a Twin Line servodrive	points/ rpm	16384	16384
Precision of encoder (non-linear)	arc second	± 45	± 45
Measurement method		High resolution, optical	High resolution, optical
Interface		Hiperface	Hiperface
Module required		HIFA-C	HIFA-C
Operating temperature range	°C	- 20...+ 115	- 20...+ 115

Motion control

SER motor options for Twin Line servodrives PLE gearboxes

Presentation (continued)

SER motors are also available with mounted PLE-type gearboxes. Schneider Electric has selected and standardized the following gearbox models, available in a choice of 3 speed reduction ratios 3:1, 5:1 and 8:1. The continuous stall torque and peak stall torque values available from the gearbox are obtained by multiplying the characteristic values of the motor by the reduction ratio and the efficiency of the gearbox (0.96).

Type of motor	Associated servodrive	Gearbox 3:1	Gearbox 5:1	Gearbox 8:1
SER 364 ●●●●	TL● ●32	PLE 60	PLE 60	PLE 60
SER 366 ●●●●	TL● ●32	PLE 60	PLE 60	PLE 80
SER 368 ●●●●	TL● ●32	PLE 60	PLE 60	PLE 80
SER 36A ●●●●	TL● ●32	PLE 60	PLE 80	PLE 80
SER 39A 4L3S	TL● ●32	PLE 80	PLE 80	PLE 80
SER 39A 4L7S	TL● ●32	PLE 80	PLE 80	PLE 80
	TL● ●34	PLE 80	PLE 80	PLE 80
SER 39B 4L3S	TL● ●32	PLE 80	PLE 80	PLE 80
	TL● ●34	PLE 80	PLE 80	PLE 80
	TL● ●36	PLE 80	PLE 80	PLE 120
SER 39B 4L7S	TL● ●32	PLE 80	PLE 80	PLE 120
	TL● ●34	PLE 80	PLE 80	PLE 120
SER 39C 4L3S	TL● ●32	PLE 80	PLE 80	PLE 80
	TL● ●34	PLE 80	PLE 80	PLE 80
	TL● ●36	PLE 80	PLE 80	PLE 120
SER 39C 4L5S	TL● ●32	PLE 80	PLE 80	PLE 80
	TL● ●34	PLE 80	PLE 80	PLE 80
	TL● ●36	PLE 80	PLE 80	PLE 120
SER 39C 4L7S	TL● ●32	PLE 80	PLE 80	PLE 120
	TL● ●34	PLE 80	PLE 80	PLE 120
SER 39D 4L5S	TL● ●32	PLE 80	PLE 80	PLE 80
	TL● ●34	PLE 80	PLE 80	PLE 80
	TL● ●36	PLE 80	PLE 80	PLE 120
SER 3BA 4L3S	TL● ●32	PLE 80	PLE 80	PLE 80
	TL● ●34	PLE 80	PLE 80	PLE 80
	TL● ●36	PLE 80	PLE 80	PLE 120
	TL● ●38	PLE 120	PLE 120	PLE 120
SER 3BA 4L5S	TL● ●32	PLE 80	PLE 80	PLE 120
	TL● ●34	PLE 80	PLE 80	PLE 120
	TL● ●36	PLE 120	PLE 120	PLE 120
SER 3BA 4L7S	TL● ●32	PLE 80	PLE 120	PLE 120
	TL● ●34	PLE 80	PLE 120	PLE 120
	TL● ●36	PLE 120	PLE 120	PLE 120
SER 3BB 4L3S	TL● ●32	PLE 80	PLE 80	PLE 80
	TL● ●34	PLE 80	PLE 80	PLE 80
	TL● ●36	PLE 80	PLE 80	PLE 120
	TL● ●38	PLE 120	PLE 120	PLE 160
SER 3BB 4L5S	TL● ●32	PLE 80	PLE 80	PLE 120
	TL● ●34	PLE 80	PLE 80	PLE 120
	TL● ●36	PLE 80	PLE 120	PLE 120
	TL● ●38	PLE 120	PLE 120	PLE 160
SER 3BB 4L7S	TL● ●32	PLE 80	PLE 120	PLE 120
	TL● ●34	PLE 80	PLE 120	PLE 120
	TL● ●36	PLE 120	PLE 120	PLE 160
SER 3BC 4L5S	TL● ●32	PLE 80	PLE 80	PLE 120
	TL● ●34	PLE 80	PLE 80	PLE 120
	TL● ●36	PLE 80	PLE 120	PLE 120
	TL● ●38	PLE 120	PLE 120	PLE 160
SER 3BC 4L7S	TL● ●32	PLE 80	PLE 120	PLE 120
	TL● ●34	PLE 80	PLE 120	PLE 120
	TL● ●36	PLE 120	PLE 160	PLE 160
	TL● ●38	PLE 120	PLE 160	PLE 160
SER 3BD 4L5D	TL● ●36	PLE 120	PLE 120	PLE 160
	TL● ●38	PLE 120	PLE 160	PLE 160
SER 3BD 4L7S	TL● ●32	PLE 80	PLE 120	PLE 120
	TL● ●34	PLE 80	PLE 120	PLE 120
	TL● ●36	PLE 120	PLE 160	PLE 160
	TL● ●38	PLE 120	PLE 160	PLE 160

Motion control

SER motor options for Twin Line servodrives PLE gearboxes

Characteristics					
Type of gearbox		PLE 60	PLE 80	PLE 120	PLE 160
Type of gearbox		Planetary gearbox with single reduction stage, straight teeth			
Backlash	min arc	< 20	< 12	< 8	< 6
Torsion rigidity	Nm/ min arc	1.5	4.5	11	32.5
Noise level	dB (A)	58	60	65	70
Junction box		Black anodized aluminum			
Shaft material		C 45			
Tightness of shaft output		IP 43			
Lubrication		No lubrication required			
Average lifetime (1)	h	10 000: S1 mode (permanent service) and 100% continuous torque 20 000: S1 mode (permanent service) and 85% continuous torque			
Mounting position		All positions			
Operating temperature		°C - 25...+ 90 (Shot term, + 120)			
Weight (gearbox only)	kg	0.900	2.100	6.000	18.000

Combining an SER motor with a PLE gearbox						
Type of gearbox		PLE 60	PLE 80	PLE 120	PLE 160	
Efficiency		0.96				
Maximum permitted radial force (2) (3)		N	500	950	2000	6000
Maximum permitted axial force (2)		N	600	1200	2800	8000
Inertia of gearbox	3:1	kgcm ²	0.135	0.77	2.63	12.14
	5:1	kgcm ²	0.078	0.45	1.53	6.07
	8:1	kgcm ²	0.065	0.39	1.32	4.63
Continuous output torque <i>T_{2N}</i>	3:1	Nm	12	40	80	400
	5:1	Nm	16	50	110	450
	8:1	Nm	15	50	120	450

(1) Data in operating hours for a 10% fault probability rating.

(2) Values given for a minimum lifetime of 10,000 hours at an output speed of 100 rpm for a cyclic ratio = 1 (S1 mode) on electrical machines.

(3) Force applied at mid-distance from the output shaft.

Motion control

SER motor options for Twin Line servodrives
PLE gearboxes

Dimensions in mm

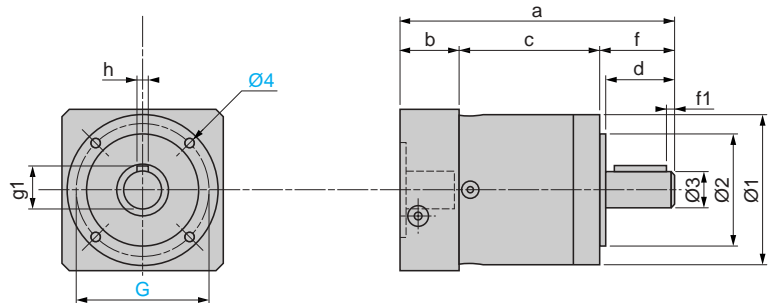

	PLE 60	PLE 80	PLE 120	PLE 160
a	106.5	134	176.5	255.5
b	24.5	33.5	47.5	64.5
c	47	60.5	74	104
d	30	36	50	80
f	35	40	55	87
f1	2.5	4	5	8
g1	16	22.5	28	43
h	5	6	8	12
Ø1	60	80	115	160
Ø2 (1)	40	60	80	130
Ø3 (1)	14	20	25	40
G	52	70	100	145
Ø4	M5 x 8	M6 x 10	M10 x 16	M12 x 20

(1) Tolerance H7.

Motion control









Automation product certifications

Product certifications and marine classification authorities

In some countries, certification of certain electrical components is enforced by law. A standard conformity certificate is then issued by the official organization. Each certified product must carry approval symbols when enforced. Use on board merchant navy vessels generally requires prior approval (= certification) of an electrical device by certain marine classification authorities.

Key	Certification body	Country
CSA	Canadian Standards Association	Canada
C-Tick	Australian Communication Authority	Australia
UL	Underwriters Laboratories	USA
Key	Classification authority	Country
ABS	American Bureau of Shipping	USA
BV	Bureau Veritas	France
DNV	Det Norske Veritas	Norway
GL	Germanischer Lloyd	Germany
GOST	Institut de recherche Scientifique Gost Standardt	C.I.S.
LR	Lloyd's Register	United-Kingdom
RINA	Registro Italiano Navale	Italy
RRS	Register of Shipping	C.I.S.

The table below shows the situation as of the 01.05.2003 for certifications obtained or pending from organizations for base PLCs. Further information regarding certified modules can be obtained from your Regional Sales Office.









	Certifications				Others		
	 CSA Class 1 Div 2 Canada	 ACA Australia	 SIMTARS Australia	 UL USA	 Class 1 Div 2 Hazardous locations Etats-Unis	 BG Germany	 AS-i Europe
Normal execution							
	Certified						
	Pending certification						
ABE-7				E164866			
CCX 17				E95257			
Lexium MHD/BPH							
Magelis IPC				E95257			
Magelis TXBT-F	LR 44087-77	N998					
Magelis XBT-F/FC	LR 44087-77	N998					
Magelis XBT-H/P/E/HM/PM	LR 44087-77			E95257			
Micro	LR 58905-30	N998	NI97/0039 Ex2314X	E95257	LR 58905-30	(1)	(2)
Momentum		N998					
Nano	LR 58905-42	N998		E95257			
Premium	LR 58905-32S	N998	NI97/0039 Ex2314X	E95257	LR 58905-32S	(3)	(4)
Quantum							(5)
TBX	LR 58905-21 LR 58905-21 (S)	N998		E95257			
TSX/PMX 47 to 107	LR 58905-00			E95257			(6)
Twin Line TLD/TLC/SER							

- (1) TSX DPZ 10D2A safety module.
 (2) TSX SAZ 10 AS-i bus master module and TSX SUP A02/A05 AS-i bus power supplies.
 (3) TSX PAY 262/282 safety modules.
 (4) TSX SAY 100 AS-i bus master modules.
 (5) 140 EIA 921 00 AS-i bus master module.
 (6) TBX SAP 10 Fipio/AS-i gateway.

Motion control

Automation Product Certifications

Product certifications and marine classification authorities (continued)

	Sociétés de classification des navires								
									
	ABS US	BV France	CCS China	DNV Norway	GL Germany	GOST CEI	LR United-Kingdom	RINA Italy	RRS CIS
Normal execution									
ABE-7					99155-96HH				
CCX 17									
Lexium MHD/BPH									
Magelis IPC									
Magelis TXBT-F									
Magelis XBT-F/FC									
Magelis XBT-H/P/E/HM/PM									
Micro	01-LD2639 15-PDA	450 16846001	BLP987200 51/2	A7961	99086-96HH		97/00114	ELE/ 48896/1	01.188.011
Momentum									
Nano		450 17055001	BLP987200 51/3	A7773			Temporary MSL/ 990159		
Premium	00MS 14569-X 00-LD1868 57-PDA	4501H 07135/B0	BLP987200 51/1	A8206	99405-97HH		98/00088	ELE/ 35897/1	01.184.011
Quantum	00NY 5610-X			A7834	17 315-00HH		01/60002	MAC/ 13299CS1	01.186.011
TBX		450 37058A001		A7952	99405-97HH			ELE/ 43795/2	
TSX/PMX 47 à 107 (Serie 7)		450 15106D001		A7952	94511HH			ELE/ 43795/3 (TSX P107)	96089250 (TSX 47)
Twin Line TLD/TLC/SER									

Conformity to European Directives: C€ marquing

All products are conformed to C€ marquing.
See Community regulations page 74.



Schneider Electric worldwide

Up-dated: 22-03-2002

Algeria	■ Schneider Electric	15 chemin Poirson 16030 El-Biar Alger	Tel. : +213 21 92 97 02 à 09 Fax : +213 21 92 97 00 à 01	
Argentina	■ Schneider Argentina	Viamontia 2850 - 1678 Caseros (provincia Buenos Aires)	Tel.: +54 1 716 88 88 Fax: +54 1 716 88 77	www.schneider-electric.com.ar
Australia	■ Schneider Electric (Australia) Pty. Limited	2 Solent Circuit Norwest Business Park Baulkham Hill _ NSW 2153	Tel.: +61 298 51 28 00 Fax: +61 296 29 83 40	www.schneider.com.au
Austria	■ Schneider Austria Ges.m.b.H.	Birostrasse 11 1239 Wien	Tel.: +431 610 540 Fax: +431 610 54 54	www.schneider-electric.at
Bahrain	■ Schneider Electric	Floor 1 - Juma Building Abu Horaira Avenue PO Box 355 - 304 Manama	Tel.: +97 322 7897 Fax: +97 321 8313	
Belarus	■ Schneider Electric Industries SA	Prospect Macherova 5, of. 202 220004 Minsk	Tel. : +375 172 23 75 50 Fax : +375 172 23 97 61	
Belgium	■ Schneider Electric nv/sa	Dieweg 3 B - 1180 Brussels	Tel.: +3223737711 Fax: +3223753858	www.schneider-electric.be
Brazil	■ Schneider Electric Brasil Ltda.	Avenida Das Nações Unidas 23223 Jurubatuba - CEP 04795-907 São Paulo-SP	Tel.: +55 55 24 52 33 Fax: +55 55 22 51 34	www.schneider-electric.com.br
Bulgaria	■ Schneider Electric	Expo 2000, Boulevard Vaptzarov 1407 Sofiav	Tel.: +3592 919 42 Fax: +3592 962 44 39	www.schneiderelectric.bg
Cameroon	■ Schneider Electric Cameroun	16, rue de l'Hôtel de Ville BP12087 - Douala	Tel.: +237 42 69 30 Fax: +237 43 11 94	
Canada	■ Schneider Canada	19, Waterman Avenue M4 B1Y2 Toronto - Ontario	Tel.: +1 416 752 8020 Fax: +1 416 752 4203	www.schneider-electric.ca
Chile	■ Schneider Electric Chile S.A.	Avda. Pdte Ed. Frei Montalva, 6001-31 Conchali - Santiago	Tel.: +56 2 444 3000 Fax: +56 2 423 9335	www.schneider-electric.co.cl
China	■ Schneider Beijing	Landmark bldg-Room 1801 8 North Dong Sanhuan Rd Chaoyang District 100004 Beijing	Tel.: +86 10 65 90 69 07 Fax: +86 10 65 90 00 13	www.schneider-electric.com.cn
Colombia	■ Schneider Electric de Colombia S.A.	Calle 45A #102-48 Bogota DC	Tel.: +57 1 426 97 00 Fax: +57 1 426 97 40	
Costa Rica	■ Schneider Centroamérica Ltda.	1.5 kms oeste de la Embajada Americana, Pavas, San José, Costa Rica C.A. Apartado: 4123-1000 San Jose	Tel.: +506 232-60-55 Fax: +506 232-04-26	www.schneider-ca.com
Côte d'Ivoire	■ Schneider Electric Afrique de l'Ouest et Centrale	Rue Pierre et Marie Curie 18 BP 2027 Abidjan 18	Tel.: +225 21 75 00 10 Fax: +225 21 75 00 30	
Croatia	■ Schneider Electric SA	Fallerovo Setaliste 22 HR - 10000 Zagreb	Tel.: +385 1 367 100 Fax: +385 1 367 111	
Cuba	■ Schneider Electric	Bureau de Liaison de La Havane Calle 36- N°306-Apto1 Entre 3ra y 5ta Avenida Miramar Playa Habana	Tel.: +53 724 15 59 Fax: +53 724 12 17	
Czech Republic	■ Schneider Electric CZ, s.r.o.	Thámova 13 Praha 8 - 186 00	Tel.: +420 2 810 88 111 Fax: +420 2 24 81 08 49	www.schneider-electric.cz
Denmark	■ Schneider Electric A/S	Baltorpbakken 14 DK-2750 Ballerup	Tel.: +45 44 73 78 88 Fax: +45 44 68 5255	www.schneider-electric.dk
Dominican Republic	■ Schneider Electric	Calle Jacinto Manon Esq. Federico Geraldino Edificio D' Roca Plaza Suite 402, Ens. Paraiso - Santo Domingo	Tel.: +1 809 334 66 63 Fax: +1 809 334 66 68	
Ecuador	■ Schneider Ecuador	Av. de los Shyris y Rio Coca Esq. Edificio Eurocentro Segundo Piso 6466 Quito	Tel.: +593 2 25 03 23 Fax: +593 2 43 49 40	
Egypt	■ Schneider Electric Egypt	68, El Tayaran Street Nasr City, 11371 - Cairo	Tel.: +20 24 01 01 19 Fax: +20 24 01 66 87	www.schneider.com.eg
Estonia	■ Lexel Electric	Ehitajate tee 110 EE 12618 Tallinn	Tel. : +372 650 97 00 Fax : +372 650 97 22	
Finland	■ Schneider Electric Oy	Sinikalliontie 16 02630 Espoo	Tel. : +358 9 5270 0359 Fax : +358 9 5270 0376	www.schneider-electric.fi
France	■ Schneider Electric SA	5, rue Nadar 92500 Rueil Malmaison	Tel.: +33 (0)1 41 29 82 00 Fax: +33 (0)1 47 51 80 20	www.schneider-electric.fr
Germany	■ Schneider Electric GmbH	Gothaer Straße 29 D-40880 Ratingen	Tel.: +49210 240 40 Fax: +492 10 240 49 256	www.schneider-electric.de
Ghana	■ Schneider Electric	Private Mail Bag - Kotoa Airport Accra	Tel. : +23321 70 10 842/11 687 Fax : +233 21 77 96 22	
Greece	■ Schneider Electric AE	14th km - RN Athens-Lamia GR - 14564 Kifissia	Tel.: +3016 29 52 00 Fax: +3016 29 52 10	www.schneider-electric.com.gr



Schneider Electric worldwide

Up-dated: 22-03-2002

Haiti	■ Schneider Electric	Calle Jacinto Manon Esq. Federico Geraldino Edificio D' Roca Plaza Suite 402, Ens. Paraiso - Santo Domingo	Tel.: +809 334 66 63 Fax: +809 334 66 68	
Hong Kong	■ Schneider Electric (Hong Kong) Ltd	Room 3108-28, 31th Floor, Sun Hung Kai Centre, 30 Harbour Road, Wanchai	Tel.: +852 25 65 06 21 Fax: +852 28 11 10 29	
Hungary	■ Schneider Electric Hungária Villamossági Rt.	Fehérvári út 108 – 112 H-1116 Budapest	Tel.: +36 1 382 26-06 Fax: +36 1 206 1429	www.schneider-electric.hu
India	■ Schneider Electric India	Max House, 1 Dr Jha Marg, Okhla 110 020 New Dehli	Tel. : +91 11 631 85 84 Tel. : +91 11 631 71 61	www.schneiderelectric-in.com
Indonesia	■ P.T. Schneider Indonesia	Ventura Building 7th Floor Jalan R.A. Kartini Kav.26 Cilandak 12430 Jakarta	Tel.: +62 +21 750 44 06 Fax: +62 +21 750 44 15/ 16	www.schneider-electric.co.id
Iran (Islamic Republic of)	■ Telemecanique Iran	1047 Avenue VALI ASSR P.O. Box 15875-3547 15116 Teheran	Tel.: +98 218 71 01 42 Fax: +98 218 71 81 87	
Irak	■ Schneider Electric Industries SA	38050 Grenoble Cedex 9	Tel.: +33 04 76 60 54 27 Fax: +33 04 76 60 56 60	
Ireland	■ Schneider Electric Ireland	Maynooth Road Cellbridge - Co. Kildare	Tel.: +353+0 1 6012200 Fax: +353+0 1 6012201	www.schneiderelectric.ie
Italy	■ Schneider Electric S.p.A.	Centro Direzionale Colleoni Palazzo Sirio - Viale Colleoni, 7 20041 Agrate Brianza (Mi)	Tel.: +39 39 655 8111 Fax: +39 39 605 6237	www.schneiderelectric.it
Japan	■ Schneider Electric Japan Ltd	SK Bldg, Sendagaya 4-14-4, Sendagaya Shibuya-Ku - 151 Tokyo	Tel.: +81 354 74 44 74 Fax: +81 354 74 44 70	www.schneider-electric.co.jp
Kazakhstan	■ Schneider Electric Kazakhstan Liaison Office	Prospekt Abaia 157 off 9 480009 Almaty	Tel. : +7 327 250 93 88 Tel. : +7 327 250 63 70	
Kenya	■ Schneider East Africa	Power Technics Complex PO Box 46345 - Nairobi	Tel.: +254 2.824.156 Fax: +254 2.824.157	
Kuwait	■ Schneider Electric Kuwait	Al Gaas Tower - Sharq 2nd Floor PO Box 20092 - 13 061 Safat	Tel.: +965 240 75 46 Fax: +965 240 75 06	
Latvia	■ Lexel Electric	60A A.Deglava str. LV1035 Riga	Tel. : +371 780 23 74/75 Fax : +371 754 62 80	
Lebanon	■ Schneider Electric Lebanon	Ashadia Bldg, 8th Floor Tabaris, Ashrafieh, P.O. Box 166223 Beyrouth	Tel. : +961 1 20 46 20 Tel. : +961 1 20 31 19	
Lithuania	■ Lexel Electric	44, Verkiu str. LT-2012 Vilnius	Tel. : +370 278 59 59/61 Fax : +370 278 59 60	
Malaysia	■ Schneider Electric (Malaysia) Sdn Bhd	No.11 Jalan U1/19, Seksyen U1 Hicom-Glenmarie Industrial Park Shah Alam 40150 Selangor Darul Ehsan	Tel.: +60 37 05 11 50 Fax: +60 37 05 11 70	www.schneider-electric.com.my
Martinique	■ Schneider Electric	Schneider Electric Immeuble Cottrell ZI de la Lézarde 97232 Le Lamentin	Tel.: +05 96 51 06 00 Fax: +05 96 51 11 26	
Mexico	■ Groupe Schneider Mexico	Calz. Rojo Gomez N° 1121 Col. Guadalupe del Moral México 09300	Tel.: +525 686 30 00 Fax: +525 686 24 09	www.schneider-electric.com.mx
Morocco	■ Schneider Electric Maroc	26, rue Ibnou Khalikane Quartier Palmiers 20100 Casablanca	Tel.: +212 299 08 48 to 57 Fax: +212 299 08 67 and 69	www.schneider.co.ma
Netherlands	■ Schneider Electric BV	Waarderweg 40 - Postbus 836 2003 RV Haarlem	Tel.: +31 23 512 4124 Fax: +31 23 512 4100	www.schneider-electric.nl
New Zealand	■ Schneider Electric (NZ) Ltd	14 Charann Place Avondale P.O. Box 15355 - New Lynn Auckland	Tel.: +64 +9 820 1820 Fax: +64 +9 820 1821	
Nigeria	■ Merlin Gerin Nigeria Ltd	Plot 25 Sanni Tola Sonolki Close Off Harold Sodipo Crescent PO Box 12 505 - Ikeja - Lagos	Tel.: +234 14 93 63 99 Fax: +234 14 97 45 99	
Norway	■ Schneider Electric Norge A/S	Solgaard Skog 2 Postboks 128 - 1501 Moss	Tel.: +47 6924 9700 Fax: +47 6925 7871	www.schneider-electric.no
Oman	■ Schneider Electric CA	c/o Arab Development Co PO Box 439 - 113 Muscat	Tel.: +968 77 163 64 Fax: +968 77 104 49	
Pakistan	■ Schneider Electric Pakistan	302 Clifton Center Clifton Block J - Karachi 75500	Tel.: +92 21 586 3561 to 63 Fax: +92 21 586 3564	
Peru	■ Schneider Electric Peru S.A.	Los Telares n°231 Urb. Vulcano, Ate Lima 03	Tel.: +511 348 44 11 Fax: +511 348 05 23	www.schneider-electric.com.pe
Philippines	■ Schneider Electric Philippines, Inc	Schneider Electric Philippines, Inc 1314 Batangas Street Makati City 1234 - Metro-Manila	Tel.: +63 28 44 84 18 Fax: +63 28 16 00 63	



Schneider Electric worldwide

Up-dated: 22-03-2002

Poland	■ Schneider Electric Polska Sp.zo.o.	ul. Domaniewska 41 02-672 - Warszawa	Tel.: +48 22 606 25 00 Fax: +48 22 606 11 66 Fax: +48 22 606 11 58	www.schneider-electric.pl
Portugal	■ Schneider Electric Portugal	Av.do Forte, 3 Edificio Suécia II, Piso 3-A CP 2028 Carnaxide 2795 Linda-A-Velha	Tel.: +351 21 416 5800 Fax: +351 21 416 5857	www.schneiderelectric.pt
Qatar	■ Schneider Electric Qatar Branch	c/o Khalifa BinFahred Al Thani Trad.and Co - P.O. Box 4484 Doha	Tel.: +97 4424358 Fax: +97 4424358	
Reunion	■ Schneider Electric	Immeuble Futura, 190, rue des 2 canons BP 646 - 97497 Sainte Clothilde	Tel.: +262 28 14 28 Fax: +262 28 39 37	
Romania	■ Schneider Electric	Bd Ficusului n°42 Apimondia, Corp.A, et.1, Sector 1 Bucuresti	Tel.: +401 203 06 50 Fax: +401 232 15 98	www.schneider-electric.ro
Russian Federation	■ Schneider Electric ZAO	Enisseyskaya 37 129 281 Moscow	Tel.: +7095 797 40 00 Fax: +7095 797 40 03	www.schneider-electric.ru
Saudi Arabia	■ Schneider Electric	Second Industrial City P.O. Box 89249 - 11682 Riyadh	Tel.: +966 1 265 1515 Fax: +966 1 265 1860	
Senegal	■ Schneider Electric Sénégal	BP 15952 - Dakar-Fann Rond point N'Gor - Dakar	Tel.: +221 820 68 05 Fax: +221 820 58 50	
Singapore	■ Schneider Electric Singapore Pte Ltd	10 Ang Mo Kio Street 65 #02-17/20 TechPoint Singapore 569059	Tel.: +65 484 78 77 Fax: +65 484 78 00	www.schneider-electric.com.sg
Slovak Republic	■ Schneider Electric Slovakia spol s.r.o.	Borekova 10 SK-821 06 Bratislava	Tel.: +4217 552 40 10/20 Fax: +4217 552 40 00	www.schneider-electric.sk
Slovenia	■ Schneider Electric, d.o.o.	Dunasjka 47 1000 Ljubljana	Tel.: +386 1 23 63 555 Fax: +386 1 23 63 559	www.schneider-electric.si
South Africa	■ Schneider Electric South Africa (PTY) Ltd	Cnr Bekker & Montrose roads 1685 - Midrand.	Tel.: +27 11 254 6400 Fax: +27 11 315 8830	www.schneider-electric.co.za
South Korea	■ Schneider Electric Korea	3Floor, Cheil Bldg., 94-46, 7-Ka Youngdeungpodong, Youngdeungpo-ku 150-037 Seoul	Tel.: +82 2 2630 9700 Fax: +82 2 2630 9800	www.csinfo.co.kr/schneider/
Spain	■ Schneider Electric España, S.A.	Pl. Dr. Letamendi, 5-7 08007 Barcelona	Tel.: +34 93 484 3100 Fax: +34 93 484 3308	www.schneiderelectric.es
Sweden	■ Schneider Electric AB	Djupdalsvägen 17/19 19129 Sollentuna	Tel.: +46 8 623 84 00 Fax: +46 8 623 84 85	www.schneider-electric.se
Switzerland	■ Schneider Electric (Switzerland) S.A.	Schermerwaldstrasse 11 Postfach - CH - 3063 Ittigen	Tel.: +41 31 917 3333 Fax: +41 31 917 3355	www.schneider-electric.ch
Syrian Arab Republic	■ Schneider Electric Syria	Shakib Arslan Street - Abou Roumaneh PO Box 33876 - Damas	Tel.: +963 11 333 10 26 Fax: +963 11 331 08 67	
Taiwan, Republic of China	■ Schneider Electric Taiwan Co Ltd	11F-2, N°51, Keelung Road, Sec.2 110 Taipei	Tel.: +886 2 27 33 14 64 Fax: +886 2 27 33 64 10	www.schneider-electric.com.tw
Thailand	■ Schneider (Thailand) Ltd	20th Floor Richmond Building 75 Sukhumvit 26 Road, Klongtoey Bangkok 10110	Tel.: +66 2 324 6000 Fax: +66 2 204 9816	www.schneider-electric.co.th
Tunisia	■ Schneider Electric Tunisie	2045 Les Berges du lac Tunis	Tel.: +216 71 960 477 Fax: +216 71 960 342	
Turkey	■ Schneider Elektrik Sanayi Ve Ticaret A.S.	Tütüncü Mehmet Efendi Cad. N°:110 Kat 1-2 - 81080 Göztepe - Istanbul	Tel.: +90 21 63 86 95 70 Fax: +90 21 63 86 38 75	www.schneiderelectric.com.tr
Turkmenistan	■ Schneider Electric Turkmenistan Liaison Office	rue Neitralny Turkmenistan 28, off.326/327 74 000 Achgabad	Tel.: +993 12 46 29 52 Fax: +993 12 46 29 52	
Ukraine	■ Schneider Electric	Rue Krechtchalik 2 252601 Kiev	Tel.: +380 44 462 04 25 Fax: +380 44 462 04 24	
United Arab Emirates	■ Schneider Electric Abu Dhabi	PO Box 29580 Office Floor 2/Lulu Street Al Marina Plaza Tower Abu Dhabi	Tel.: +9712 6 339444 Fax: +9712 6 316606	
United Kingdom	■ Schneider Electric Ltd	Braywick House East Windsor Road - Maidenhead Berkshire SL6 1 DN	Tel.: +44 (0)1 628 508 500 Fax: +44 (0)1 628 508 508	www.schneider.co.uk
United States	■ Schneider Electric	North American Division 1415 Roselle Road Palatine - IL 60067	Tel.: +1 847 397 2600 Fax: +1 847 925 7500	www.squared.com
Uruguay	■ Schneider Electric Uruguay S.A.	Gabriela Pereira 3039 Montevideo	Tel.: +59 82 707 2392 Fax: +59 82 709 0713	
Venezuela	■ Schneider Mg SD TE, S.A	Calle 162/ Piso 2 Edificio Centro Cynamid La Urbina, 1070 - 75319 Caracas	Tel.: +58 2 241 13 44 Fax: +58 2 243 60 09	www.schneider-electric.com.ve



Schneider Electric worldwide

Up-dated: 22-03-2002

Viet Nam	■ R.R.O. of Schneider Electric S.A.	Unit 808, 8th Floor Me Linh Point Tower 2 Ngo Duc Ke Street, District 1 Ho Chi Minh City	Tel.: +84 8 829 60 72 Fax: +84 8 829 60 67
Yugoslavia	■ Schneider Electric Yugoslavia Rep. Office	Gracanicka 1 11000 Belgrade	Tel. : +381 11 328 19 47 Fax : +381 11 328 6 52
Zambia	■ Schneider Zambia	Zambia Office c/o Matipi Craft Center Building Plot 1036 - Accra Road PO Box 22792 - Kitwe	Tel.: +260 222 22 52 Fax: +260 222 83 89
Zimbabwe	■ Schneider Electric	Zimbabwe Liaison Office 75A Second Street (corner Livingstone Avenue) Harare	Tel.: +263 4 707 179/180 Fax: +263 4 707 176

For all the other countries, contacts are ensured by the Regional Divisions (see below).

Africa & Middle-East Zone

Arabic Peninsula Region	■ Schneider Electric	Second Industrial City P.O. Box 89249 11682 Riyadh Saudi Arabia	Tel.: +(966) 1 265 15 15 Fax: +(966)1 265 18 60
Middle-East Region	■ Schneider Elektrik A.S.	Sanayi Ve Ticaret A.S. Tütüncü Mehmet Efendi Cad. N°:110 Kat. 1-2 81080 Göztepe-Istanbul Turkey	Tel.: +(90) 2163 86 95 70 Fax: +(90) 21 63 86 38 75 www.schneider-electric.com.tr
North-East Africa Region	■ Schneider Electric Egypt	68, El Tayaran Street Nasr City, 11371 Cairo Egypt	Tel.: +(20) 24 01 01 19 Fax: +(20) 24 01 66 87 www.schneider.com.eg
North-West Africa Region	■ Schneider Electric Maroc	26, rue Ibnou Khalikane Quartier Palmiers 20100 Casablanca Morocco	Tel.: +(212) 299 08 48 à 57 Fax: +(212) 299 08 67 et 69 www.schneider.co.ma
South Africa Region	■ Schneider Electric South Africa (PTY) Ltd	Cnr Bekker & Montrose roads 1685 - Midrand. South Africa	Tel.: +(27) 11 254 6400 Fax: +(27) 11 315 8830 www.schneider-electric.co.za
South Asia Region	■ Schneider Electric India Pvt Ltd.	D-27 South Extension Part II 110 049 New Dehli India	Tel.: +(91) 116 25 76 58 Fax: +(91) 116 25 80 80 www.schneiderelectric.in.com

Asian Zone

Great China	■ Schneider Beijing	Landmark bldg-Room 1801 8 North Dong Sanhuan Rd, Chaoyang District 100004 Beijing China	Tel.: +(86) 10 65 90 69 07 Fax: +(86) 10 65 90 00 13 www.schneider-electric.com.cn
South-East Asia	■ Schneider South East Asia (HQ) Pte Ltd.	460 Alexandra Road #15-01 PSA building 119963 Singapore	Tel.: +(65) 270 23 66 Fax: +(65) 273 46 10

European Zone

ECE-CIS Countries	■ Schneider Electric ZAO	Enisseyskaya 37 129 281 Moscow	Tel.: +7095 797 40 00 Fax: +7095 797 40 03 www.schneider-electric.ru
Nordic countries	■ Schneider Electric A/S	Baltorpbakken 14 DK - 2750 Ballerup Denmark	Tel.: +(45) 44 73 7888 Fax: +(45) 44 68 5255 www.schneider-electric.dk
East Adriatic countries	■ Schneider Electric SA	Fallerovo Setaliste 22 10000 Zagreb Croatia	Tel.: +(385) 1 3667 100 Fax: +(385) 1 3667 111 www.schneider-electric.hr

North-America Zone

■ Schneider Electric North American Division	1415 Roselle Road Palatine IL 60067 USA	Tel.: +(1) 847 397 2600 Fax: +(1) 847 925 7500 www.squared.com
---	---	---

South America & Caribbean Zone

■ Schneider Electric Emp. Partic. Head Office Zone	Avenida Brigadeiro Faria Lima 1478 15° A 01451-913 São Paulo-SP Brazil	Tel.: +(55) 11 816 45 00 Fax: +(55) 11 813 09 43 www.schneider.com.br
---	---	---

Pacific Zone

■ Schneider Electric (Australia) Pty. Limited	2, Solent Circuit Norwest Business Park NSW 2153 Baulkham Hill Australia	Tel.: +(61) 298 51 28 00 Fax: +(61) 296 29 83 10 www.schneider.com.au
--	---	---

Motion control

Community regulations and protective treatment

Community regulations

European Directives

The opening of European markets implies a harmonization of regulations in the various European Union member states. European Directives are documents used to remove obstacles to the free movement of goods and their application is compulsory in all states of the European Union. Member states are obliged to transcribe each Directive into their national legislation and, at the same time, to withdraw any conflicting regulations. The Directives, particularly those of a technical nature with which we are concerned, only set objectives, called "general requirements". The manufacturer must take all necessary measures to ensure that his products conform to the requirements of each Directive relating to his equipment. As a general rule, the manufacturer affirms that his product conforms to the necessary requirements of the Directive(s) by applying the **e** label to his product. **e** marking is applied to Telemecanique products where relevant.

The significance of e marking

e marking on a product means that the manufacturer certifies that his product conforms to the relevant European Directives ; it is necessary in order that a product which is subject to a Directive(s) can be marketed and freely moved within the European Union.

e marking is intended solely for the national authorities responsible for market regulation.

For electrical equipment, only conformity of the product to standards indicates that it is suitable for use, and only a guarantee by a recognised manufacturer can ensure a high level of quality.

One or more Directives, as appropriate, may apply to our products, in particular :

p The Low Voltage Directive 72/23/EEC amended by Directive 93/68/EEC: **e** marking under the terms of this Directive could not be applied before 1 January 1995 and is compulsory as of 1 January 1997.

p The Electromagnetic Compatibility Directive 89/336/EEC, amended by Directives 92/31/EEC and 93/68/EEC: **e** marking on the products covered by this Directive has been compulsory since 1 January 1996.

Protective treatment of equipment

Premium and Quantum PLCs meet the requirements of "TC" treatment (1). For installations in industrial production workshops or in an environment which corresponds to "TH" treatment (2), Premium PLCs should be enclosed in casings with a minimum of IP 54 protection as prescribed by standards IEC 664 and NF C 20 040.

Premium and Quantum PLCs are supplied with an IP 20 protection index. They can therefore be installed without enclosure in locations with restricted access which do not exceed pollution degree 2 (control room which does not contain a machine or dust-producing activity).

(1) "TC" treatment : all climate treatment.

(2) "TH" treatment : treatment for hot and humid environments.

© Copyright Schneider Electric 2003.

All rights reserved. No part of this work may be translated and/or reproduced or copied in any form or by any means - graphic, electronic or mechanical including photocopying, recording, taping or storage in an information retrieval system.

All software quoted in this document is the property of Schneider Automation, or a third party which has granted rights to Schneider Automation. The supply of such software confers a non-exclusive licence on the recipient to use such software solely for the purpose for which it was supplied. Any copying of such software, etc. (except solely for the purpose of producing back-up and security copies) is totally forbidden.

All products, hardware, software and services shown in this document are subject to modification and change without notice. Any descriptions or specifications given herein shall not be capable as being interpreted as part or a condition of any contract relative to such product, software or service.

Twin Line is registered trademark of Berger Lahr GmbH.

TSX is registered trademark of Schneider Automation.

Telemecanique is registered trademark of Schneider Electric.

All other products and brands quoted in this document are registered trademarks of their respective holders.

