

HARMONY XB5R

DISTANCE & PROTOCOL

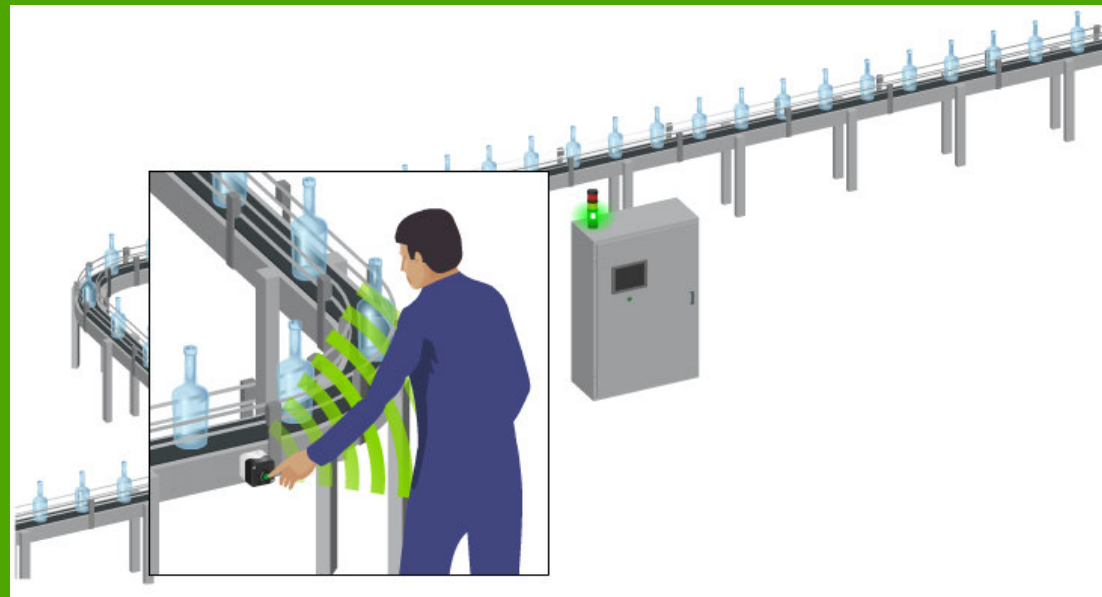

Schneider
Electric

Typical distance transmitter / receiver

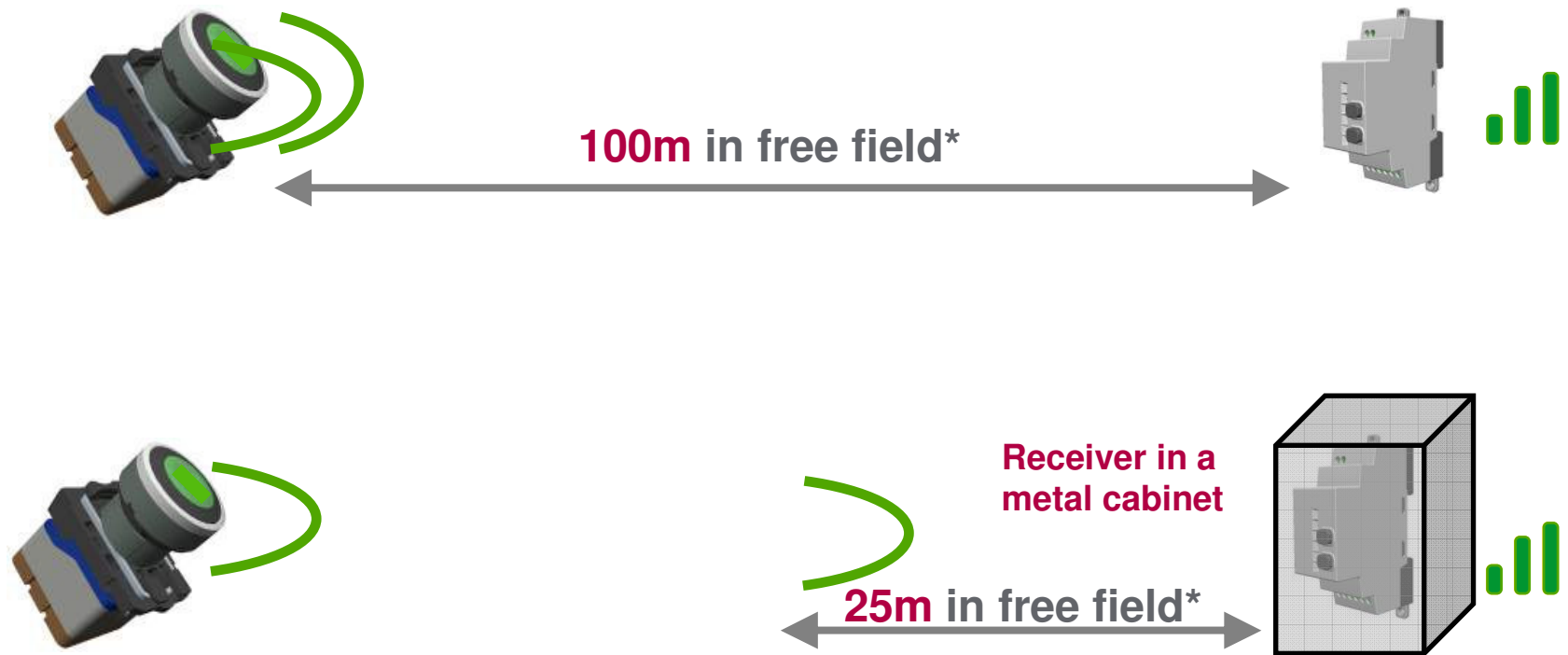

→ The performances are the same whatever the type of receiver.
(* free field (unobstructed and no radio interference))

Typical distance transmitter / receiver PLUS external antenna

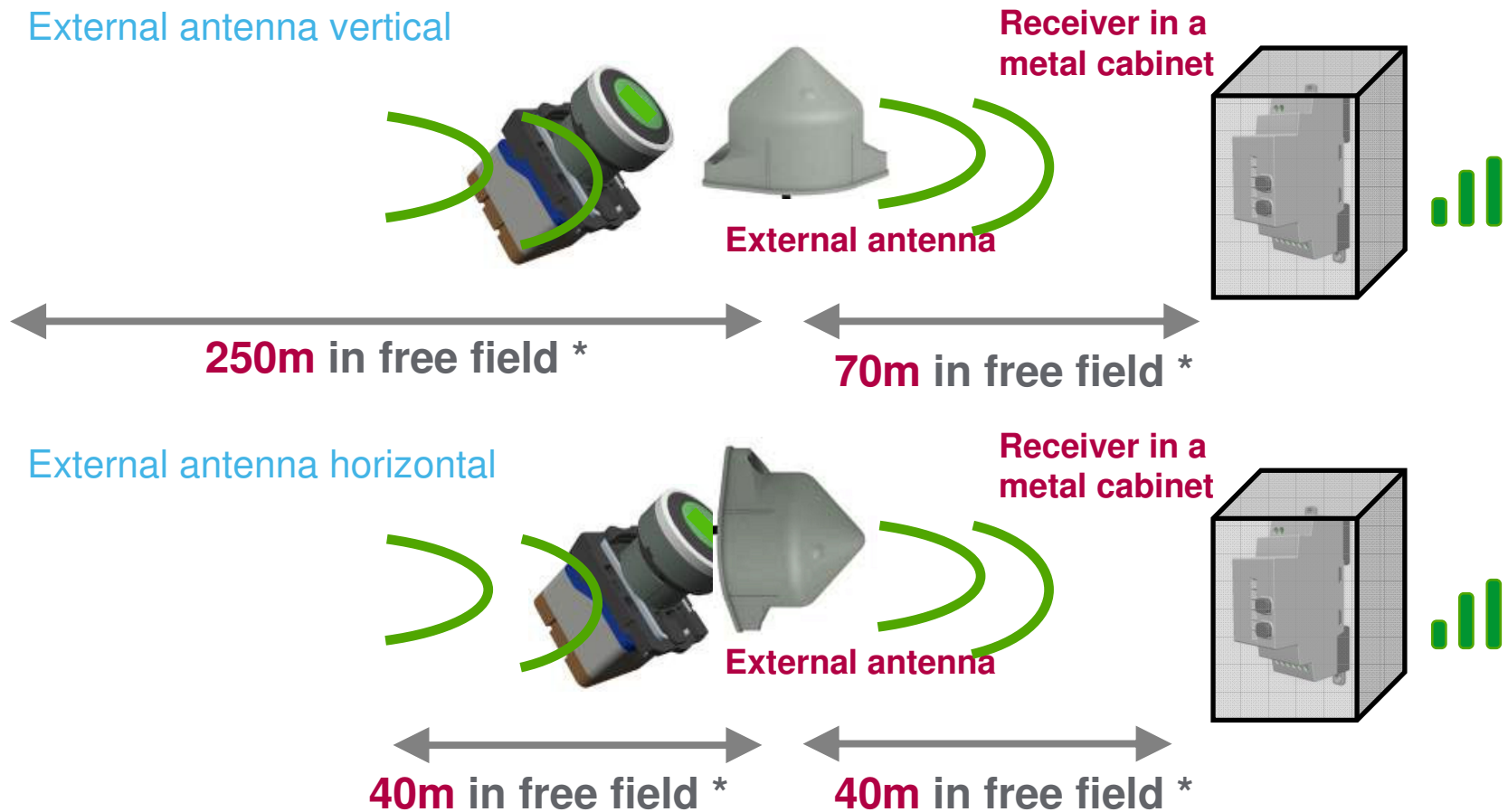

→ The performances are the same whatever the type of receiver.
(*) free field (unobstructed and no radio interference)

Typical distance transmitter / receiver PLUS external antenna

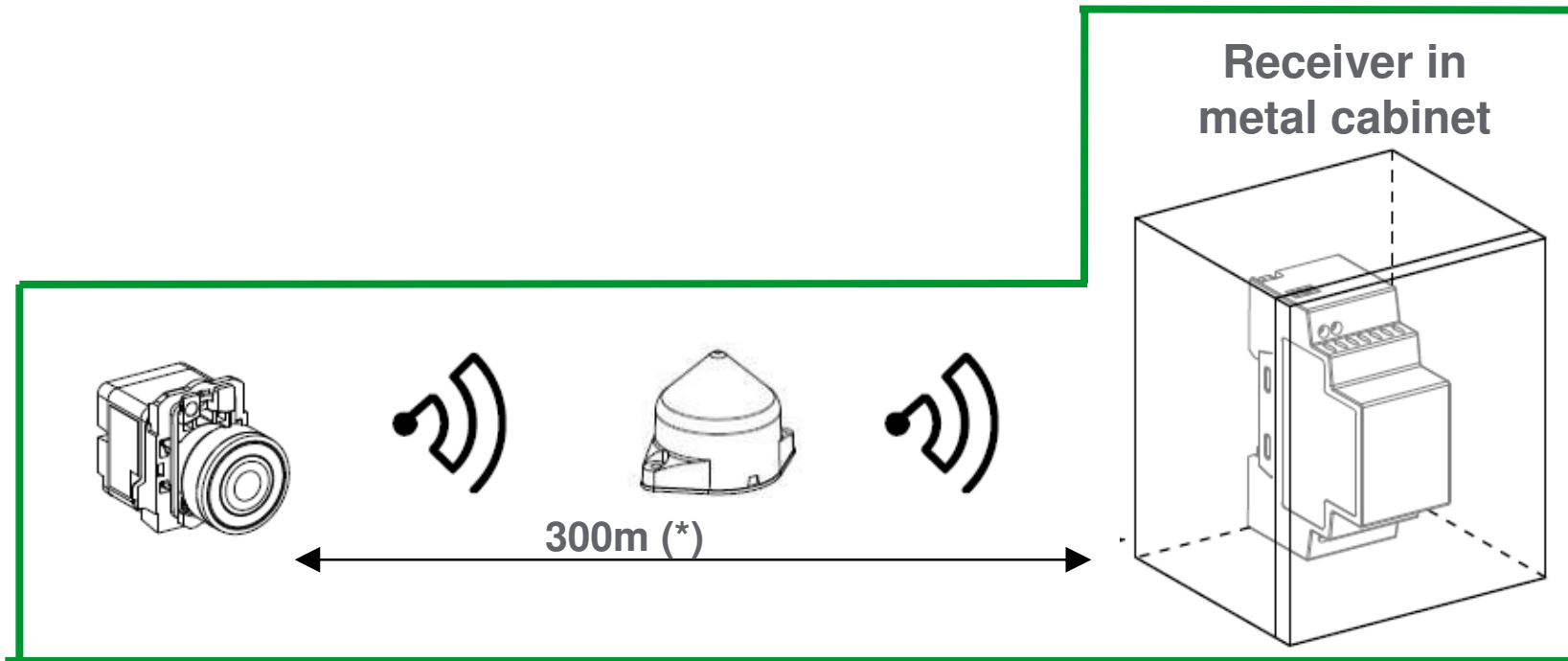

- The antenna is not wired to the receiver or to the transmitter
- The antenna needs only power supply
- The antenna can be installed at the same time than the transmitter and the receiver or later if the transmission must be performed.
- One antenna can be used for one or several receivers / transmitters.

(*) free field (unobstructed and no radio interference)

Radio transmission and obstacles

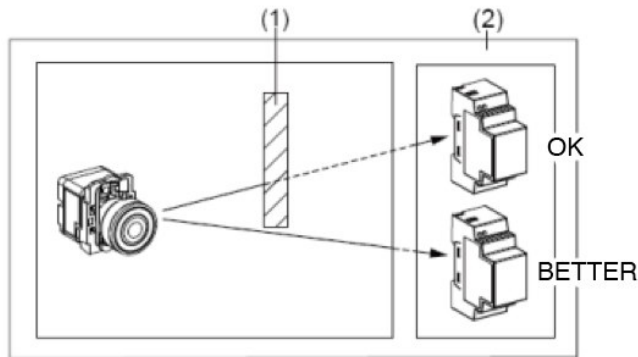

(1) Metal structure (2) wall

Install the transmitter and the receiver in a location with the least amount of obstacles.

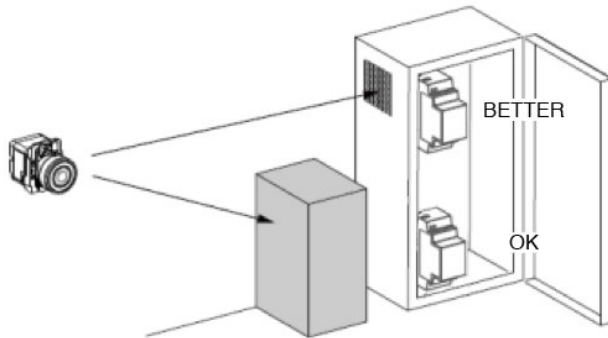

In a metal cabinet the best place for the receiver is on the top and/or near holes of the cabinet. These positions avoid obstacle and enhance transmission

Schneider Electric - Division - Name – Date

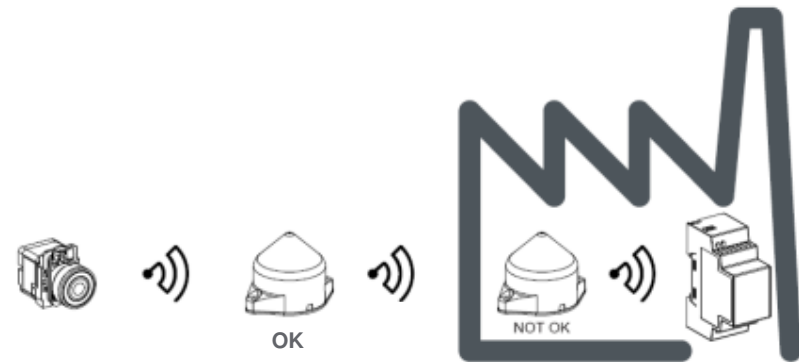

The antenna must be placed before the obstacle. The signal will be strengthened before the obstacle to help the transmission

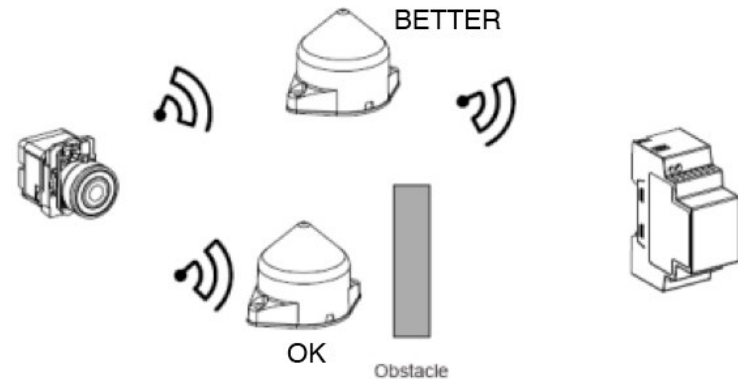

The antenna can be used to bypass the obstacle

How to ensure a reliable transmission anywhere in a workshop

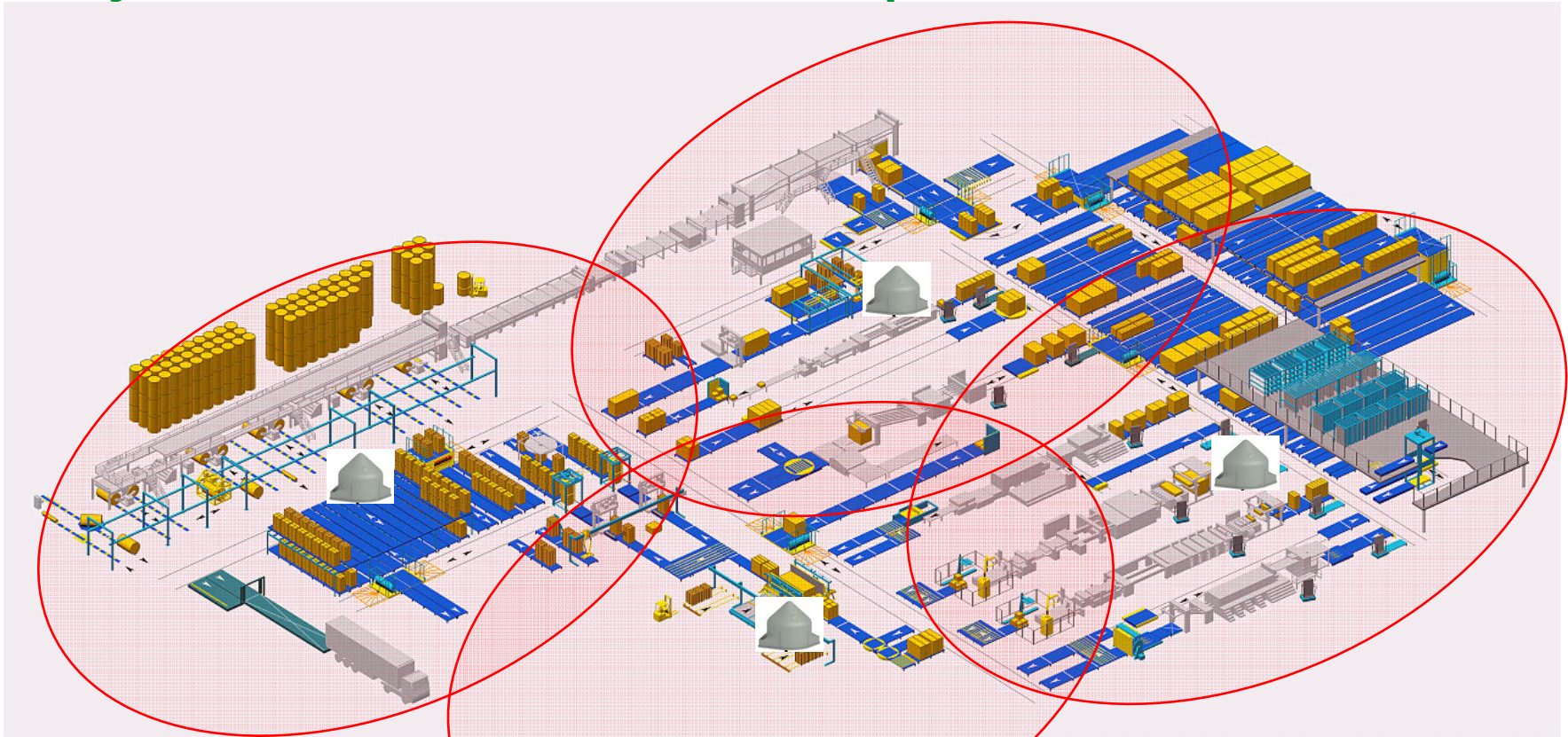

- By installing a set of external antennas in a facility, the radio transmission will operate in all the area
- Benefits: Reliability increased + independent from the changes of location of machines

Possibility to use many external antennas

Example with more than 2 external antennas ZBRA1

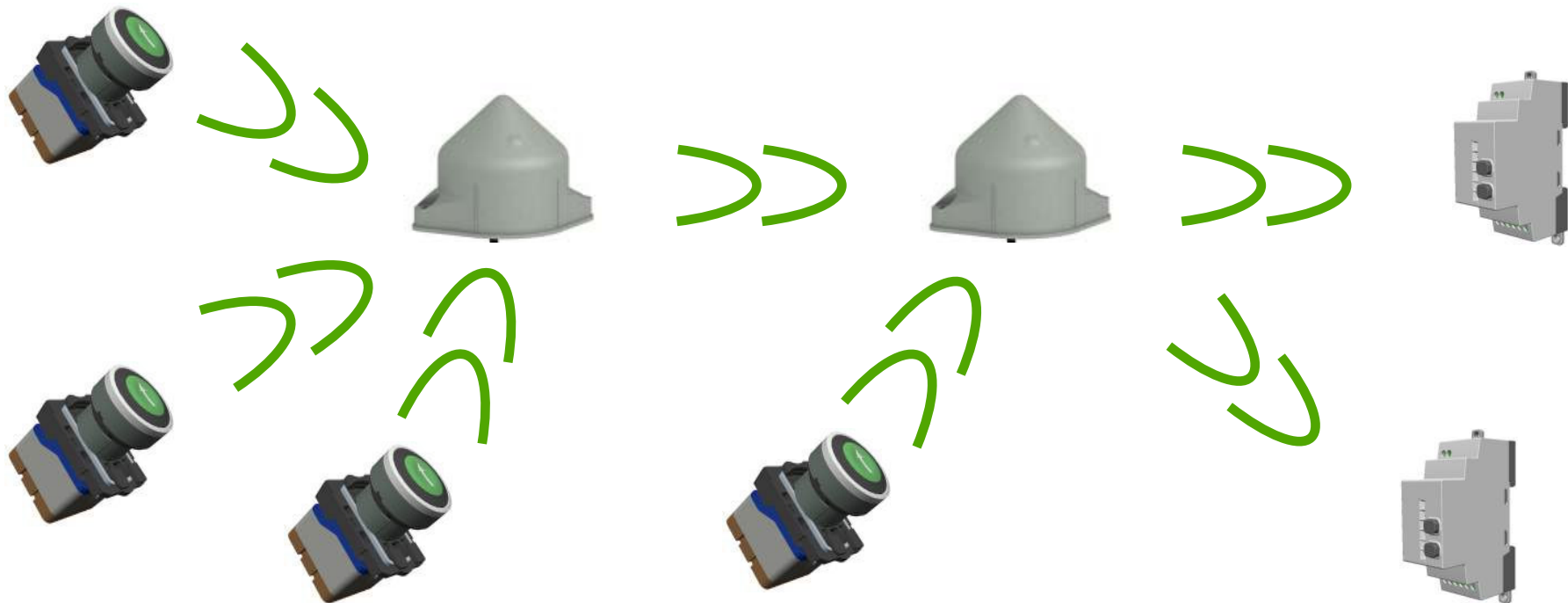

Transmission delay

- Pushbutton → receiver (status change): 20 ms maximum
- Pushbutton → external antenna → receiver (status change) : 74 ms maximum
- Each external antenna needs between 10 to 54ms to resend the message coming from the transmitter

Why XB5R suitable for industrial use



ZigBee[®]
Control your world

- ZigBee is developed by the ZigBee Alliance:

- A consortium of end users and solution providers, primarily responsible for the development of the 802.15.4 standard
- Developing applications and network capability utilizing the 802.15.4 packet delivery mechanism
- Addresses application and interoperability needs of a substantial part of the market including industrial segment



PHILIPS

SONY

SIEMENS



Schneider
Electric

- Data coding system:

- ZigBee relies upon the robust IEEE 802.15.4 PHY/MAC to provide reliable data transfer in noisy, interference rich environments

- 32 millions of different ID numbers for each transmitter:

- One receiver cannot be tripped by a transmitter unless it has been taught before

Why XB5R suitable for industrial use

- Phase Modulation :

- Superior noise and interference rejection, enhanced immunity to signal fading, and reduced susceptibility to nonlinearities in the transmission and receiving systems

- 802.15.4 standard :

- Channel 11 offers the lowest probability to interfere with other frequencies operating within the 2.4 GHz bandwidth

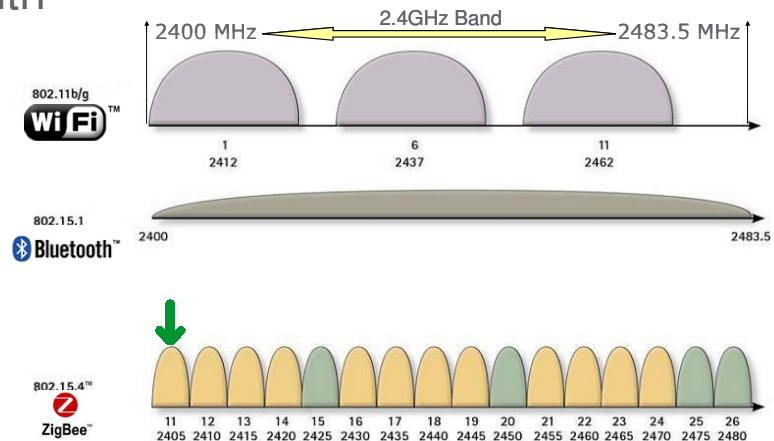

Compliance to industrial standards

- **EC marking (Transmitter -button- , Receiver and Antenna: EN 301 489-1 and EN 301 489-3)**
 - Clause 3.1a (respect of **safety** requirements, of which low voltage directive)
 - human exposure to Radio Frequency fields safety => specific absorption rate (**SAR**) purposeless for Europe because Product emitted power <20mW
 - **low voltage** safety => according to and IEC 60947-1 and IEC 60947-5-1
 - Clause 3.1b (respect of **EMC** requirements)
 - common technical requirements (technical characteristics and test methods): EN 301 489-1
 - specific conditions for Short Range Device (SRD, from 1 to 40 GHz): EN 301 489-3
 - according to IEC 60947-1 and IEC 60947-5-1
 - Clause 3.2 (respect of **RF** requirements)
 - electromagnetic compatibility and radio spectrum, 1 to 40GHz, technical characteristics and test methods: EN 300 440-1
 - electromagnetic compatibility and radio spectrum, 1 to 40GHz, under article 3.2 of R&TTE directive: EN 300 440-2
- **Other certifications**
 - UL 508 standard (industrial control equipment) relating to UL marking requirements
 - CSA C22-2 standard (industrial control apparatus) relating to CSA marking requirements
 - Radio Frequencies:
 - USA: FCC part 15 247
 - Canada: RSS 210
 - Other areas in the world for RF (see certification Department)
- **Type, Class, Category :**
 - EN 301-489-1 - paragraph 5.5 - Equipment for **fixed use**
 - EN 301-489-3 - paragraph 4.1 - Equipment **Type: III** (others)
 - EN 301-489-3 - paragraph 6.1 - Equipment **Class: 2** (Medium reliable SRD)
 - EN 300-440-1 - paragraph 4.1.1 - for Receiver and Antenna: **Reliable category 2** (Medium reliable SRD)
 - EN 300 440-1 - paragraph 5.4.1.2 - **Temperature category I** (General): -20 °C to +55 °C