

# External Brick SPDs

## Square D External Panel Surge Protective Devices

Square D™ brand Surgeloc™ external brick panel Surge Protective Devices (SPDs) deliver specification grade performance for service entrance or critical branch panel applications. This multi-phase surge suppression system provides transient suppression, noise filtration, and sine wave tracking in a durable package.



by Schneider Electric

# External Brick SPDs Features



External brick panel Surge Protective Devices (SPDs) provide superior design and service life for a wide variety of commercial, industrial, or institutional applications. Square D brand Surgelogic SPDs offer unsurpassed performance and surge suppression for demanding service entrance applications or as part of a suppression network. The robust construction minimizes possible down time and helps reduce maintenance costs.

## Superior Performance

Surgelogic brick panel SPDs utilize a high-energy suppression circuit that provides 10 modes of suppression from 120,000 to 240,000 peak amps of surge current rating per phase. Brick panel SPDs contain a suppression circuit that not only provides additional transient surge suppression, but also noise filtration. Optional sine wave tracking delivers increased filtering and clamping.

For harsh environments, stainless steel NEMA 4X rated external modular products provide surge suppression in areas that can damage other enclosures.

## Easy Installation

External panel SPDs mount adjacent to the equipment through a conduit connection and as close to the circuit breaker as possible in order to reduce lead lengths and improve surge suppression.

## Warranty

Surgelogic external brick SPDs have a 10-year warranty.

FEATURES	ADVANTAGES	BENEFITS
NEMA 3R or 4X Rated	Allows installation in outdoor applications	Provides surge suppression to vulnerable equipment powered from weather-exposed panels
120,000 to 240,000 Amp Capacity (depending on model)	Longer service life and suppression against high-energy lightning strikes	High performance surge suppression even in severe electrical conditions
Optional EMI/RFI (sine wave tracking) module	Increased clamping and greater noise filtration.	Improves surge suppression and reduces high frequency noise
Advanced Diagnostics	Allows for online testing of the suppressor's functionality	Provides immediate response if suppressor is damaged
Suppression Status Alarms	Allows multiple methods of alarm notification	Provides immediate notification through audible, visual and remote signaling if reduced suppression occurs
Coordinated Fuse Technology	Coordinated fusing allows disconnection methods for thermal and high-current events	Provides premium surge suppression while managing both thermal and high-current end-of-life events

# External Brick SPDs

## Features (continued)

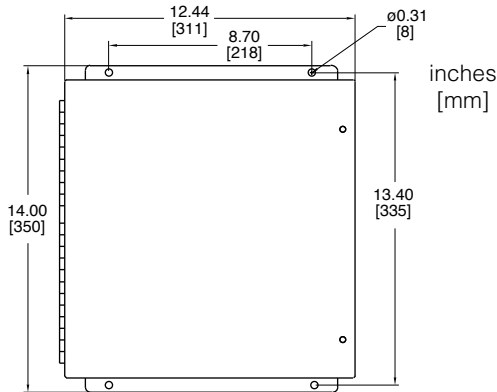

NEMA 3R, Carbon Steel Enclosure  
Weight: 22lbs ± 2lbs

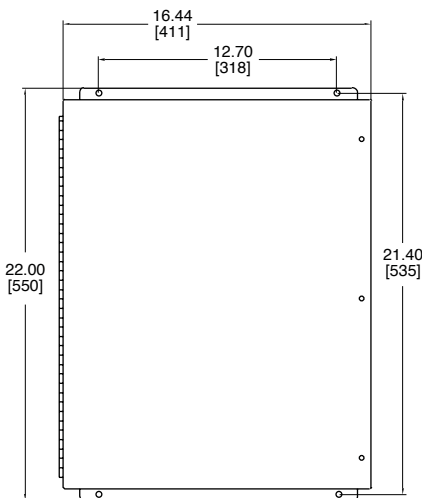

NEMA 3R, Carbon Steel Enclosure with or without  
Integral Switch  
NEMA 4X, Stainless Steel Enclosure with or without  
Integral Switch  
Weight: 31lbs ± 7lbs

## External Brick SPDs

### Performance

Surge Current Rating per Phase	Up to 240kA
Short Circuit Current Rating	200kA
Modes of Protection	10
Fusing	Individually fused MOVs
Thermal Fusing	Yes
Overcurrent Fusing	Yes
EMI/RFI Filtering	-54 dB at 100 kHz*
Operating Frequency	50/60 Hz

### Mechanical Description

Enclosure	Carbon Steel or Stainless Steel
NEMA Ratings	NEMA 3R or 4X
Connection Method	#10-#2 AWG Terminals
Mounting Method/Circuit Type	Parallel
Operating Altitude	Sea Level-12,000' (3,658 m)
Storage Temperature	-40° F (-40° C) to 149° F (65° C)
Operating Temp.	-4° F (-20° C) to 149° F (65° C)
LCD Operating Temp.	32° F (0° C) to 149° F (65° C)
Operating Humidity	0 to 95% non-condensing

### Diagnostics

Push to test diagnostic switches, red and green status LEDs per phase (internal redundant status LEDs are green), module status LEDs per mode, dry contacts, audible alarm with disable switch, surge counter.

### Options

- EMI/RFI filtering (sine wave tracking) module
- NEMA 4X rating with stainless steel enclosure
- Integral Switch
- Flush mount kit (for panel sizes 12"x12"x6" and 16"x2"x6" only)
- Remote monitor

### Listings and Performance

cULus Listed per UL1449 3rd Edition Type 2 SPD,  
UL 1283, CSA C22.2 No. 8-M1986  
Complies with UL 96A 12th Ed. Master Label  
requirements for Lighting Protection Systems

\* with optional sine wave tracking module

# External Brick SPDs Specifications

Voltage	Surge Current per Phase	Modes of Protection	Configuration	Model Number	MCOV	I <sub>n</sub>	VPR			
							L-N	L-G	L-L	N-G
120/240V	120kA	6	1 Ø, 3-wire+G	TVS1EBA12_	150V	20kA	700V	700V	1200V	700V
208Y/120V ■	120kA	10	3 Ø, Wye, 4-wire+G	TVS2EBA12_	150V	20kA	700V	700V	1200V	700V
480Y/277V ▲	120kA	10	3 Ø, Wye, 4-wire+G	TVS4EBA12_	320V	20kA	1200V	1200V	2000V	1200V
600Y/347V	120kA	10	3 Ø, Wye, 4-wire+G	TVS8EBA12_	420V	20kA	1500V	1500V	2500V	1500V
120/240V	160kA	6	1 Ø, 3-wire+G	TVS1EBA16_	150V	20kA	700V	700V	1200V	700V
208Y/120V ■	160kA	10	3 Ø, Wye, 4-wire+G	TVS2EBA16_	150V	20kA	700V	700V	1200V	700V
480Y/277V ▲	160kA	10	3 Ø, Wye, 4-wire+G	TVS4EBA16_	320V	20kA	1200V	1200V	2000V	1200V
600Y/347V	160kA	10	3 Ø, Wye, 4-wire+G	TVS8EBA16_	420V	20kA	1500V	1500V	2500V	1500V
120/240V	240kA	6	1 Ø, 3-wire+G	TVS1EBA24_	150V	20kA	700V	700V	1200V	700V
208Y/120V ■	240kA	10	3 Ø, Wye, 4-wire+G	TVS2EBA24_	150V	20kA	700V	700V	1200V	700V
480Y/277V ▲	240kA	10	3 Ø, Wye, 4-wire+G	TVS4EBA24_	320V	20kA	1200V	1200V	2000V	1200V
600Y/347V	240kA	10	3 Ø, Wye, 4-wire+G	TVS8EBA24_	420V	20kA	1500V	1500V	2500V	1500V

■ 208Y/120 series also applies to the following voltage 220Y/127 ▲ 480Y/277 series also applies to the following voltages 380Y/220, 400Y/230, and 415Y/240

Voltage	Surge Current per Phase	Modes of Protection	Configuration	Model Number	MCOV	I <sub>n</sub>	VPR						
							L-N	H-N	L-G	H-G	L-L	H-L	N-G
240/120HLD	120kA	10	3 Ø, HLD*, 4-wire+G	TVS3EBA12_	150V	20kA	700V	1200V	700V	1000V	1200V	1500V	700V
240/120HLD	160kA	10	3 Ø, HLD*, 4-wire+G	TVS3EBA16_	150V	20kA	700V	1200V	700V	1000V	1200V	1500V	700V
240/120HLD	240kA	10	3 Ø, HLD*, 4-wire+G	TVS3EBA24_	150V	20kA	700V	1200V	700V	1000V	1200V	1500V	700V

\*HLD = High-leg delta

Model numbers not recognized as line items in Schneider Electric ordering system until a suffix code is applied

## MODEL NUMBER SUFFIX CODES

A = NEMA 3R, steel enclosure (e.g. TVS4EBA12A)

ASWT = NEMA 3R, steel enclosure with sine wave tracking module (e.g. TVS4EBA12ASWT)

AI = NEMA 3R, steel enclosure with integral switch (e.g. TVS4EBA12AI)

AISWT = NEMA 3R, steel enclosure with integral switch and sine wave tracking module (e.g. TVS4EBA12AISWT)

S = NEMA 4X, stainless steel enclosure (e.g. TSV4EBA12S)

SSWT = NEMA 4X, stainless steel enclosure with sine wave tracking module (e.g. TSV4EBA12SSWT)

SI = NEMA 4X, stainless steel enclosure with integral switch (e.g. TVS4EBA12SI)

SISWT = NEMA 4X, stainless steel enclosure with integral switch and sine wave tracking module (e.g. TVS4EBA12SISWT)

## SPD ACCESSORIES

Remote Monitor	TVS12RMU
12"x12" Flush Mount Kit	TVS12FMK
16"X20" Flush Mount Kit	TVS20FMK

Square D and Surgelogic are trademarks owned by Schneider Electric Industries SAS or its affiliated companies. All other trademarks are the property of their respective owners.

**Schneider Electric USA, Inc.** 1751 S. 4800 W., Salt Lake City, UT 84104, USA Telephone: (801)-977-9009 Fax: (801)-977-0200 www.surgelogic.com

Document Number 9990-0113C

March 2011 bt

This document provided by Barr-Thorp Electric Co., Inc. 800-473-9123 www.barr-thorp.com