

## 1.1 Contents of SY/MAX Hardware Description

---

### Input Modules

8030 RIM 101  
8030 RIM 121  
8030 RIM 123  
8030 RIM 125  
8030 RIM 126  
8030 RIM 127  
8030 RIM 301  
8030 RIM 331  
8030 RIM 361  
8030 RIM 731

### Output Modules

8030 ROM 121  
8030 ROM 122  
8030 ROM 221/431  
8030 ROM 421  
8030 ROM 431  
8030 ROM 441

### Multiplex Modules

8030 RIM 144  
8030 RIM 144 (Grey)  
8030 ROM 141

### Relay Modules

8030 ROM 271  
8030 ROM 871

### Remote I/O Modules

8030 CRM 931 DG1  
8030 CRM 931 DG2  
8030 CRM 931 DG4  
8030 CRM 931 DG8

### Miscellaneous Modules

8030 CRM 931 RG  
8030 RIM 131  
8030 ROM 131  
8030 SIM 116

## 1.2 8030 CRM 931 RG

---

The CRM931 Remote I/O (RIO) adapter module provides a communication interface between a Quantum processor and remote SY/MAX I/O on a RIO network. The interface provides a means for the processor to read and write to the input and output of the Sy/Max I/O modules.

### 1.2.1 Specifications

#### Electrical

Current draw on SY/Max Power supply	750 mA (typical). 900 mA (maximum)
Under voltage lockout circuit	Halts and resets the module and removes it from the RIO network when the incoming DC supply voltage falls below approximately 4.6 VDC.

#### Functional

Input Registers	64
Output Registers	64

#### RIO Drop Switches

SW1 (top) and SW2 (bottom) Drop Address Settings

Drop Address	SW2 (tens)	SW1 (ones)
1 - 9	0	1 - 9
10 - 19	1	0 - 9
20 - 29	2	0 - 9
30 - 32	3	0 - 2



Note If a "0" or > 32 address is selected, the RIO drop module displays a flashing Comm Error LED to indicate an error condition. Although a 1 address is valid for the 984 it may be invalid for other modules.

## 1.3 8030 CRM 931 DG8

---

The CRM931 Remote I/O (RIO) adapter module provides a communication interface between a Quantum processor and remote SY/MAX I/O on a RIO network. The interface provides a means for the processor to read and write to the input and output of the Sy/Max I/O modules.

### 1.3.1 Specifications

#### Electrical

Current draw on SY/Max Power supply	750 mA (typical). 900 mA (maximum)
Under voltage lockout circuit	Halts and resets the module and removes it from the RIO network when the incoming DC supply voltage falls below approximately 4.6 VDC.

#### Functional

Input Registers	64
Output Registers	64

#### RIO Drop Switches

##### SW1 (top) and SW2 (bottom) Drop Address Settings

Drop Address	SW2 (tens)	SW1 (ones)
1 - 9	0	1 - 9
10 - 19	1	0 - 9
20 - 29	2	0 - 9
30 - 32	3	0 - 2



Note If a "0" or > 32 address is selected, the RIO drop module displays a flashing Comm Error LED to indicate an error condition. Although a 1 address is valid for the 984 it may be invalid on other modules.

## 1.4 8030 CRM 931 DG4

---

The CRM931 Remote I/O (RIO) adapter module provides a communication interface between a Quantum processor and remote SY/MAX I/O on a RIO network. The interface provides a means for the processor to read and write to the input and output of the Sy/Max I/O modules.

### 1.4.1 Specifications

#### Electrical

Current draw on SY/Max Power supply	750 mA (typical). 900 mA (maximum)
Under voltage lockout circuit	Halts and resets the module and removes it from the RIO network when the incoming DC supply voltage falls below approximately 4.6 VDC.

#### Functional

Input Registers	64
Output Registers	64

#### RIO Drop Switches

##### SW1 (top) and SW2 (bottom) Drop Address Settings

Drop Address	SW2 (tens)	SW1 (ones)
1 - 9	0	1 - 9
10 - 19	1	0 - 9
20 - 29	2	0 - 9
30 - 32	3	0 - 2



Note If a "0" or > 32 address is selected, the RIO drop module displays a flashing Comm Error LED to indicate an error condition. Although a 1 address is valid for the 984 it may be invalid on other modules.

## 1.5 8030 CRM 931 DG2

---

The CRM931 Remote I/O (RIO) adapter module provides a communication interface between a Quantum processor and remote SY/MAX I/O on a RIO network. The interface provides a means for the processor to read and write to the input and output of the Sy/Max I/O modules.

### 1.5.1 Specifications

#### Electrical

Current draw on SY/Max Power supply	750 mA (typical). 900 mA (maximum)
Under voltage lockout circuit	Halts and resets the module and removes it from the RIO network when the incoming DC supply voltage falls below approximately 4.6 VDC.

#### Functional

Input Registers	64
Output Registers	64

#### RIO Drop Switches

SW1 (top) and SW2 (bottom) Drop Address Settings

Drop Address	SW2 (tens)	SW1 (ones)
1 - 9	0	1 - 9
10 - 19	1	0 - 9
20 - 29	2	0 - 9
30 - 32	3	0 - 2



Note If a "0" or > 32 address is selected, the RIO drop module displays a flashing Comm Error LED to indicate an error condition. Although a 1 address is valid for the 984 it may be invalid on other modules.

## 1.6 8030 CRM 931 DG1

---

The CRM931 Remote I/O (RIO) adapter module provides a communication interface between a Quantum processor and remote SY/MAX I/O on a RIO network. The interface provides a means for the processor to read and write to the input and output of the Sy/Max I/O modules.

### 1.6.1 Specifications

#### Electrical

Current draw on SY/Max Power supply	750 mA (typical). 900 mA (maximum)
Under voltage lockout circuit	Halts and resets the module and removes it from the RIO network when the incoming DC supply voltage falls below approximately 4.6 VDC.

#### Functional

Input Registers	64
Output Registers	64

#### RIO Drop Switches

##### SW1 (top) and SW2 (bottom) Drop Address Settings

Drop Address	SW2 (tens)	SW1 (ones)
1 - 9	0	1 - 9
10 - 19	1	0 - 9
20 - 29	2	0 - 9
30 - 32	3	0 - 2



Note If a "0" or > 32 address is selected, the RIO drop module displays a flashing Comm Error LED to indicate an error condition. Although a 1 address is valid for the 984 it may be invalid on other modules.

## 1.7 8030 RIM 101/361

---

For the specification on the 361 module click [HERE](#).

Class 8030 Type RIM-101 16 Function 120 VAC/DC Input Module.

Input 1	—	01
Input 2	—	02
Input 3	—	03
Input 4	—	04
L2	—	1A
Input 5	—	05
Input 6	—	06
Input 7	—	07
Input 8	—	08
L2	—	2A
Input 9	—	09
Input 10	—	10
Input 11	—	11
Input 12	—	12
L2	—	3A
Input 13	—	13
Input 14	—	14
Input 15	—	15
Input 16	—	16
L2	—	4A

### 1.7.1 Specifications

Module Topology

Inputs per Module	16
Type of Isolation	Optical
Isolation Rating	2500 V RMS
Voltage Operating Range	90-132 VAC (50/60Hz) or VDC
Input Current Draw	6 mA at 90 V and 10 mA at 138 V
Must Turn On Voltage	90 V
Must Turn On Current	6 mA (at 90 V)
Must Turn Off Voltage	30 V
Must Turn Off Current	2 mA (at 25 V)
Input Impedance	14.4K OHMS Resistive
Turn On Time	8 ms Nominal
Turn Off Time	8 ms Nominal
Rated Current Draw on Sy/Max Power Supply	300 mA at 100% Duty Cycle
Ambient Temperature Rating	0-60 C
Humidity Rating	5-95 % non-condensing
Detachable Terminal Block	Class 8030 Type CBP-116



## 1.8 8030 RIM 121/125

---

For the specification on the 125 module click [HERE](#).

Class 8030 Type RIM-121 Standard Analog Module.

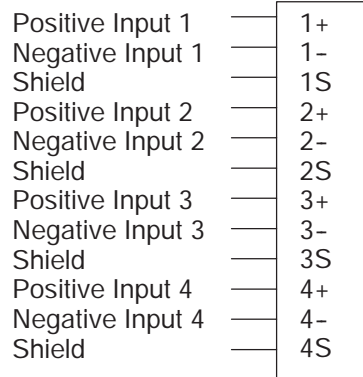

### 1.8.1 Specifications

Module Topology

Inputs per Module	4 Single ended (the selected range applies)
Ranges	1-5 VDC, 0-10 VDC, +10 to -10 VDC, 4-20 mA.
Accuracy	Plus or minus 0.1% at 25C, plus or minus 0.5% (of full scale) over 0-60C temperature range
Resolution	1 part in 2,000 (full scale range in the storage register of 0-9995, in increments of 5)
Under-Range Indication	Converted to 0000
Over-Range Indication	Converted to 9999
Live Zero	(Open circuit detection) converted to -1 (applicable to 4-20 mA range only)
Conversion Rate	5 conversions per channel per sec. (all 4 channels are updated every 200 milliseconds) Note: 50 msec. response can be obtained for a single channel (1) if selected per Section 3.3 (4-20 mA only) the remaining channels cannot be used.
Isolation	200V channel to ground (or analog input circuit to digital logic circuit) continuously applied. 1500V transient isolation.
Maximum Input Overload	34 mA (current), plus or minus 50 VDC (voltage), applied continuously to the input terminals.
Current Loop Resistors	250 ohms plus or minus .01%, 5 PPM/deg C (resident in module)
Power Requirement	1400 mA current draw from Sy/Max power supply connected to the rack.
Input Impedance	.082 uF in parallel with 5M ohms (voltage) or 250 ohms (current)
Common-Mode Rejection Ratio	84 dB
Run Light	Indicates digital logic circuitry is functioning properly.
Ambient Temperature Rating	0-60 C
Humidity Rating	5-95% relative humidity (non-condensing)
Detachable Terminal Block	Class 8030 Type CBP-110

### Dip Switch Settings

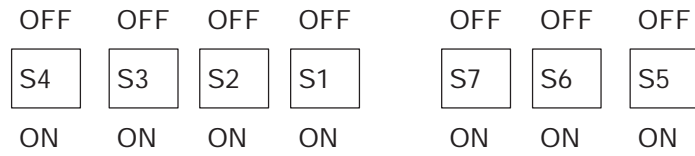

X = ON  
O = OFF

User Range	S1 to S4	S5	S6	S7
Single Channel	X	X	0	0
1 to 5 Volts	0	X	X	0
0 to 10 Volts	0	0	X	X
-10 tp +10 Volts	0	0	0	X
4 to 20 mA	X	X	X	0

## 1.9 8030 RIM 123

---

Class 8030 Type RIM-123 High-Speed Analog Input Module.

Positive Input 1	—	1+
Negative Input 1	—	1-
Shield	—	1S
Positive Input 2	—	2+
Negative Input 2	—	2-
Shield	—	2S
Positive Input 3	—	3+
Negative Input 3	—	3-
Shield	—	3S
Positive Input 4	—	4+
Negative Input 4	—	4-
Shield	—	4S
Positive Input 5	—	5+
Negative Input 5	—	5-
Shield	—	5S
Positive Input 6	—	6+
Negative Input 6	—	6-
Shield	—	6S
Positive Input 7	—	7+
Negative Input 7	—	7-
Shield	—	7S
Positive Input 8	—	8+
Negative Input 8	—	8-
Shield	—	8S

### 1.9.1 Specifications

Module Topology

Inputs per Module	8 differential inputs. (Selected range applies to all)
Ranges	0-5 VDC, 1-5 VDC, 0-10 VDC, +/-5 VDC, +/-10 VDC, 4-20 mA.
Accuracy	Plus or minus 0.05% at 25C plus or -0.25% (of full scale) over 0-60C temperature range
Resolution	13.5 bits, 1 part in 10,000 (full scale range in the storage register of 0-9999, in increments of 1)
Worst Case Conversion Rate	2 ms for all 8 channels with input averaging= 1.
Under-Range Indication input	Converted to -0001 for 1-5V range and 4-20 mA input range at signals less than 0.9 VDC and 3.6 mA respectively. Under-range inputs for all other unipolar and bipolar ranges are converted to 0001.
Over-Range Indication	Converted to 10,000
Open Circuit Indication	Open circuits converted to -0001 in current mode only.
Isolation	300V channel to ground (or analog input circuit to digital logic circuit) continuously applied. 1500VAC for 1 min.
Common-Mode Range	For proper operation, input voltage plus common-mode voltage must be less than +/-15 VDC.
Maximum Input Overload	30 mA (current loop input), 50 VDC (voltage input), applied continuously to the input terminals.
Current Loop Resistors	250 ohms plus or minus 0.025%, 25 PPM/deg C (resident in module)
Power Requirement	875 mA current draw from Sy/Max power supply connected to the rack.
Input Impedance Differential input: Common- mode input:	Current input: 250 Ohms 10,000,000,000,000 Ohms 10,000,000,000,000 Ohms
Calibration	Auto-Calibrated
Common-Mode Rejection Ratio(CMR)	84 dB DC to 60 Hz at 1K ohm source imbalance.
Run Light	Indicates digital logic circuitry is functioning properly.
Ambient Temperature Rating	0-60 C
Humidity Rating	5-95% relative humidity (non-condensing)
Terminal Block	Square D part number 30617-215-50

Dip Switch Settings  
Input Range Selection.

Input Range	Dip Switch Positions		
	SW2-1	SW2-2	SW2-3
+/-10 VDC	OPEN	OPEN	OPEN
+/-5 VDC	CLOSED	OPEN	OPEN
0-10 VDC	OPEN	CLOSED	OPEN
0-5 VDC	CLOSED	CLOSED	OPEN
1-5 VDC	OPEN	OPEN	CLOSED
4-20 mA	CLOSED	OPEN	CLOSED
INVALID*	OPEN CLOSED	CLOSED CLOSED	CLOSED CLOSED

\* INVALID switch settings default to +/-10 VDC input range and loads 61H into the status/error register

### Sample Rate Selection

Number of Samples	Dip Switch Positions	
	SW2-4	SW2-5
1	OPEN	OPEN
4	CLOSED	OPEN
8	OPEN	CLOSED
32	CLOSED	CLOSED

 Note Dip switch SW2, positions 6, 7, and 8 are not currently used.

### Channel Enable/Inhibit Control Selection.

SW1-1=Channel 1  
 SW1-2=Channel 2  
 SW1-3=Channel 3  
 SW1-4=Channel 4  
 SW1-5=Channel 5  
 SW1-6=Channel 6  
 SW1-7=Channel 7  
 SW1-8=Channel 8

Channel Enable =OPEN/OFF (0)  
 Channel Inhibit =CLOSED/ON (1)

 Note Any unused analog input channels should be set up as channel inhibited to reduce the total module conversion time. If a channel is inhibited, its register will contain the value '-32768'.

### Voltage/Current Input Selection

SW3-1=Channel 1  
SW3-2=Channel 2  
SW3-3=Channel 3  
SW3-4=Channel 4  
SW3-5=Channel 5  
SW3-6=Channel 6  
SW3-7=Channel 7  
SW3-8=Channel 8

Voltage Input =OPEN/OFF  
Current Input =CLOSED/ON

## 1.10 8030 RIM 125

---

Class 8030 Type RIM-125 16 Channel Analog Input Module.

Input 1	1
Common	1C
Input 2	2
Common	2C
Input 3	3
Common	3C
Input 4	4
Common	4C
Input 5	5
Common	5C
Input 6	6
Common	6C
Input 7	7
Common	7C
Input 8	8
Common	8C
Not Used	X1
Not Used	X2
Input 9	9
Common	9C
Input 10	10
Common	10C
Input 11	11
Common	11C
Input 12	12
Common	12C
Input 13	13
Common	13C
Input 14	14
Common	14C
Input 15	15
Common	15C
Input 16	16
Common	16C
Not Used	X3
Not Used	X4

### 1.10.1 Specifications

Module Topology

16 SY/MAX Remote I/O



Inputs per Module	16 (two range groups-user definable)
Ranges	0-5 VDC, 1-5 VDC, 0-10 VDC, +5 to -5 VDC +10 to -10 VDC, 0-20 mA, 4-20 mA.
Accuracy	Plus or minus 0.05% (of full scale) at 25C, plus or minus 0.25% over 0-60C temperature range.
Resolution	13.5 bits, 1 part in 10,000 (full scale range in the storage register of 0-9998, in increments of 1)
Under-Range Indication	Converted to -0001 for the 1-5 VDC and 4-20 mA inputs at signals less than 0.9 VDC and 3.6 mA respectively. All other unipolar and bipolar voltage ranges are converted to 0000.
Over-Range Indication	Converted to 9999
Conversion Rate	180 milliseconds for all 16 channels, 60 milli- seconds for 4 channels.
Isolation	300V channel to ground (or analog input circuit to digital logic circuit) continuously applied. 1500V transient isolation.
Maximum Input Overload	30 mA (current), 50 VDC (voltage), applied continuously to the input terminals.
Current Loop Resistors	250 ohms plus or minus 0.025%, 25 PPM/deg C (resident in module)
Power Requirement	800 mA current draw from Sy/Max power sup- ply connected to the rack.
Input Impedance	0.1 uF in parallel with 100M ohms (voltage) or 250 ohms (current)
Common-Mode Rejection Ratio	84 dB
Run Light	Indicates digital logic circuitry is functioning properly.
Ambient Temperature Rating	0-60 C
Humidity Rating	5-95% relative humidity (non-condensing)

### Dip Switch Settings Switch Selection Procedure

1. Select group border if desired (SW2, 1-4)
2. Select ranges for each group (SW1, 1-8)
3. Select voltage/current switch for each channel (SW3, 1-8 and SW4, 1-8)
4. Select number of samples for each group (SW2, 5-8)

### Dip Switch 1

Group 1					Group 2				
Switch Range	1-1	1-2	1-3	1-4	Switch Range	1-5	1-6	1-7	1-8
Not Used	ON	ON	ON	X	Not Used	ON	ON	ON	X
0-5V	OFF	ON	ON	X	0-5V	OFF	ON	ON	X
0-20mA	OFF	ON	ON	X	0-20mA	OFF	ON	ON	X
0-10V	ON	OFF	ON	X	0-10V	ON	OFF	ON	X
1-5V	OFF	OFF	ON	X	1-5V	OFF	OFF	ON	X
4-20mA	OFF	OFF	ON	X	4-20mA	OFF	OFF	ON	X
+/-5V	ON	ON	OFF	X	+/-5V	ON	ON	OFF	X
+/-10V	OFF	ON	OFF	X	+/-10V	OFF	ON	OFF	X

X=Don't Care

### Dip Switch 2

Switch Border	2-1	2-2	2-3	2-4
1	ON	ON	ON	ON
2	OFF	ON	ON	ON
3	ON	OFF	ON	ON
4	OFF	OFF	ON	ON
5	ON	ON	OFF	ON
6	OFF	ON	OFF	ON
7	ON	OFF	OFF	ON
8	OFF	OFF	OFF	ON
9	ON	ON	ON	OFF
10	OFF	ON	ON	OFF
11	ON	OFF	ON	OFF
12	OFF	OFF	ON	OFF
13	ON	ON	OFF	OFF
14	OFF	ON	OFF	OFF
15	ON	OFF	OFF	OFF
16	OFF	OFF	OFF	OFF

Group 1			Group 2		
No. of Samples	Switch		No. of Samples	Switch	
	2-5	2-6		2-7	2-8
1	ON	ON	1	ON	ON
4	OFF	ON	4	OFF	ON
8	ON	OFF	8	ON	OFF
32	OFF	OFF	32	OFF	OFF

### Switch 3

Channel	1	2	3	4	5	6	7	8
Switch	3-1	3-2	3-3	3-4	3-5	3-6	3-7	3-8
Current	ON	ON	ON	ON	ON	ON	ON	ON
Voltage	OFF	OFF	OFF	OFF	OFF	OFF	OFF	OFF

### Switch 4

Channel	9	10	11	12	13	14	15	16
Switch	4-1	4-2	4-3	4-4	4-5	4-6	4-7	4-8
Current	ON	ON	ON	ON	ON	ON	ON	ON
Voltage	OFF	OFF	OFF	OFF	OFF	OFF	OFF	OFF

## 1.11 8030 RIM 126

---

Class 8030 Type RIM-126 8 Channel Isolated Analog Input Module.

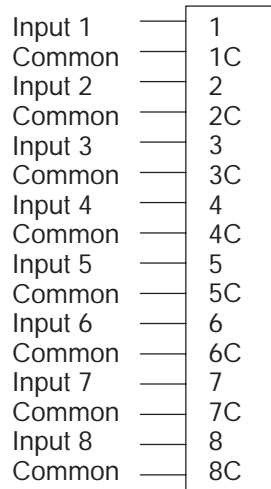

### 1.11.1 Specifications

#### Module Topology

Inputs per Module	8 (two range groups-user definable)
Registers Required for Rack Addressing	12
User-Definable Function Group	Two independent input function groups, each with its own range and number of inputs, can be created per module.
High-Level Ranges	Seven: 0-5 VDC, 1-5 VDC, 0-10 VDC +/- 5 VDC, +/- 10 VDC, 0-20 mA, 4-20 mA.
Low-Level Ranges	Nine: +/- 50 mVDC, and thermocouple types J,K,T,E,B,R,S,C. Thermocouple

## Operation Ranges (Full Scale)

Type	Temp. Range F	Temp. Range C
J	-50 to +1400	-40 to +760
K	-100 to +2250	-80 to +1240
T	-200 to +660	-130 to +350
E	-200 to +1250	-130 to +680
R	0 to +3200	-20 to +1760
S	0 to +3200	-20 to +1760
B	+500 to +3200	+260 to +1760
C	0 to +4200	-20 to +2320

## Resolution

Resolution (VDC, mA, mVDC)	Five parts in 10,000 (full scale range)
Resolution (Thermocouple J,K,E,T)	0.5 degree (C and F)
Resolution (thermocouple R,S,B,C)	0.4 degree (C and F)

## Thermocouple Accuracy and Repeatability

Type/Range	Accuracy % of full scale				Repeatability % of full scale
	Fast Update		High Accuracy Update*		
	20C	0-60C	20C	0-60C	
J	0.3%	0.4%	0.3%	0.4%	0.1%
K	0.25%	0.3%	0.25%	0.3%	0.1%
T	0.5%	0.6%	0.5%	0.6%	0.2%
E	0.3%	0.4%	0.3%	0.4%	0.15%
R	0.5%	0.75%	0.5%	0.75%	0.15%
S	0.4%	0.5%	0.4%	0.5%	0.15%
B**	0.5%	0.5%	0.5%	0.5%	0.15%
C	0.4%	0.5%	0.4%	0.5%	0.15%
mV	0.2%	0.2%	0.1%	0.15%	0.05%
V	0.4%	0.5%	0.1%	0.15%	0.05%

\* The "HIGH ACCURACY" mode affects only the mV, current and V ranges

\*\* Type B thermocouple accuracy is +/- 2.0% below 1500F (815C). Above this temperature the figures in the table above apply.



Note The accuracies in the above table relates strictly to the RIM-126. The accuracy of thermocouples varies greatly and should be taken into account when used with this module

Calibration	Automatic
Under-Range Indication (VDC, mA, mVDC)	Converted to -1 for the 1-5VDC and 4-20 mA inputs at signals less than 0.9 VDC and 3.6 mA respectively. All other unipolar and bipolar voltage ranges are converted to 0.
Under-Range Indication (Thermocouple)	Provided in RIM-126 register number 10; bits 1 through 8 turn ON for channels 1 through 8 respectively.
Over-Range Indication (VDC, mA, mVDC)	Converted to 9999. Use greater than or equal to in programming comparison rungs.
Over-Range Indication (Thermocouple)	Provided in RIM-126 register number 10; bits 9 through 16 turn ON for channels 1 through 8 respectively.
Open Input Detection, (Thermocouple)	Provided in RIM-126 register number 9; bits 1 through 8 turn ON for channels 1 through 8 respectively.
Update Time Fast Mode	12 msec for all 8 high-level input channels, 260 msec for all 8 thermocouple input channels.
Update Time High Accuracy Mode	24 msec for all 8 high-level input channels, 285 msec for all 8 thermocouple input channels.
Input Isolation	750 V channel-to-channel and channel to ground (or analog circuit to digital logic circuit) continuously applied. 1500V transient isolation.
Maximum Input Overload	Current range: 30 mA (continuous) Voltage and Thermocouple range: 50 VDC (continuous)
Overvoltage Protection	Clamping diode
Current Loop Resistors	250 Ohm +/- 0.05%, 25 PPM/deg. C (resident in the module)
Power Requirement	1250 mA current draw from Sy/Max power supply connected to the rack.
Input Impedance	Hi-Level Voltage 1 Megohm Hi-Level Current 250 Ohms Low-Level/Thermocouple 100 Megohm
Common-Mode Rejection Ratio	110 dB
Run Light	Indicates digital logic circuitry is functioning properly.
Ambient Temperature Rating	0-60 C
Humidity Rating	5-95% relative humidity (non-condensing)

### 1.11.2 Dip Switch Settings

#### Channel Range Selection

SW1 through SW8 are used to select the gain, current, and voltage ranges for input channels 1 through 8 respectively.

Range Desired	Positions on SW1 through SW8 (1=ON, 0=OFF)					
	1	2	3	4	5	6
+/- 50 mVDC	0	1	0	0	1	1
All thermocouples	0	1	0	0	1	1
Not Used	0	0	1	1	1	0
0-5 VDC	0	0	1	0	1	0
0-20 mA	0	0	1	1	1	0
1-5 VDC	0	0	1	0	1	0
4-20 mA	0	0	1	1	1	0
+/- 5 VDC	0	0	1	0	1	0
0-10 VDC	1	0	1	0	1	0
+/- 10 VDC	1	0	1	0	1	0

#### Function Group Range Selection

The eight channels of the RIM-126 can be divided into two distinct analog functions groups. Each function group assumes the analog range (0-5 VDC, 4-

20 mA, Type T, etc.) assigned it by SW9, assuming that the channel range selection dip switches are correctly set.

Range Desired	Positions on SW9 (1=ON, 0=OFF)							
	Group 1				Group 2			
	1	2	3	4	5	6	7	8
Not Used	1	1	1	1	1	1	1	1
Type J	0	1	1	1	0	1	1	1
Type K	1	0	1	1	1	0	1	1
Type T	0	0	1	1	0	0	1	1
Type E	1	1	0	1	1	1	0	1
Type R	0	1	0	1	0	1	0	1
Type S	1	0	0	1	1	0	0	1
Type C	1	1	1	0	1	1	1	0
+/- 50 mVDC	0	1	1	0	0	1	1	0
0-5 VDC	1	0	1	0	1	0	1	0
0-20 mA	1	0	1	0	1	0	1	0
0-10 VDC	0	0	1	0	0	0	1	0
1-5 VDC	1	1	0	0	1	1	0	0
4-20 mA	1	1	0	0	1	1	0	0
+/- 5 VDC	0	1	0	0	0	1	0	0
+/- 10 VDC	1	0	0	0	1	0	0	0



Note 4-20 mA and 1-5 VDC ranges can be mixed within a single function group since their function group switch positions are identical.

#### Border Selection

Positions 1-3 of dip switch SW10 are used to separate function group 1 inputs from function group 2 inputs. Group 1 starts with channel 1 and ends with the channel that is selected by SW10.

Function Group 1 End with Channel:	Position on SW10 (1=ON, 0=OFF)		
	1	2	3
1	1	1	1
2	0	1	1
3	1	0	1
4	0	0	1
5	1	1	0
6	0	1	0
7	1	0	0
8 (No Group 2)	0	0	0



### Temperature Readings Selection

Position 4 of dip switch SW10 selects either deg. C or deg. F for thermocouple temperature ranges.

For deg. C SW10 position 4 is ON

for deg. F SW10 position 4 is OFF

### Sample Selection

Positions 5-8 of dip switch SW10 are used to select software averaging of the input signals on function groups 1 and 2. Positions 5 and 6 are used for group 1, while positions 7 and 8 are used for group 2.

Number of Samples	Position on SW10 (1=ON, 0=OFF)			
	5	6	7	8
1	1	1	1	1
4	0	1	0	1
8	1	0	1	0
32	0	0	0	0

### Alternate Scan Selection

The RIM-126 normally scans channels 1-8 sequentially, starting with channel 1. To accommodate high speed requirements, channel 1 can be updated by the module after every other channel update.

Position 1 of dip switch SW11 activates the channel 1 priority feature.



Note This feature does not apply to the thermocouple ranges.

For channel 1 priority, position 1 of SW11 is ON.

For normal scan, position 1 of SW11 is OFF.

The Alternate Scan Selection changes the channel update time as follows:

Channel 1 will be updated every 7 msec

Channels 2-8 will be updated every 16 msec

### Update Rate Selection

The RIM-126 has two update rates available, Fast mode and High Accuracy mode. The Fast mode updates eight high-level inputs once every 12 ms and eight thermocouples inputs every 260 ms. The High Accuracy mode updates eight high-level inputs every 24 ms and eight thermocouples every 285 ms.

Position 2 of dip switch SW11 selects the update rate:  
For the Fast mode, position 2 of SW11 is OFF.  
For the High Accuracy mode, position 2 of SW11 is ON.



Note The update rate selection effects both function groups.

The remainder of SW11 is unused.

## 1.12 8030 RIM 127

Class 8030 Type RIM-127 12 Channel RTD/Direct Resistance Input Module.

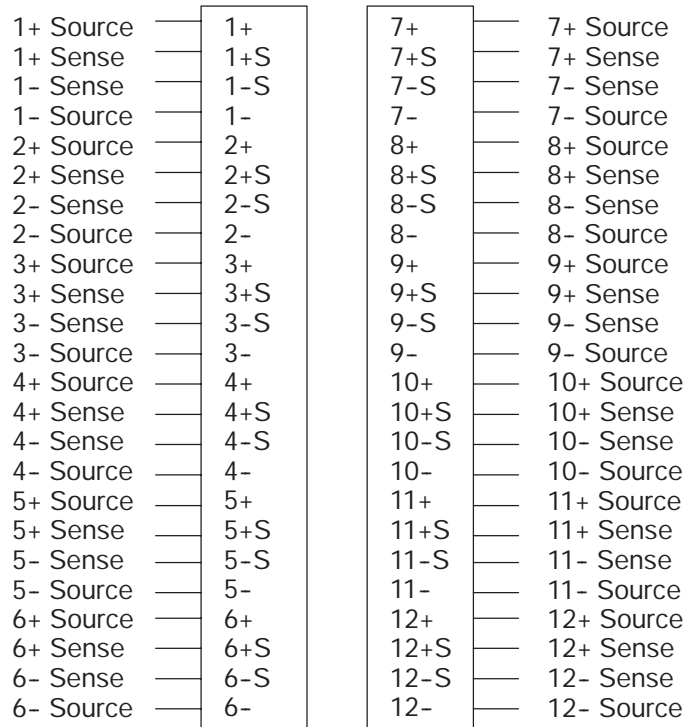

### 1.12.1 Specifications

#### Module Topology

Inputs per Module	12
Registers Required for Rack Addressing	16
User-Definable Function Groups	Two independent input function groups can be created per module, each with its own range, RTD wire type, software averaging samples and number of inputs.
Ranges (RTD)	Nineteen Ranges including: (alpha 3850, 3911, and 3926) 100, 200, 500, 1000 and 2000 Ohm Platinum, (alpha 6720)-120 and 600 Ohm Nickel, (alpha 5188) 604 Ohm Nickel/Iron and (alpha 4274)-10 Ohm Copper.

Ranges (Ohms)	Five Ranges including: 15, 250, 1250, 2500 and 5000 Ohms.
Accuracy	120 Ohm nickel and all platinum RTD ranges except 500 Ohm: 0.1% of full scale at 25 deg. C All direct resistance ranges except 1250 and 15 Ohm: 0.1% of full scale at 25 deg. C 500 Ohm platinum RTD, 600 Ohm nickel RTD, 604 Ohm nickel-Iron RTD and 1250 Ohm resistance: 0.15% of full scale at 25 deg. C All ranges including 10 Ohm copper RTD and 15 Ohm resistance: 0.5% of full scale over 0-60 deg. C
Resolution	RTD: In deg. C or F 0.1% full scale 5 parts in 10,000. Direct Resistance: 0-15 Ohms 0.01% 0-250 Ohms 0.1% 0-1250 Ohms 0.1% 0-2500 Ohms 1.0% 0-5000 Ohms 1.0% full scale 5 parts in 10,000
Calibration	Automatic
Open Circuit Detection	Bits 1-12 of on-board register 15 turn "ON" during an open circuit condition for input channels 1-12 respectively
Over/Under Range Indication	Bits 1-12 of on-board register 16 turn "ON" to indicate under and over range for input channels 1-12 respectively
Invalid EEPROM	Bit 15 of register 15 turns "ON" when EEPROM is invalid
Invalid Range Selection	Bits 13 and 14 of on-board register 15 turn "ON" for groups 1 and 2, respectively, when an invalid range is selected.
Worst Case Update Time	Less than 500 milliseconds for all twelve channels.
Isolation	300V AC/DC channel to ground (or analog circuit ground to Sy/Max digital logic circuit ground) continuously applied. 1500V peak transient isolation.
Power Requirement	1,000 mA current draw from the Sy/Max power supply connected to the rack.
Input Channel Excitation Current	1.5 mA (nominal)
Common Mode Rejection Ratio	84dB (at 60Hz)
Run Light	Indicates digital logic circuitry functioning properly.
Ambient Temperature Rating	0-60 C
Humidity Rating	5-95% relative humidity (non-condensing)

## 1.12.2 Module Configuration

### Function Group Border Selection (Register 14, Bits 1-4)

Function Group 1 Border Selection	Register 14			
	Bit 4	Bit 3	Bit 2	Bit 1
Channel 1	1	0	1	1
Channel 2	1	0	1	0
Channel 3	1	0	0	1
Channel 4	1	0	0	0
Channel 5	0	1	1	1
Channel 6	0	1	1	0
Channel 7	0	1	0	1
Channel 8	0	1	0	0
Channel 9	0	0	1	1
Channel 10	0	0	1	0
Channel 11	0	0	0	1
Channel 12	0	0	0	0

0=OFF, 1=ON



Note The unused bit patterns of 1100, 1101, 1110 and 1111 will cause the border selection to be set to channel 1.

Group Range Selection  
(Register 13)

Range	Function Group 2 Register 13 Data Bits								Function Group 1 Register 13 Data Bits							
	16	15	14	13	12	11	10	9	8	7	6	5	4	3	2	1
Platinum 100 Ohm alpha 3850	0	0	0	0	0	0	T	W	0	0	0	0	0	0	T	W
Platinum 200 Ohm alpha 3850	0	0	0	0	0	1	T	W	0	0	0	0	0	1	T	W
Platinum 500 Ohm alpha 3850	0	0	0	0	1	0	T	W	0	0	0	0	1	0	T	W
Platinum 1000 Ohm alpha3850	0	0	0	0	1	1	T	W	0	0	0	0	1	1	T	W
Platinum 2000 Ohm alpha3850	0	0	0	1	0	0	T	W	0	0	0	1	0	0	T	W
Platinum 100 Ohm alpha 3911	0	0	1	0	0	0	T	W	0	0	1	0	0	0	T	W
Platinum 200 Ohm alpha 3911	0	0	1	0	0	1	T	W	0	0	1	0	0	1	T	W
Platinum 500 Ohm alpha 3911	0	0	1	0	1	0	T	W	0	0	1	0	1	0	T	W
Platinum 1000 Ohm alpha 3911	0	0	1	0	1	1	T	W	0	0	1	0	1	1	T	W
Platinum 2000 Ohm alpha 3911	0	0	1	1	0	0	T	W	0	0	1	1	0	0	T	W
Platinum 100 Ohm alpha 3926	0	1	0	0	0	0	T	W	0	1	0	0	0	0	T	W
Platinum 200 Ohm alpha 3926	0	1	0	0	0	1	T	W	0	1	0	0	0	1	T	W
Platinum 500 Ohm alpha 3926	0	1	0	0	1	0	T	W	0	1	0	0	1	0	T	W
Platinum 1000 Ohm alpha 3926	0	1	0	0	1	1	T	W	0	1	0	0	1	1	T	W
Platinum 2000 Ohm alpha 3926	0	1	0	1	0	0	T	W	0	1	0	1	0	0	T	W
Nickel 120 Ohm alpha 6720	0	1	1	0	0	0	T	W	0	1	1	0	0	0	T	W
Nickel 600 Ohm alpha 6720	0	1	1	0	1	0	T	W	0	1	1	0	1	0	T	W
Copper 10 Ohm alpha 4274	1	0	0	0	0	0	T	W	1	0	0	0	0	0	T	W
Nickel/Iron 604 Ohm alp. 5188	1	0	1	0	1	0	T	W	1	0	1	0	1	0	T	W

Range

	16	15	14	13	12	11	10	9	8	7	6	5	4	3	2	1
Direct Ohm Reading 15 Ohm	1	1	1	0	0	0	0	W	1	1	1	0	0	0	0	W
Direct Ohm Reading 250 Ohm	1	1	1	0	1	0	0	W	1	1	1	0	1	0	0	W
Direct Ohm Reading 1250 Ohm	1	1	1	0	1	1	0	W	1	1	1	0	1	1	0	W
Direct Ohm Reading 2500 Ohm	1	1	1	1	0	0	0	W	1	1	1	1	0	0	0	W
Direct Ohm Reading 500 Ohm	1	1	1	1	0	1	0	W	1	1	1	1	0	1	0	W

Not Used	1	1	1	1	1	1	1	1	1	1	1	1	1	1	1	1
----------	---	---	---	---	---	---	---	---	---	---	---	---	---	---	---	---

0=OFF

1=ON

W=Bits numbered 1 and 9 for function groups 1 and 2 respectively:

OFF= 2 and 4 wire RTD's, and ON= 3 wire RTD's

T=Bits numbered 2 and 10 for function groups 1 and 2 respectively:

OFF= Read in deg. F and ON= Read in deg. C

### Software Averaging Selection (Register 14, Bits 5-8)

Number of Samples	Group 2		Group 1	
	Bit 8	Bit 7	Bit 6	Bit 5
1	0	0	0	0
4	0	1	0	1
8	1	0	1	0
32	1	1	1	1

### Percent of Full-Scale (Register 14, Bits 9-10)

Data Register Output	Group 2 Bit 10	Group 1 Bit 9
Engineering Units (Shown in Ohms, or degrees C or F)	0	0
Percentage of full Scale (Shown as 0000 to 9999 in increments of 5)	1	1



Note Register 14, Bits 11-16 are not used.

### Module Status (Register 15 and 16)

SY/MAX Remote I/O 31

Register	Bits															
	16	15	14	13	12	11	10	9	8	7	6	5	4	3	2	1
15	U	E	V	V	I	I	I	I	I	I	I	I	I	I	I	I
16	U	U	U	U	R	R	R	R	R	R	R	R	R	R	R	R

E= EEPROM Status (OFF during normal operation)  
 V= Valid Range Selected (OFF during normal operation)  
 I= Open Input Detection (OFF during normal operation)  
 R= Over/Under Range (OFF during normal operation)  
 U=Unused



## 1.13 8030 RIM 131

Class 8030 Type RIM-131 High Speed Counter Module.

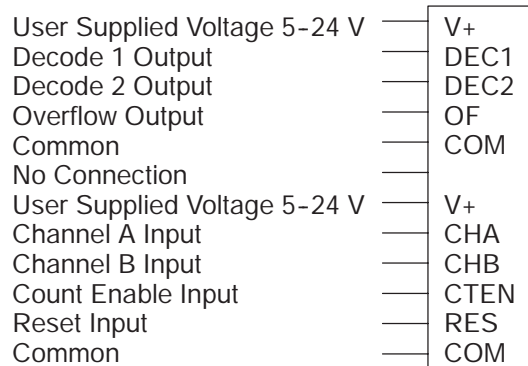

### 1.13.1 Specifications

#### Module Topology

#### LED Description

Number	LED Label	Color	Function
1	Count Enable	Green	Illuminated when count is enabled unless counter is overflowed.
2	Reset	Red	Illuminated when the reset Input has been energized.
3	Decode 1	Red	Illuminated when Decode 1 Output is energized.
4	Decode 2	Red	Illuminated when Decode 2 Output is energized.
5	Overflow	Red	Illuminated when data overflows or underflows.
6	Data Error	Red	Illuminated when processor has furnished bad data during Decode 1, Decode 2, or preset down-load.
7	Module Error	Red	Illuminated when the module self-diagnostics has detected an error.

Sy/Max Register Usage	16
Inputs per module	4
Type and rated isolation between input terminal and logic	Optical, 2000 VRMS

Parameters	Logic 0	Logic 1
Signal	Low	High
User current sink required (per input)	16mA	N.A.
User current source required (per input)	N.A.	0*
User supply voltage required	5 to 24 VDC	

\*Cable capacitance may require some current source

All inputs share a common ground.

Input signals must be 0 to 100 KHz square waves. The minimum time between state changes is five micro-seconds (50% duty cycle at 100 KHz). Notice that input devices must be current sinking.

Outputs per module	3
Type and rated isolation between output terminal and logic	Optical, 2000 VRMS

Parameters	Logic 0	Logic 1
Decode	True	False
Signal from processor	Off	On
Output Voltage	5-24 VDC	0
Module current Sink Capability	250 mA	N.A.
Module current Source Capability	N.A.	0
Leakage current	N.A.	1.0 mA at V= 5-24 VDC
User supply voltage	5 to 24 VDC	

All outputs share a common ground

Rated Current Draw on Sy/Max Power Supply	1200 mA
Ambient Temperature Rating	0-60 C
Humidity Rating	5-95% non-condensing

### 1.13.2 DIP Switch Description

Switch Number	"ON" Function
1	See Mode Table
2	See Mode Table
3	Debounce for Channel A Input
4	Debounce for Channel B Input
5	Debounce for Count Enable Input
6	Debounce for Reset Input
7	Upon energization of the Reset Input, load preset value
8	Not used

#### Mode Table

Mode	Switch 1	Switch 2
Rotary Pulse (quadrature)	off	off
A=Count; B=Direction	off	on
A=Up Count; B=Down Count	on	on
Illegal Mode-Do Not Use	on	off

### 1.13.3 Register Details

The following table details the use of the 16 HSCM registers.

Register 1: Read Only (HSCM to CPU)

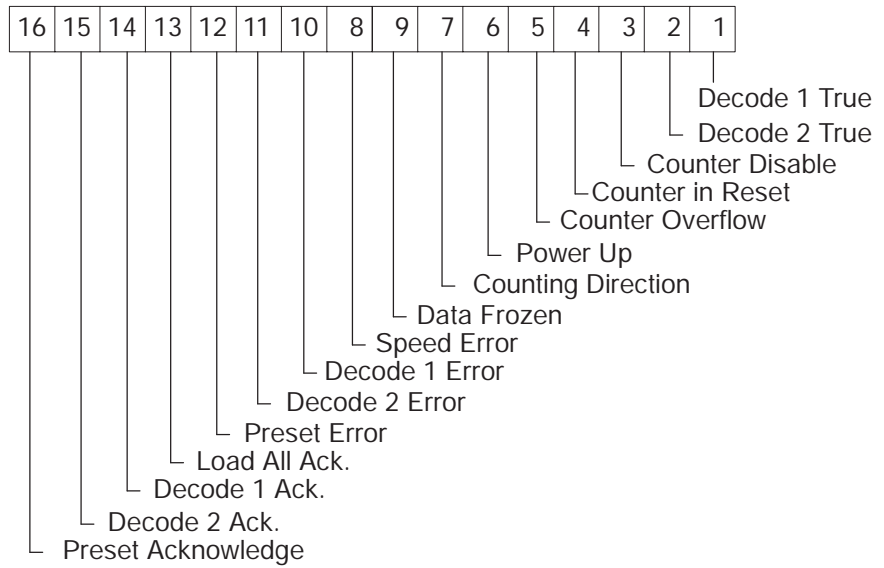

Register 2: (CPU to HSCM Control Word 1)

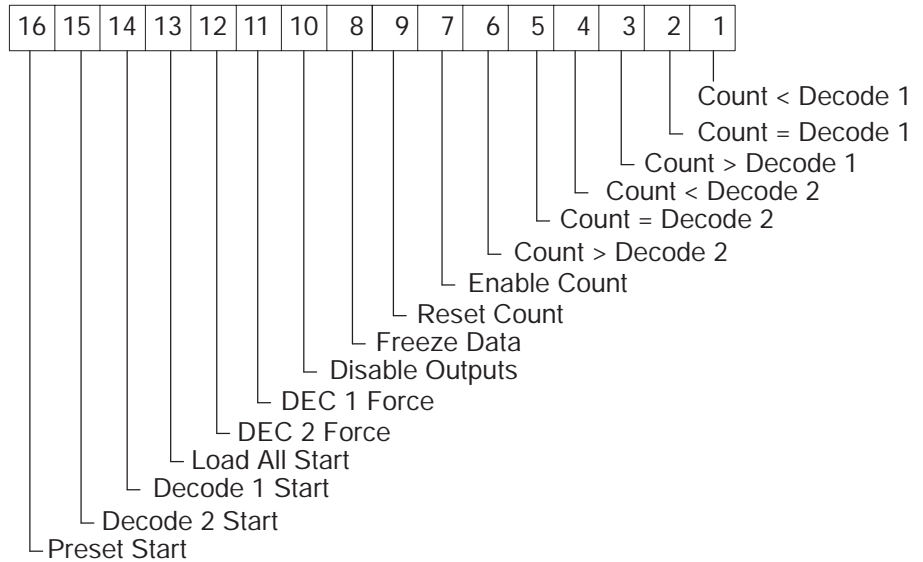

Register 3: Least Significant 4 Digits of Decode 1 Set Point

Register 4: Most Significant 3 Digits of Decode 1 Set Point

Register 5: Least Significant 4 Digits of Decode 2 Set Point

Register 6: Most Significant 3 Digits of Decode 2 Set Point

Register 7: Least Significant 4 Digits of Preset Count Value

Register 8: Most Significant 3 Digits of Preset Count Value

Register 9: (CPU to HSCM Control Word 2)

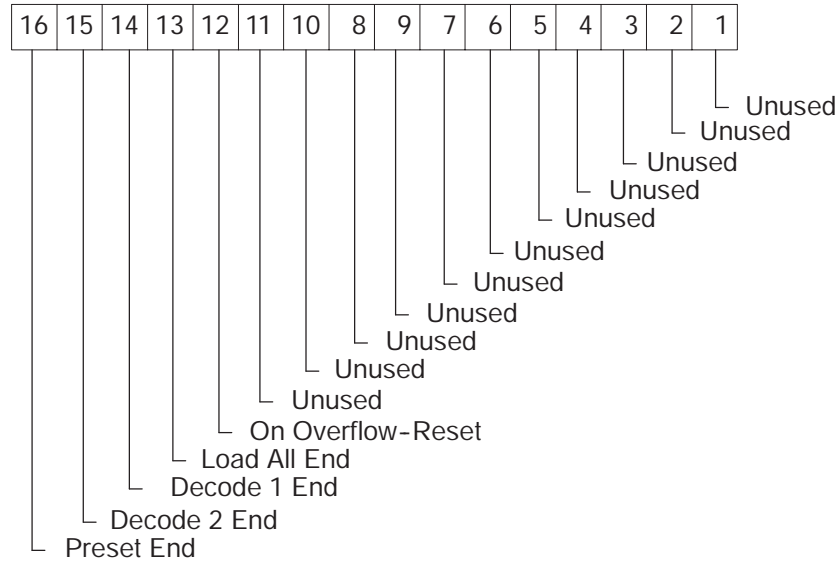

Register 10: Least Significant 4 Digits of Count Value

Register 11: Most Significant 3 Digits of Count Value

Register 12: Count Rate, Pulses Per Second

Register 13: Spare

Register 14: Spare

Register 15: Spare

Register 16: Spare

## 1.14 8030 RIM 144

---

For the specification on the 144 with Gray code click [HERE](#).

Class 8030 Type RIM-144 Multiplexed BCD and Single Channel Fast Response BCD Input Module.

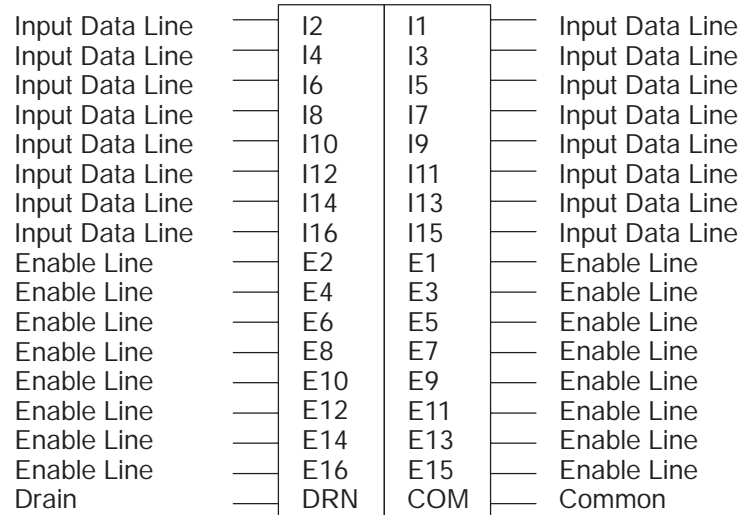

### 1.14.1 Specifications

Module Topology Multiplexed Mode

Register Addresses Used	16 Maximum
Register Slots Required	1
Maximum Thumbwheel Sets per Module	16
Maximum Digits per Thumbwheel Set	4
Types of BCD Thumbwheels Allowed	4 digit maximum (0-9999) diode isolated Nines Complement of BCD.
Recommended Diode	Fairchild 1N457A (Square D Part No. 27906-10800).
Field Wiring Connector Capacity	8, 24 AWG wires per terminal
Maximum Cable Distance Between Module and Thumbwheel Switches	200 ft/60m
Maximum Module Drive Current per Thumbwheel Contact Point	5 mA
Operating Voltage Range	0-12 VDC
Short Circuit Protection	Yes, between Data and Enable lines and ground.
User Power Supply Required	None
Thumbwheel Input Logic Levels (Measured at Module Terminals)	Logic 1: 1.5 VDC Max Logic 0: 10 VDC Min. Thumbwheel
Scan Frequency	8 Hz fixed (125 msec. per scan) for 16 thumbwheel sets
Enable Output Logic Levels (Measured at Module Terminals)	Logic 1: 1.5 VDC Max. Logic 0: 10 VDC Min.
LED Operation Indication	Red ERROR LED lights when improper BCD data is present or upon BCD Input Module malfunction.
Rated Current Draw on Sy/Max Power Supply	750 mA max. (7777 selected on all 16 thumbwheel sets)
Ambient Temperature Rating	0-60 C
Humidity Rating	5-95% non-condensing

## 1.14.2 Dip Switch Setting

12 VDC

Multiplexed Mode  
(Standard Response)

Fast Response Mode  
(non-multiplexed)

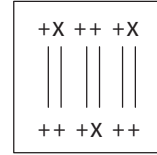
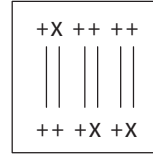
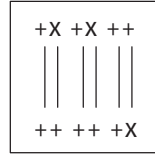
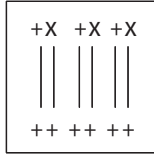

5 VDC

BCD Thumbwheel

9's Compliment

BCD Input

Gray Code Input

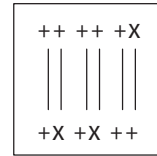
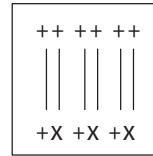
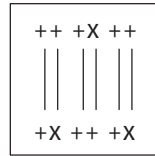
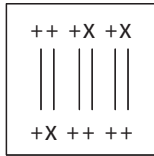

X=Indicates Switch is DEPRESSED on this side.



Note The switches are set to the Fast Response mode when shipped from the factory.

## 1.14.3 Specifications

Module Topology Single Channel Fast Response Mode



Register Addresses Used	2 Maximum
Register Slots Required	1
Maximum BCD Digits	4
Field Wiring Connector Capacity	8, 24AWG wires per terminal
Maximum Cable Distance Between Module and BCD Device	200 ft/60m
Operating Voltage Range	0-5 VDC
Short Circuit Protection	Yes, between Data and Enable lines and ground.
User Power Supply Required	Yes, for BCD device (Resolver to Digital Decoder). No external power supply is required for module operation.
Data Line Input Logic Levels	Logic 1: Sink 1uA max. at 3.5 VDC min. Logic 0: Source 2.5 mA max. at 1.5 VDC
Enable Output Logic Levels	Logic 1: Source 250uA max. at 4.0 VDC min. Logic 0: Sink 300 mA max. at 1.5 VDC max.
Enable Line Handshake Frequency	1818Hz The module reads the data at twice this frequency.
LED Operation Indication	Red ERROR LED lights when improper BCD data is present or upon BCD Input Module malfunction.
Rated Current Draw on Sy/Max Power Supply	625 mA max.
Ambient Temperature Rating	0-60 C
Humidity Rating	5-95% non-condensing

## 1.15 8030 RIM 144 (Grey)

### 1.15.1 Specifications

#### Module Topology Gray Code Mode

Register Addresses Used	3 Maximum
Register Slots Required	1
Maximum Gray Code Digits	16
Field Wiring Connector Capacity	8, 24AWG wires per terminal
Maximum Cable Distance Between Module and Gray Code Device	500 ft/152m using Digisolver with 8-30 VDC option.
Operating Voltage Range	0-5 VDC or 0-12 VDC
Short Circuit Protection	Yes, between Data and Enable lines and ground.
User Power Supply Required	Gray Code device requires its own supply. In the case of Digisolver, set its supply voltage to 20-30 VDC.

#### Data Line Input Logic Levels

Operating Voltage	Logic 1 Sink (min. current)	Logic 0 Source (max. current)
12VDC	1uA at 10VDC	6.2mA at 3.0VDC
5VDC	1uA at 3.5VDC	2.5mA at 1.5VDC

#### Enable Output Logic Levels

Operating Voltage	Logic 1 Source (min. current)	Logic 0 Sink (max. current)
12VDC	50uA at 10VDC	300mA at 1.5VDC
5VDC	50uA at 4.0VDC	300mA at 1.5VDC

Enable Line Handshake Frequency	2300Hz for 9 bit gray code
LED Operation Indication	Lights when improper gray code is present, or if RIM-144 malfunctions. A slight flickering is normal for asynch operation.
Rated Current Draw on Sy/Max Power Supply	625 mA max.
Ambient Temperature Rating	0-60 C
Humidity Rating	5-95% non-condensing

## 1.16 8030 RIM 301

---

Class 8030 Type RIM-301 16 Function 85-140 VAC Input Module.

Please contact Technical Support for this information.

## 1.17 8030 RIM 331

---

Class 8030 Type RIM-331 24V DC 32 Function Input Module.

Negative	1A
Input 1	01
Input 2	02
Input 3	03
Input 4	04
Input 5	05
Input 6	06
Input 7	07
Input 8	08
Negative	2A
Input 9	09
Input 10	10
Input 11	11
Input 12	12
Input 13	13
Input 14	14
Input 15	15
Input 16	16

Negative	3A
Input 17	01
Input 18	02
Input 19	03
Input 20	04
Input 21	05
Input 22	06
Input 23	07
Input 24	08
Negative	4A
Input 25	09
Input 26	10
Input 27	11
Input 28	12
Input 29	13
Input 30	14
Input 31	15
Input 32	16

## 1.17.1 Specifications

### Module Topology

Inputs per Module	32
Type of Isolation	Optical
Isolation Rating	2500 V RMS
Voltage Operating Range	21-29 VDC
Current Operating Range	10-14 mA
Must Turn On Voltage	16 V
Must Turn On Current	7 mA (at 15 V)
Must Turn Off Voltage	5 V
Must Turn Off Current	2.2 mA (at 25 V)
Input Impedance	2.15K OHMS Resistive
Turn On Time	2.5 ms Nominal
Turn Off Time	2.5 ms Nominal
Rated Current Draw on Sy/Max Power Supply	600 mA at 100% Duty Cycle
LED Operation Indication	Red LED illumination when input module is receiving "ON" signal from field input device.
Ambient Temperature Rating	0-60 C
Humidity Rating	5-95% non-condensing

## 1.18 8030 RIM 361

---

Class 8030 Type RIM-361 16 Function 240 VAC/DC Input Module.

Input 1	—	01
Input 2	—	02
Input 3	—	03
Input 4	—	04
L2	—	1A
Input 5	—	05
Input 6	—	06
Input 7	—	07
Input 8	—	08
L2	—	2A
Input 9	—	09
Input 10	—	10
Input 11	—	11
Input 12	—	12
L2	—	3A
Input 13	—	13
Input 14	—	14
Input 15	—	15
Input 16	—	16
L2	—	4A

### 1.18.1 Specifications

Module Topology

Inputs per Module	16
Type of Isolation	Optical
Isolation Rating	2500 V RMS
Voltage Operating Range	180-264 VAC (50/60Hz) or VDC
Input Current Draw	3.75mA at 180V and 5.5mA at 264V
Must Turn On Voltage	180 V
Must Turn On Current	3.75 mA (at 180 V)
Must Turn Off Voltage	60 V
Must Turn Off Current	1.25 mA (at 60 V)
Input Impedance	48K OHMS Resistive
Turn On Time	8 ms Nominal
Turn Off Time	8 ms Nominal
Rated Current Draw on Sy/Max Power Supply	300 mA at 100% Duty Cycle
Ambient Temperature Rating	0-60 C
Humidity Rating	5-95% non-condensing
Detachable Terminal Block	Class 8030 Type CBP-116

## 1.19 8030 RIM 731

---

Class 8030 Type RIM-731 64 Function, 24 VAC/DC Input Module.

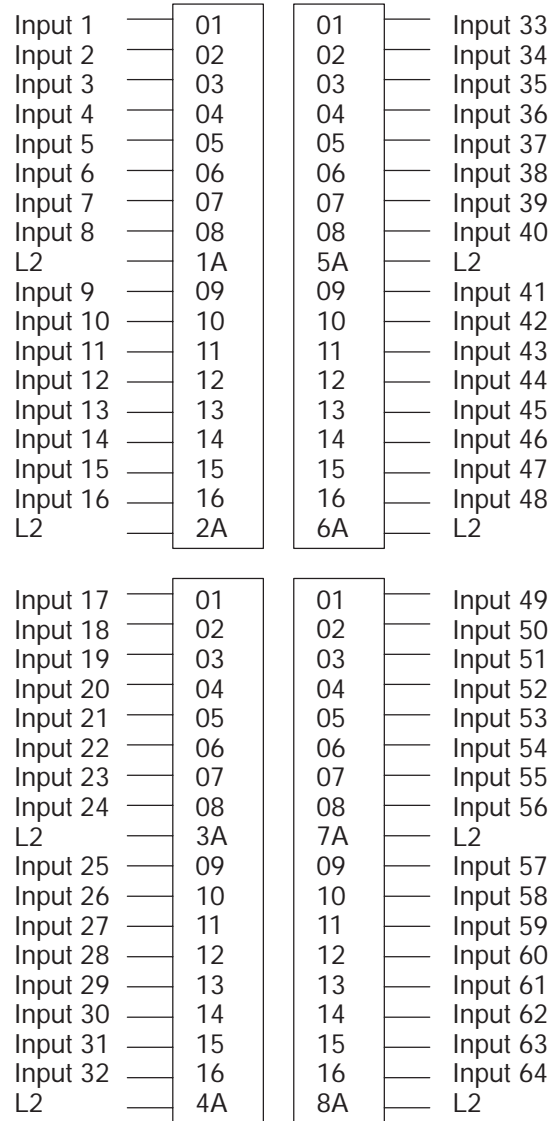

### 1.19.1 Specifications

Module Topology



Inputs per Module	64
Inputs per Common	8
Type of Isolation	Optical
Isolation Rating	1400 VDC
Voltage Operating Range	22-32 VAC (50 or 60 Hz) or VDC
Input Current Draw	1.7 mA at 22V and 2.5 at 32V
Must Turn On Voltage	21.5 VDC, 20 VAC (RMS)
Must Turn On Current	1.5 mA DC, 0.5 mA AC (RMS)
Must Turn Off Voltage	10 VDC, 11 VAC (RMS)
Must Turn Off Current	0.5 mA DC, 0.5 mA AC (RMS)
Input Impedance	12.4K OHMS
Turn On Time	8.3 ms Nominal
Turn Off Time	8.3 ms Nominal
Rated Current Draw on Sy/Max Power Supply	600 mA at 100% Duty Cycle
LED Operation Indication	Red LED illumination when input module is receiving "ON" signal from field input device.
Ambient Temperature Rating	0-60 C
Humidity Rating	5-95% non-condensing

## 1.20 8030 ROM 121

---

Class 8030 Type ROM-121 Analog Output Module.

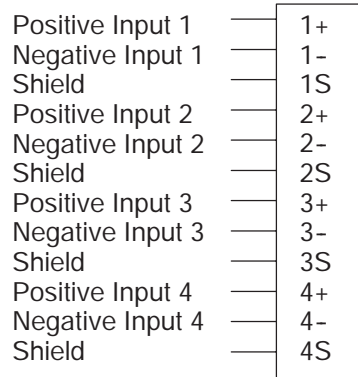

### 1.20.1 Specifications

Module Topology

Outputs per Module	4 (the selected range will apply to all)
Ranges	1-5 VDC, 0-10 VDC, +10 to -10 VDC, 4-20 mA.
Accuracy	Plus or minus 0.15% at 25C, plus or minus 0.5% (of full scale) over 0-60C temperature range. Span and zero require initial user calibration.
Resolution	11-bit, or 1 part in 2048 (full scale range in the storage register of 0-9999). Negative storage register values correspond to the minimum output of the selected range; values in excess of 9999 are represented as the maximum output for the selected range.
Conversion Rate	Output channel reflects register value within 10 msec. of module receiving updated information (40 msec. for all 4 channels).
Isolation	200V channel to ground (or analog output circuit to digital logic circuit) continuously applied. 1500V transient isolation. No analog channel to channel isolation.
Drive Capability	10mA (voltage settings), 600 ohms (current settings)
User Outputs Options upon CPU Halt	HOLD (maintain the last value received while in RUN) or RESET (go to the minimum output for the selected range within 40 msec. of CPU HALT).
Short Circuit Protection	Yes
Power Requirement	1500 mA current draw from Sy/Max power supply connected to the rack.
Run Light	Indicates digital logic circuitry is functioning properly.
Ambient Temperature Rating	0-60 C
Humidity Rating	5-95% relative humidity (non-condensing)
Detachable Terminal Block	Class 8030 Type CBP-110

## 1.20.2 Dip Switch Settings

User Range	S1 to S4	S5	S6	S7	S8
-10 to 10 V	O	X	O	O	
0 to 10 V	O	O	O	O	
1 to 5 V	O	O	X	X	
4 to 20 mA	X	O	O	X	
Hold Output					O
Ramp Output					X
X=ON O=OFF					

## 1.21 8030 ROM 122

---

Class 8030 Type ROM-122 4 Channel Isolated Analog Output Module.

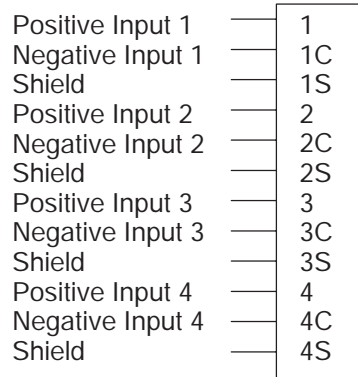

### 1.21.1 Specifications

Module Topology

Outputs per Module	4 (each channel can be individually configured via DIP switches for any one of six output ranges)
Ranges	0-5 VDC, 0-10 VDC, +10 to -10 VDC, +5 to -5 VDC, +2.5 to -2.5 VDC, 4-20 mA.
Accuracy	Plus or minus 0.05% at 25C, plus or minus 0.25% (of full scale) over 0-60C temperature range. Span and zero require initial user calibration.
Resolution	12-bit, or 1 part in 4000 internally scaled to a full scale range in the storage register of 0-9999. Negative storage register values correspond to the minimum output of the selected range. Values in excess of 9999 will be represented as the maximum output for the selected range.
Conversion Rate	2 ms (typical) per channel, less than 5 ms for all four channels.
Isolation	1000V RMS analog channel to channel and channel to ground (analog output circuit to digital logic circuit) continuously applied. 1500V (peak) transient isolation.
Drive Capability	10mA (voltage settings), 600 ohms (current settings)
User Outputs Options upon CPU Halt	HOLD the last value received while in RUN. RESET to the minimum value for the selected range. PRESET the output to a user specified value.
Output Protection	Voltage mode - Short Circuit Protection Current mode - Open Circuit Protection
Power Requirement	1200 mA current draw from Sy/Max power supply connected to the rack.
Run Light	Indicates digital logic circuitry is functioning properly.
Ambient Temperature Rating	0-60 C
Humidity Rating	5-95% relative humidity (non-condensing)

### 1.21.2 Dip Switch Settings

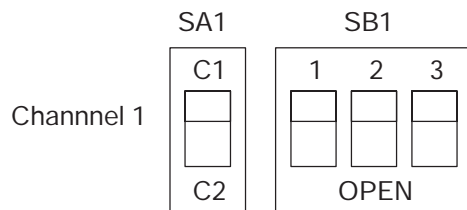

SAx	SBx-1	SBx-2	SBx-3	Output Range
C1	1	0	0	+/-10V
C1	1	0	1	+/-5V
C1	1	1	1	+/-2.5V
C1	0	1	1	0-5VDC
C1	0	0	1	0-10VDC
C2	0	0	1	4-20mA

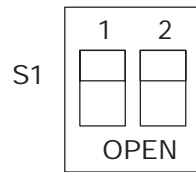
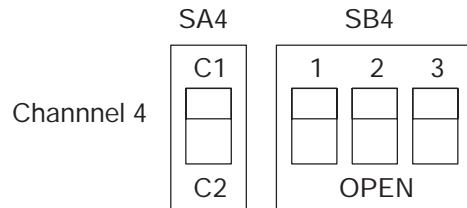
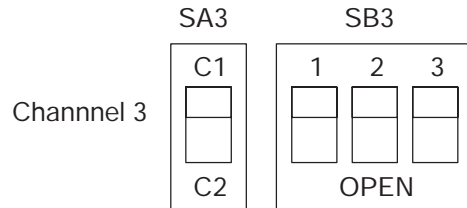
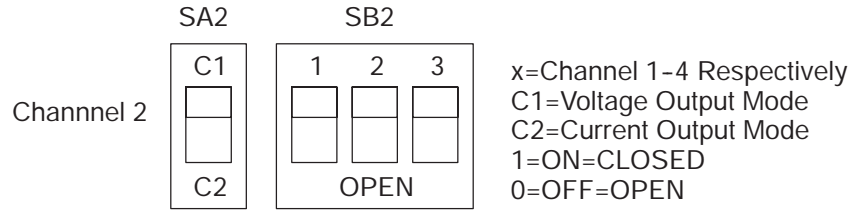

S1-1

1=Reset the outputs (go to the minimum value for the selected range)

0=Selected from the output options available on dipswitch S1-2

S1-2

1=Set the outputs to the values contained in the preset registers.

0=Hold the outputs (maintain the last value received while in run).

## 1.22 8030 ROM 131

---

Class 8030 Type ROM-131 Stepping Motor Controller Module.

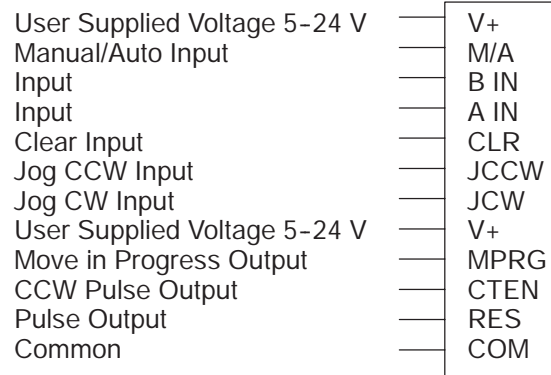

### 1.22.1 Specifications

Module Topology



Register Addresses Used	16 maximum
Register Slots Required	1
Max. Cable Distance Between Module and Stepping Motor Translator	100 ft./30m at no more than 30pf. (cable capacitance) per foot.
Move Length	0 to 99,999,999 pulses
Move Rate (Slew Rate)	0 to 9,999 pules per sec.
Pulse Rate Accuracy During Move	+/- 5% of value
Pulse Rate Accuracy During Acceleration	+/- 20% of theoretical rate
Pulse Rate Accuracy During Deceleration	+/- 20% of theoretical rate
Acceleration and Deceleration Time	0 or within the range 50 to 2000 msec
Time to Calculate Move from Move Table	5 msec. (max.), 200 msec. typical.
Time to Calculate Move from Ladder Diagram	100 msec. (max.)
Output Pulse Width Accuracy	+/- 20% of selected (SW1) rate (20 usec. or 5 usec.)
Output Pulse Rise and Fall Times	1 usec. or less when driving a 0.003 ufd load at TTL output levels measured from 10% to 90% levels.
User Inputs	(6) Manual/Auto, Jog (CW,CCW), Clear, Input A, Input B
Input Voltage Range	5-24 VDC
Max Input Current	16 mA per Input
Input Isolation	Yes (optical)
User Outputs	(3) CW pulses, CCW pulses, Move in Progress.
Output Voltage Range	5-24 VDC
Output Current Range	100 mA - Sinking (5-24 VDC)



Note Outputs can source 400 uA at TTL levels and meet standard TTLsaturation levels when switching 5 volts.

Output Isolation	Yes (optical)
Rated Current Draw on Sy/Max Power Supply	1500 mA max.
Ambient Temperature Rating	0-60 C
Humidity Rating	5-95% non-condensing



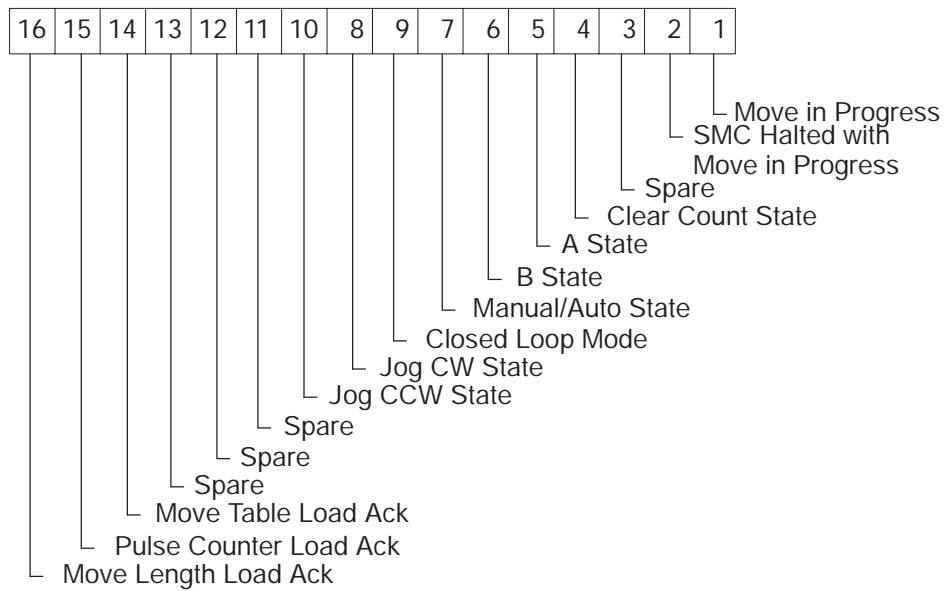

Register 3: SMC Move Table Control Register (R/W)

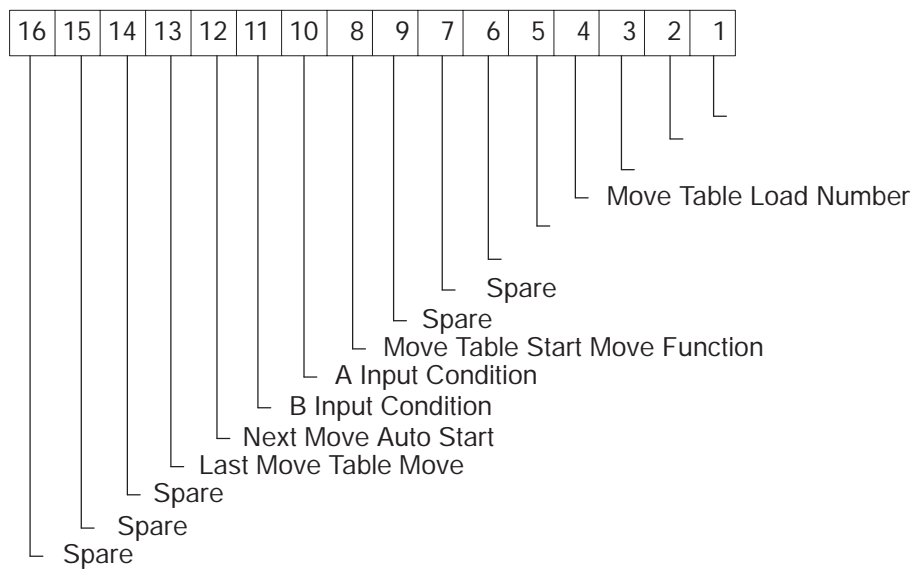

Register 4: Move Length Least Significant Register (R/W)

Register 5: Move Length Most Significant Register (R/W)

Register 6: Preset Accumulated Pulse Counter Least Significant Register (R/W)

Register 7: Preset Accumulated Pulse Counter Most Significant Register (R/W)

Register 8: PC/SMC Move Control Bit Register (R/W)

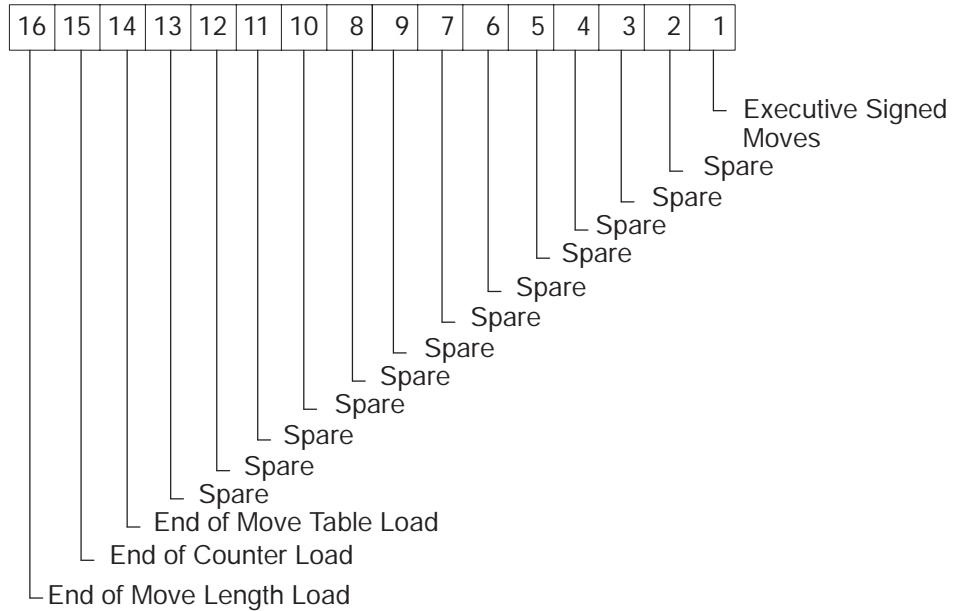

Register 9: EFSS Rate (R/W)

Register 10: Move Rate or Slew Rate (R/W)

Register 11: Acceleration Time (R/W)

Register 12: Deceleration Time (R/W)

Register 13: Accumulated Pulse Counter, Least Significant Register (R)

Register 14: Accumulated Pulse Counter, Most Significant Register (R)

Register 15: Error and Current Move Status Register (R)

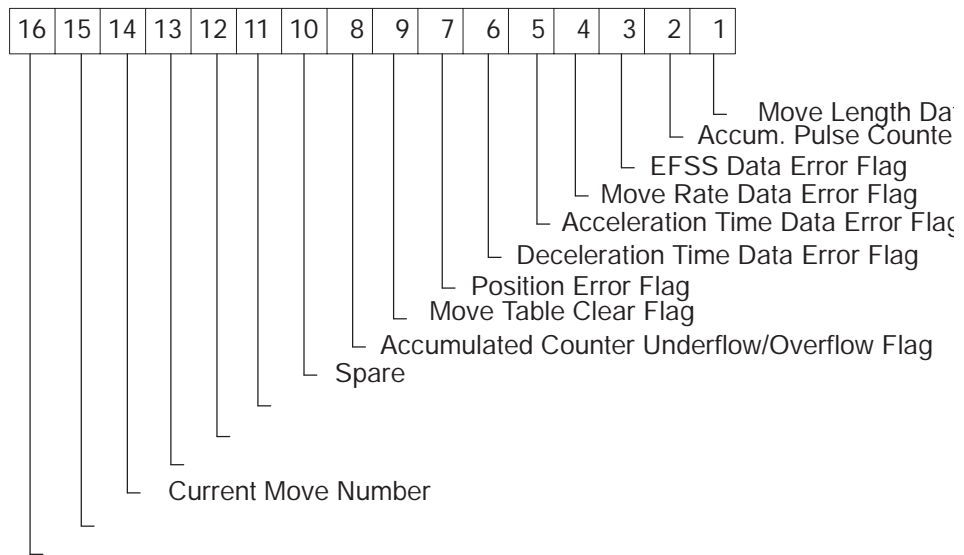

Register 16: Spare

## 1.23 8030 ROM 141

---

Class 8030 Type ROM-141 Multiplexed BCD Output Module.

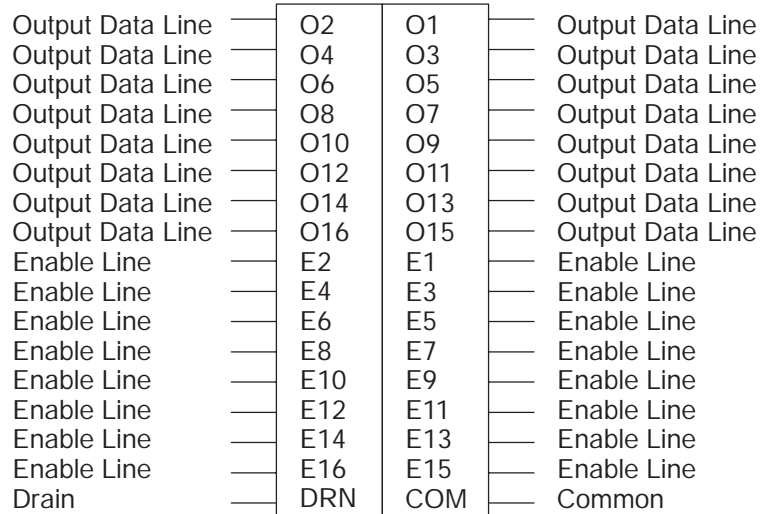

### 1.23.1 Specifications

Module Topology Multiplexed Mode

Register Addresses Used	16 Maximum
Register Slots Required	1
Max Number of Displays per Module	16 four digit sets (64 displays)
Type of BCD Devices Allowed	4 digit max (0-9999) with on-board data latch and BCD decoding capability
Field Wiring Connector capacity	8, 24 AWG wires per terminal
Max Cable Distance Between Module and BCD Device	200ft/60m
Operating Voltage Range	TTL level DATA and ENABLE lines
DATA LINE Logic	True high (sourcing)
ENABLE LINE Logic	True Low (sinking) Data will be transferred (latched) when the ENABLE LINE (E1-E16) is a low TTL level. A one (High TTL) allows data to change.
Logic Levels	LOGIC 1: Source 5.2mA at 2.4VDC min LOGIC 0: Sink 48mA at 0.5VDC max
Short Circuit Protection	Yes, between Data and Enable lines and ground.
User Power Supply Requirements	Yes, for LED displays. The user power supply current requirements are dependent on the type and number of LED displays. No external power supply is needed for the BCD Output Module.
BCD Latch/Enable Frequency	Switch Selectable (S1) 1Hz or 10Hz
LED Operation Indication	Red ERROR LED illuminates when a BCD Output Module malfunction occurs.
Rated Current Draw on Sy/Max Power Supply	900 mA max.
Ambient Temperature Rating	0-60 C
Humidity Rating	5-95% non-condensing

### 1.23.2 Dip Switch Settings

Function	SW1-1	SW1-2
Self-Test Mode	ON	ON
10Hz Strobe Rate	ON	OFF
1 Hz Strobe Rate	OFF	OFF
Do NOT Set This Position. Rack Shutdown will occur	OFF	ON

## 1.24 8030 ROM 221/431

---

For the Specification on the 431 module click [HERE](#).

Class 8030 Type ROM-221 16 Function 120 VAC Output Module.

Output 1	—	01
Output 2	—	02
Output 3	—	03
Output 4	—	04
L1	—	1A
Output 5	—	05
Output 6	—	06
Output 7	—	07
Output 8	—	08
L1	—	2A
Output 9	—	09
Output 10	—	10
Output 11	—	11
Output 12	—	12
L1	—	3A
Output 13	—	13
Output 14	—	14
Output 15	—	15
Output 16	—	16
L1	—	4A

### 1.24.1 Specifications

Module Topology



Outputs per Module	16
Type of Isolation	Optical
Isolation Rating	2500 V RMS
Voltage Operating Range	20-138 VAC (50/60Hz)
Turn On Time	8 ms Nominal
Turn Off Time	8 ms Nominal
Fuse	Four, 5A Buss MTH
Output LED operation	Red LED illuminated when receiving "ON" signal from processor.
Fuse LED operation	Red LED illuminated when a blown fuse is detected (one for each group of four outputs)
Maximum Continuous Current	2 Amps per output, 4 Amps per 4 outputs, 16 Amps per module.
Maximum Inrush Current	25 Amps for 3 cycles at 50/60 Hz, no more than once every 10 sec.
Minimum Load Current	6 mA
Max On State Voltage Drop Across Output	2.0V at 2 Amp Load
Max Off State Leakage Current	2.0 mA at 138V, 50/60 Hz
Rated Current Draw on Sy/Max Power Supply	950 mA at 100% Duty Cycle
Ambient Temperature Rating	0-60 C
Humidity Rating	5-95% non-condensing
Detachable Terminal Block	Class 8030 Type CBP-116

## 1.25 8030 ROM 271

---

Class 8030 Type ROM-271 16 Function Isolated Relay Output Module.

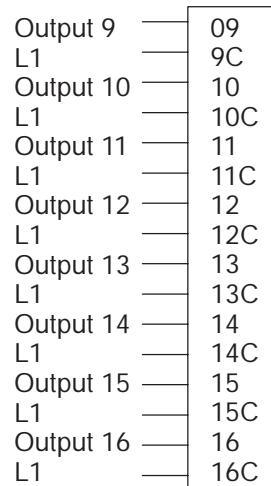
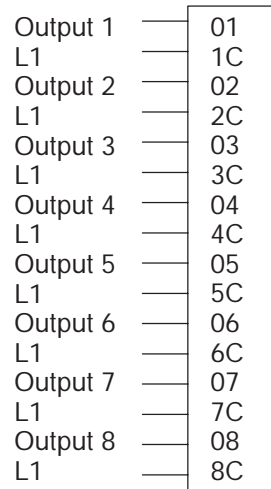

### 1.25.1 Specifications

Module Topology

Outputs per Module	16
Outputs per Common	1
Type of Isolation	Relay
Isolation Rating	2500 V RMS
Turn On Time	10 ms Nominal
Turn Off Time	10 ms Nominal
Fuse	16, 2.5A. Buss AGC-2 1/2
Output LED operation	Red LED illuminated when receiving "ON" signal from processor.
Maximum output voltage	240 VAC, 120 VDC
Maximum output current per point	2A, AC/DC
Maximum pilot duty rating per point	AC: 2A at 5-125 VAC 1A at 126-240 VAC DC: 2A at 5-30 VDC 0.4A at 31-60 VDC 0.1A at 61-120 VDC
Minimum permissible load per point	5 VDC, 10 mA
Rated Current Draw on Sy/Max Power Supply	900 mA at 100% Duty Cycle
Ambient Temperature Rating	0-60 C
Humidity Rating	5-95% non-condensing
Detachable Terminal Block	Square D part number: 30617-002-50

## 1.26 8030 ROM 421

---

Class 8030 Type ROM-421 16 Function 35-140 VAC Output Module.

Please contact Technical Support for this information.

## 1.27 8030 ROM 431

---

Class 8030 Type ROM-431 16 Function 220/240 VAC Output Module.

Output 1	—	01
Output 2	—	02
Output 3	—	03
Output 4	—	04
L1	—	1A
Output 5	—	05
Output 6	—	06
Output 7	—	07
Output 8	—	08
L1	—	2A
Output 9	—	09
Output 10	—	10
Output 11	—	11
Output 12	—	12
L1	—	3A
Output 13	—	13
Output 14	—	14
Output 15	—	15
Output 16	—	16
L1	—	4A

### 1.27.1 Specifications

Module Topology

Outputs per Module	16
Type of Isolation	Optical
Isolation Rating	2500 V RMS
Voltage Operating Range	20-264 VAC (50/60Hz)
Turn On Time	8 ms Nominal
Turn Off Time	8 ms Nominal
Fuse	Four, 5A Buss MTH
Output LED operation	Red LED illuminated when receiving "ON" signal from processor.
Fuse LED operation	Red LED illuminated when a blown fuse is detected (one for each group of four outputs)
Maximum Current	2 Amps per output, 4 Amps per 4 outputs, 16 Amps per module.
Maximum Inrush Current	25 Amps for 3 cycles at 50/60 Hz, no more than once every 10 sec.
Minimum Load Current	6 mA (resistive load) 24 mA (other type load)
Max On State Voltage Drop Across Output	2.0V at 2 Amp Load
Max Off State Leakage Current	5 mA at 250 VAC, 50 Hz 24 mA at 250 VAC, 60 Hz
Rated Current Draw on Sy/Max Power Supply	950 mA at 100% Duty Cycle
Ambient Temperature Rating	0-60 C
Humidity Rating	5-95% non-condensing
Detachable Terminal Block	Class 8030 Type CBP-116

## 1.28 8030 ROM 441

---

Class 8030 Type ROM-441 24V VDC 32 Function Output Module

Positive	—	VDC+
Negative	—	VDC-
Output 1	—	01
Output 2	—	02
Output 3	—	03
Output 4	—	04
Output 5	—	05
Output 6	—	06
Output 7	—	07
Output 8	—	08
Output 9	—	09
Output 10	—	10
Output 11	—	11
Output 12	—	12
Output 13	—	13
Output 14	—	14
Output 15	—	15
Output 16	—	16

Positive	—	VDC+
Negative	—	VDC-
Output 17	—	01
Output 18	—	02
Output 19	—	03
Output 20	—	04
Output 21	—	05
Output 22	—	06
Output 23	—	07
Output 24	—	08
Output 25	—	09
Output 26	—	10
Output 27	—	11
Output 28	—	12
Output 29	—	13
Output 30	—	14
Output 31	—	15
Output 32	—	16

## 1.28.1 Specifications

### Module Topology

Outputs per Module	32
Type of Isolation	Optical
Isolation Rating	2500 V RMS
Voltage Operating Range	21-29 VDC
Turn On Time	100 usec. max. at 24V
Turn Off Time	100 usec. max. with 0.5A inductive load
Output LED operation	Red LED illuminated when receiving "ON" signal from processor.
Maximum Current	0.5 Amps per output, 12 Amps per module
Minimum Load Current	See application considerations in Instruction Bulletin 30598-285-01
Max On State Voltage Drop Across Output	1.5 VDC
Max Off State Leakage Current	0.1 mA Max.
Max Surge Current	3 Amp for 300 usec. Duty Cycle Less than or Equal to 2%
Rated Current Draw on Sy/Max Power Supply	980 mA at 100% Duty Cycle
Ambient Temperature Rating	0-60 C
Humidity Rating	5-95% non-condensing



## 1.29 8030 ROM 871

---

Class 8030 Type ROM-871 64 Function Reed Relay (Form A) Output Module.

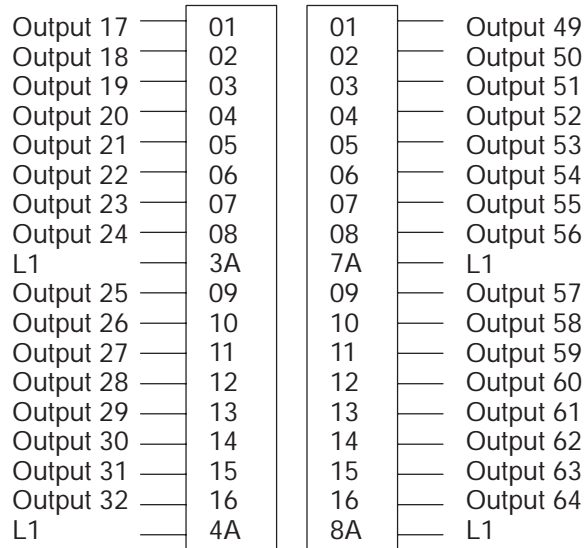
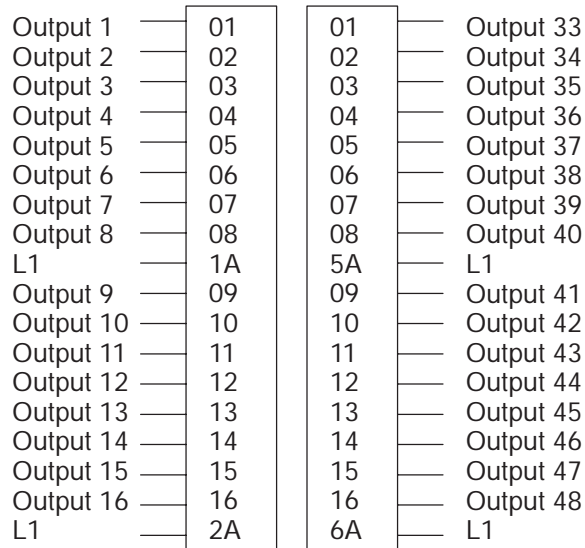

### 1.29.1 Specifications

Module Topology

SY/MAX Remote I/O 73

Outputs per Module	64
Outputs per Common	8
Type of Isolation	Relay
Isolation Rating	1400 V RMS
Turn On Time	1.5 ms Nominal
Turn Off Time	1.5 ms Nominal
Fuse	Wickman 19374K, TR5-T
Output LED operation	Red LED illuminated when receiving "ON" signal from processor.
Voltage Range (see note)	5 to 30 VAC/VDC
Maximum Current (see note)	400 mA/output 2.5 A/common
Maximum Surge Current	0.5 A
Maximum Power Rating (switching)	8 VA (AC) 8 Watt DC
Initial Relay Contact Resistance	150 milliohms
Relay Contact Life	200 X 10,000,000 operations
Max. Reed Relay Operating Frequency	100 Hz
Rated Current Draw on Sy/Max Power Supply	1250 mA at 100% Duty Cycle
Ambient Temperature Rating	0-60 C
Humidity Rating	5-95% non-condensing



Note Observe the maximum power rating for all voltage and current combinations; i.e. 0.3 A at 24V AC/DC

## 1.30 8030 SIM 116

---

16 Input SIM Module.

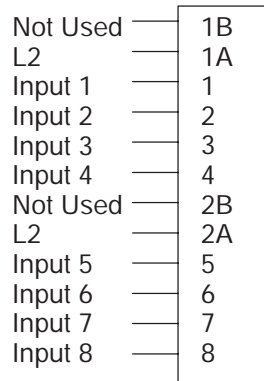

### 1.30.1 Specifications

Module Topology

Inputs per Module	8
Type of Isolation	Optical
Isolation Rating	2500 V RMS
Voltage Operating Range	90-132 VAC (50/60Hz) or VDC
Input Current Draw	7-11 mA
Must Turn On Voltage	90 V
Must Turn On Current	7 mA (at 90 V)
Must Turn Off Voltage	40 V
Must Turn Off Current	3 mA (at 40 V)
Input Impedance	12 k Ohms Resistive
Turn On Time	8 ms Nominal
Turn Off Time	8 ms Nominal
Rated Current Draw on Sy/Max Power Supply	70 mA at 100% Duty Cycle
Ambient Temperature Rating	0-60 C
Humidity Rating	0-95% non-condensing
Detachable Terminal Block	Class 8030 Type CBP-110

